



# General Chemistry (I)

For 1<sup>st</sup> year University Students.

Prepared by:

**Dr. Ibrahim A. I. Hassan**

Department of Chemistry, Faculty of Science, South  
Valley University, 83523 Qena, Egypt.

Email: [I.Hassan@bath.edu](mailto:I.Hassan@bath.edu)

## COPYRIGHT

Attention is drawn to the fact that copyright of this book rests with its author. A copy of this book has been supplied on condition that anyone who consults it is understood to recognize that its copyright rests with the author and they must not copy it or use material from it except as permitted by law or with the consent of the author.

**Dr. Ibrahim A. I. Hassan**

..... *I. Hassan* .....

# **First Level (Freshman) - Course's Contents of Physical Science and Geological Science Programs.**

**Chm 101: General Chemistry (I) - 3 Credits (Lecture 2 Hrs. / W  
+ Lab. 2 Hrs. / W).**

## **Contents:**

The history of atomic theory-Different Atomic models - Thomson Model of Atom - Bohr Model of the Atom - Rutherford's Nuclear Model of Atom - Electron Discovered- Protons & Nucleus Discovered - Electron's Charge Measured- Quantum Model of the Atom - Quantum number - Modern Atomic Theory - Schrodinger's atomic Model (THE Cloud Model) - de Broglie (Dual Behavior of Matter) - Heisenberg's Uncertainty Principle - Quantum Mechanical model of atom (Schrodinger's equation) - Shapes of Atomic Orbitals - Filling of orbitals in Atom - Aufbau Principle – Hond's rules - Periodic table - Periodic table properties - ionization energy - electronegative force - electron affinity -oxidation and reduction state - types of bonds - hybridization.

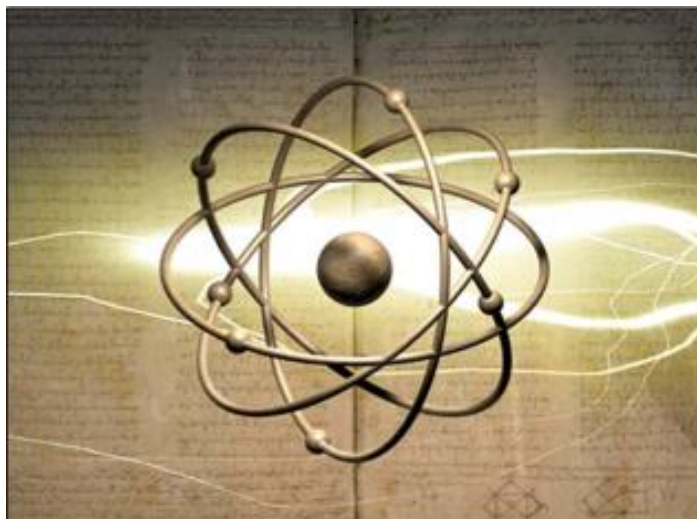

# **First Level (Freshman) - Course's Contents of Physical Science and Geographical Science Programs.**

**Chm 101: General Chemistry (I) - 3 Credits (Lecture 2 Hrs. / W + Lab. 2 Hrs. / W).**

## **Contents:**

**The history of atomic theory - Different Atomic models - Thomson Model of Atom - Bohr Model of the Atom - Rutherford's Nuclear Model of Atom - Electron Discovering - Protons & Nucleus Discovering - Electron's Charge Measuring - Quantum Model of the Atom - Quantum number - Modern Atomic Theory - Schrodinger's Atomic Model (The Cloude Model) - de Broglie (Dual Behaviour of Matter) - Heisenberg's Uncertainty Principle - Quantum Mechanical model of atom (Schrodinger's equation) - Shapes of Atomic Orbitals - Filling of Orbitals in Atom - Aufbau Principle - Hond rules - Periodic table - Periodic table properties - ionization energy - electronegative force - electron affinity - oxidation and reduction state - types of bonds - hyberdization.**

# Atoms, Molecules, and Chemistry

What are atoms?

1. Atoms are the fundamental units of matter.
2. They are composed of smaller parts:
  - a. Nucleus
    - i. Protons (positively charged)
    - ii. Neutrons (have no charge)
  - b. Electrons

The different components of atoms determine the type and “behavior” of the elements...

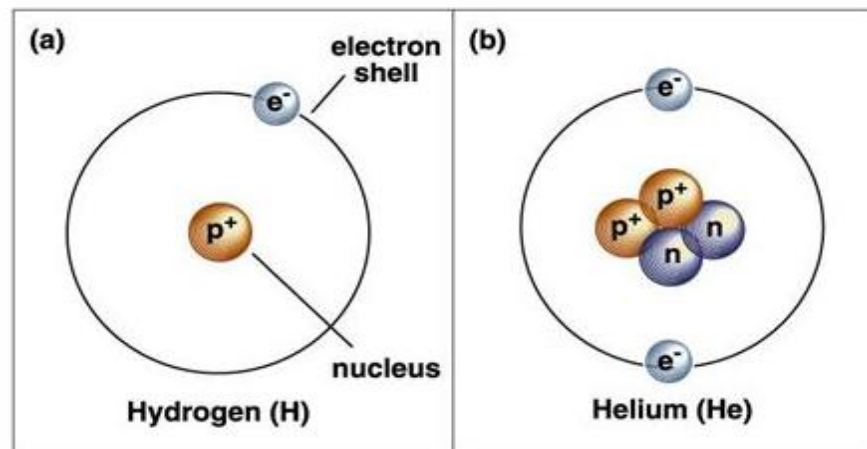



# The History of Atomic Structure



# Democritus (460 - 370 BC)

- Was the first person to come up with the idea of atom
- Believed that all matter was composed of indivisible particles he called "**ATOMS**"
- He also believed that different atoms:
  - Are different sizes
  - Have different properties

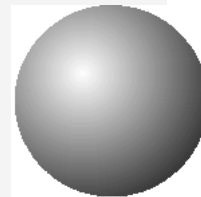

Democritus  
(400 B.C.)

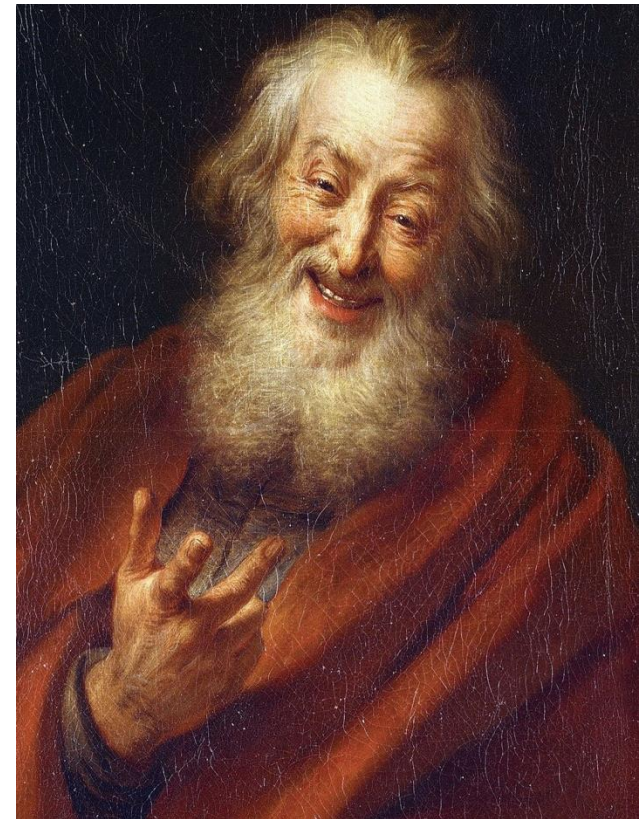

Democritus (460 - 370 BC)

# John Dalton (1766-1844)

- Dalton is the “Father of Atomic Theory”
- Dalton’s ideas were so brilliant that they have remained essentially intact up to the present time and has only been slightly corrected.

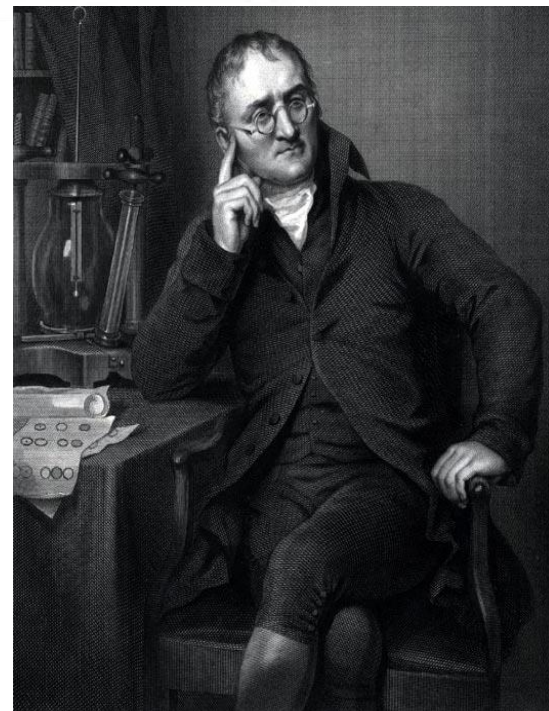

John Dalton (1766-1844)

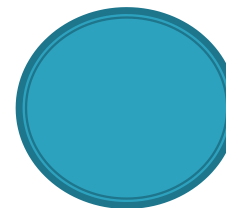

Dalton's Atom

# Dalton's Atomic Theory (1803)

1. All matter is composed of extremely small particles called atoms.
2. All atoms of a given element are identical, having the same:
  - size
  - mass
  - chemical properties
3. All atoms of different elements are different. (a Sodium atom is different than chlorine)

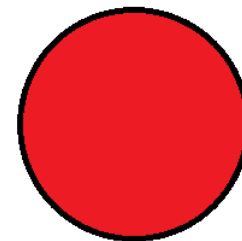

Dalton's "Billiard Ball" Model of Atom

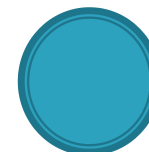

Dalton's Atom



# Dalton's Atomic Theory (1803)

## 4. Atoms cannot be created, divided into smaller particles, or destroyed.

In a chemical reaction, atoms of different elements are separated, joined or rearranged. They are never changed into the atoms of another element.

## 5. Law of Definite Proportions: Different atoms combine in simple whole number ratios to form compounds (you can't have a $\frac{1}{2}$ of a Carbon bonding with Oxygen; it's a whole atom or no atom)



Dalton's Atom

# Dalton's Atomic Theory

Solid Sphere

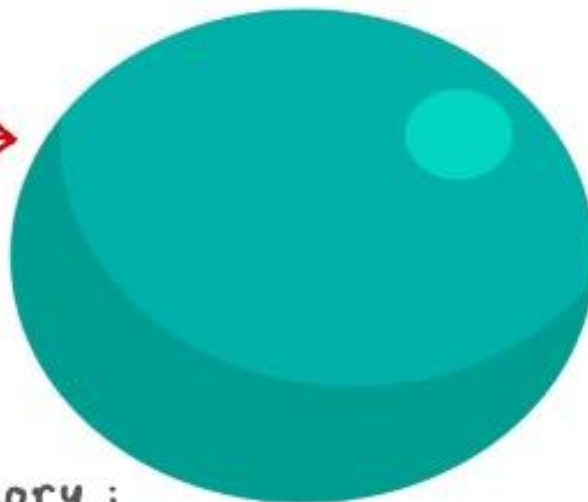

He proposed his theory :

- Atoms are small, **indivisible**
- Can't be divided, created, destroyed
- An element = **identical**
- Different elements = different properties
- Atoms of different elements combine to form **compounds**



**John Dalton**

# Dalton's Atomic Theory



## Dalton's Atomic Theory

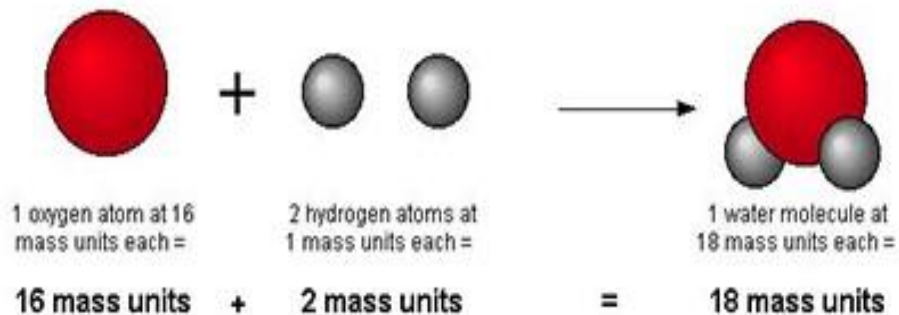

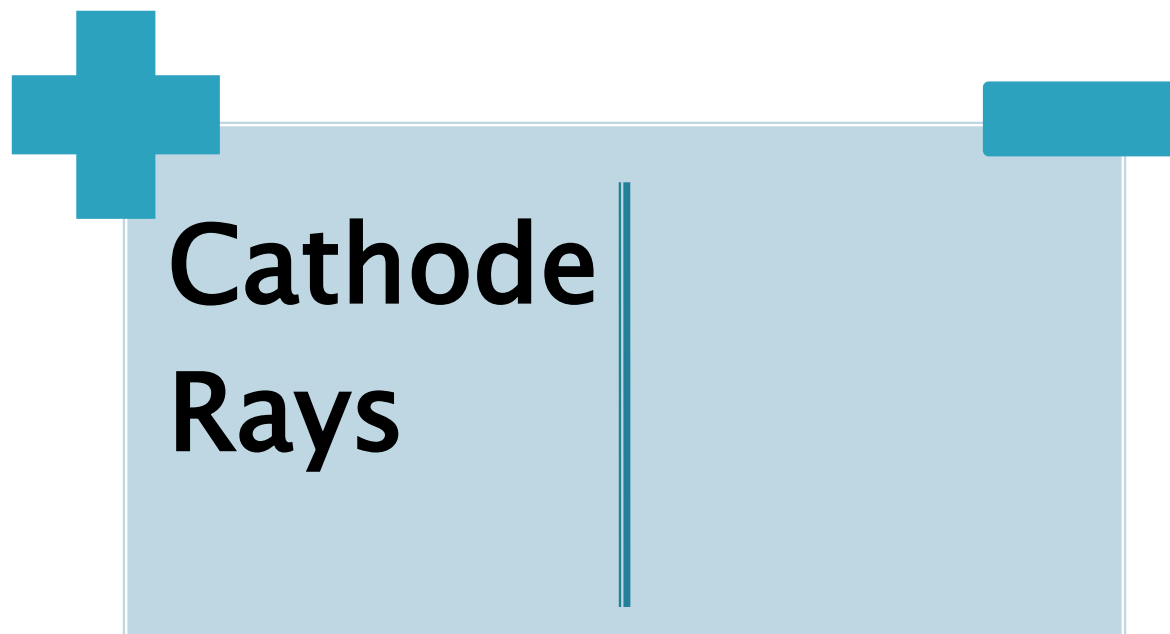

# **Cathode Rays (Discovering of Electrons) (Plücker 1858 and Thomson 1897)**

## **Cathode Rays experiments**

**These experiments relied on the following basis:**

- 1. All Gases under the normal conditions of pressure and temperature are insulator for electricity.**
- 2. If a closed tube was evacuated of gases until the pressure becomes less than 0.01 to 0.001 mmHg, at these conditions the gas becomes conductor at a specific potential.**



# Cathode Rays (Discovering of Electrons) (Plücker 1858 and Thomson 1897)

## Cathode Rays' experiments

3. If the potential between the two electrodes increase up to 10 KV, it can be noticed a current of rays from Cathode to Anode, causing flashing of light on the walls of the evacuated tube, these rays called Cathode rays, or Electrons.

Julius Plücker (16 June  
1801 – 22 May 1868)

was a pioneer in the investigations of cathode rays (1858) that led eventually to the discovery of the electron (1897).

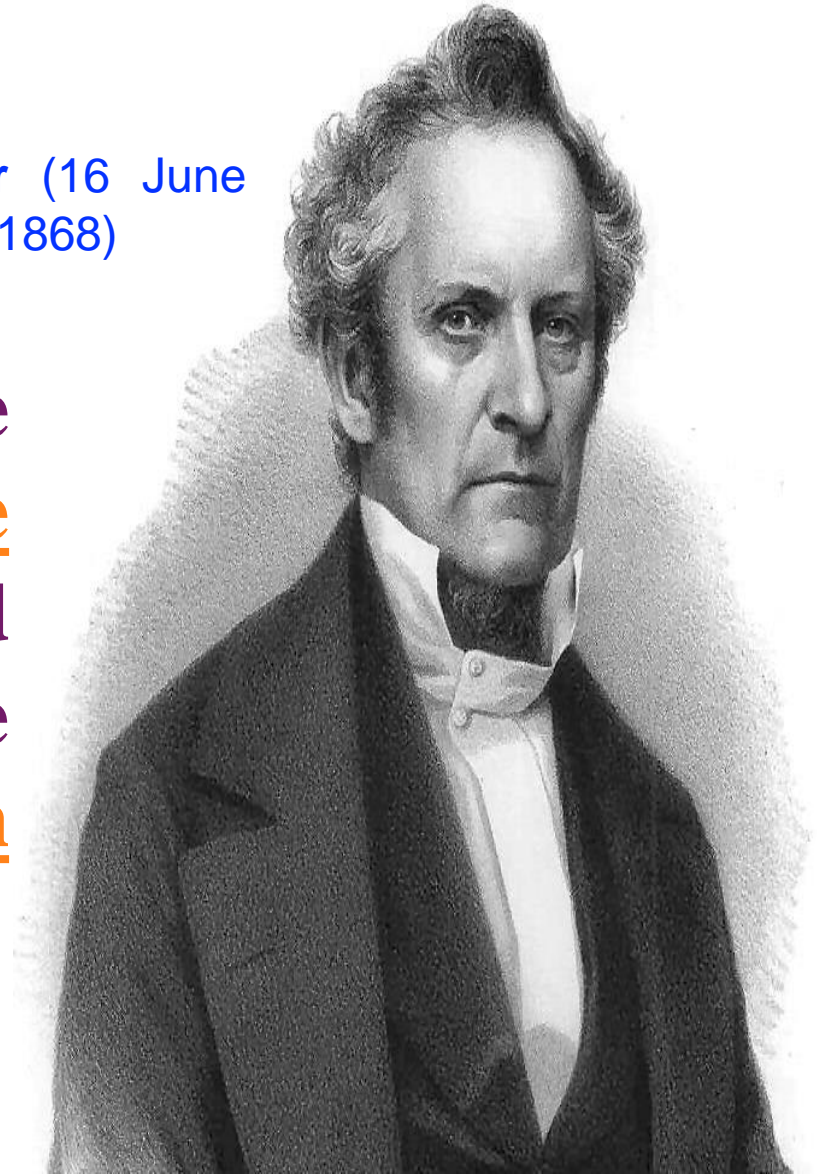

# Joseph John Thomson

<b>Born</b>	<b>18 December 1856</b> <u>Cheetham Hill, Manchester,</u> <b>England</b>
<b>Died</b>	<b>30 August 1940 (aged 83)</b> <u>Cambridge, England</u>



**J. J. Thomson**

Cathode Rays' experiments

Discharge Tube

Air at very low pressure

Green glow

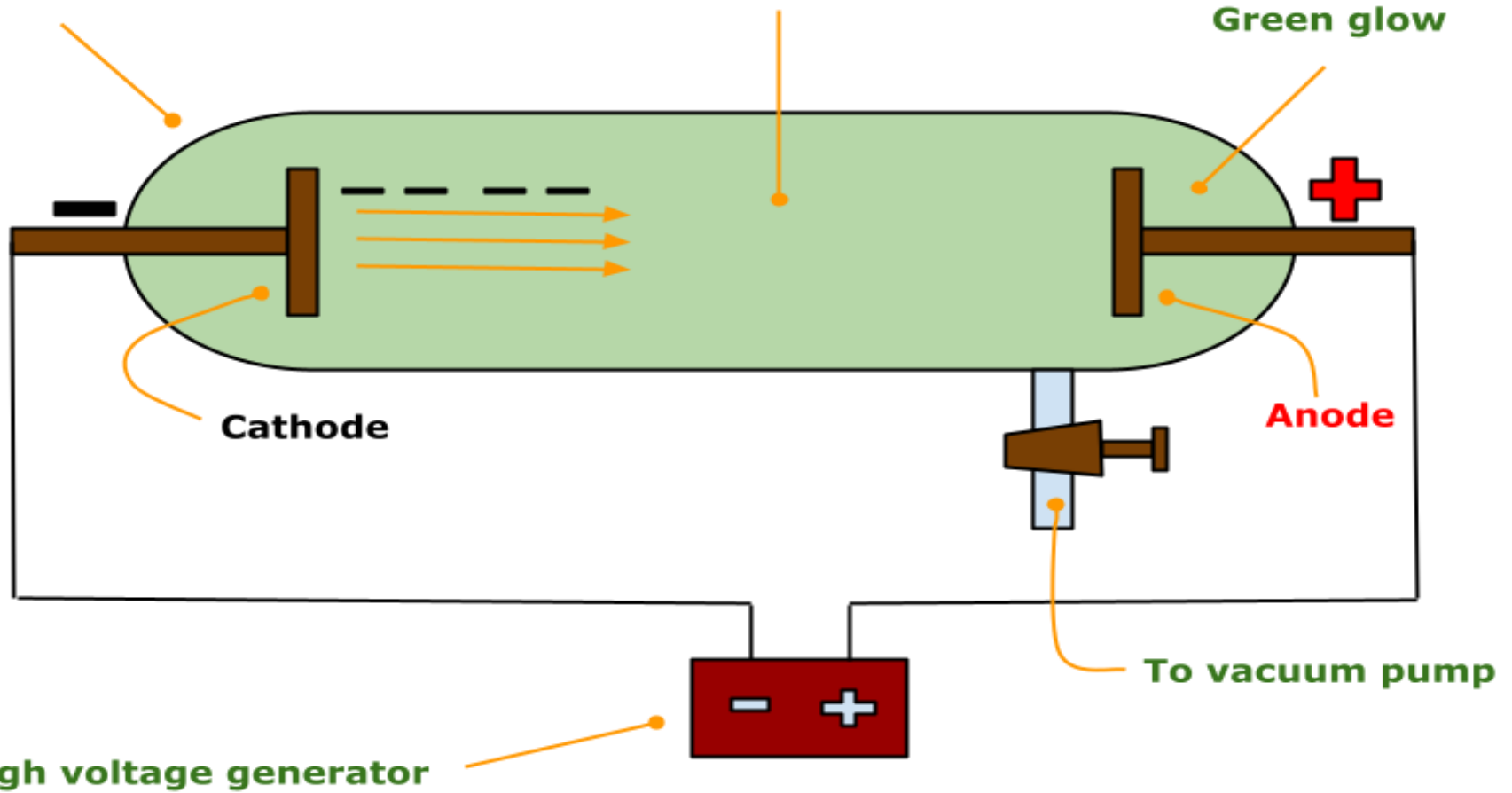

Cathode

Anode

To vacuum pump

High voltage generator

Production of cathode rays

Cathode Rays' experiments

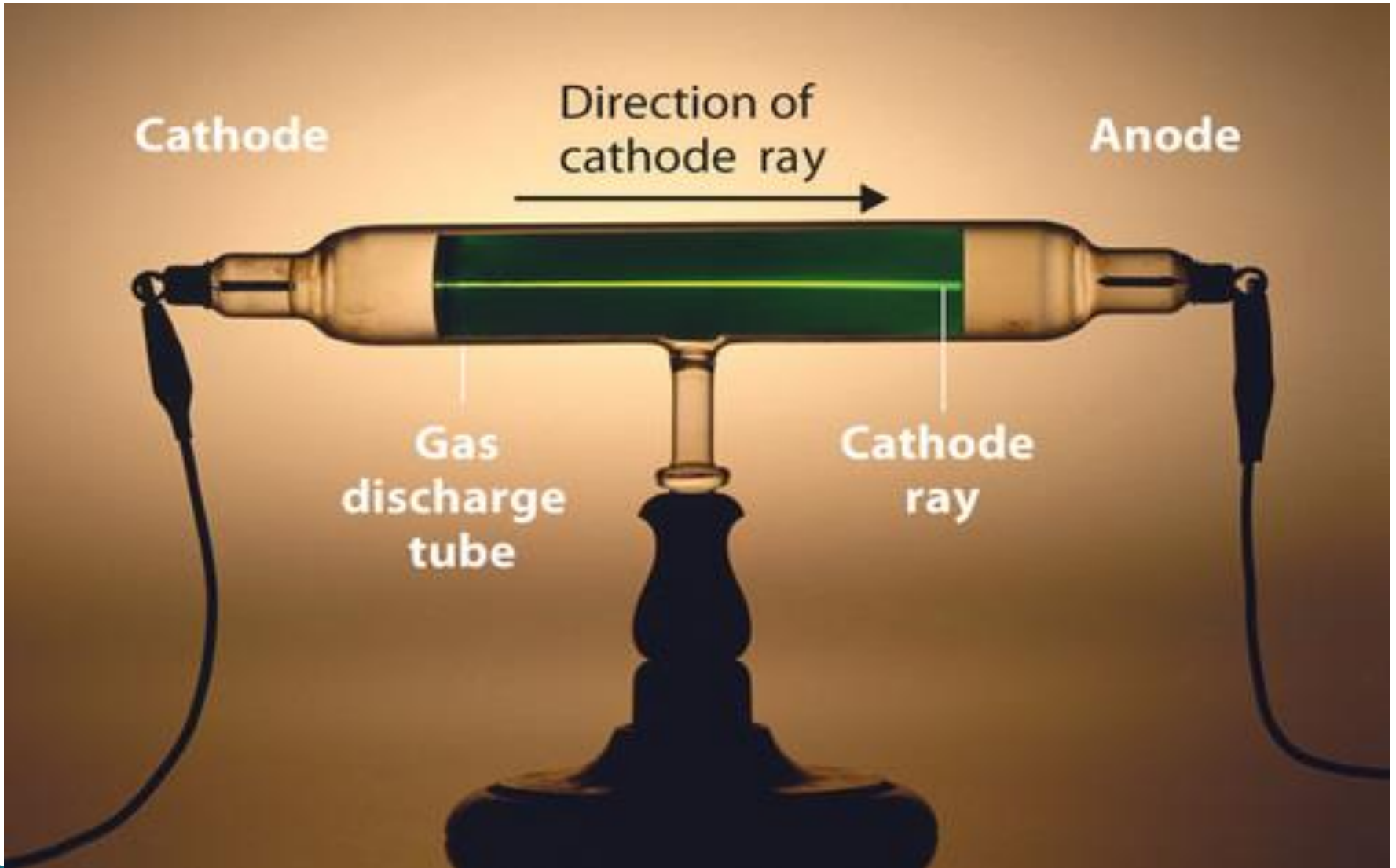



Cathode Rays' experiments

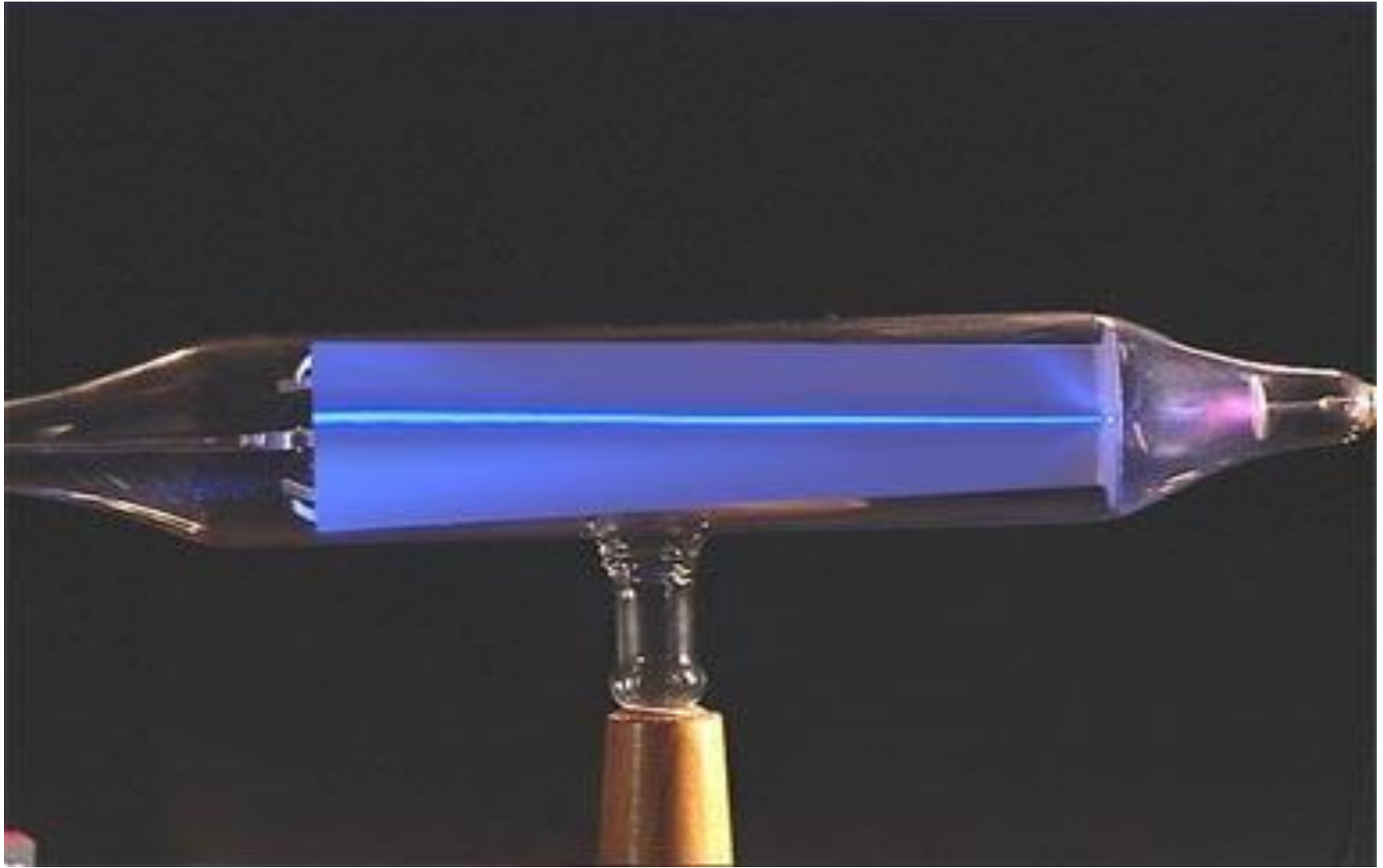

# Characters of Cathode Rays

## Characters of Cathode Rays

Cathode rays are current of unseen rays produced from cathode causing flashing light on evacuated tube's walls.

1. Consists of very small particles called electrons.
2. Move in straight lines.
3. Have a heat effect.
4. Affected by both of electric and magnetic fields.
5. Have a negative charge.
6. Don't change according to material types or gas type, which means that they are contained in all substances.

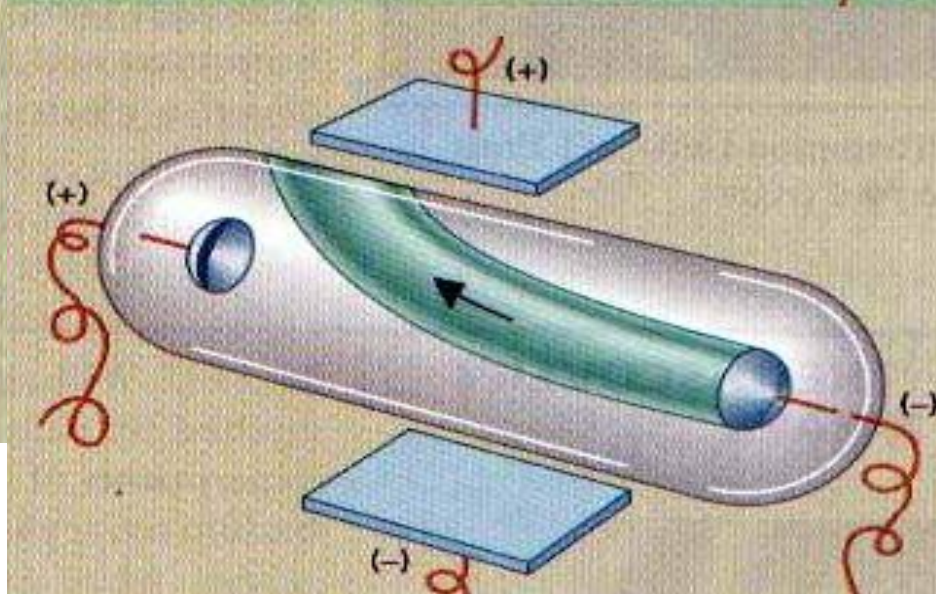
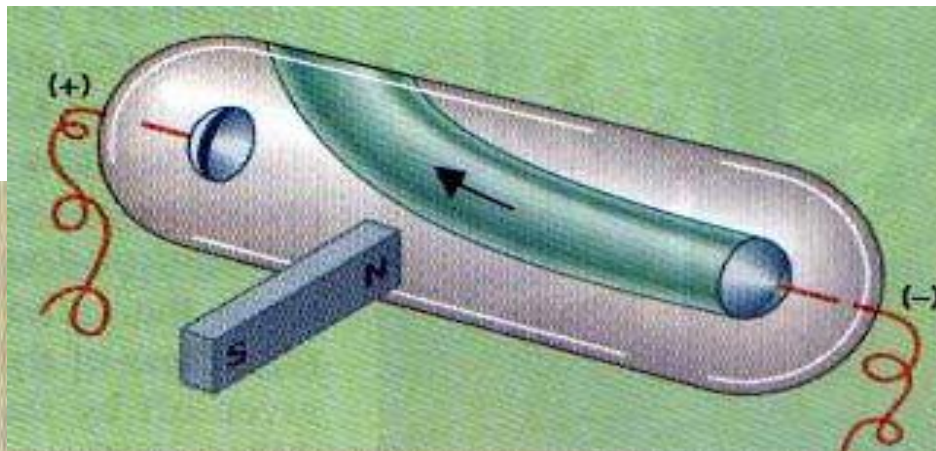
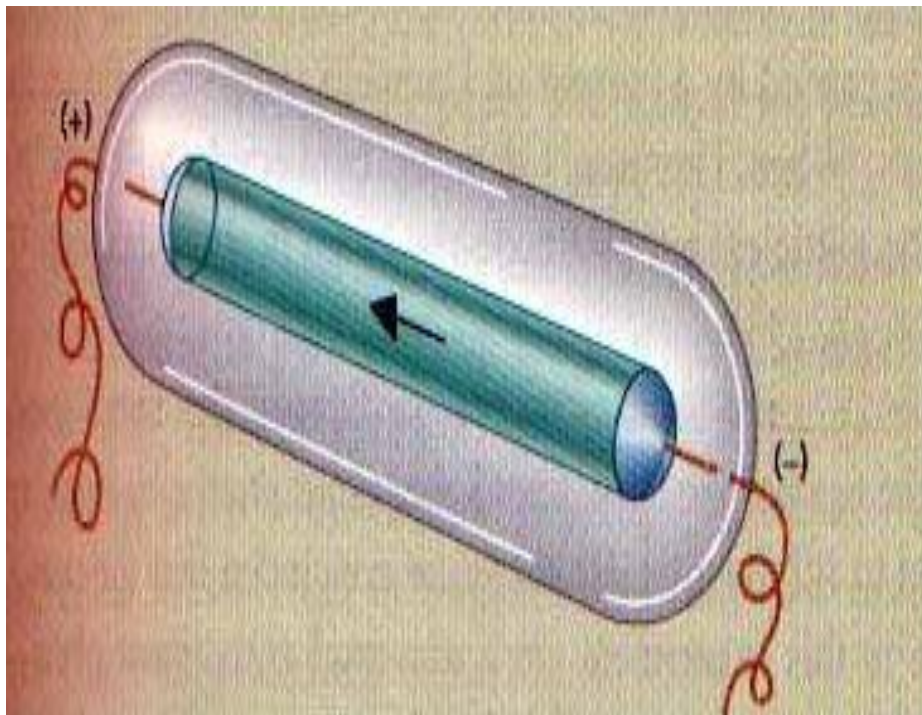



Cathode Rays' experiments

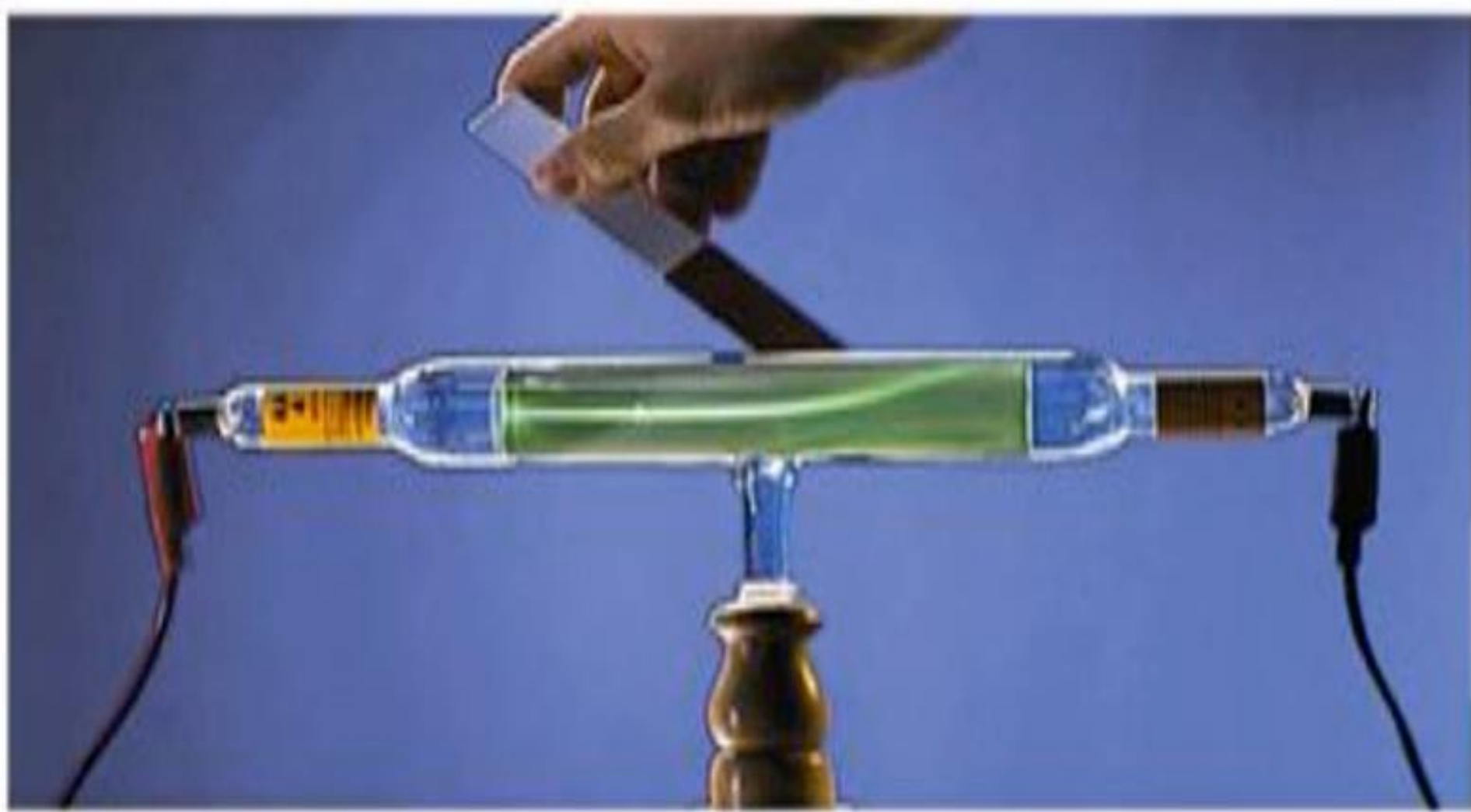



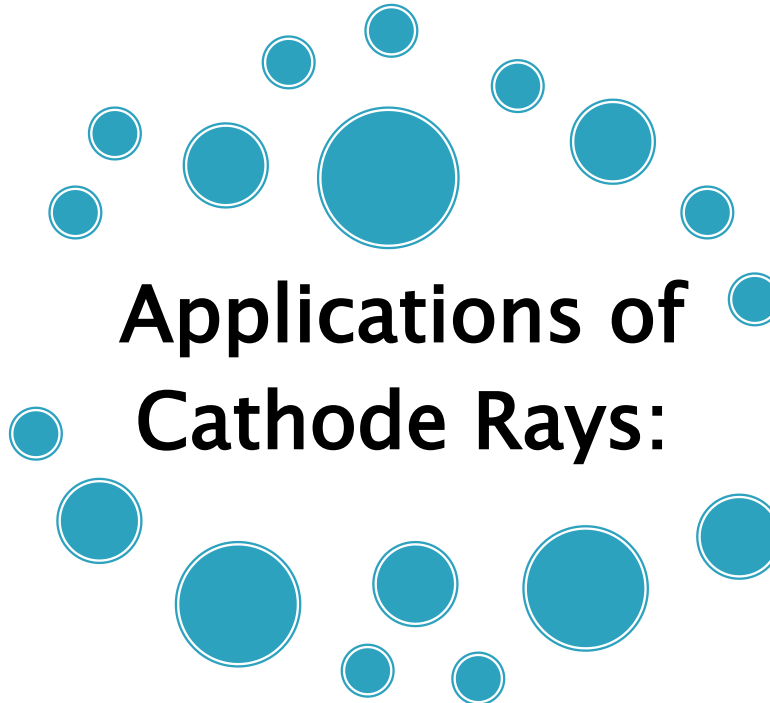

# Applications of Cathode Rays:

Cathode Rays' experiments

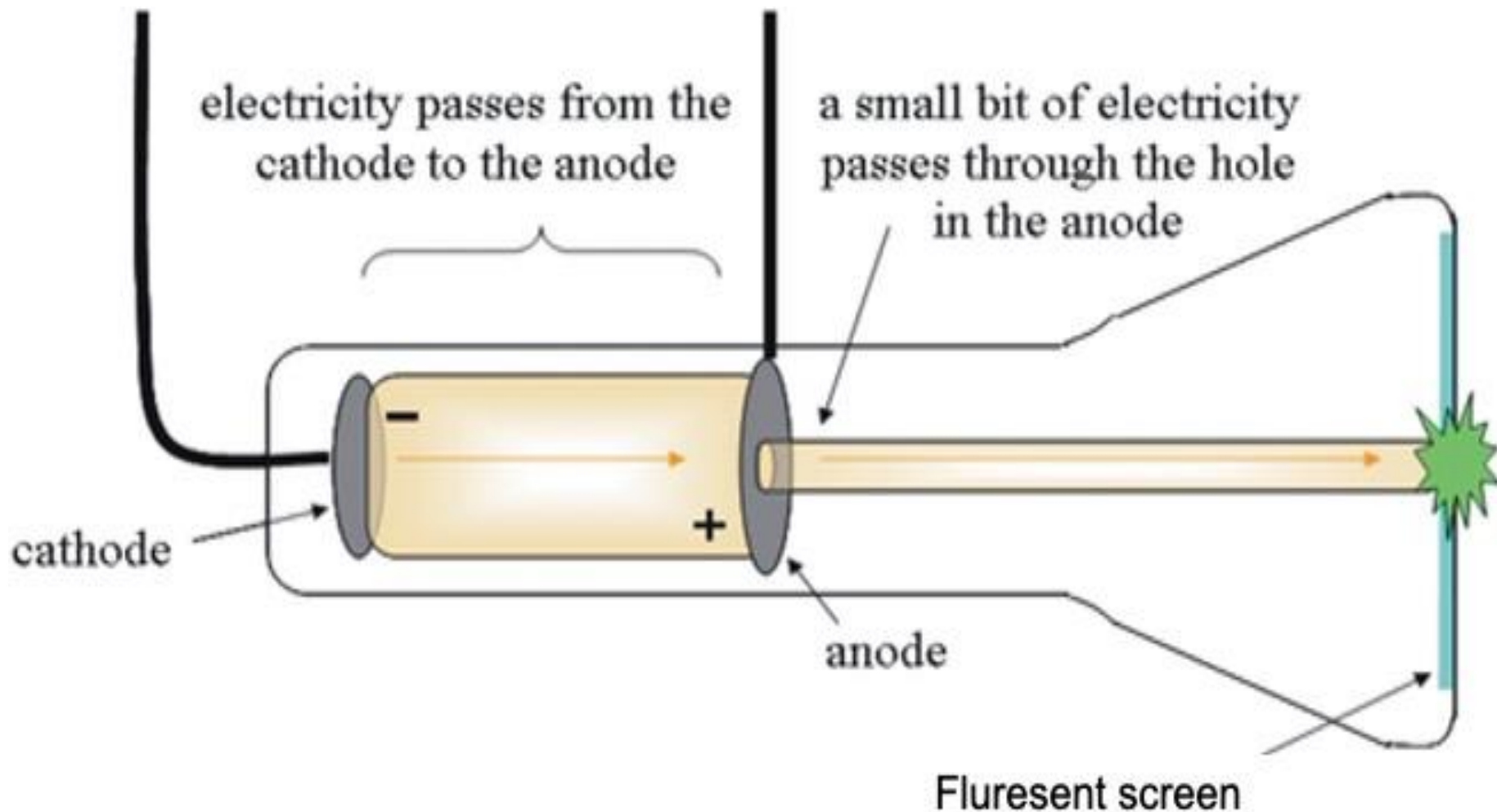

Cathode Rays' experiments

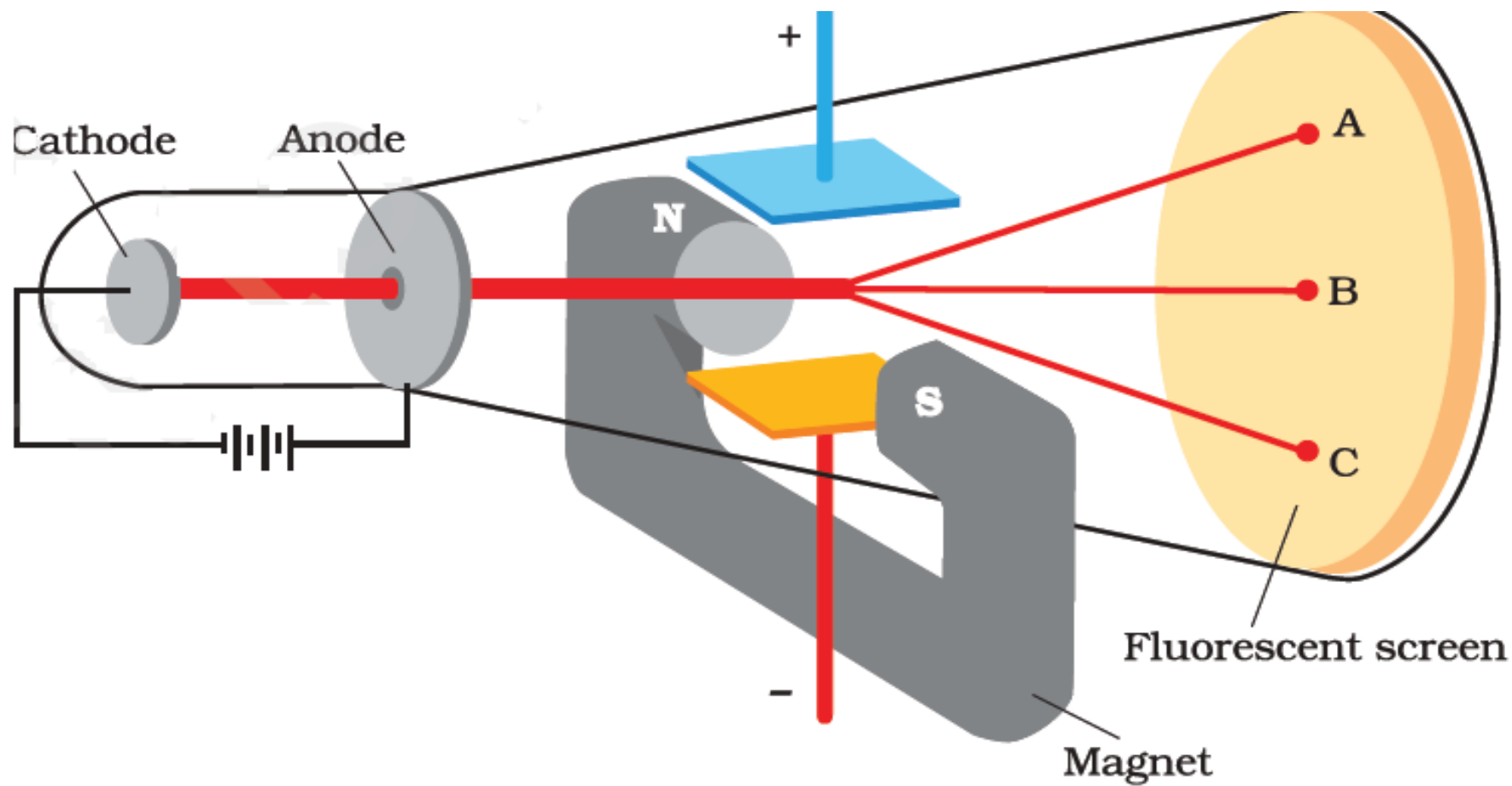

## Cathode Rays' experiments

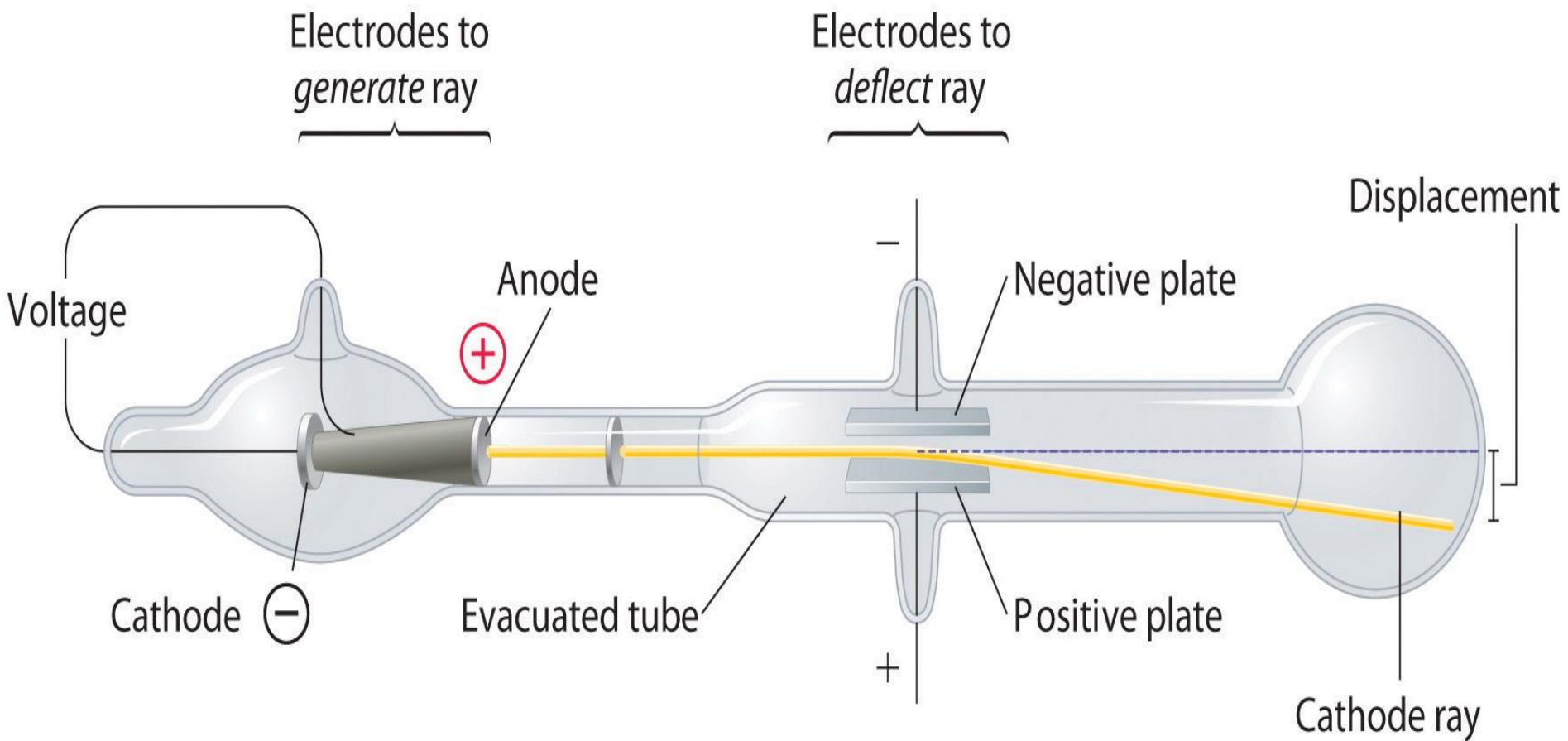

Cathode Rays' experiments

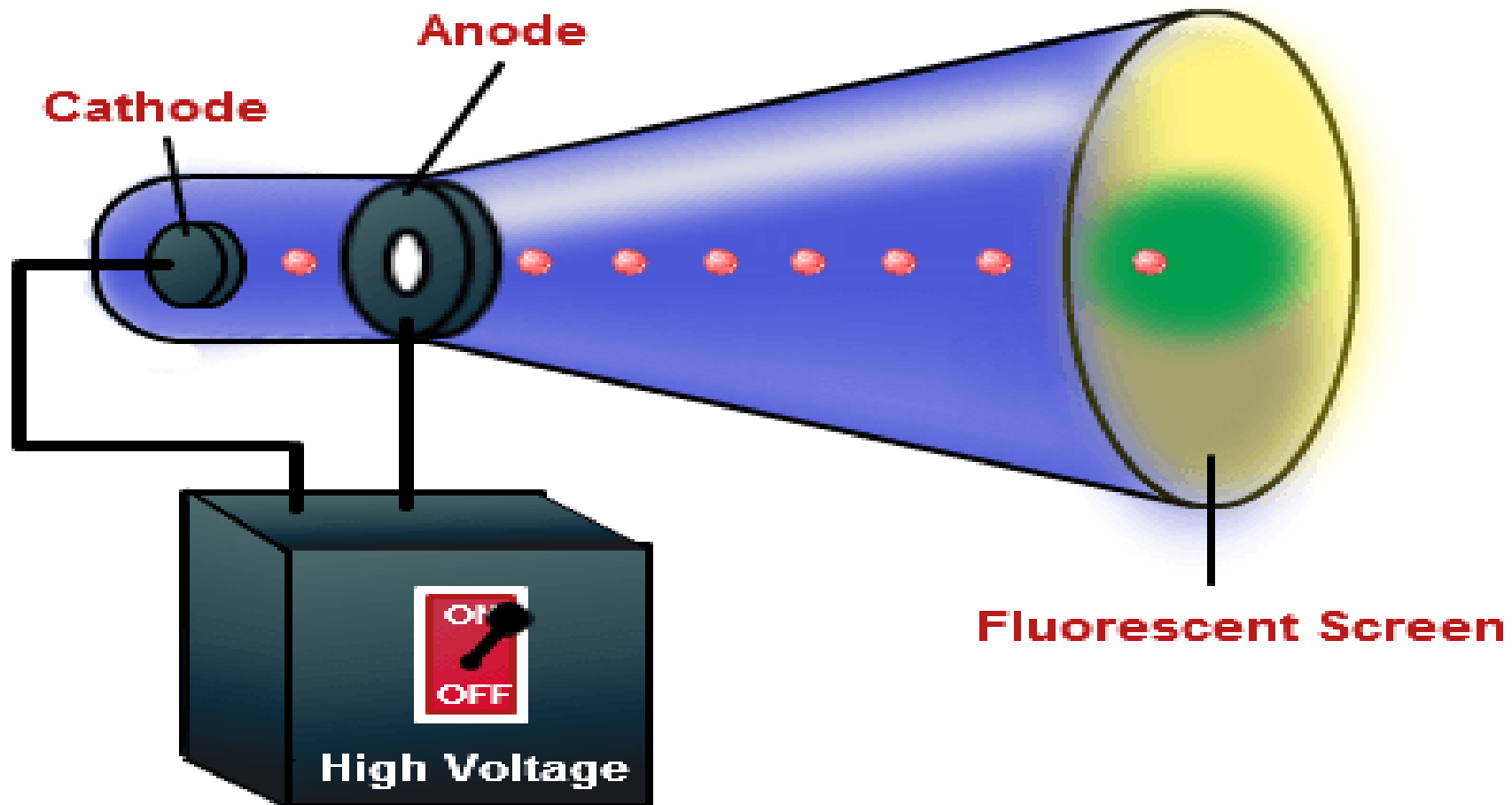



Cathode Rays' experiments

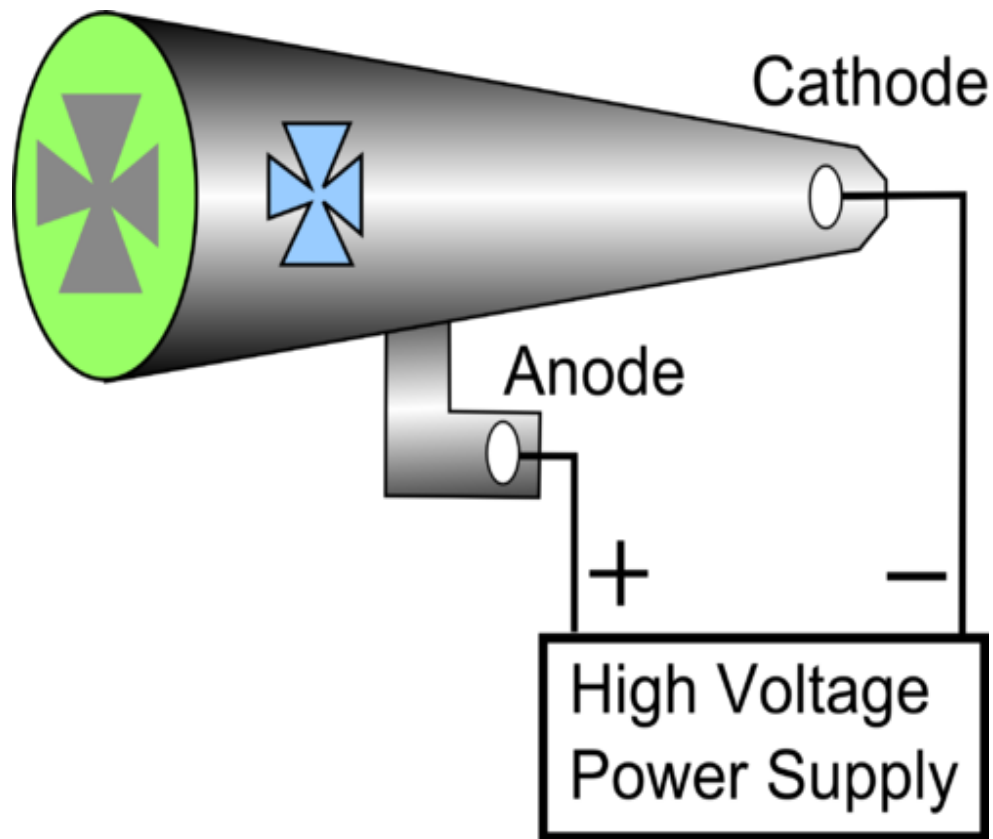

# Atomic Structure

## Thomson Model 1897

An atom is a spherical body of positive electricity that is permeated with negative electrons.

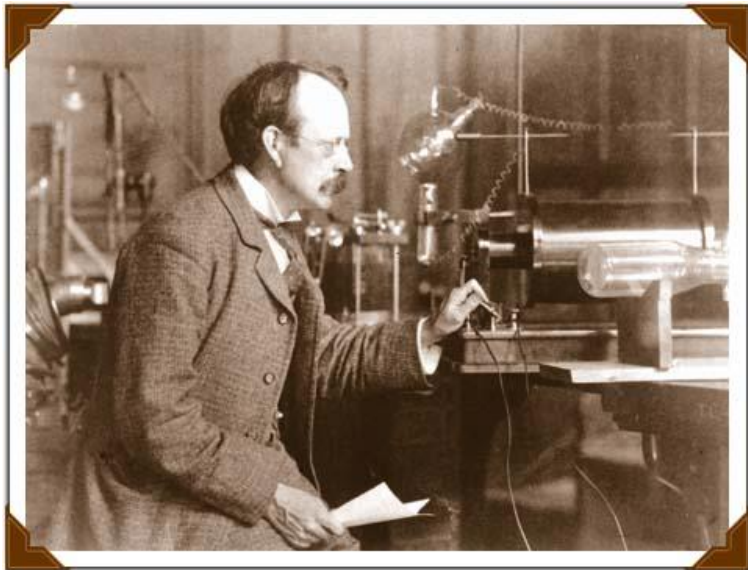

*John Joseph Thomson*

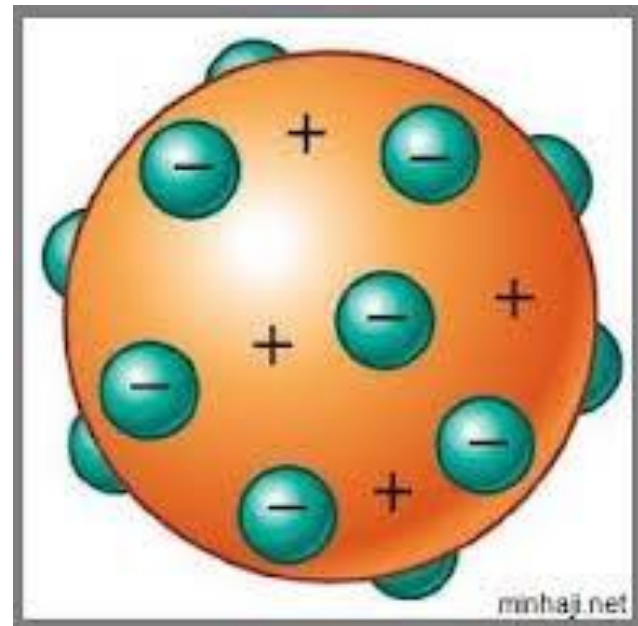

# Atomic Structure

## Thomson Model

$$e/m = - 1.76 \times 10^8 \text{ Colum / gm}$$

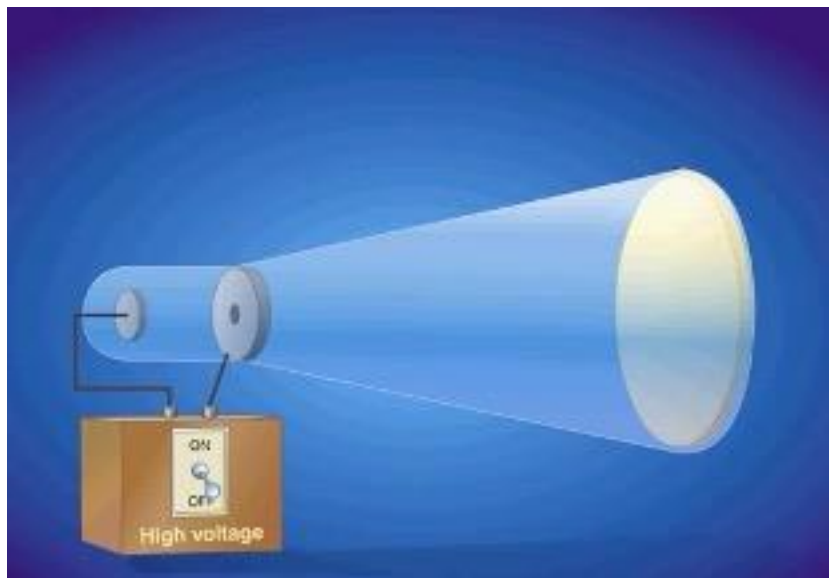

# Atomic Structure

## Millikan Experiment

$$e = - 1.602 \times 10^{-19} \text{ C}$$

$$m = 9.1 \times 10^{-28} \text{ g}$$

# Rutherford Model for Atomic Structure

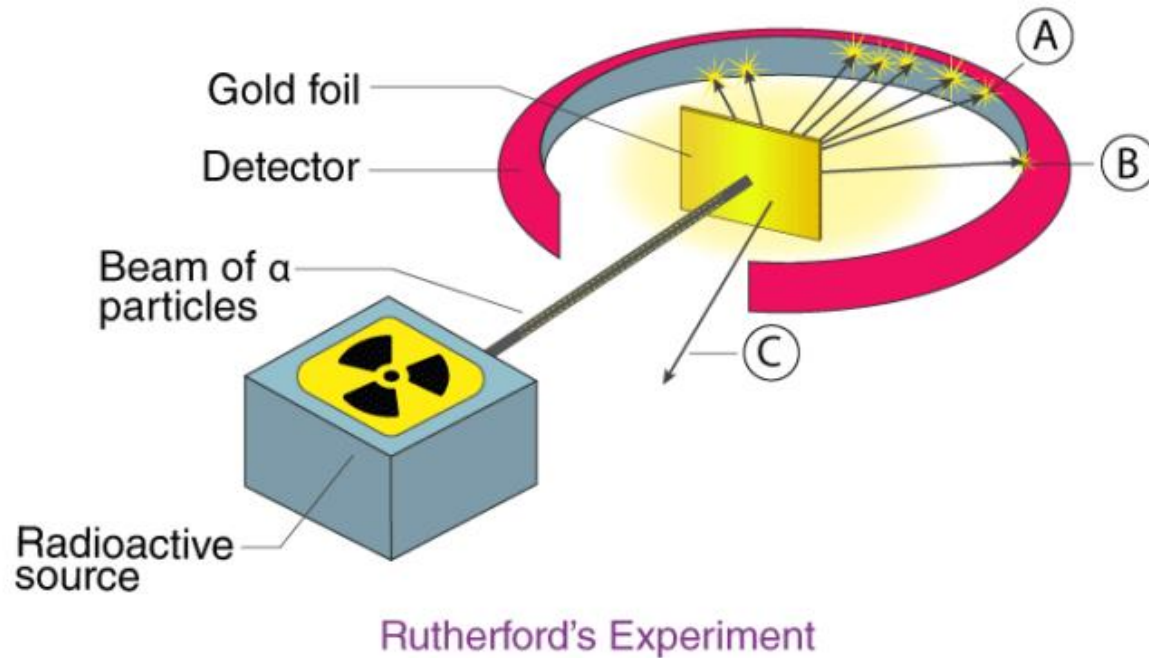



# Ernst Rutherford (1871-1937)

**Born:** August 30, 1871, Brightwater, New Zealand

**Died:** October 19, 1937, Cambridge, United Kingdom

**Discoveries:** Rutherford model, Atomic nucleus, Proton, and MORE

**Awards:** Nobel Prize in Chemistry, Copley Medal, Matteucci Medal, and MORE

**Nationality:** British, New Zealand

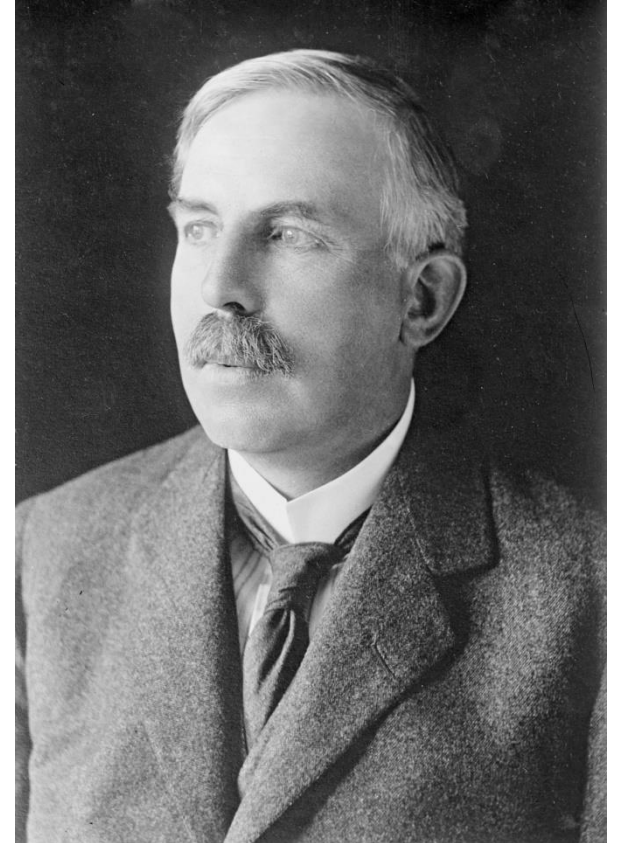

Ernst Rutherford (1871-1937)

# Rutherford Model for Atomic Structure.

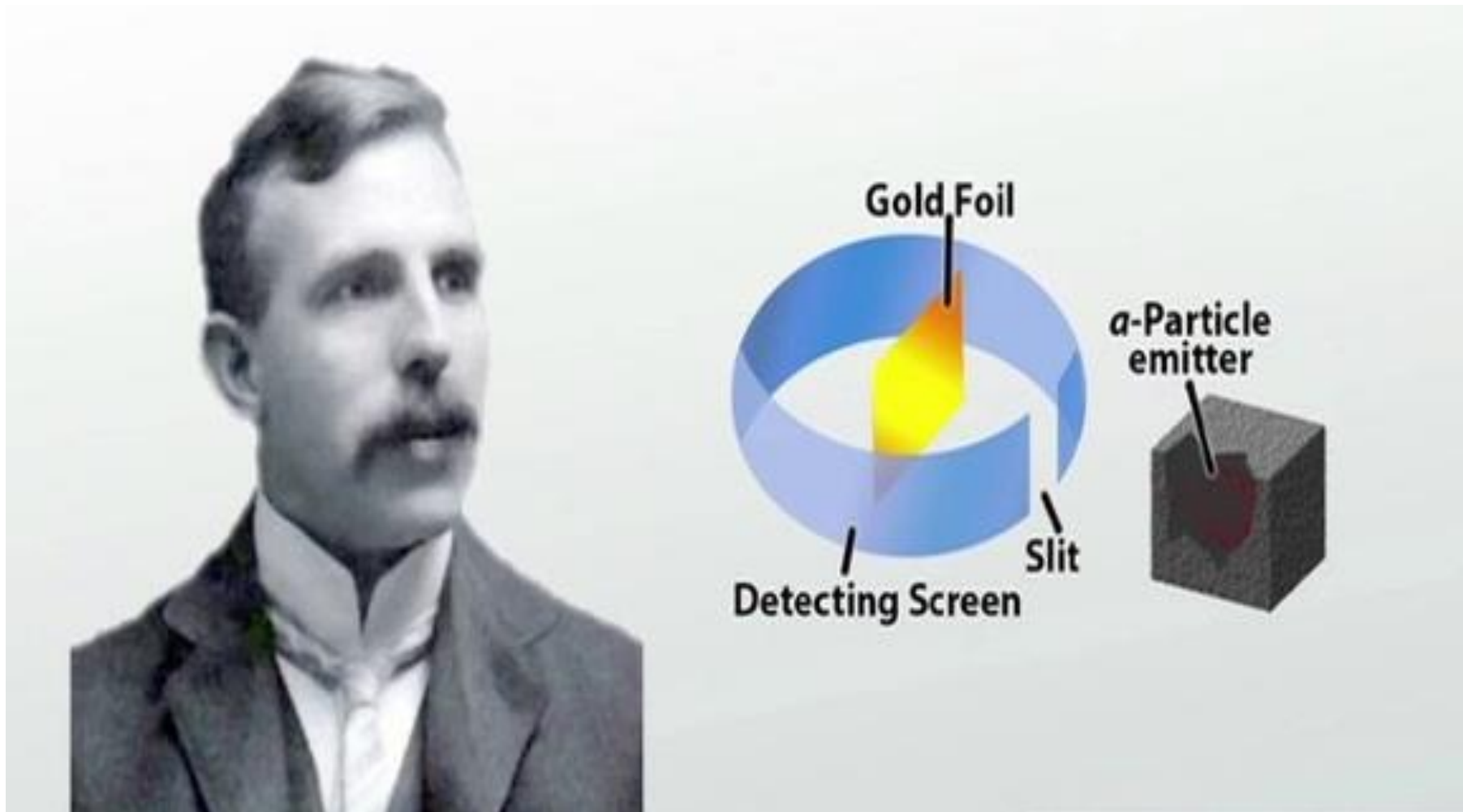

### Rutherford exp.

#### Equipment:

1. A metal plate covered with zinc sulfide (zinc sulfide gives a flash when alpha particles fall on it).
2. A source for alpha particles.
3. Thin slice of gold.

#### Procedures:

1. The alpha particles were allowed to collide with the metal plate lined with the zinc sulfide layer.
2. The location and number of alpha particles hitting the plate were determined from the flashes in the absence and presence of a thin plate of gold.

# Rutherford Model for Atomic Structure.

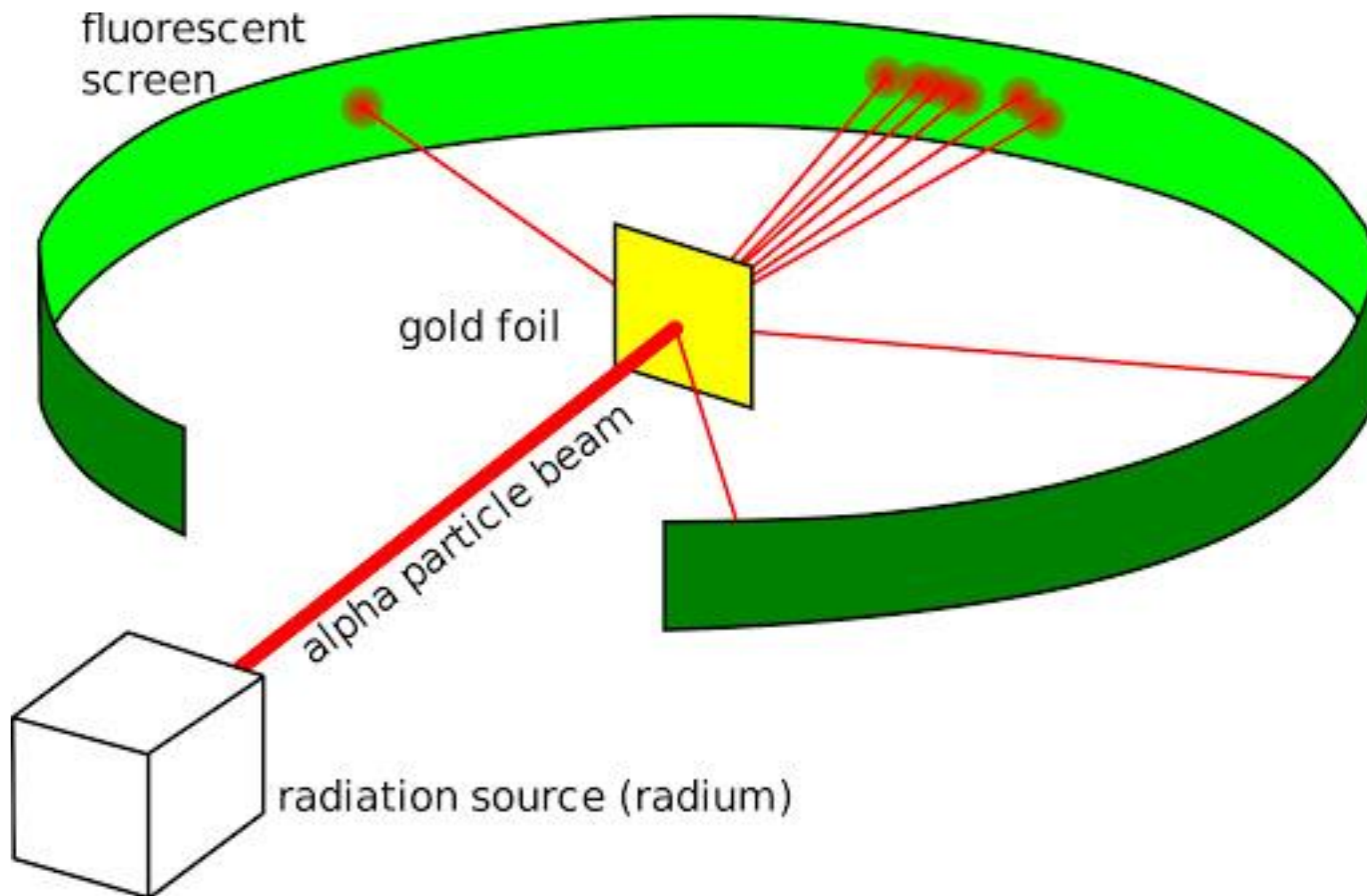

# Rutherford Model for Atomic Structure.

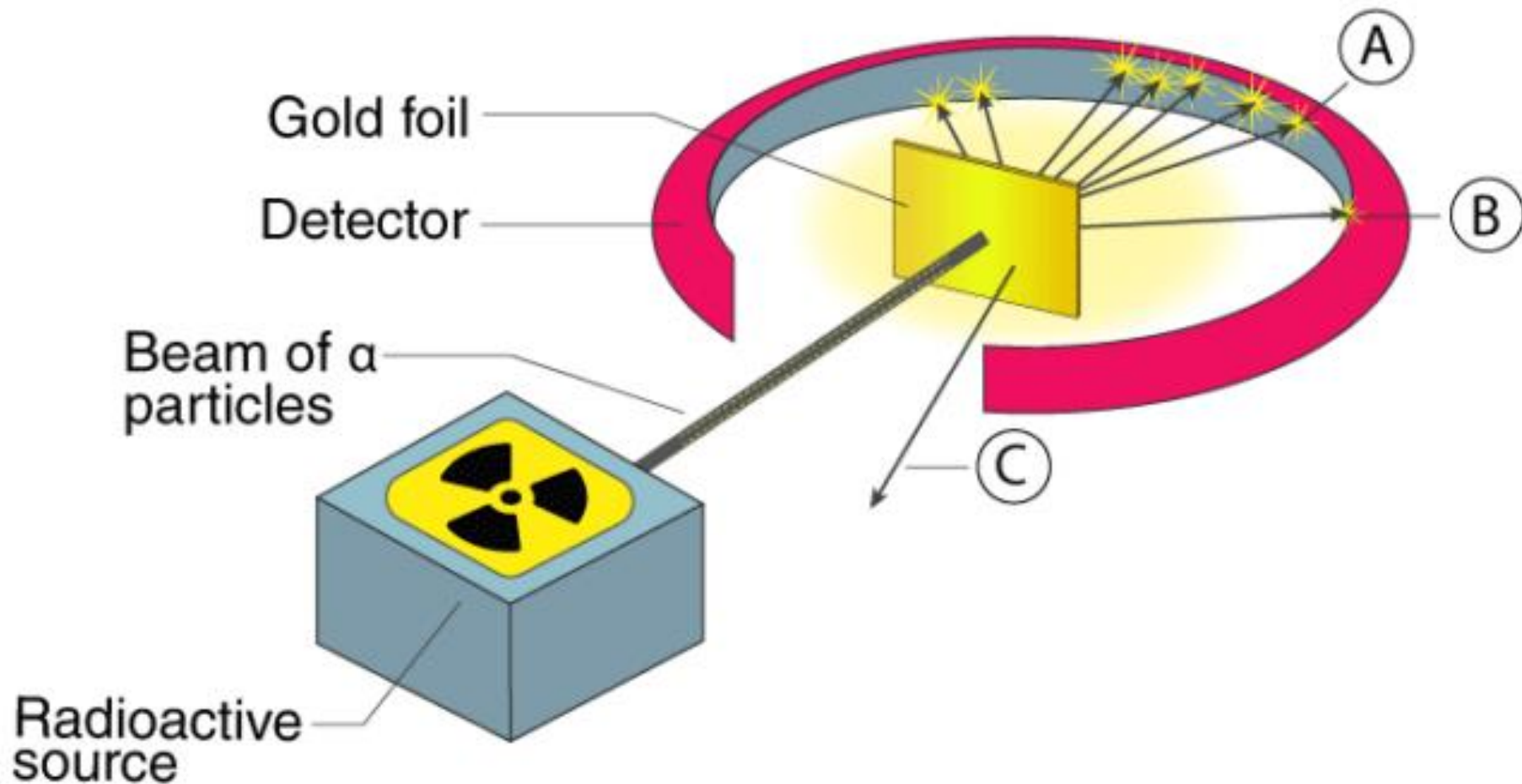

Rutherford's Experiment



# Rutherford Model for Atomic Structure.

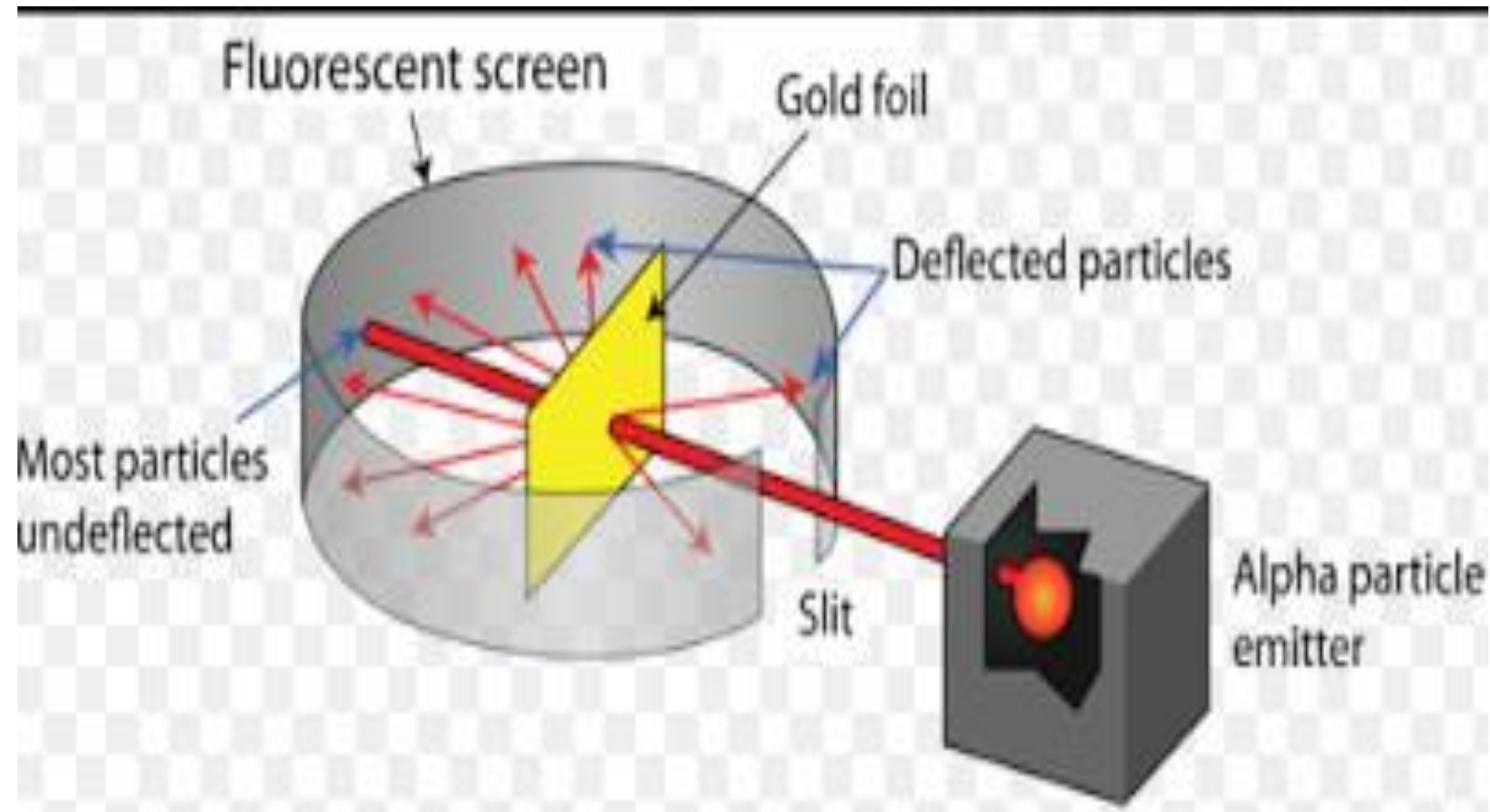

### **Notices of Rutherford Experiment:**

- 1. Most of the alpha particles passed straight through the foil without any deflection from their path.**
- 2. A small fraction of them was deflected from their original path by small angles.**
- 3. Only a few particles bounced back.**

# Rutherford Model for Atomic Structure.

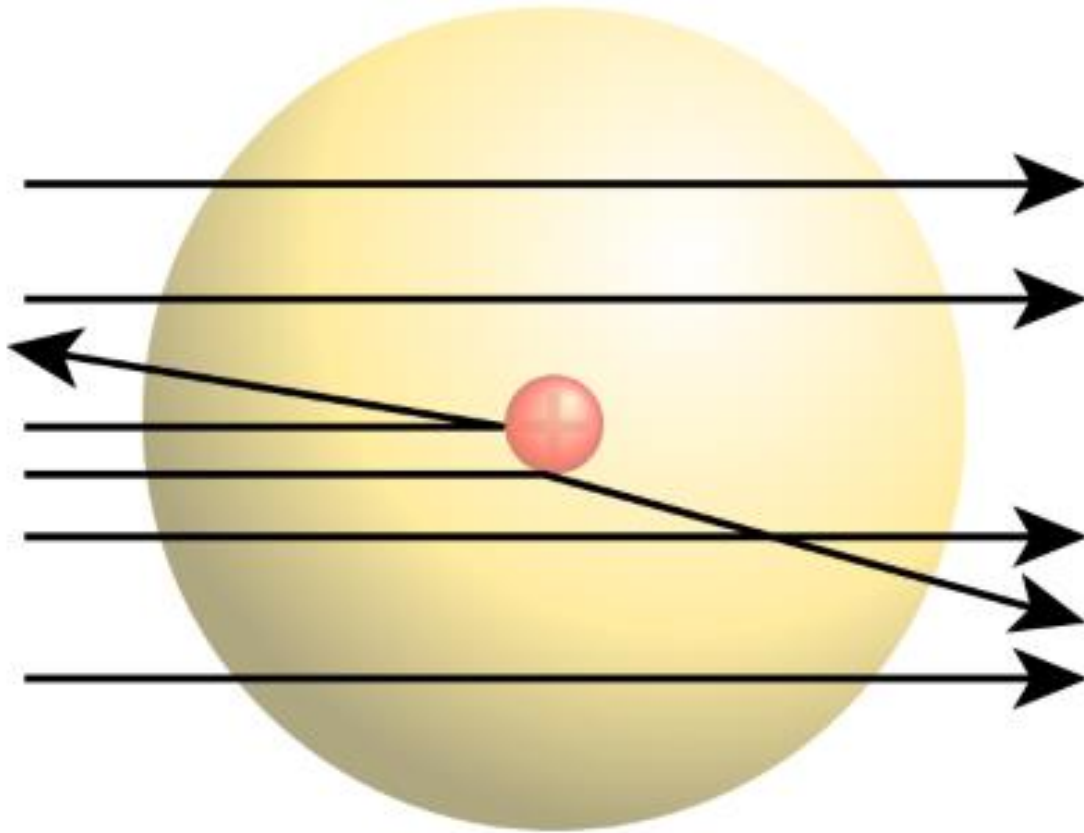

# Rutherford Model for Atomic Structure.

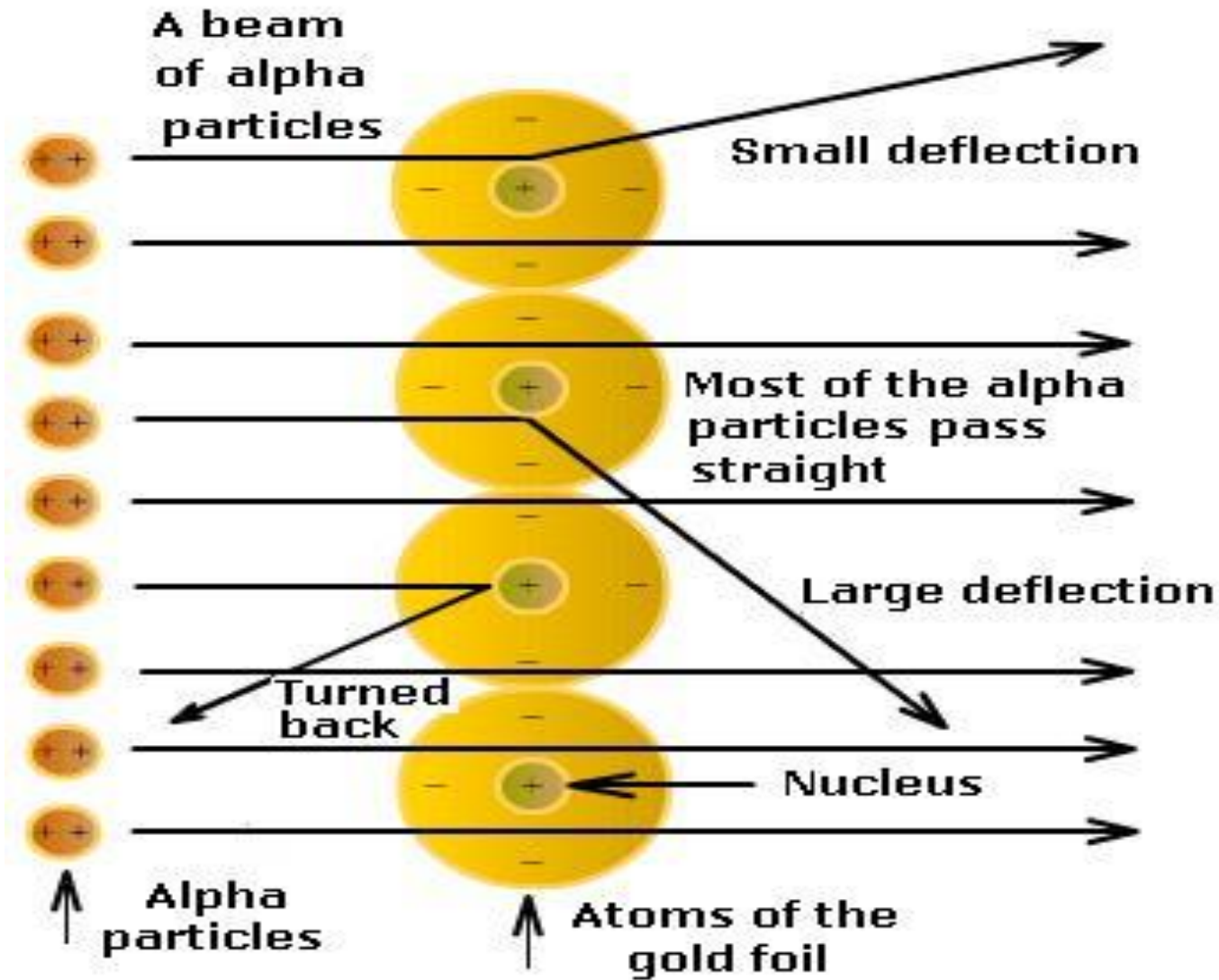

# Rutherford Model for Atomic Structure.

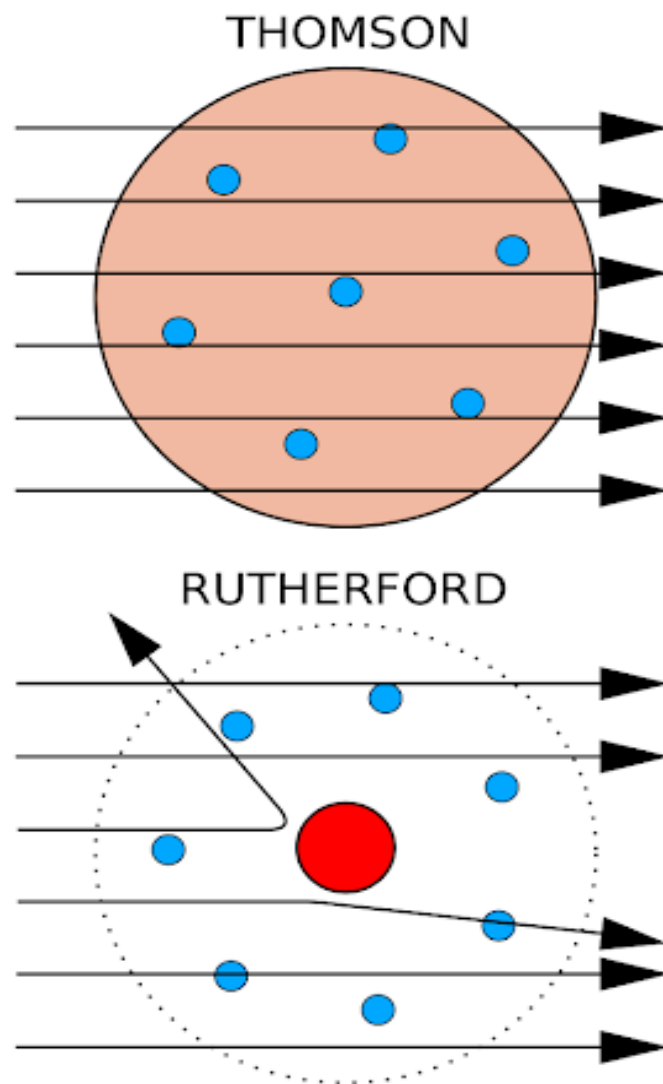



## Rutherford Model:

1. **Atom is a huge vacuum contains a central nucleus surrounded by negative electrons rotates around the nucleus and far away from it.**
2. **The atom mass is mainly contained at the nucleus which contains the positive charges as well.**
3. **Atom is electrically neutral, because it contains equal numbers of positive charges, at nucleus, and negative charges (electrons).**

## Rutherford Model:

4. As an electron rotates around the nucleus, a centrifugal force is created that is equivalent to the electron's attraction to the nucleus.

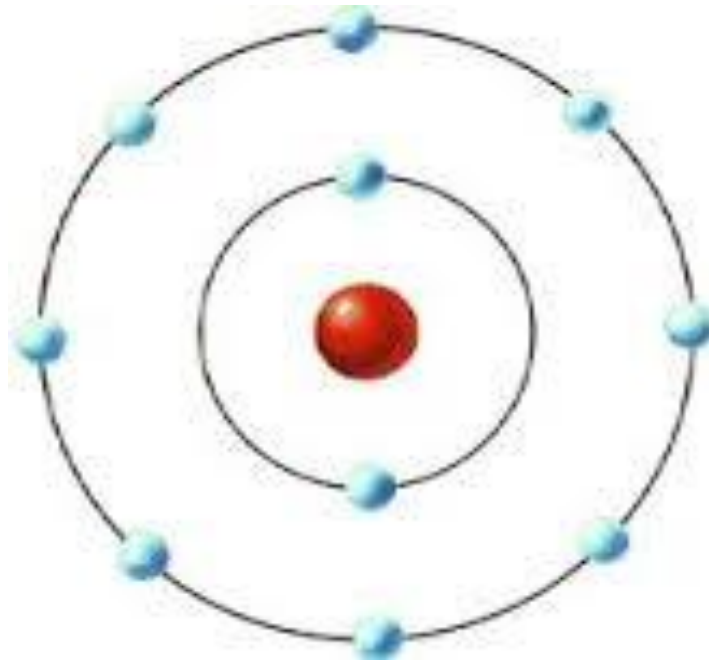

**Rutherford Atom**

# Discovering positive and neutral particles (proton, positron and neutron)

❖ Protons are positive and much heavier than electrons (Rutherford 1920).

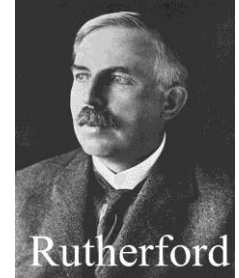

□ A neutron has a slightly heavier mass than a proton but is electrically neutral (Chadwick 1932).



Chadwick

✓ A positron has the same mass as an electron but is positively charged (Andersen 1932).

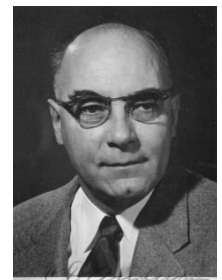

Andersen

# Quantum theory and the atomic spectrum

## Quantum theory and the atomic spectrum

- **Electromagnetic radiation consists of an electric and magnetic field that oscillate perpendicular to the direction of propagation of the radiation.**
- **The radiation travels in waves having a wavelength  $\lambda$  and a frequency  $\gamma$ .**

- **Wavelength ( $\lambda$ ):**

**It is the distance between two consecutive peaks or troughs.**

- **Frequency ( $\gamma$ ):**

**It is the number of vibrations produced for any object per second.**



# Quantum theory and the atomic spectrum

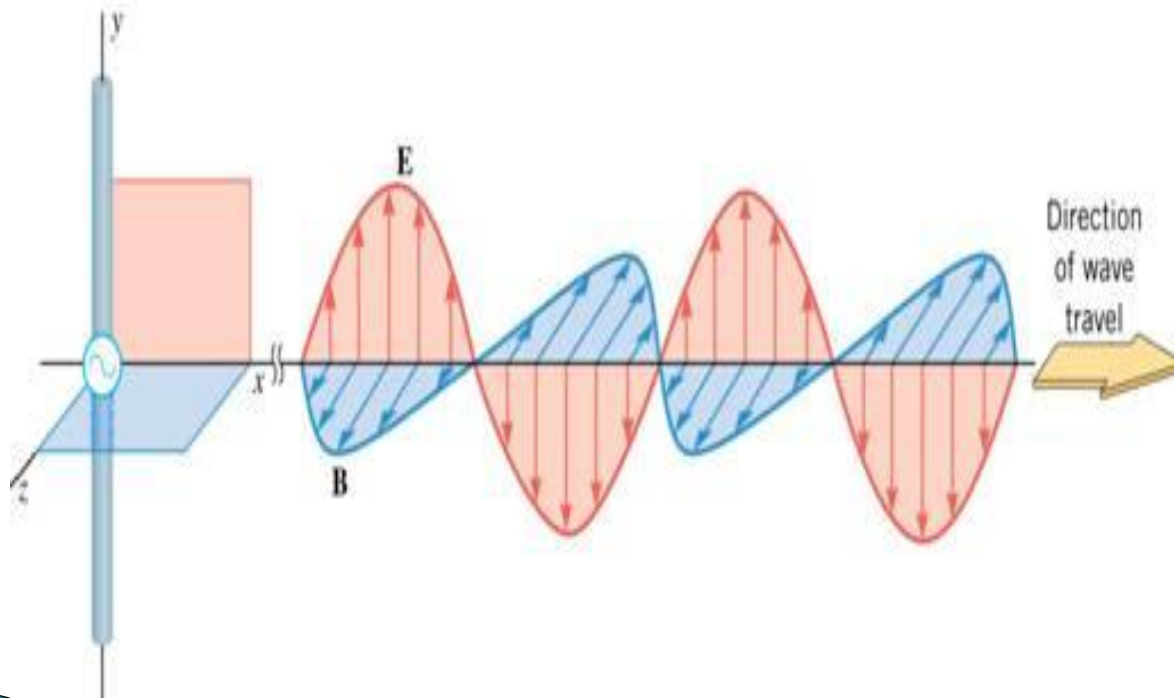
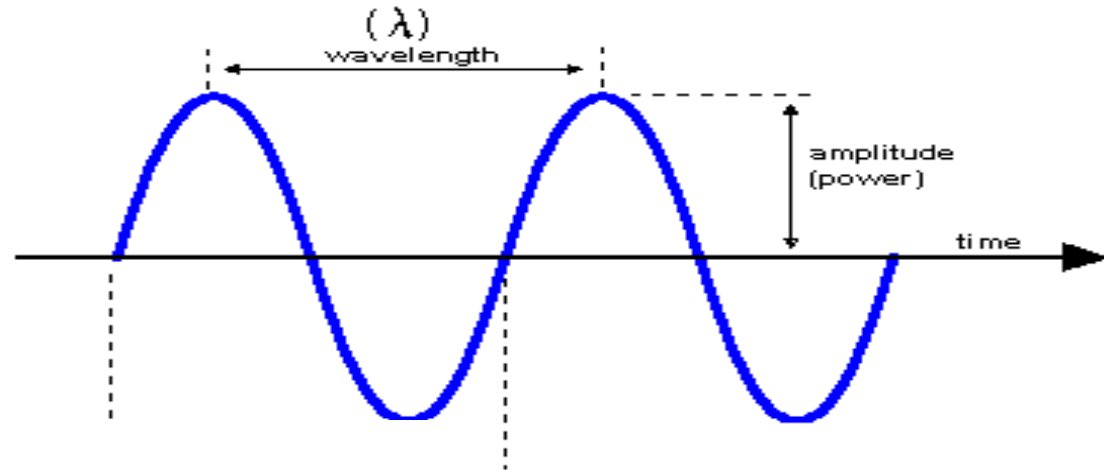

## Quantum theory and the atomic spectrum

Max Planck proved that an electromagnetic ray is not a flux or a constant current, but rather it is in the form of a quantum or quantum of energy. And it has an energy (E) estimated by Max Planck's law

$$E = h \gamma$$

$\gamma$  = frequency

$h$  = Max Planck's constant

Einstein suggested that the beam consists of infinitesimal minutes that he called photons having energy:

$$E = mc^2$$

$E$  = Photon's Energy  $m$  = Photon's mass.  $c$  = Light speed.

## Quantum theory and the atomic spectrum

- ❖ **When gas molecules or atoms of the element are heated, it produces electromagnetic radiation, when analyzing it, we get a number of parallel spectrum lines in different regions (of different wavelengths).**
- ❖ **This spectrum is known as linear atomic spectrum and it varies from element to element.**
- ❖ **The complexity of the atomic spectrum increases with the number of electrons of the element.**
- ❖ **There is a relationship between the atomic spectrum of excited atoms and their internal structure.**

## Quantum theory and the atomic spectrum

Spectra resulting from the scattering of the white ray through the glass prism:

**Red** - orange - **yellow** - green - blue - indigo - violet

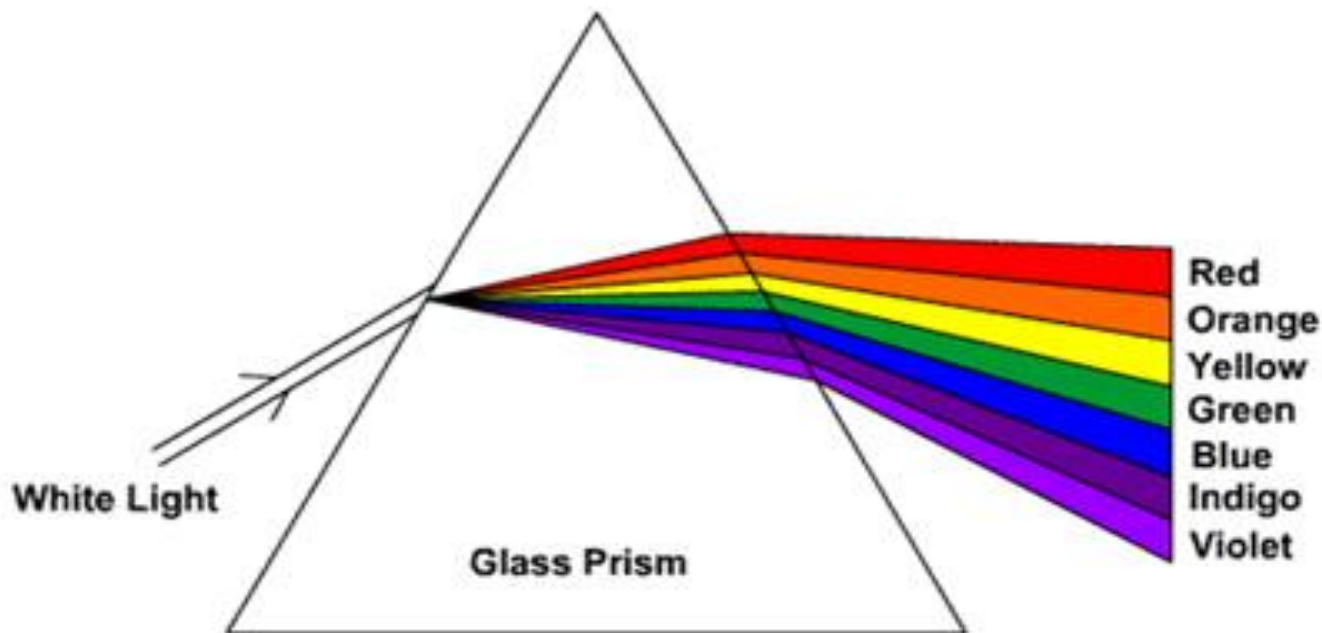

There is a relationship between the atomic spectrum of excited atoms and their internal structure.

## Quantum theory and the atomic spectrum

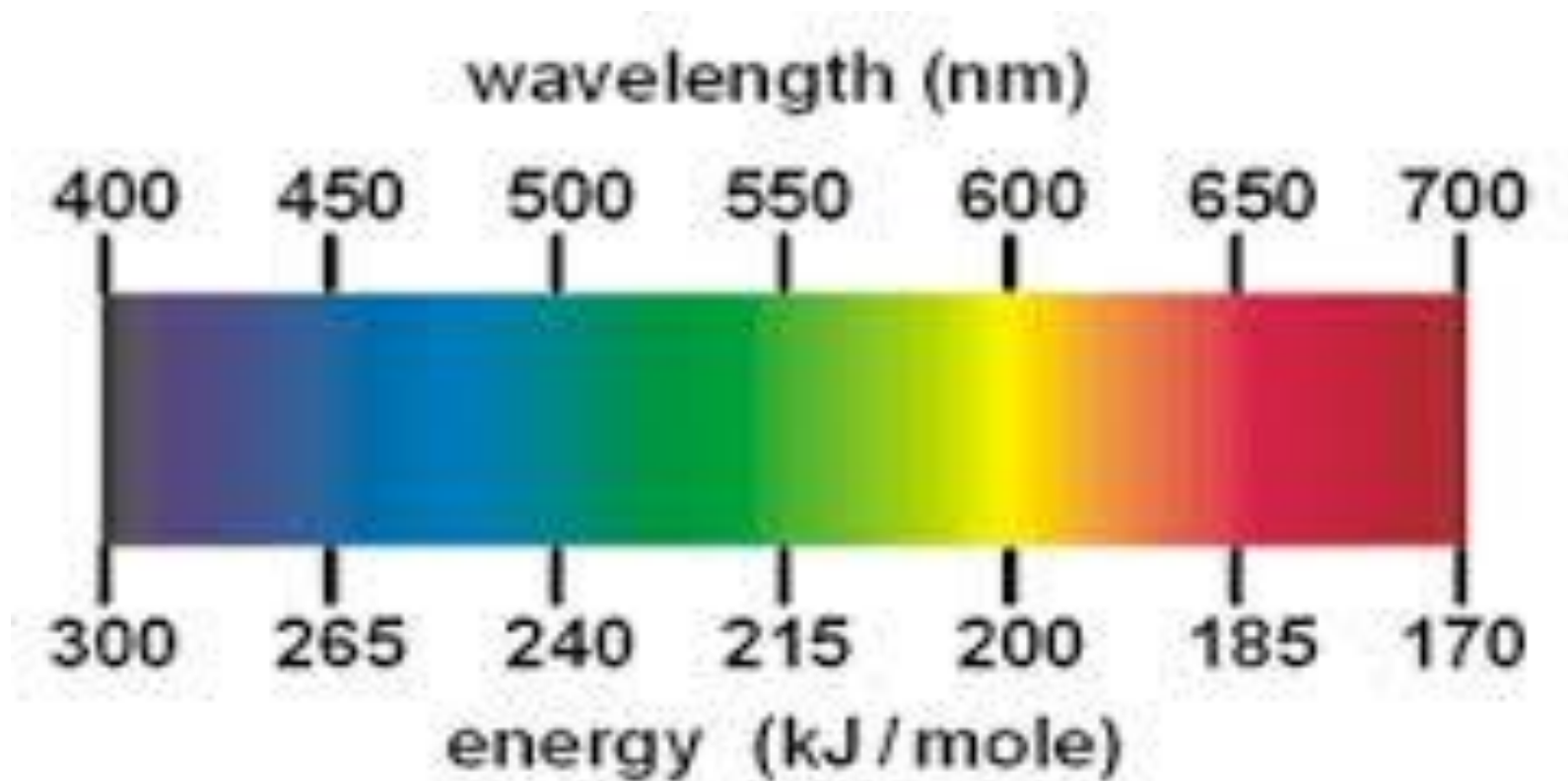

## Quantum theory and the atomic spectrum

Benefits of the emission spectrum include identification of elements and compounds (Linear spectrum of elements such as a human fingerprint).

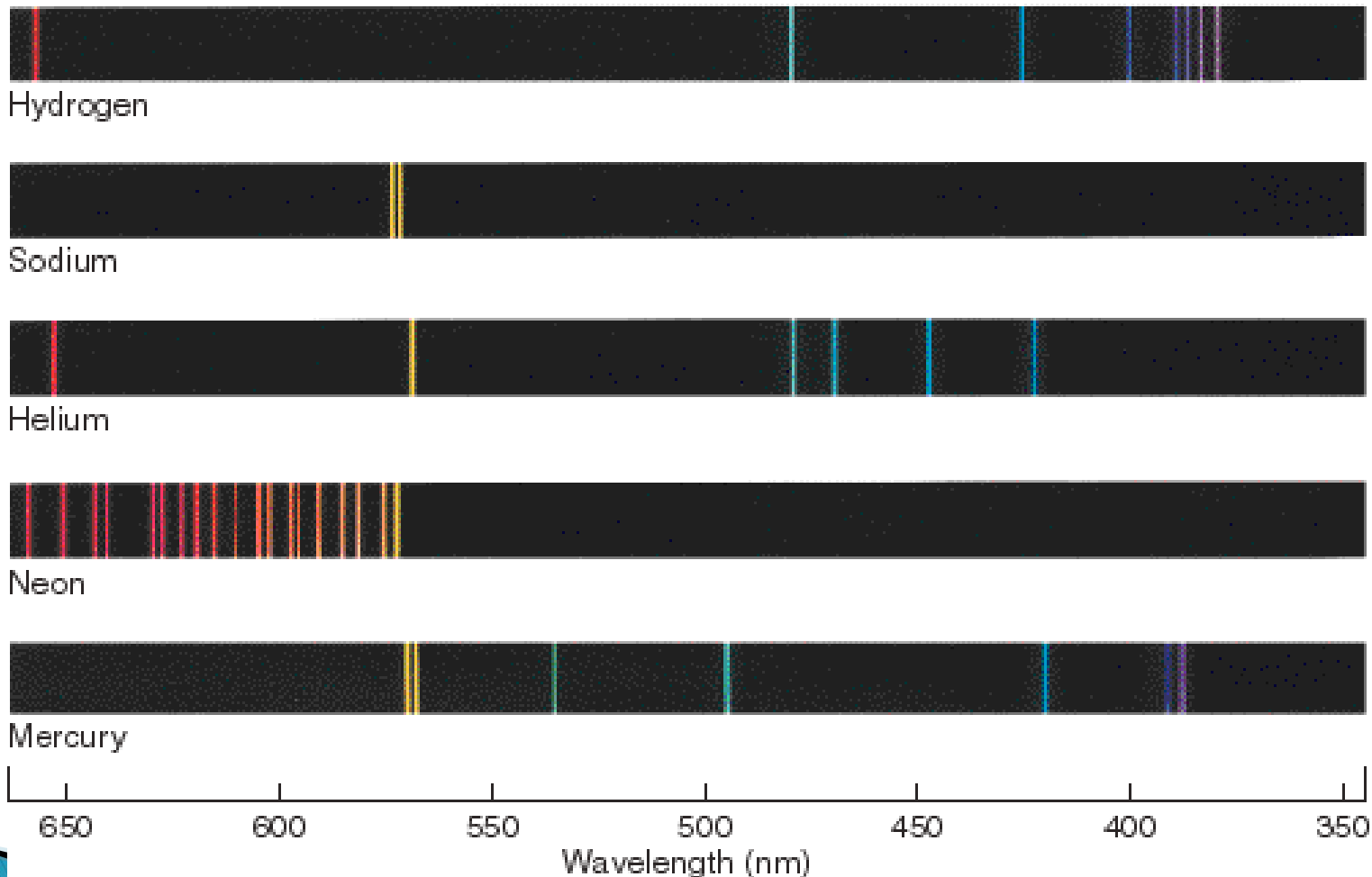



# Bohr Atomic Model

- ❑ The electron orbits the nucleus at a finite number of constant and specific energy levels without losing or gaining energy in the normal state of an atom.
- ❑ Each electron during its rotation around the nucleus has a specific energy that depends on the distance of the energy level in which it rotates from the nucleus, as the energy level increases with the increase of its radius.
- ❑ The largest number of energy levels in the normal state of an atom, 7 levels, expresses the energy of each level with an integer number called the principal quantum number.

# Bohr Atomic Model

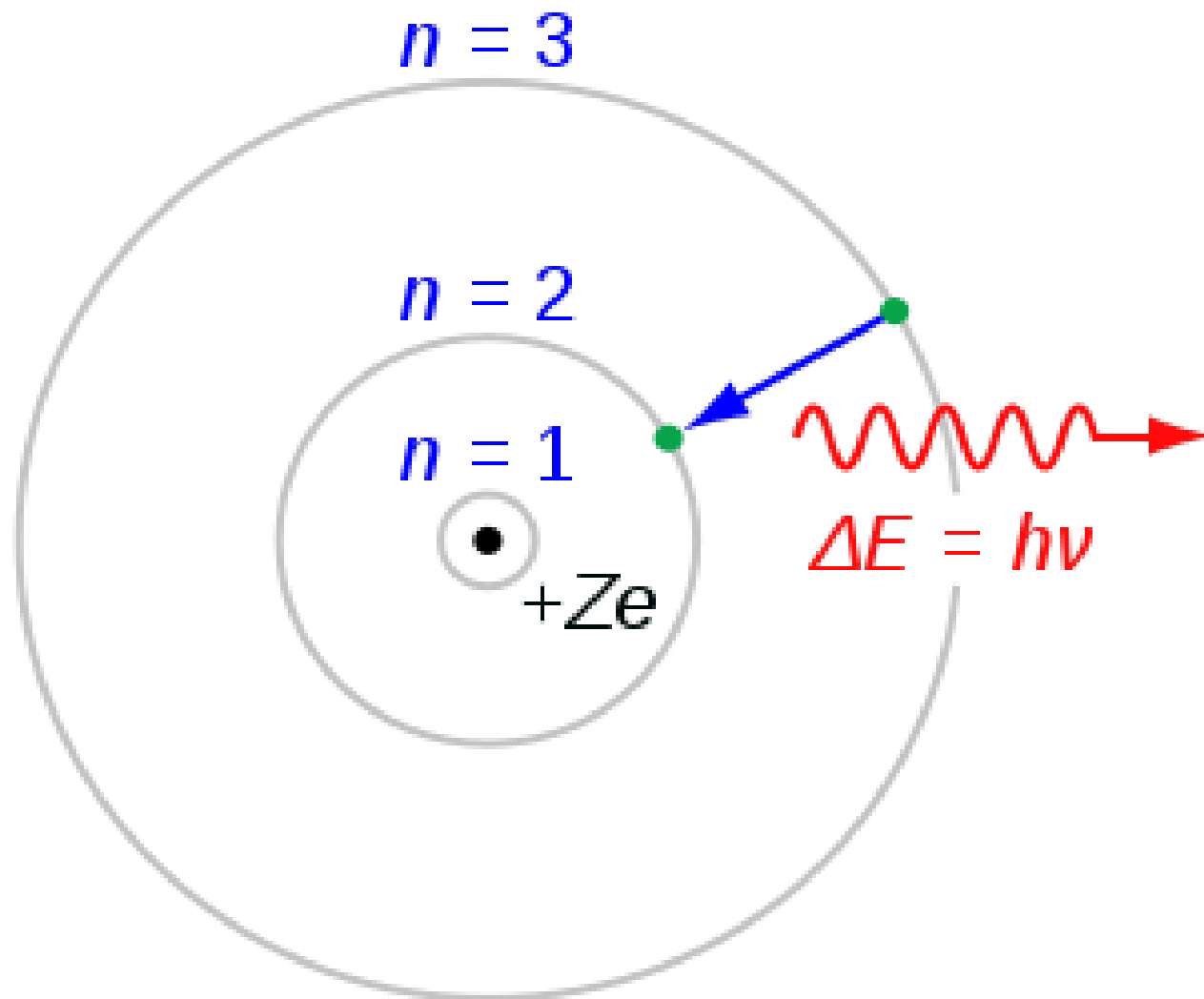

# Bohr Atomic Model

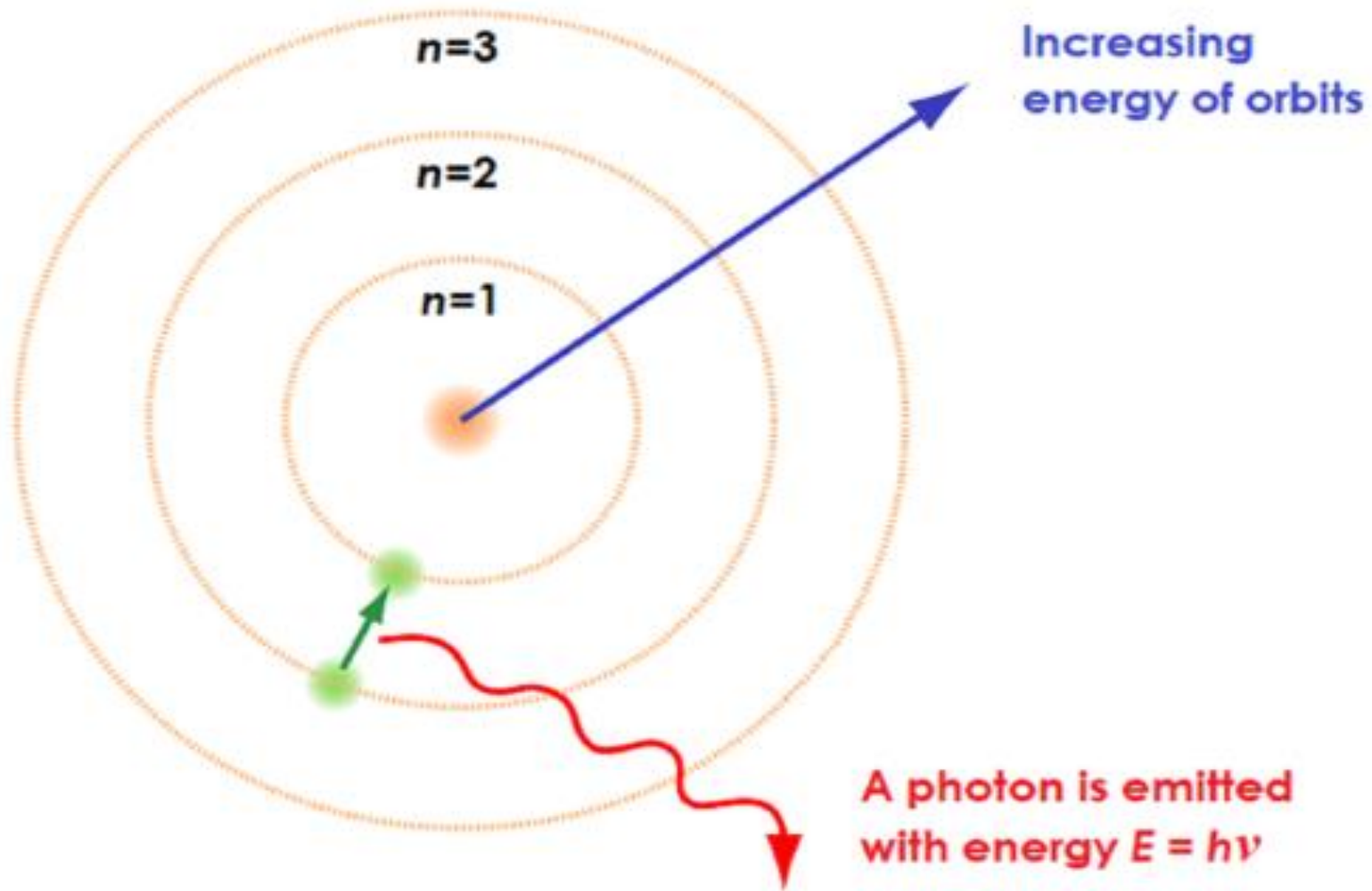

# Bohr Atomic Model

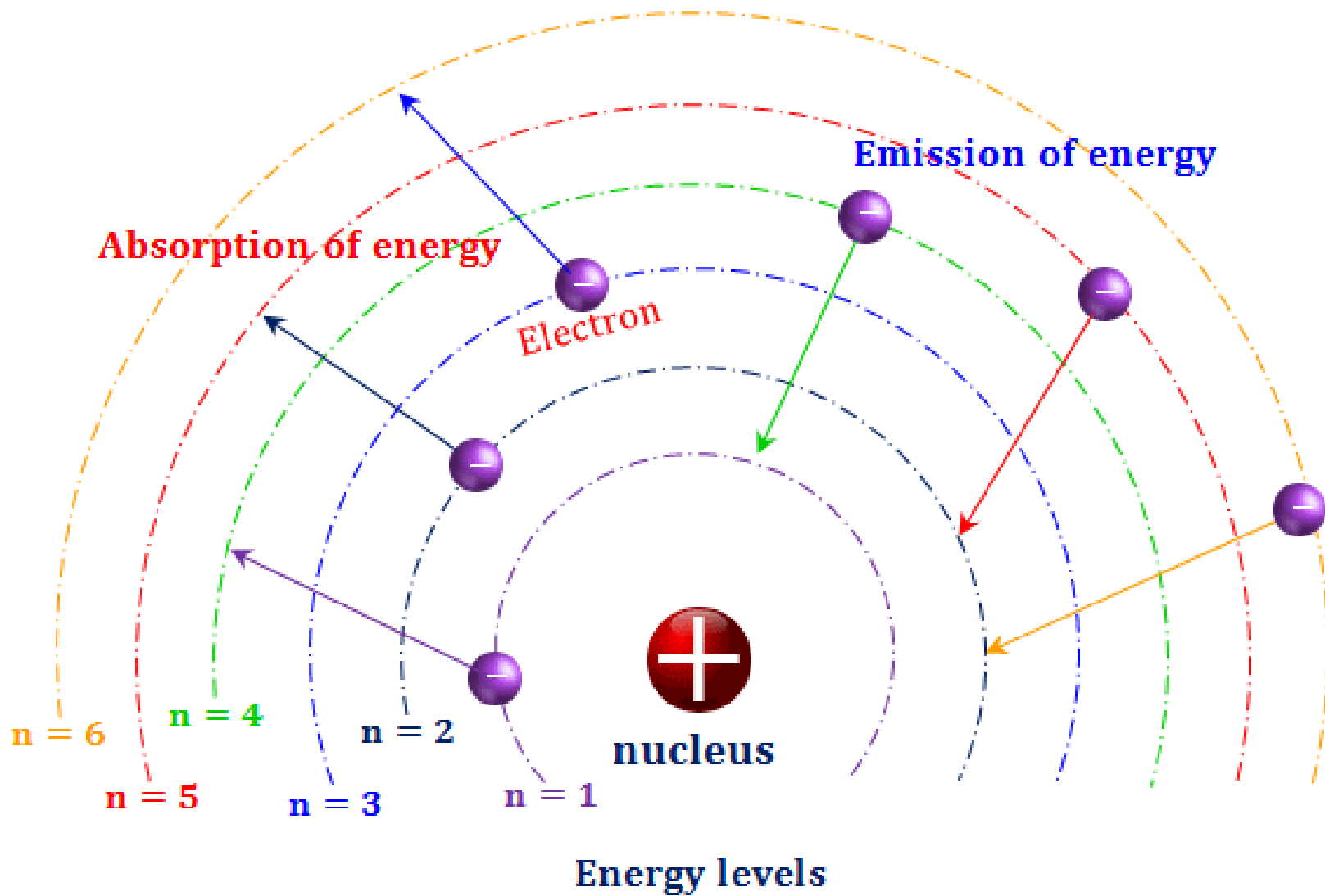

# Bohr Atomic Model

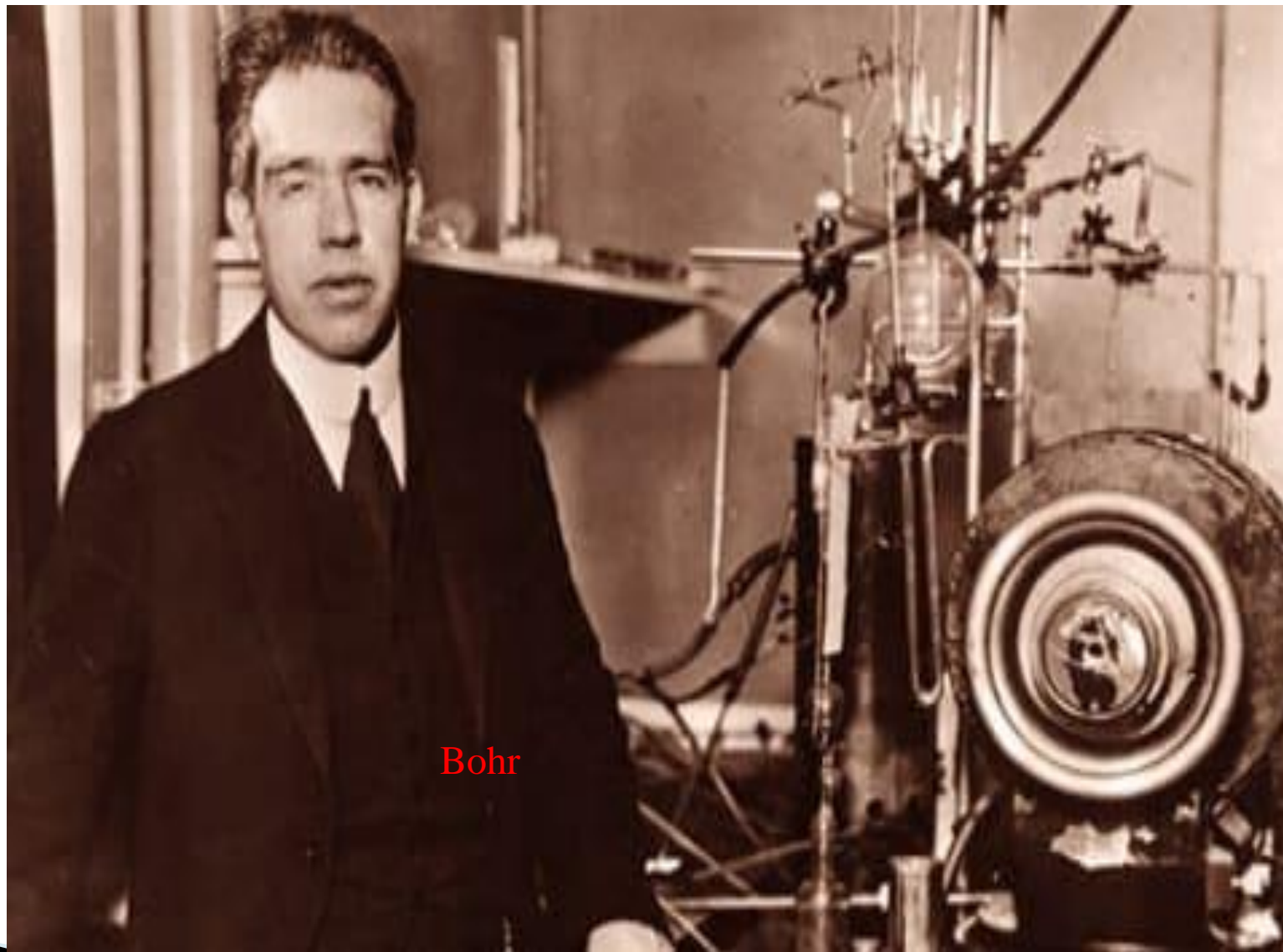

# Bohr Atomic Model

- In the stable state of the atom, the electron rotates at the energy level appropriate to its energy, and when the atom is excited, the electron temporarily jumps from its energy level  $E_a$  to a higher level  $E_b$ , and when it loses the excitation energy, the electron returns to its original location, giving radiation of a distinct wavelength and frequency for each element.
- The energy of the emitted photon is in the form of an electromagnetic spectrum equal to the energy difference between the two planes:

$$E_b - E_a = h\nu$$

Thus, Bohr was able to explain the origin of the linear spectrum of the elements.



# Bohr Atomic Model

- An electron does not move from one level to another unless the amount of energy gained or lost is equal to the energy difference between the two levels.
- As an electron rotates around the core, its angular momentum ( $mvr$ ) is a multiple of the value ( $h / 2\pi$ )

$$mvr = n \frac{h}{2\pi}$$

Where:  $h$ =Planck's constant,  $m$  = the mass of the electron,  $v$  = the velocity of the electron,  $r$  = the radius of the orbital, and  $n$  = the number of the orbit.

- So, Bohr was able to calculate the radii of electronic orbits and the total energy Of the electron and the energy differences between the orbitals.

## Disadvantages of the Bohr model

- The theory refers to knowing the exact position of the electron and its velocity, which is not possible and does not agree with Heisenberg's principle of uncertainty, which states that it is impossible to know at the same time the amount of motion and location of a moving particle.
- Bohr was not interested in the wave nature of the electron and considered it only a physical body, and it has been proven that electrons are similar to light in that they have a dual nature (wave and particle).
- Bohr used flat planes (that is, in one plane), which means that the hydrogen atom is flat. This is the opposite of the truth, as the atom has three directions in space.
- Bohr's theory did not succeed in explaining the more complex spectra of the hydrogen atom, i.e. the spectra of atoms with more than one electron.

# The efforts that led to the development of Bohr's theory and the arrival of the modern atomic theory

## 1. The wave nature of the electron: (de-Brawley's equation):

❖ An electron, like light, diffuses and interferes, so it has a dual nature (particle and wave) and not just a particle.

❖ Scientist De Brawley was able to derive an equation to calculate the wavelength of an electron wave.

$$\lambda = \frac{h}{mv}$$

❖ Where;  $h$  = Planck's constant,  $m$  = the mass of an electron, and  $v$  = its velocity.

❖  $mv$  expresses the particle of the electron, and  $\lambda$  expresses its wave nature.

❖ **Electron diffraction** has great uses in the study of crystal and molecular structure and imaging.

**The efforts that led to the development of Bohr's theory and the arrival of the modern atomic theory**

## **2. Heisenberg's Uncertainty Principle**

**It is impossible to know at the same time the momentum and location of a moving particle.**

$$(\Delta x)(\Delta mv) \geq \frac{h}{2\pi}$$

**$\Delta x$  = the amount of uncertainty with respect to the electron's position.**

**$\Delta mv$  = the uncertainty of the amount of traffic.**

**That is, if the location of the electron is precisely determined, it is not possible to accurately determine the amount of its motion, and vice versa.**

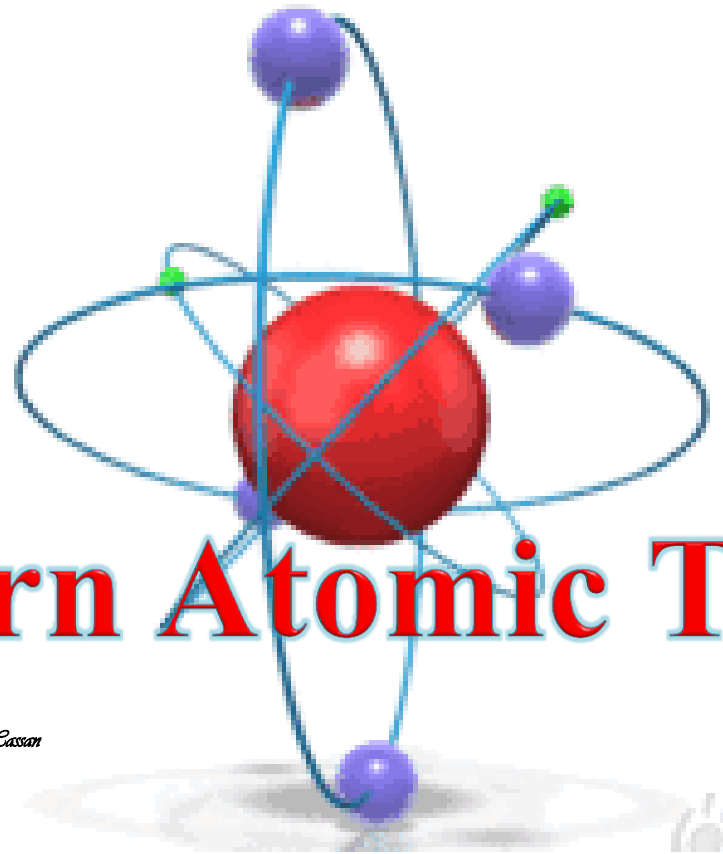

# Modern Atomic Theory

*Dr. Ibrahim A. I. Hassan*

## Modern Atomic Theory

- **An atom consists of a nucleus containing a positive charge and most of the mass of an atom is concentrated in it.**

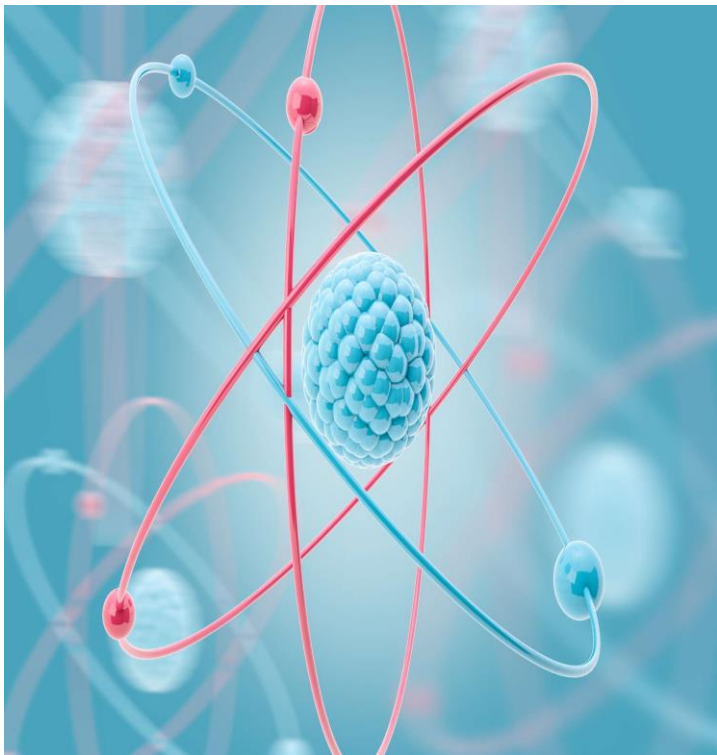

- **The nucleus is surrounded by negatively charged electrons that move very quickly and have the properties of waves.**
- **Electrons occupy the void regions around the nucleus and have certain energies and are found in what is known as an electronic cloud.**



## Modern Atomic Theory

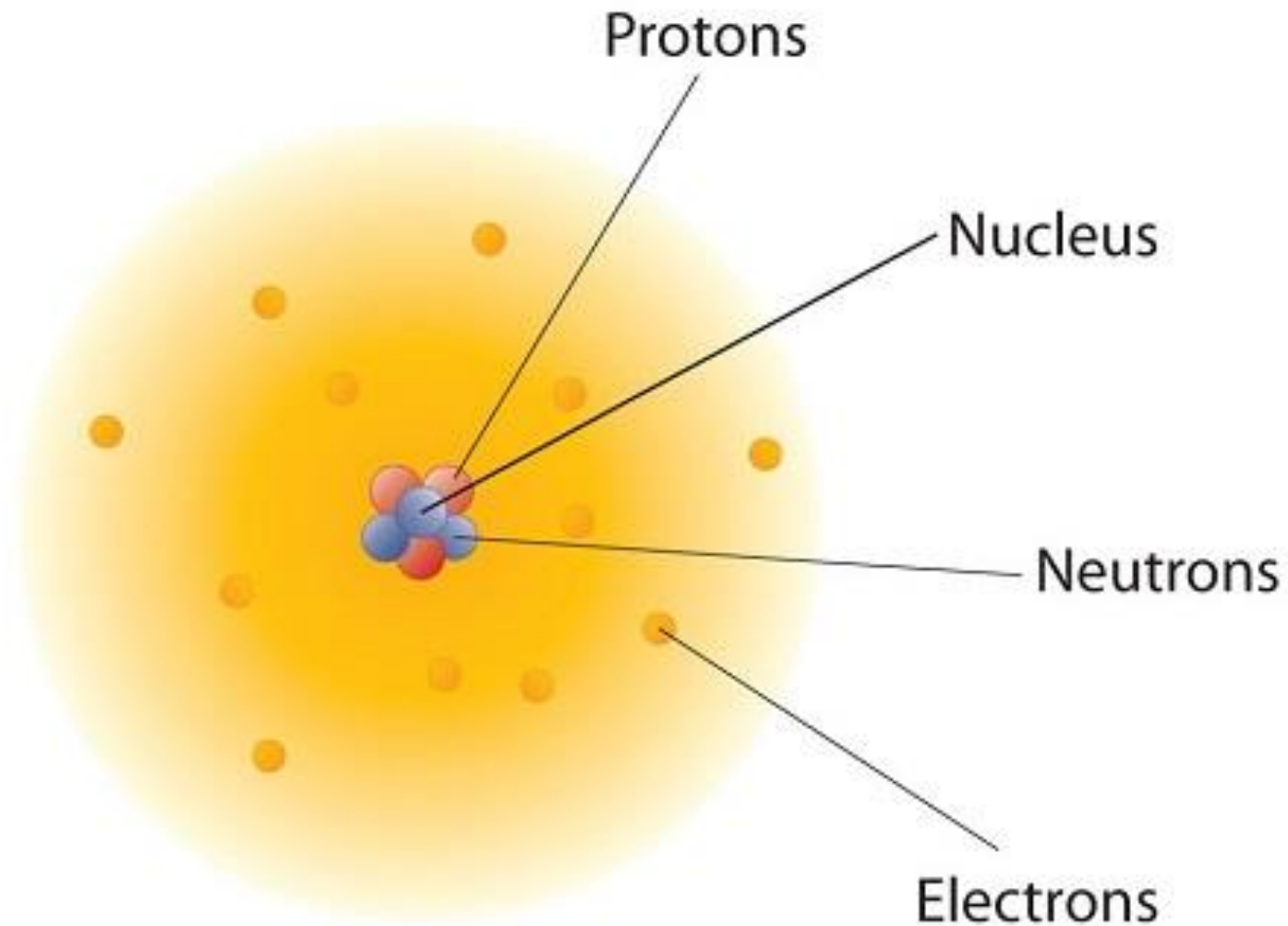

# Modern Atomic Theory

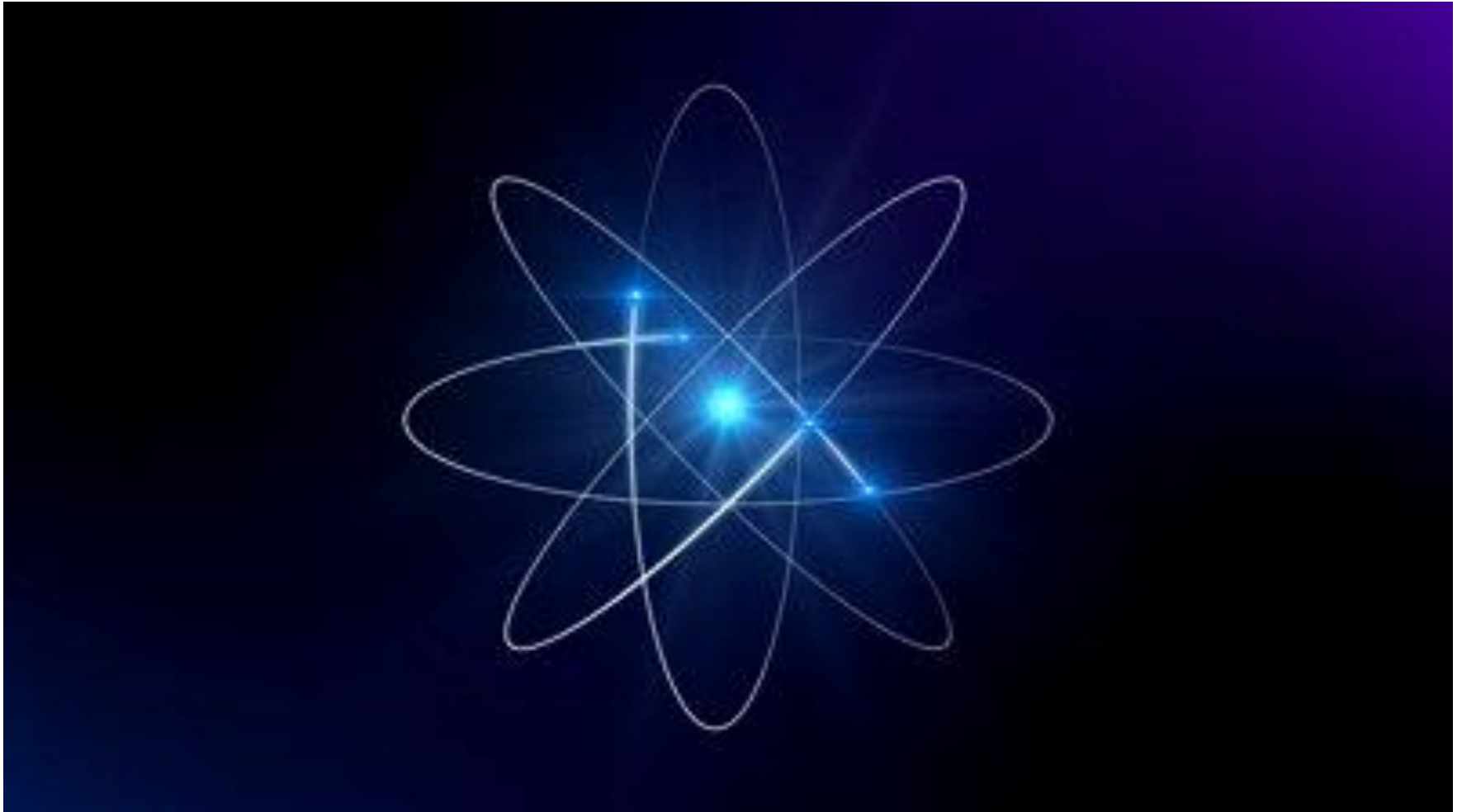

# Quantum numbers:

It describes the movement of electrons in an atom and determines its location.

1. **Principal quantum number (n):**

- It indicates the energy level.
- Shows the size of the electronic cloud.
- Its value is 1 - 7 and does not take the value zero.
- The seven energy levels take the symbols:

**K, L, M, N, O, P, Q.**

## Quantum numbers and interstitial form of rotations

### 1. Principal quantum number (n):

- The number of electrons by which each principal energy level is saturated is twice the square of the shell number ( $2n^2$ ).

**e.g. The fourth level is saturated with 32 electrons ( $2 \times 4^2 = 32$ ).**

- This law does not apply to energy levels higher than the fourth because an atom becomes unstable if the number of electrons in any level exceeds 32 electrons.

**Quantum numbers and interstitial form of rotations:****2. Secondary quantum number ( $\ell$ ):**

- ❖ Indicates the location of the sub-energy level (below the principal energy level).
- ❖ It is a number whose value determines the shape of the shell in which the electron is moving.
- ❖ Its number equals the number of its main level.
- ❖ The number of sub-energy levels does not exceed four levels.
- ❖ The four sub-energy levels have the symbols S, P, d, and F.
- ❖ They differ in energy:  $F > d > P > S$ .
- ❖ A positive number less than  $n$  and takes the values (0, 1, 2, 3)  $\leq \ell \leq n-1$

**Quantum numbers and interstitial form of rotations:****3. Magnetic quantum number (m):**

- **Determines the shape and orientation of the orbital in space.**
- **Number of directions per orbital =  $(2\ell + 1)$ , where  $\ell$  is the value of the secondary quantum number.**
- **The magnetic quantum number ranges between  $+\ell$  &  $-\ell$ .**
- **In the case of the secondary S level it is:**

$$m = 2 \times 0 + 1 = 1$$

**Therefore, the S level has one-way direction in space and is the sphere around the nucleus.**



**Quantum numbers and interstitial form of rotations:****3. Magnetic quantum number (m):****□ In the case of the secondary level P:**

$$m = 2 \times 1 + 1 = 3 \quad (+1, 0, -1)$$

- Therefore, the P level has three directions in space.
- It consists of two connected bulges, each of them can accommodate an electron, which is difficult to be present when the bulges meet.

**Quantum numbers and interstitial form of rotations:****3. Magnetic quantum number (m):**

□ **In the case of the secondary level d:**

$$m = 2 \times 2 + 1 = 5 \quad (+2, +1, 0, -1, -2)$$

**Therefore, the d level has five directions in space.**

□ **In the case of the secondary level f:**

$$m = 2 \times 3 + 1 = 7 \quad (+3, +2, +1, 0, -1, -2, -3)$$

**Therefore, the f level has seven directions in space.**

**Quantum numbers and interstitial form of rotations:**

## 3. Magnetic quantum number (m)

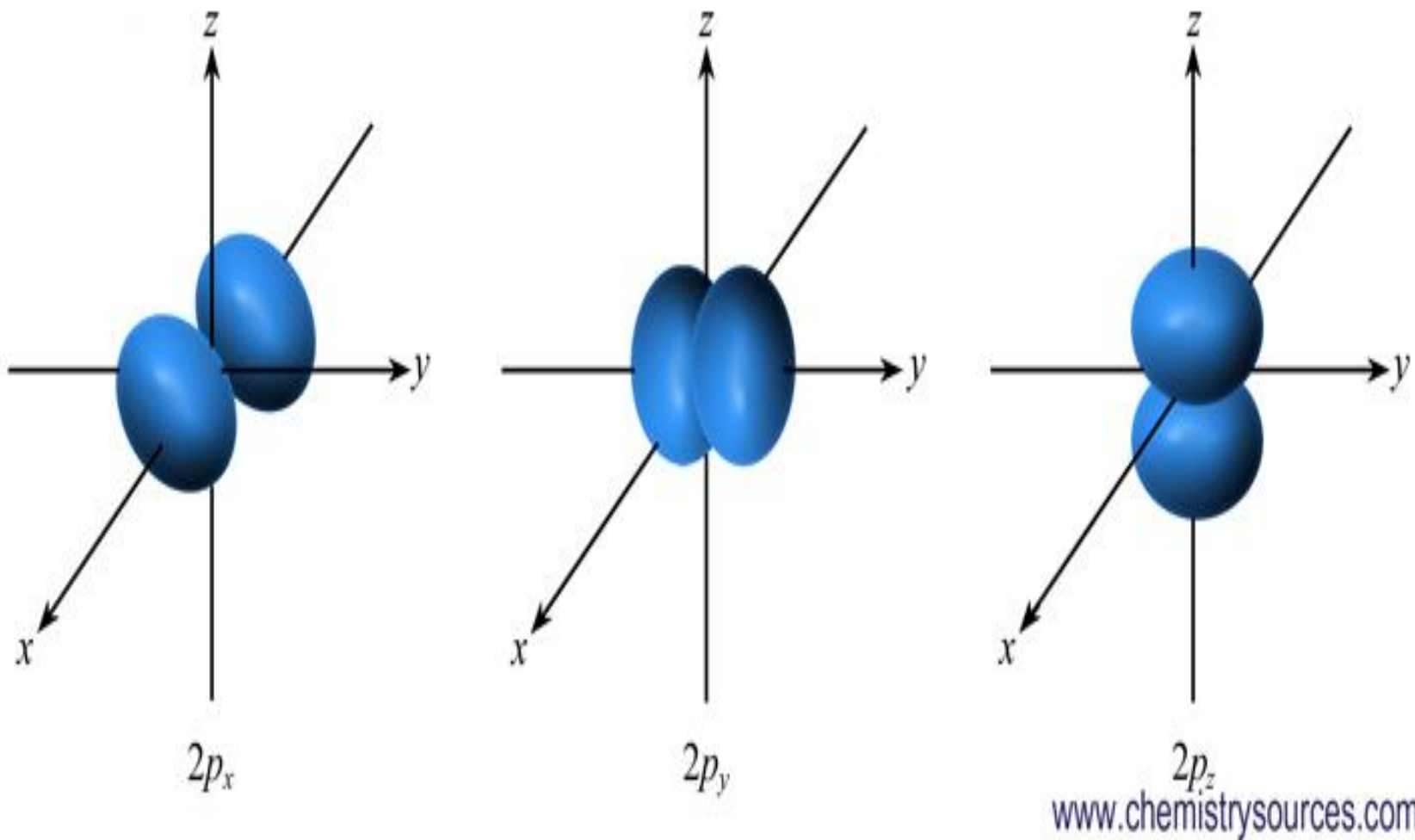

**Quantum numbers and interstitial form of rotations:****4. Spindle quantum number (s):**

- ✓ It is a number that determines the type of spindle movement of an electron around its axis.
- ✓ Every electron has two movements: the first around the nucleus ... and the second around itself and is called the spindle movement.
- ✓ The spindle movement of one of the two electrons is counter to the movement of the other electron, which reduces the repulsive forces between them.
- ✓ The quantum number has two values:  $-1/2$ ,  $+1/2$

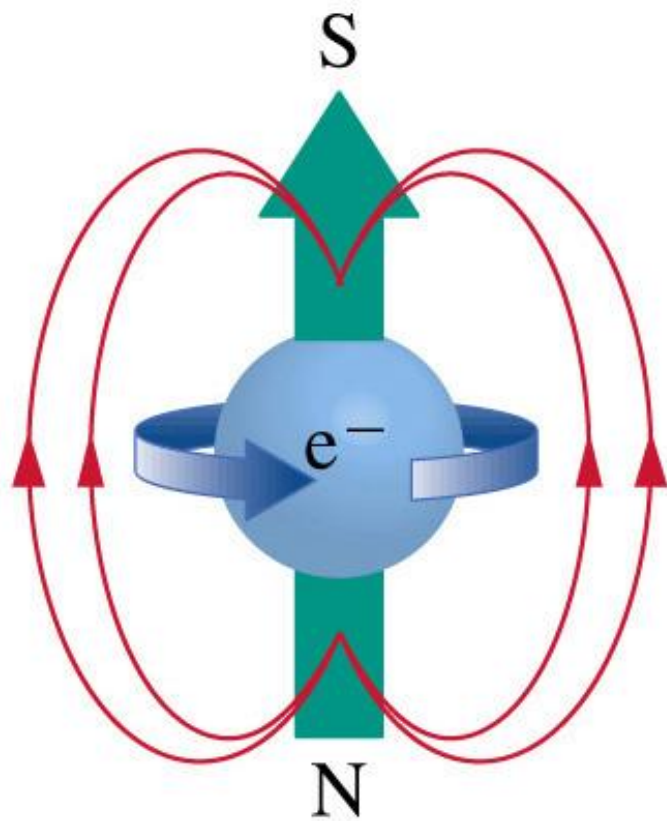
**Quantum numbers and interstitial form of rotations:****4. Spindle quantum number (s)**

$$m_s = +\frac{1}{2}$$

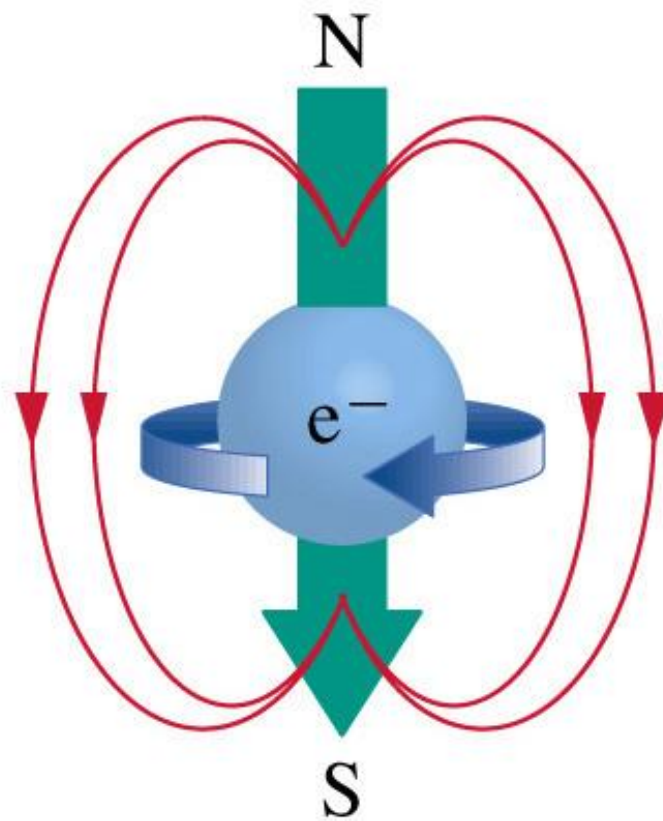

$$m_s = -\frac{1}{2}$$

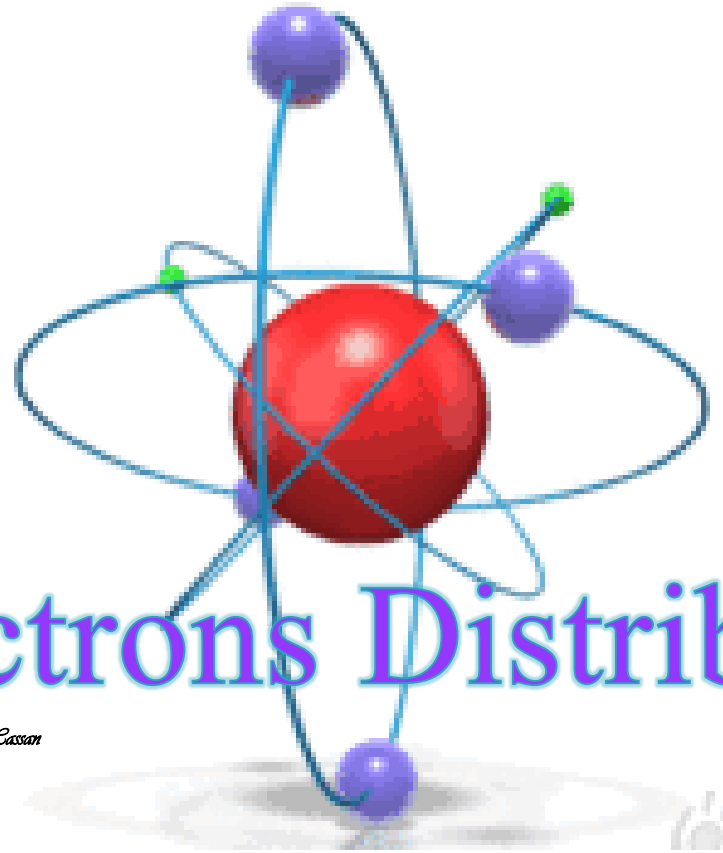

# Electrons Distribution

*Dr. Ibrahim A. I. Hassan*



## The probability distribution of electrons in an atom:

### 1. Principle of construction upward:

Electrons fill the lower-energy levels first, then the higher-energy levels.

*For example:*

$^{30}\text{Zn}$

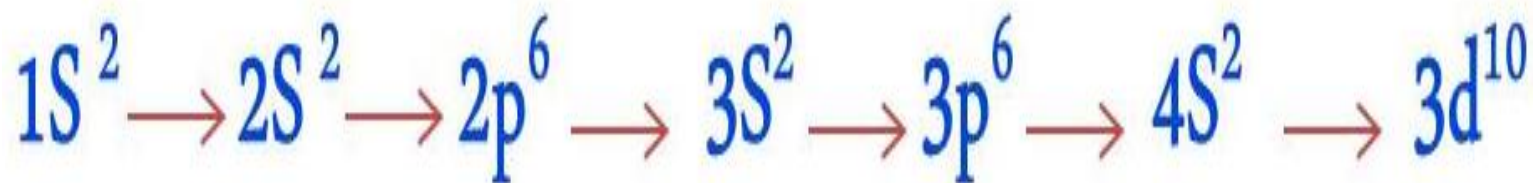

## The probability distribution of electrons in an atom:

### 2. Hund's rule:

At a certain sublevel, duplication does not occur between two electrons until their individual orbitals are operated first.

**The probability distribution of electrons in an atom:**

1. Principle of construction upward:
2. Hund's rule:

**Example:  ${}^7\text{N}$**

Principle of construction upward:-  $1s^2 2s^2 2p^3$

**Hund's rule:**

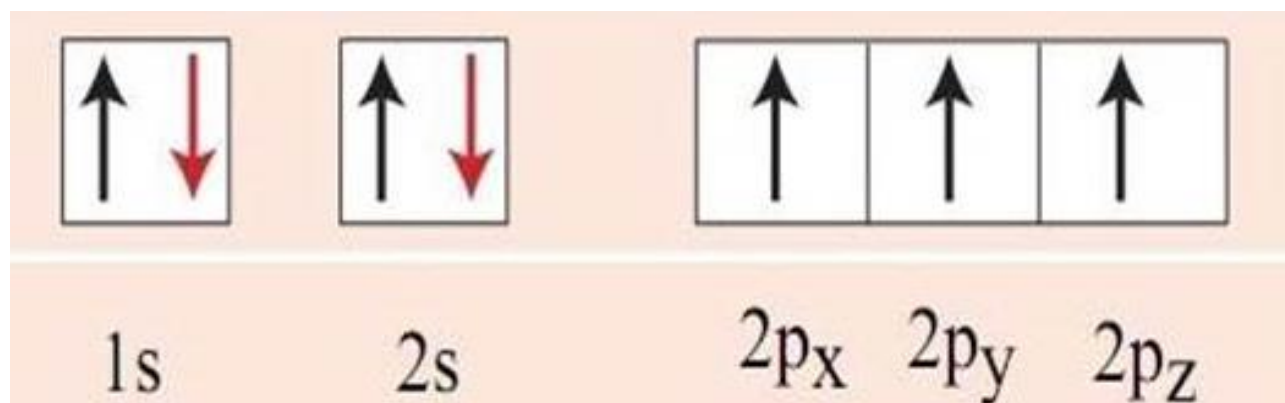

**The probability distribution of electrons in an atom:**

**Hund's rule:**

**Example:**

**$^8\text{O}$  Oxygen**

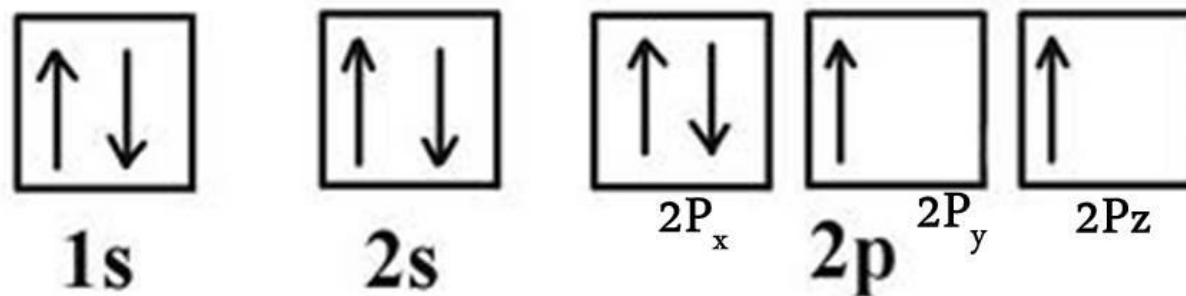

# The probability distribution of electrons in an atom

## 1. Principle of construction upward

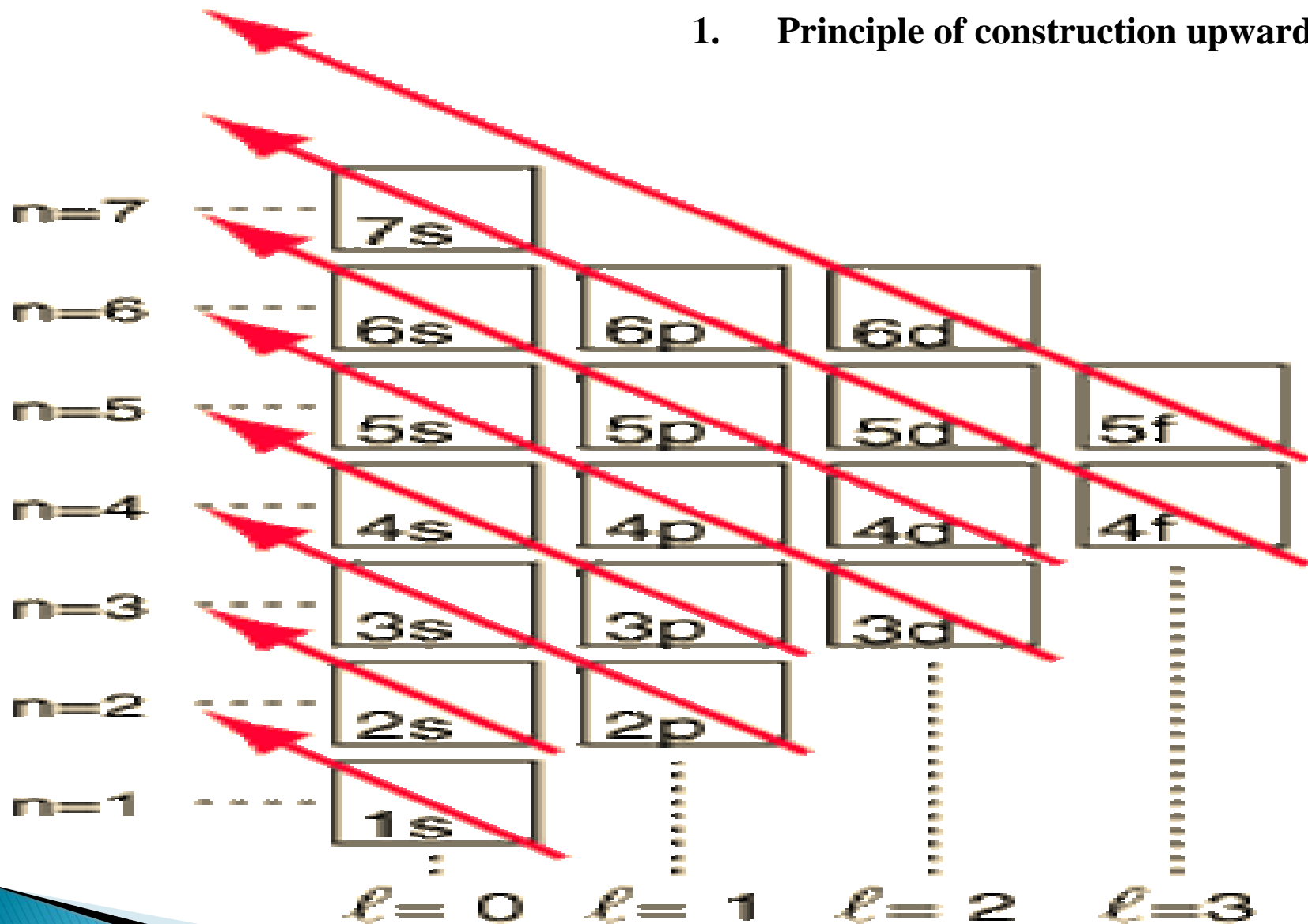

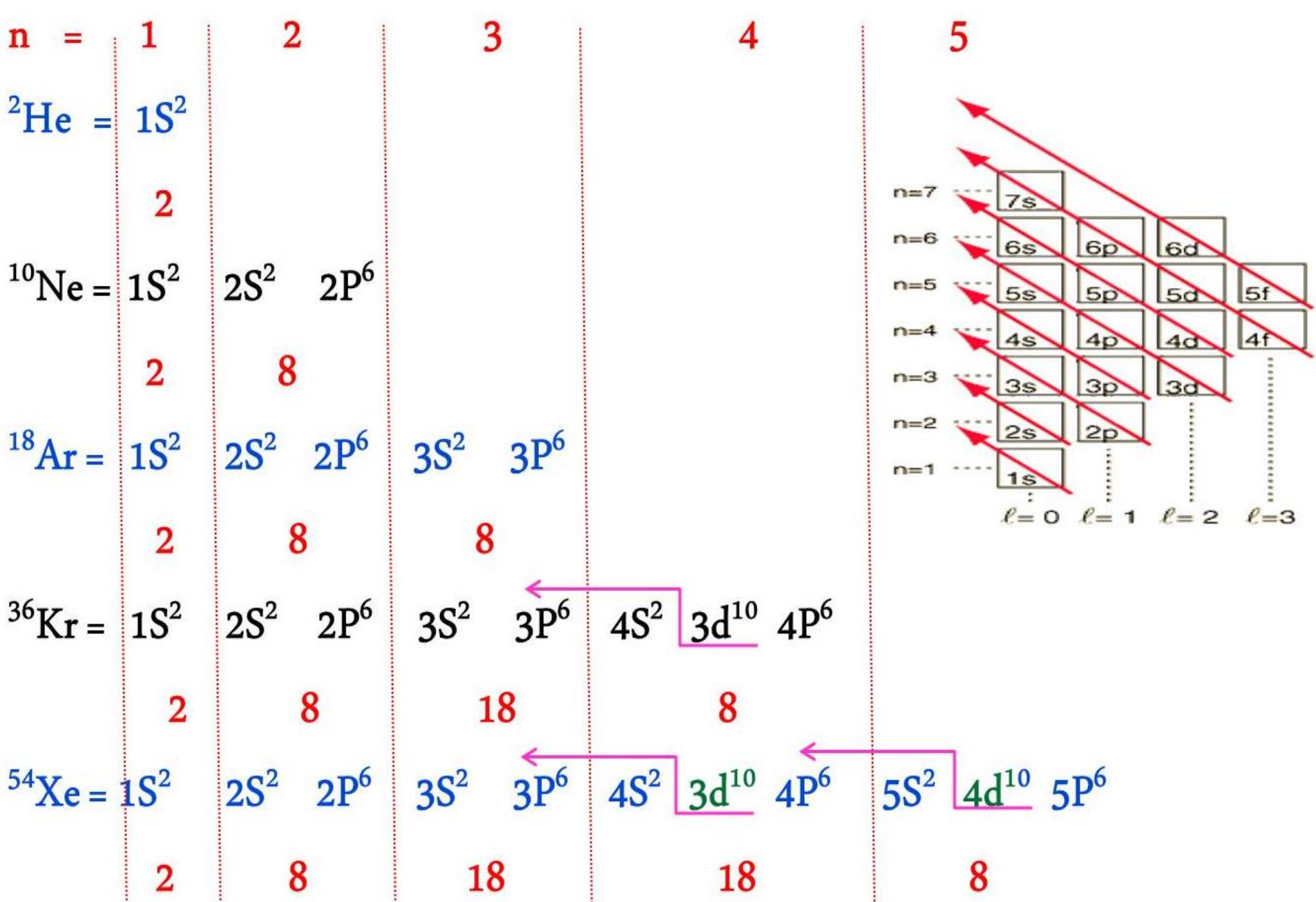



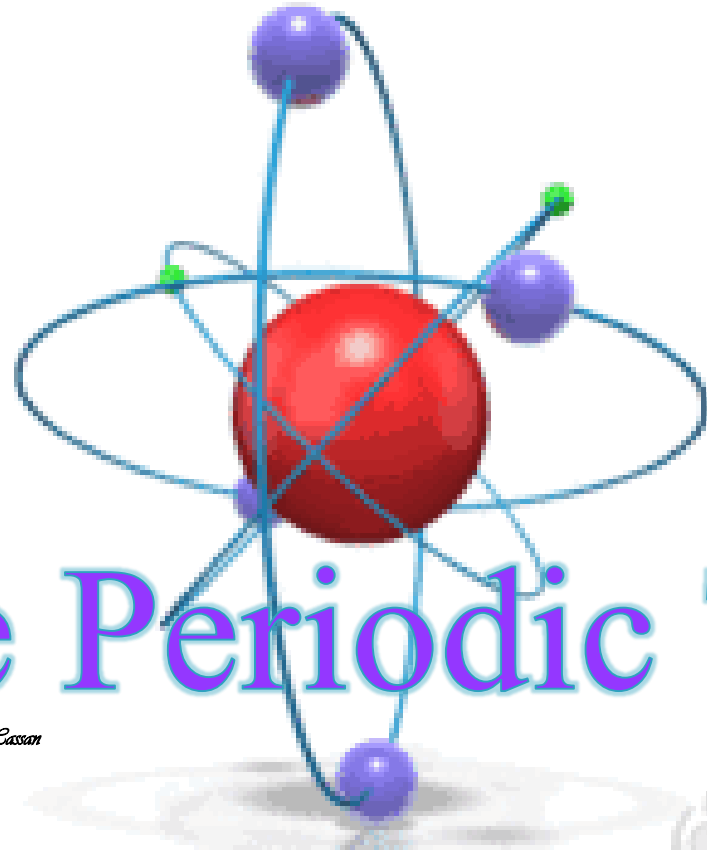

# The Periodic Table

*Dr. Ibrahim A. I. Hassan*

# The Periodic Table

1 H																	2 He
3 Li	4 Be											5 B	6 C	7 N	8 O	9 F	10 Ne
11 Na	12 Mg											13 Al	14 Si	15 P	16 S	17 Cl	18 Ar
19 K	20 Ca	21 Sc	22 Ti	23 V	24 Cr	25 Mn	26 Fe	27 Co	28 Ni	29 Cu	30 Zn	31 Ga	32 Ge	33 As	34 Se	35 Br	36 Kr
37 Rb	38 Sr	39 Y	40 Zr	41 Nb	42 Mo	43 Tc	44 Ru	45 Rh	46 Pd	47 Ag	48 Cd	49 In	50 Sn	51 Sb	52 Te	53 I	54 Xe
55 Cs	56 Ba	57-71	72 Hf	73 Ta	74 W	75 Re	76 Os	77 Ir	78 Pt	79 Au	80 Hg	81 Tl	82 Pb	83 Bi	84 Po	85 At	86 Rn
87 Fr	88 Ra	89-103	104 Rf	105 Db	106 Sg	107 Bh	108 Hs	109 Mt	110 Ds	111 Rg	112 Cn	113 Uut	114 Fl	115 Uup	116 Lv	117 Uus	118 Uuo
			57 La	58 Ce	59 Pr	60 Nd	61 Pm	62 Sm	63 Eu	64 Gd	65 Tb	66 Dy	67 Ho	68 Er	69 Tm	70 Yb	71 Lu
			89 Ac	90 Th	91 Pa	92 U	93 Np	94 Pu	95 Am	96 Cm	97 Bk	98 Cf	99 Es	100 Fm	101 Md	102 No	103 Lr

# The Periodic Table and the Properties of the Elements

- **The elements are arranged within a table so that each element exceeds the one preceding it with a single electron.**
- **This table was called the Periodic Table of the Elements.**
- **In the Periodic Table of Elements, the chemical properties of the elements of one group are similar.**

## The Periodic Table and the Properties of the Elements

According to the electronic distribution and the number of electrons in the outer orbit, known as the valence shell, the elements were divided into four groups:

### 1. **Group or block S:**

Includes hydrogen, alkaloid group, and alkaloid earths, where outer electron level begins with filling the S orbital and ends with its completion.

**2. Group or block p:**

**In which the electron begins entering the p-level and ends with its completion in the inert gas.**

**3. Group or block d:**

**It is the set of elements in which the d orbital is filled, and it is called the transition elements, and there are three groups of them:**

## The Periodic Table and the Properties of the Elements

3. **Group or block d:**
  - A. **The first series of transition elements; in which the 3d full-level sublevel continues.**
  - B. **The second transitional chain of elements; in which the 4d sublevel is sequentially filled.**
  - C. **The third transition chain of elements; in which the 5d sublevel is sequentially filled.**



**4. Group or f block:**

**It includes the elements in which the f block is filled, and these elements are known as rare-earth elements and have the characteristics of the transition elements, and the f-orbital in these elements is not completely filled.**

- a) The series of Lanthanides with which the 4f block is filled.**
- b) The chain of Actinides in which the 5f block is filled.**

# The Periodic Table

1 H																	2 He
3 Li	4 Be											5 B	6 C	7 N	8 O	9 F	10 Ne
11 Na	12 Mg											13 Al	14 Si	15 P	16 S	17 Cl	18 Ar
19 K	20 Ca	21 Sc	22 Ti	23 V	24 Cr	25 Mn	26 Fe	27 Co	28 Ni	29 Cu	30 Zn	31 Ga	32 Ge	33 As	34 Se	35 Br	36 Kr
37 Rb	38 Sr	39 Y	40 Zr	41 Nb	42 Mo	43 Tc	44 Ru	45 Rh	46 Pd	47 Ag	48 Cd	49 In	50 Sn	51 Sb	52 Te	53 I	54 Xe
55 Cs	56 Ba	57-71	72 Hf	73 Ta	74 W	75 Re	76 Os	77 Ir	78 Pt	79 Au	80 Hg	81 Tl	82 Pb	83 Bi	84 Po	85 At	86 Rn
87 Fr	88 Ra	89-103	104 Rf	105 Db	106 Sg	107 Bh	108 Hs	109 Mt	110 Ds	111 Rg	112 Cn	113 Uut	114 Fl	115 Uup	116 Lv	117 Uus	118 Uuo
			57 La	58 Ce	59 Pr	60 Nd	61 Pm	62 Sm	63 Eu	64 Gd	65 Tb	66 Dy	67 Ho	68 Er	69 Tm	70 Yb	71 Lu
			89 Ac	90 Th	91 Pa	92 U	93 Np	94 Pu	95 Am	96 Cm	97 Bk	98 Cf	99 Es	100 Fm	101 Md	102 No	103 Lr

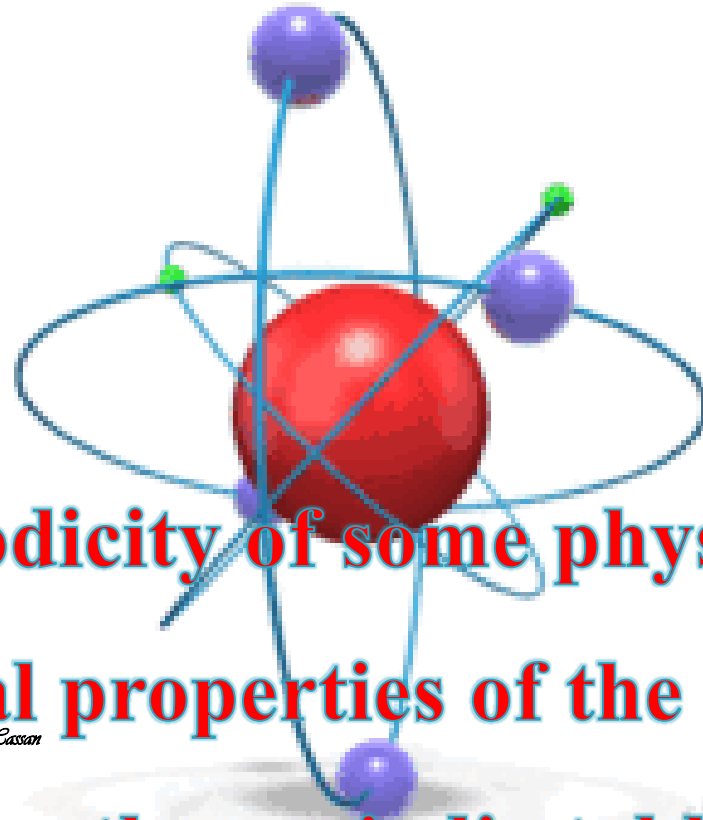

**Periodicity of some physical and  
chemical properties of the elements of  
the periodic table**

*Dr. Ibrahim A. I. Hassan*

# The Periodic Table

1 H																	2 He
3 Li	4 Be											5 B	6 C	7 N	8 O	9 F	10 Ne
11 Na	12 Mg											13 Al	14 Si	15 P	16 S	17 Cl	18 Ar
19 K	20 Ca	21 Sc	22 Ti	23 V	24 Cr	25 Mn	26 Fe	27 Co	28 Ni	29 Cu	30 Zn	31 Ga	32 Ge	33 As	34 Se	35 Br	36 Kr
37 Rb	38 Sr	39 Y	40 Zr	41 Nb	42 Mo	43 Tc	44 Ru	45 Rh	46 Pd	47 Ag	48 Cd	49 In	50 Sn	51 Sb	52 Te	53 I	54 Xe
55 Cs	56 Ba	57-71	72 Hf	73 Ta	74 W	75 Re	76 Os	77 Ir	78 Pt	79 Au	80 Hg	81 Tl	82 Pb	83 Bi	84 Po	85 At	86 Rn
87 Fr	88 Ra	89-103	104 Rf	105 Db	106 Sg	107 Bh	108 Hs	109 Mt	110 Ds	111 Rg	112 Cn	113 Uut	114 Fl	115 Uup	116 Lv	117 Uus	118 Uuo
			57 La	58 Ce	59 Pr	60 Nd	61 Pm	62 Sm	63 Eu	64 Gd	65 Tb	66 Dy	67 Ho	68 Er	69 Tm	70 Yb	71 Lu
			89 Ac	90 Th	91 Pa	92 U	93 Np	94 Pu	95 Am	96 Cm	97 Bk	98 Cf	99 Es	100 Fm	101 Md	102 No	103 Lr

## Periodicity of some physical and chemical properties of the elements of the periodic tables

- **Elements** of the same group are similar in properties because they have the same number of electrons in the outer orbital responsible for the chemical properties of the element.
- **Atomic size (radius of the atom) = half the distance between the centers of two identical atoms in a diatomic molecule.**

## **Periodicity of some physical and chemical properties of the elements of the periodic table**

### **In horizontal cycles:**

- **The atomic size decreases as we move from left to right, due to the gradual increase in the positive nucleus charge in this direction, which leads to the attraction of electrons.**

### **In vertical groups:**

- **The size of the atom increases as we go from top to bottom due to the increase in the number of energy levels and the increase in repulsion between electrons.**



	IA	IIA	IIIA	IVA	VA	VIA	VII	VIIIA
الدورة الأولى								
الدورة الثانية								
الدورة الثالثة								
الدورة الرابعة								
الدورة الخامسة								
الدورة السادسة								

## **Periodicity of some physical and chemical properties of the elements of the periodic table**

### **Electronegativity:**

**It is the ability of an atom to attract electrons in a chemical bond.**

### **In horizontal cycles:**

- ✓ **The electronegativity increases from left to right due to increase the atomic number and decreasing the radius within one cycle, which leads to an increase in the proximity of the valence electrons to the influence of the nucleus.**

## **Periodicity of some physical and chemical properties of the elements of the periodic table**

### **Electronegativity:**

#### **In vertical groups:**

- ✓ **The electronegativity decreases as we go from top to bottom due to the increase in the size of the atom, which leads to the valence electrons being gradually farther away from the influence of the nucleus.**

## Periodicity of some physical and chemical properties of the elements of the periodic table

**TABLE 1.3 The Electronegativities of Selected Elements<sup>a</sup>**

IA	IIA	IB	IIB	IIIA	IVA	VA	VIA	VIIA
H 2.1								
Li 1.0	Be 1.5			B 2.0	C 2.5	N 3.0	O 3.5	F 4.0
Na 0.9	Mg 1.2			Al 1.5	Si 1.8	P 2.1	S 2.5	Cl 3.0
K 0.8	Ca 1.0							Br 2.8
								I 2.5

increasing electronegativity

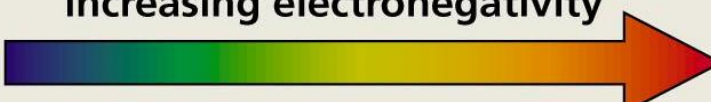

increasing electronegativity



<sup>a</sup>Electronegativity values are relative, not absolute. As a result, there are several scales of electronegativities. The electronegativities listed here are from the scale devised by Linus Pauling.

## **Ionization potential:**

**It is the amount of energy needed to remove the least bound electrons from the nucleus.**

- There is an inverse proportion between ionization potential and atomic size.**

## **In horizontal cycles:**

**The ionization potential increases from left to right due to a decrease in the radius within one cycle, which leads to an increase in the proximity of the valence electrons to the nucleus, making them difficult to extract.**

## **Periodicity of some physical and chemical properties of the elements of the periodic table**

### **Ionization potential:**

#### **In vertical groups:**

**The ionization potential decreases as we go from top to bottom due to the increase in the number of electron shells and the increase in the size of the atom, which leads to the valence electrons being gradually farther away from the effect of the nucleus, and it is easier to remove them.**



## Periodicity of some physical and chemical properties of the elements of the periodic table

### The metallic and non-metallic property

**Metals:** They are the elements whose valence shell is filled with less than half of its capacity with electrons and tend to lose valence electrons (they have a high reductive ability) in order to reach the inert gas composition.

- It conducts electricity due to the easy transfer of valence electrons.

## Periodicity of some physical and chemical properties of the elements of the periodic table

### The metallic and non-metallic property

**Nonmetals:** They are the elements whose valence shell is filled with more than half of its capacity with electrons and tend to acquire electrons ( strong oxidizing agent) in order to reach the inert gas structure.

- Electrically insulating due to the difficulty of electron transmission.

## Periodicity of some physical and chemical properties of the elements of the periodic table

### The metallic and non-metallic property

#### In horizontal cycles:

- **The metallic property decreases from left to right due to the increase the ionization potential.**
- **The cycles start with the strongest metals in the first group, then the metals decrease until the semi-metals, then the non-metals begin until we reach the strongest in the seventh group.**

## **Periodicity of some physical and chemical properties of the elements of the periodic table**

### **The metallic and non-metallic property**

#### **In the vertical groups:**

**The metallic property increases as we go from top to bottom due to the decrease in the ionization potential due to the increase in the number of electronic shells and the increase in the size of the atom, which leads to the valence electrons being gradually removed from the influence of the nucleus and it is easy to lose them.**

أشبه الهلزاة

العناصر الإنتقالية

1A	1	H	2A	3A	4A	5A	6A	7A	8A											
1	1	H Hydrogen 1.0	2	He Helium 4.0																
2	3	Li Lithium 6.9	4	Be Beryllium 9.0	5	6	7	8	9	10										
2	3	Li	4	Be	5	6	7	8	9	10										
3	11	Na Sodium 23.0	12	Mg Magnesium 24.3	13	14	15	16	17	18										
3	11	Na	12	Mg	13	14	15	16	17	18										
4	19	K Potassium 39.1	20	Ca Calcium 40.1	21	22	23	24	25	26	27	28	29	30	31	32	33	34	35	36
4	19	K	20	Ca	21	22	23	24	25	26	27	28	29	30	31	32	33	34	35	36
5	37	Rb Rubidium 85.5	38	Sr Strontium 87.6	39	40	41	42	43	44	45	46	47	48	49	50	51	52	53	54
5	37	Rb	38	Sr	39	40	41	42	43	44	45	46	47	48	49	50	51	52	53	54
6	55	Cs Caesium 132.9	56	Ba Barium 137.4	57	58	59	60	61	62	63	64	65	66	67	68	69	70	71	72
6	55	Cs	56	Ba	57	58	59	60	61	62	63	64	65	66	67	68	69	70	71	72
7	87	Fr Francium 223.0	88	Ra Radium 226.0	89	90	91	92	93	94	95	96	97	98	99	100	101	102	103	
7	87	Fr	88	Ra	89	90	91	92	93	94	95	96	97	98	99	100	101	102	103	

الهلزاة ← → الأهلزاة

العناصر الإنتقالية الداخلية

58	59	60	61	62	63	64	65	66	67	68	69	70	71
Ce Cerium 140.1	Pr Praseodymium 140.9	Nd Neodymium 144.2	Pm Promethium 147.0	Sm Samarium 150.4	Eu Europium 152.0	Gd Gadolinium 157.3	Tb Terbium 158.9	Dy Dysprosium 162.5	Ho Holmium 164.9	Er Erbium 167.3	Tm Thulium 168.9	Yb Ytterbium 173.0	Lu Lutetium 175.0
90	91	92	93	94	95	96	97	98	99	100	101	102	103
Th Thorium 232.0	Pa Protactinium 231.0	U Uranium 238.0	Np Neptunium 237.0	Pu Plutonium 242.0	Am Americium 243.0	Cm Curium 247.0	Bk Berkelium 247.0	Cf Californium 251.0	Es Einsteinium 254.0	Fm Fermium 253.0	Md Mendelevium 258.0	No Nobelium 254.0	Lr Lawrencium 257.0



# Chemical properties of different elements

## S Orbital Elements:

It includes the elements whose valence electrons fall into the S sub orbital.

### Group IA Elements (Alkali Metals):

- All of these metals have an external electron configuration of  $S^1$ .
- The valence electron has a low ionization potential and low electronegativity and the decrease of electronegativity increases from lithium to cesium.

	IA
2S	<sup>3</sup> Li
3S	<sup>11</sup> Na
4S	<sup>19</sup> K
5S	<sup>37</sup> Rb
6S	<sup>55</sup> Cs



### S Orbital Elements:

#### Group IA Elements (Alkali Metals):

- It is one of the most active metals chemically, so it does not exist in nature in the form of a metal, but as compounds with oxygen, chlorine or other elements.
- It has very strong reductive properties and has an oxidation state of +1.

	IA
2S	<sup>3</sup> Li
3S	<sup>11</sup> Na
4S	<sup>19</sup> K
5S	<sup>37</sup> Rb
6S	<sup>55</sup> Cs

## Chemical properties of different elements

### S Orbital Elements:

#### Group IA Elements (Alkali Metals):

- It reacts violently with water and releases great heat.



- Low melting and boiling points.
- Soft and easy to be re-formated.

	IA
2S	<sup>3</sup> Li
3S	<sup>11</sup> Na
4S	<sup>19</sup> K
5S	<sup>37</sup> Rb
6S	<sup>55</sup> Cs

## Chemical properties of different elements

### S Orbital Elements:

#### Group IA Elements (Alkali Metals):

- **Its compounds are easily soluble in water.**
- **Solutions of the compounds of these metals are colorless, because their ions do not contain free electrons that can be transferred from their energy level to a higher energy level in the visible radiation region.**

IA	
2S	<sup>3</sup> Li
3S	<sup>11</sup> Na
4S	<sup>19</sup> K
5S	<sup>37</sup> Rb
6S	<sup>55</sup> Cs

## Chemical properties of different elements

### S Orbital Elements:

### Group IIA elements (alkaline earth metals):

- All of these alkaline earth metals have an external electron structure of  $S^2$ .
- Their electrons have a low ionization potential and low electronegativity, but they are higher than those of the alkali metals.
- It has a high reducing power but it is lower than the alkali metals.

IIA	
2S	<sup>4</sup> Be
3S	<sup>12</sup> Mg
4S	<sup>20</sup> Ca
5S	<sup>38</sup> Sr
6S	<sup>56</sup> Ba

## Chemical properties of different elements

### S Orbital Elements:

### Group IIA elements (alkaline earth metals):

- It does not exist in a pure state due to its chemical activity.
- Its melting and boiling points are higher than the alkali metals.
- Harder than IA metals.

IIA	
2S	<sup>4</sup> Be
3S	<sup>12</sup> Mg
4S	<sup>20</sup> Ca
5S	<sup>38</sup> Sr
6S	<sup>56</sup> Ba

## Chemical properties of different elements

### P orbital elements

- All of these elements have the external electronic configuration  $P^{1-6}$ .
- Its elements are characterized by sharp changes within the same group, when moving from metallic properties to non-metallic properties.

	III A	IV A	V A	VIA	VII A
2P	<sup>5</sup> B	<sup>6</sup> C	<sup>7</sup> N	<sup>8</sup> O	<sup>9</sup> F
3P	<sup>13</sup> Al	<sup>14</sup> Si	<sup>15</sup> P	<sup>16</sup> S	<sup>17</sup> Cl
4P	<sup>31</sup> Ga	<sup>32</sup> Ge	<sup>33</sup> As	<sup>34</sup> Se	<sup>35</sup> Br
5P	<sup>49</sup> In	<sup>50</sup> Sn	<sup>51</sup> Sb	<sup>52</sup> Te	<sup>53</sup> I
6P	<sup>81</sup> Tl	<sup>82</sup> Pb	<sup>83</sup> Bi	<sup>84</sup> Po	<sup>85</sup> At



## Chemical properties of different elements

### P orbital elements

- Group III A are all metals, except boron, which is non-metal.

	III A	IV A	V A	VIA	VII A
2P	<sup>5</sup> B	<sup>6</sup> C	<sup>7</sup> N	<sup>8</sup> O	<sup>9</sup> F
3P	<sup>13</sup> Al	<sup>14</sup> Si	<sup>15</sup> P	<sup>16</sup> S	<sup>17</sup> Cl
4P	<sup>31</sup> Ga	<sup>32</sup> Ge	<sup>33</sup> As	<sup>34</sup> Se	<sup>35</sup> Br
5P	<sup>49</sup> In	<sup>50</sup> Sn	<sup>51</sup> Sb	<sup>52</sup> Te	<sup>53</sup> I
6P	<sup>81</sup> Tl	<sup>82</sup> Pb	<sup>83</sup> Bi	<sup>84</sup> Po	<sup>85</sup> At

## Chemical properties of different elements

### P orbital elements

- In the group IV A carbon is non-metal, silicon is a non-metal with some metallic properties, germanium is a semimetal.
- Tin and lead are metals.

	III A	IV A	V A	VIA	VII A
2P	<sup>5</sup> B	<sup>6</sup> C	<sup>7</sup> N	<sup>8</sup> O	<sup>9</sup> F
3P	<sup>13</sup> Al	<sup>14</sup> Si	<sup>15</sup> P	<sup>16</sup> S	<sup>17</sup> Cl
4P	<sup>31</sup> Ga	<sup>32</sup> Ge	<sup>33</sup> As	<sup>34</sup> Se	<sup>35</sup> Br
5P	<sup>49</sup> In	<sup>50</sup> Sn	<sup>51</sup> Sb	<sup>52</sup> Te	<sup>53</sup> I
6P	<sup>81</sup> Tl	<sup>82</sup> Pb	<sup>83</sup> Bi	<sup>84</sup> Po	<sup>85</sup> At

## Chemical properties of different elements

### P orbital elements

- In group V A, the change in the properties of its elements is very similar to the change in the properties of the elements of group IV A, but the transition from a non-metallic state to a metallic state occurs at a low level in group V A.

	III A	IV A	V A	VIA	VII A
2P	<sup>5</sup> B	<sup>6</sup> C	<sup>7</sup> N	<sup>8</sup> O	<sup>9</sup> F
3P	<sup>13</sup> Al	<sup>14</sup> Si	<sup>15</sup> P	<sup>16</sup> S	<sup>17</sup> Cl
4P	<sup>31</sup> Ga	<sup>32</sup> Ge	<sup>33</sup> As	<sup>34</sup> Se	<sup>35</sup> Br
5P	<sup>49</sup> In	<sup>50</sup> Sn	<sup>51</sup> Sb	<sup>52</sup> Te	<sup>53</sup> I
6P	<sup>81</sup> Tl	<sup>82</sup> Pb	<sup>83</sup> Bi	<sup>84</sup> Po	<sup>85</sup> At

### P orbital elements

- In group V A, Nitrogen and phosphorus are considered non-metals, while arsenic and antimony are semi-metals, and bismuth is a metal.

	III A	IV A	V A	VIA	VII A
2P	<sup>5</sup> B	<sup>6</sup> C	<sup>7</sup> N	<sup>8</sup> O	<sup>9</sup> F
3P	<sup>13</sup> Al	<sup>14</sup> Si	<sup>15</sup> P	<sup>16</sup> S	<sup>17</sup> Cl
4P	<sup>31</sup> Ga	<sup>32</sup> Ge	<sup>33</sup> As	<sup>34</sup> Se	<sup>35</sup> Br
5P	<sup>49</sup> In	<sup>50</sup> Sn	<sup>51</sup> Sb	<sup>52</sup> Te	<sup>53</sup> I
6P	<sup>81</sup> Tl	<sup>82</sup> Pb	<sup>83</sup> Bi	<sup>84</sup> Po	<sup>85</sup> At

### P orbital elements

#### In group VI A,

The change in its characteristics is very similar to the change in the characteristics of group V A.

- Oxygen and sulfur are non-metals, selenium and tellurium are semi-metals, and polonium is a metal.

	III A	IV A	V A	VIA	VII A
2P	<sup>5</sup> B	<sup>6</sup> C	<sup>7</sup> N	<sup>8</sup> O	<sup>9</sup> F
3P	<sup>13</sup> Al	<sup>14</sup> Si	<sup>15</sup> P	<sup>16</sup> S	<sup>17</sup> Cl
4P	<sup>31</sup> Ga	<sup>32</sup> Ge	<sup>33</sup> As	<sup>34</sup> Se	<sup>35</sup> Br
5P	<sup>49</sup> In	<sup>50</sup> Sn	<sup>51</sup> Sb	<sup>52</sup> Te	<sup>53</sup> I
6P	<sup>81</sup> Tl	<sup>82</sup> Pb	<sup>83</sup> Bi	<sup>84</sup> Po	<sup>85</sup> At



### P orbital elements

#### In group V II A,

All of the group VII A halogens are nonmetals. Its outermost orbital contains 7 electrons and is one electron lower than its nearest inert gas, so it is easily reduced.

	III A	IVA	VA	VIA	VII A
2P	<sup>5</sup> B	<sup>6</sup> C	<sup>7</sup> N	<sup>8</sup> O	<sup>9</sup> F
3P	<sup>13</sup> Al	<sup>14</sup> Si	<sup>15</sup> P	<sup>16</sup> S	<sup>17</sup> Cl
4P	<sup>31</sup> Ga	<sup>32</sup> Ge	<sup>33</sup> As	<sup>34</sup> Se	<sup>35</sup> Br
5P	<sup>49</sup> In	<sup>50</sup> Sn	<sup>51</sup> Sb	<sup>52</sup> Te	<sup>53</sup> I
6P	<sup>81</sup> Tl	<sup>82</sup> Pb	<sup>83</sup> Bi	<sup>84</sup> Po	<sup>85</sup> At



## Orbital elements d

It is the group of elements that fill the d orbital and are called transition elements.

✓ They are all metals, they classified into three groups:

1. The first transition elements series: the 3d sub-level is filled in successively.

	3	4	5	6	7	8	9	10	11	12
3d	<sup>21</sup> Sc	<sup>22</sup> Ti	<sup>23</sup> V	<sup>24</sup> Cr	<sup>25</sup> Mn	<sup>26</sup> Fe	<sup>27</sup> Co	<sup>28</sup> Ni	<sup>29</sup> Cu	<sup>30</sup> Zn
4d	<sup>39</sup> Y	<sup>40</sup> Zr	<sup>41</sup> Nb	<sup>42</sup> Mo	<sup>43</sup> Tc	<sup>44</sup> Ru	<sup>45</sup> Rh	<sup>46</sup> Pd	<sup>47</sup> Ag	<sup>48</sup> Cd
5d	<sup>57</sup> La	<sup>72</sup> Hf	<sup>73</sup> Ta	<sup>74</sup> W	<sup>75</sup> Re	<sup>76</sup> Os	<sup>77</sup> Ir	<sup>78</sup> Pt	<sup>79</sup> Au	<sup>80</sup> Hg

## Chemical properties of different elements

### Orbital elements d

- The second transition element series, in which the 4d sublevel is filled in successively.
- The third transition element series, in which the 5d sublevel is filled in succession.

	3	4	5	6	7	8	9	10	11	12
3d	<sup>21</sup> Sc	<sup>22</sup> Ti	<sup>23</sup> V	<sup>24</sup> Cr	<sup>25</sup> Mn	<sup>26</sup> Fe	<sup>27</sup> Co	<sup>28</sup> Ni	<sup>29</sup> Cu	<sup>30</sup> Zn
4d	<sup>39</sup> Y	<sup>40</sup> Zr	<sup>41</sup> Nb	<sup>42</sup> Mo	<sup>43</sup> Tc	<sup>44</sup> Ru	<sup>45</sup> Rh	<sup>46</sup> Pd	<sup>47</sup> Ag	<sup>48</sup> Cd
5d	<sup>57</sup> La	<sup>72</sup> Hf	<sup>73</sup> Ta	<sup>74</sup> W	<sup>75</sup> Re	<sup>76</sup> Os	<sup>77</sup> Ir	<sup>78</sup> Pt	<sup>79</sup> Au	<sup>80</sup> Hg

## Chemical properties of different elements

### Orbital elements d

- ✓ Its melting and boiling points are high.
- ✓ As the atomic number increases, the atomic size within the transition cycle decreases.

	3	4	5	6	7	8	9	10	11	12
3d	<sup>21</sup> Sc	<sup>22</sup> Ti	<sup>23</sup> V	<sup>24</sup> Cr	<sup>25</sup> Mn	<sup>26</sup> Fe	<sup>27</sup> Co	<sup>28</sup> Ni	<sup>29</sup> Cu	<sup>30</sup> Zn
4d	<sup>39</sup> Y	<sup>40</sup> Zr	<sup>41</sup> Nb	<sup>42</sup> Mo	<sup>43</sup> Tc	<sup>44</sup> Ru	<sup>45</sup> Rh	<sup>46</sup> Pd	<sup>47</sup> Ag	<sup>48</sup> Cd
5d	<sup>57</sup> La	<sup>72</sup> Hf	<sup>73</sup> Ta	<sup>74</sup> W	<sup>75</sup> Re	<sup>76</sup> Os	<sup>77</sup> Ir	<sup>78</sup> Pt	<sup>79</sup> Au	<sup>80</sup> Hg

### f orbital elements:

It includes the elements in which the f-orbital is filled.

- These elements are known as rare earth elements and they have the characteristics of transitional elements.
- The f-orbital in these elements is not completely filled.

This group includes two series:

- The lanthanide series, which is filled with 4f

57 La	58 Ce	59 Pr	60 Nd	61 Pm	62 Sm	63 Eu	64 Gd	65 Tb	66 Dy	67 Ho	68 Er	69 Tm	70 Yb	71 Lu
89 Ac	90 Th	91 Pa	92 U	93 Np	94 Pu	95 Am	96 Cm	97 Bk	98 Cf	99 Es	100 Fm	101 Md	102 No	103 Lr

## Chemical properties of different elements

### f orbital elements:

- ❑ The actinide series with which the 5f cycloid is filled
- ❑ All metals are chemically active and react violently with water, releasing hydrogen.
- ❑ The chemical properties of the lanthanides are very similar.

57 La	58 Ce	59 Pr	60 Nd	61 Pm	62 Sm	63 Eu	64 Gd	65 Tb	66 Dy	67 Ho	68 Er	69 Tm	70 Yb	71 Lu
89 Ac	90 Th	91 Pa	92 U	93 Np	94 Pu	95 Am	96 Cm	97 Bk	98 Cf	99 Es	100 Fm	101 Md	102 No	103 Lr

## Chemical properties of different elements

### f orbital elements:

- They are found in nature together and are difficult to separate by normal chemical methods.
- The actinide elements differ from the lanthanides in that they are radioactive.

57 La	58 Ce	59 Pr	60 Nd	61 Pm	62 Sm	63 Eu	64 Gd	65 Tb	66 Dy	67 Ho	68 Er	69 Tm	70 Yb	71 Lu
89 Ac	90 Th	91 Pa	92 U	93 Np	94 Pu	95 Am	96 Cm	97 Bk	98 Cf	99 Es	100 Fm	101 Md	102 No	103 Lr



# The Periodic Table

1 H																	2 He
3 Li	4 Be											5 B	6 C	7 N	8 O	9 F	10 Ne
11 Na	12 Mg											13 Al	14 Si	15 P	16 S	17 Cl	18 Ar
19 K	20 Ca	21 Sc	22 Ti	23 V	24 Cr	25 Mn	26 Fe	27 Co	28 Ni	29 Cu	30 Zn	31 Ga	32 Ge	33 As	34 Se	35 Br	36 Kr
37 Rb	38 Sr	39 Y	40 Zr	41 Nb	42 Mo	43 Tc	44 Ru	45 Rh	46 Pd	47 Ag	48 Cd	49 In	50 Sn	51 Sb	52 Te	53 I	54 Xe
55 Cs	56 Ba	57-71	72 Hf	73 Ta	74 W	75 Re	76 Os	77 Ir	78 Pt	79 Au	80 Hg	81 Tl	82 Pb	83 Bi	84 Po	85 At	86 Rn
87 Fr	88 Ra	89-103	104 Rf	105 Db	106 Sg	107 Bh	108 Hs	109 Mt	110 Ds	111 Rg	112 Cn	113 Uut	114 Fl	115 Uup	116 Lv	117 Uus	118 Uuo
			57 La	58 Ce	59 Pr	60 Nd	61 Pm	62 Sm	63 Eu	64 Gd	65 Tb	66 Dy	67 Ho	68 Er	69 Tm	70 Yb	71 Lu
			89 Ac	90 Th	91 Pa	92 U	93 Np	94 Pu	95 Am	96 Cm	97 Bk	98 Cf	99 Es	100 Fm	101 Md	102 No	103 Lr

1A																	8A	
1	2											2						
1	H																	He
	Hydrogen																	Helium
	1.0																	4.0
2	3	4											5	6	7	8	9	10
2	Li	Be											B	C	N	O	F	Ne
	Lithium	Beryllium											Boron	Carbon	Nitrogen	Oxygen	Fluorine	Neon
	6.9	9.0											10.8	12.0	14.0	16.0	19.0	20.2
3	11	12											13	14	15	16	17	18
3	Na	Mg											Al	Si	P	S	Cl	Ar
	Sodium	Magnesium											Aluminum	Silicon	Phosphorus	Sulfur	Chlorine	Argon
	23.0	24.3											27.0	28.1	31.0	32.1	35.5	40.0
4	19	20	21	22	23	24	25	26	27	28	29	30	31	32	33	34	35	36
4	K	Ca	Sc	Ti	V	Cr	Mn	Fe	Co	Ni	Cu	Zn	Ga	Ge	As	Se	Br	Kr
	Potassium	Calcium	Scandium	Titanium	Vanadium	Chromium	Manganese	Iron	Cobalt	Nickel	Copper	Zinc	Gallium	Germanium	Arsenic	Selenium	Bromine	Krypton
	39.1	40.2	45.0	47.9	50.9	52.0	54.9	55.8	58.9	58.7	63.5	65.4	69.7	72.6	74.9	79.0	79.9	83.8
5	37	38	39	40	41	42	43	44	45	46	47	48	49	50	51	52	53	54
5	Rb	Sr	Y	Zr	Nb	Mo	Tc	Ru	Rh	Pd	Ag	Cd	In	Sn	Sb	Te	I	Xe
	Rubidium	Strontium	Yttrium	Zirconium	Niobium	Molybdenum	Technetium	Ruthenium	Rhodium	Palladium	Silver	Cadmium	Indium	Tin	Antimony	Tellurium	Iodine	Xenon
	85.5	87.6	88.9	91.2	92.9	95.9	98	101.0	102.9	106.4	107.9	112.4	114.8	118.7	121.8	127.6	126.9	131.3
6	55	56	57	72	73	74	75	76	77	78	79	80	81	82	83	84	85	86
6	Cs	Ba	La	Hf	Ta	W	Re	Os	Ir	Pt	Au	Hg	Tl	Pb	Bi	Po	At	Rn
	Caesium	Barium	Lanthanum	Hafnium	Tantalum	Tungsten	Rhenium	Osmium	Iridium	Platinum	Gold	Mercury	Thallium	Lead	Bismuth	Polonium	Astatine	Radon
	132.9	137.4	138.9	178.5	181.0	183.9	186.2	190.2	192.2	195.1	197.0	200.6	204.4	207.2	209.0	210.0	210.0	222.0
7	87	88	89	104	105	106	107	108	109	110								
7	Fr	Ra	Ac	Rf	Db	Sg	Bh	Hs	Mt	Uun								
	Francium	Radium	Actinium	Rutherfordium	Dubnium	Seaborgium	Bohrium	Hassium	Mitrium	Ununilium								
	223.0	226.0	227.0	261	262	263	262	265	266	272								

أشبه الهلزات

العناصر الإنتقالية

الهلزات

الأولزات

العناصر الإنتقالية الداخلية

58	59	60	61	62	63	64	65	66	67	68	69	70	71
Ce	Pr	Nd	Pm	Sm	Eu	Gd	Tb	Dy	Ho	Er	Tm	Yb	Lu
Cerium	Praseodymium	Neodymium	Promethium	Samarium	Europium	Gadolinium	Terbium	Dysprosium	Holmium	Erbium	Thulium	Ytterbium	Lutetium
140.1	140.9	145.2	147.0	150.4	152.0	157.3	158.9	162.5	164.9	167.3	168.9	173.0	175.0
90	91	92	93	94	95	96	97	98	99	100	101	102	103
Th	Pa	U	Np	Pu	Am	Cm	Bk	Cf	Es	Fm	Md	No	Lr
Thorium	Protactinium	Uranium	Neptunium	Plutonium	Americium	Curium	Berkelium	Californium	Einsteinium	Fermium	Mendelevium	Nobelium	Lawrencium
232.0	231.0	238.0	237.0	242.0	243.0	247.0	247.0	251.0	254.0	253.0	258.0	259.0	260.0

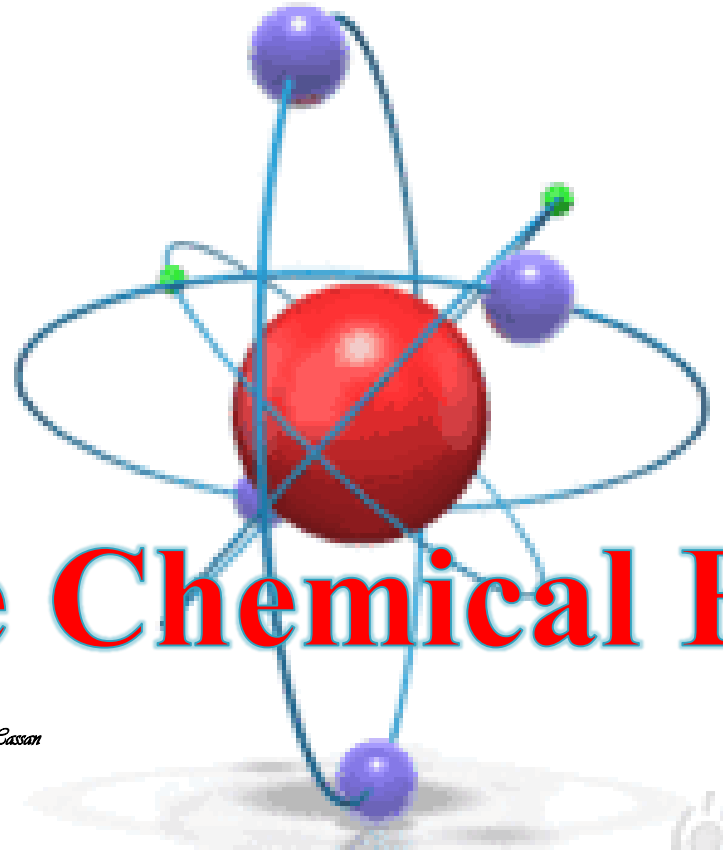

# The Chemical Bonds

*Dr. Ibrahim A. I. Hassan*

# Chemical bonds

**Chemical elements enter into chemical reactions so that their composition becomes similar to the electronic composition of the nearest inert gas by losing, gaining or sharing electrons, which leads to the formation of chemical bonds.**

# Chemical bonds

## Types of Chemical bonds

### I. Ionic bond:

- It arises as a result of the transfer of electrons from one atom to another as a result of the tendency of one of them to lose electrons and the tendency of the other to gain electrons so that both of them reach in their outer orbital an electronic arrangement similar to the near inert gas.



# Chemical bonds

## I. Ionic bond:

- ❑ The first atom turns into a positive ion and the other into a negative ion, attraction occurs between them, ionic bonds are formed, and ionic compounds are formed.
- ❑ Ionic bond found in acids, bases and salts.

**HCl, CH<sub>3</sub>COOH, NaOH, Ca(OH)<sub>2</sub>, NaCl, CaSO<sub>4</sub>**



## Chemical bonds

### I. Ionic bond:

- A single ionic bond as in sodium chloride.

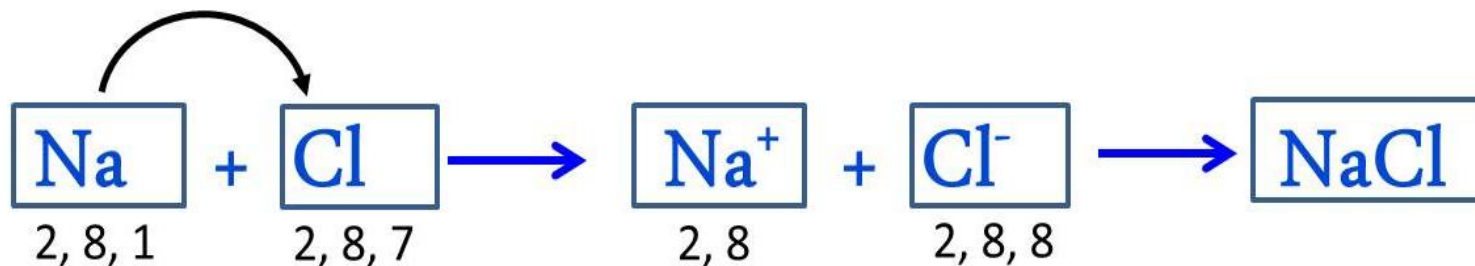

- A double ionic bond, as in the case of magnesium chloride.

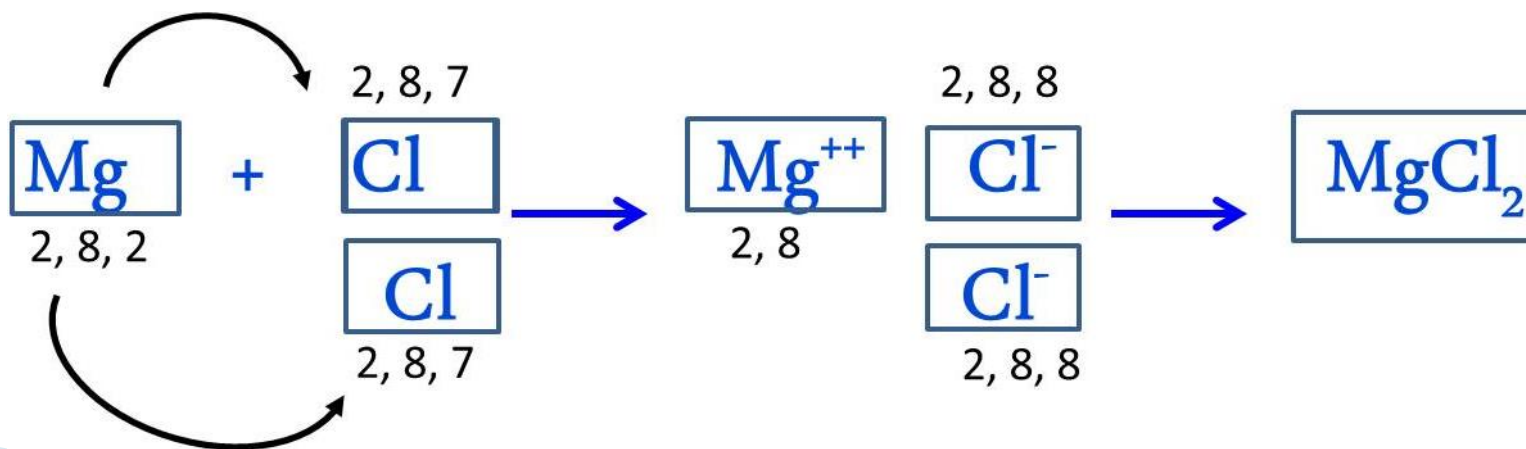

## Chemical bonds

### I. Ionic bond:

## Common properties of ionic compounds:

1. **The bond between ions of different charge is electrostatic attraction, as it does not have a specific direction in the vacuum.**
2. **In solid compounds, the molecules are closely attached and do not evaporate, and their melting and boiling points are very high.**
3. **When ionic compounds dissolve or melt, they disintegrate into ions that conduct electricity.**

### Common properties of ionic compounds:

4. Ionic compounds are soluble in polar solvents such as water and insoluble in organic solvents (non-polar).
5. Ions in ionic compounds are not considered stable or rigid systems. Under the influence of an electric field, the electrons and nuclei of these ions move in opposite directions (polarization).

### II. Covalent Bond:

A bond in which each atom contributes an electron.

#### Theories to Explain Covalent Bonds:

##### i. The Valence Electronic Theory to Explain Covalent Bonds:

- The atoms equivalent to each other, and each atom contributes a number of electrons (valence electrons - sharing electrons) to reach the electronic distribution of the nearest inert gas.

## Chemical bonds

### II. Covalent Bond:

- The bond is represented by a line (-).

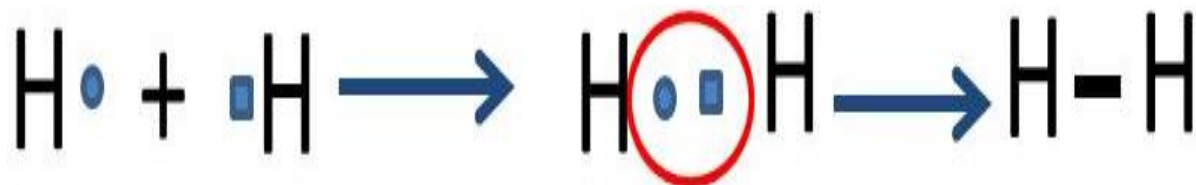

- It may form between two identical atoms.

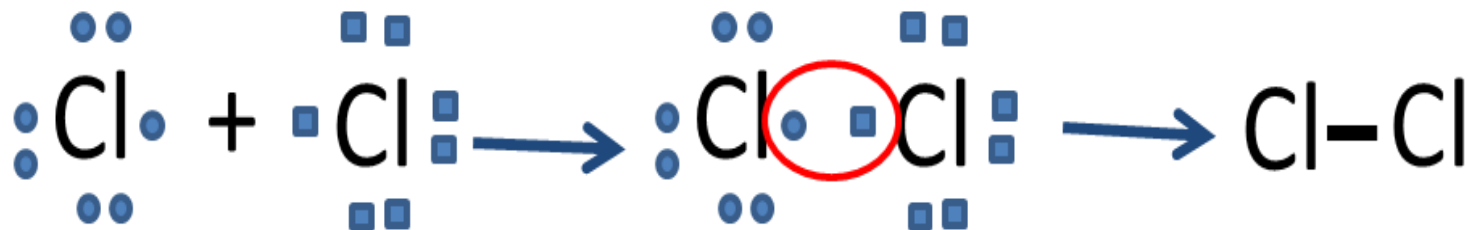

- The resulting molecule is not ionized.

## Chemical bonds

### II. Covalent bond

- An atom may share more than one electron.

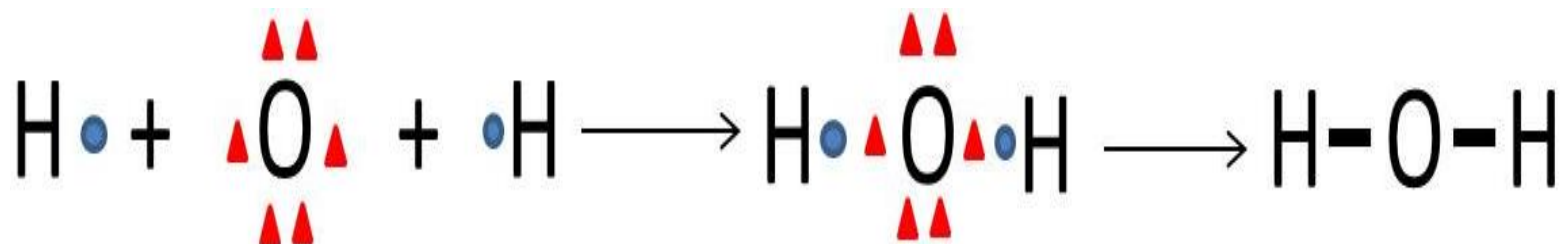



## Chemical bonds

### Theories to Explain Covalent Bonds:

#### ii. Valence bond theory to explain covalent bonds:

A covalent bond is formed when the individual atoms come close to each other, and then an interference occurs between the orbital of one of the two atoms, which contains a single electron, with the orbital of another atom that has a single electron.

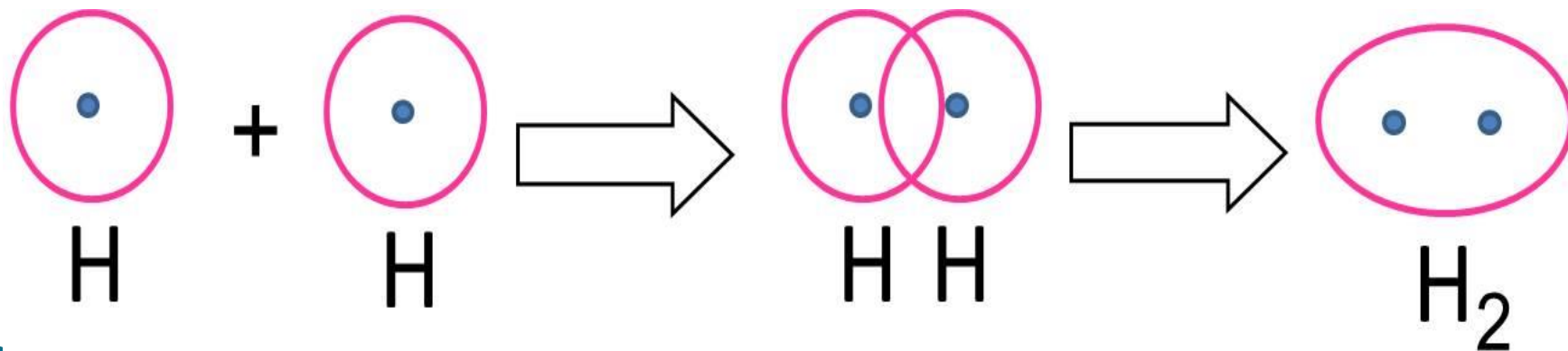

### Characteristics of Covalent Compounds:

1. **Covalent bonds have a definite orientation in space.**
2. **Atoms bond to each other by electrons, not by electrostatic attraction.**
3. **Atoms cannot be separated from each other without chemical dissociation, neither do they disintegrate in water, nor do they conduct electricity.**
4. **Covalent compounds have low melting and boiling points.**
5. **Covalent compounds do not dissolve in water (polar) but dissolve in organic compounds (non-polar).**

### III. Coordinating bond:

- ❖ **One of the two atoms donates a pair of electrons (donor atom) to the other atom (receiver atom) without losing it completely and without the other atom contributing. The electronic structure is consistent in the two united atoms.**
- ❖ **In the coordinating bond; The donor atom has an octet having a pair of electrons and the receiving atom needs a pair of electrons to reach the inactive or stable octet.**
- ❖ **The coordinating bond is represented by an arrow pointing from the donor atom to the acceptor atom.**

## Chemical bonds

- ❖ An example of a coordination compound is the combination of ammonia and boron trichloride.

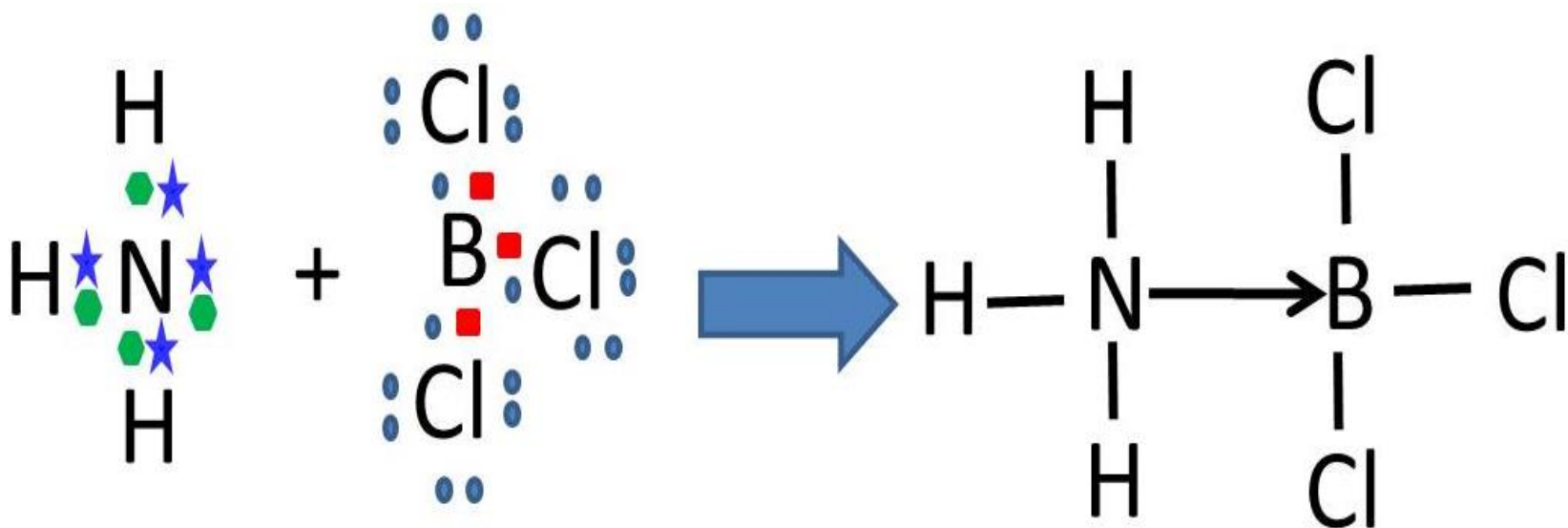

### Distinctive properties of coordination compounds:

1. The melting and boiling points of coordination compounds are higher than those of covalent compounds and lower than those of ionic compounds.
2. Compounds with a coordination bond contain a covalent bond and an ionic bond.

## Chemical bonds

### IV. Hydrogen bond:

- Examples of molecules that bond together through a hydrogen bond are water and hydrogen fluoride.

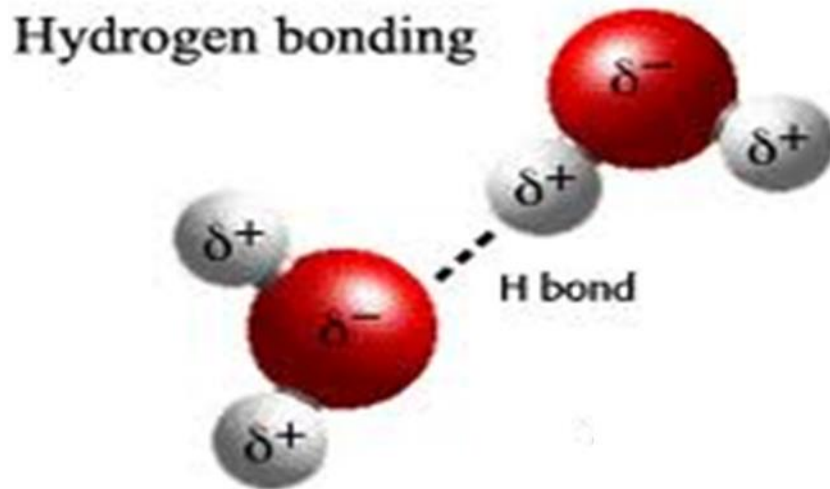

- A hydrogen bond is much weaker and longer than a covalent bond, and its strength depends on the electronegativity of the two atoms that hold it together.



## Chemical bonds

### v. **Metallic bond:**

- **This bond arises between the atoms of the metal through the association of the outer valence electrons of the atoms of the metal with each other, forming an electronic cloud surrounding the nuclei of the metal atoms.**
- **This bond is responsible for the hardness of the metals as well as their high boiling and melting points and their ability to conduct electrically.**

## Chemical bonds

### v. **Metallic bond:**

- The strength of this bond varies from one metal to another, and therefore the metals differ in their electrical conductivity and in some other properties.

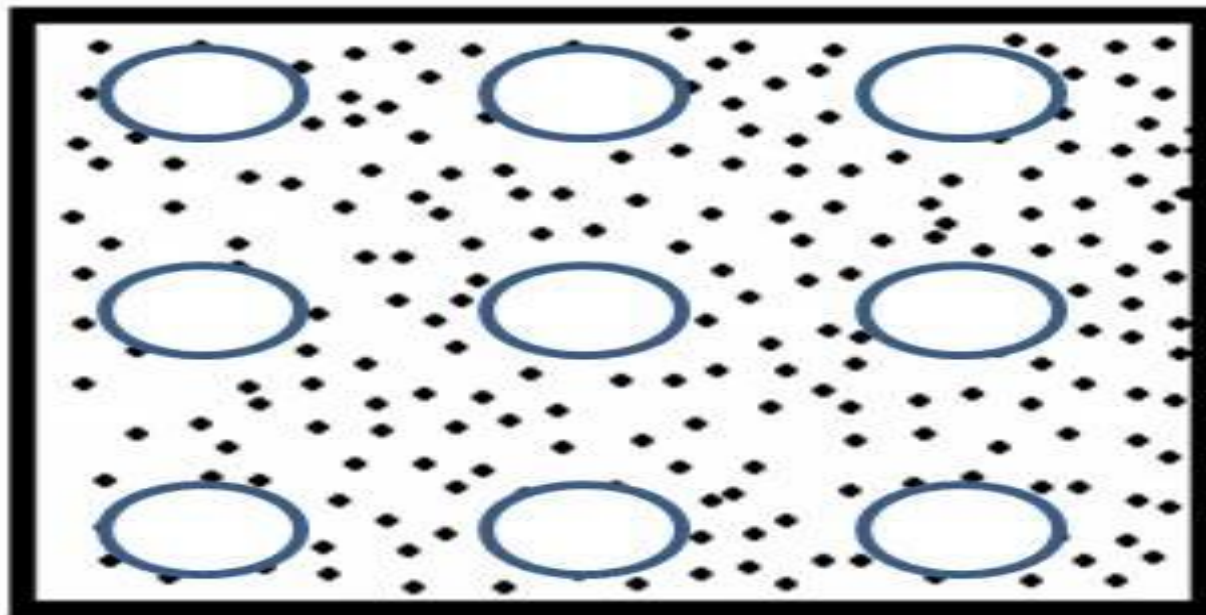

## **First Level (Freshman) - Course's Contents of Physical Science and Geographical Science Programs.**

**Chm 101: General Chemistry (I) - 3 Credits (Lecture 2 Hrs. / W + Lab. 2 Hrs. / W).**

### **Referances:**

- **Paul Monk, Physical Chemistry: understanding our chemical world, John Wiley & Sons Ltd, 2004. McMurry Fay, Chemistry, 4<sup>th</sup> edition.**
- **General Chemistry: Principles and Modern Applications, Ralph Petrucci, F. Herring, Jeffry Madura, Carey Bissonnette, Pearson; 11<sup>th</sup> Edition (March 31, 2016).**