



GEOPHYSICS(I)

Prepared by

Dr. Ali Mahmoud Mahdi

Assistant Prof. of Applied Geophysics

Geology Department ,Faculty of Science, South Valley university

Dr. Moussa fakhary Moussa

Emeritus Prof. of Applied Geophysics

Course Outline

University : South Valley University

Faculty : Faculty of Science

Department: Geology

Program: Geophysics, Geology, and Geology & Chemistry

Course Title: Geophysics (I)

Course Code: 341 G

Total Course Hours: 60 (4 hours x 15 weeks)

Course Description

This course will provide an introduction/ physical Concepts to Geophysics and Geophysical Methods (Gravity, Magnetic, Electric, Seismic).

This course is an attempt to summarize the more important aspects of Geophysics in development and different applications .

Introduction

What is geophysics?

In the broadest sense, the science of **geophysics** is the application of physics to investigations of the Earth, Moon and planets. The subject is thus related to astronomy. Normally, however, the definition of '**geophysics**' is used in a more restricted way, being applied solely to The Earth. To avoid confusion, the use of physics to study the interior of the Earth, from land surface to the inner core, is known as **solid earth geophysics**. This can be subdivided further into **global geophysics**, or alternatively **pure geophysics**, which is the study of the whole or substantial parts of the planet, and **applied geophysics**, which is concerned with investigating the Earth's crust and near-surface. **Applied geophysics** can be defined as Making and interpreting measurements of physical properties of the Earth to determine subsurface conditions, usually with an economic objective, e.g. discovery of fuel or mineral depositions according to sheriff, 2002.

Geophysical methods

Geophysical methods respond to the physical properties of the subsurface media (rocks, sediments, water, voids, etc.) and can be classified into two distinct types

Passive methods: are those that detect variations within the natural fields associated with the Earth, such as the gravitational and magnetic fields.

Active methods: in which artificially generated signals are transmitted into the ground, which then modifies those signals in ways that are characteristic of the materials through which they travel. The altered signals are measured by appropriate detectors whose output can be displayed and ultimately interpreted, such as those used in exploration seismology. The various geophysical methods rely on different physical properties, and it is important that the appropriate technique be used for a given type of application. For example, gravity methods are sensitive to density contrasts within the subsurface geology and so are

ideal for exploring major sedimentary basins where there is a large density contrast between the lighter sediments and the denser underlying rocks. It would be quite inappropriate to try to use gravity methods to search for localized near surface sources of groundwater where there is a negligible density contrast between the saturated and unsaturated rocks. A wide range of geophysical surveying methods exists, for each of which there is an 'operative' physical property to which the method is sensitive.

Table 1. General classifications of geophysical methods

Geophysical Method	Main sources of the fields	Depths of application	Main Application areas	Survey methods
Gravity	- Natural: (gravitational masses of rocks)	Entire of the Earth	Mining Hydrology Plate tectonics Mantle dynamics Core dynamics	Ground Airborne Spaceborne
Magnetostatic	- Natural (Outer Core convection; solar storms; magnetization of near-surface rocks)	0-20 km 3000-6450 km	Basin analysis Plate tectonics Paleo-tectonics Core dynamics	Ground Airborne Spaceborne
DC resistivity	- Artificial (electric current sources)	0-0.1 km	Hydrology Ore mining	Ground
Magnetotelluric	- Natural (Ionospheric events)	0-150 km	Hydrology Plate tectonics	Ground
Electromagnetic induction	- Artificial (electromagnetic induction)	0-10 km	Geologic mapping Ore mining Metal detection	Ground Airborne
Electromagnetic radiation (GPR)	- Artificial (electromagnetic radiation)	0-0.05 km	Geotechnology Hydrology Archeology	Ground Airborne
Seismic reflection	- Artificial (explosives; falling loads)	0-10 km	Basin analysis	Ground
Seismic refraction	- Artificial (explosives; falling loads)	0-150 km	Basin analysis Crustal studies Plate tectonics	Ground
Earthquake seismology	- Natural (earthquakes in the Crust)	10-6450 km	Plate tectonics Mantle dynamics Core dynamics	Ground
Heat flow	- Natural (radioactivity of rocks; secular heat of the Earth)	0.1-120 km	Crustal rheology Plate tectonics Mantle rheology	Ground

Table 2. Methods used in geophysical prospecting and their characteristic properties.

Geophysical Method	Measured property	Investigated physical property	Main practical obstacle
Gravimetry and Gradiometry	Acceleration vector and its gradient	- Density contrast	Relatively small variations in densities of rocks
Magnetostatic	Magnetic field vector	- Magnetic permeability	Low magnetic strength of rocks
DC resistivity	Electric potential change	- Resistivity	Low depth of penetration due to resistivity of rocks
Magnetotelluric	Amplitudes of electromagnetic fields	- Resistivity	Fast attenuation due to conductivity of rocks
Electromagnetic induction	Phase/amplitude change of the magnetic field	- Resistivity - Dielectric permittivity	Fast attenuation due to conductivity of rocks
Electromagnetic radiation (GPR)	Electromagnetic travel time	- Contrasts in electromagnetic wave impedance	Fast attenuation due to conductivity of rocks
Seismic refraction	Seismic travel time	- Seismic velocity	Seismic wave attenuation
Seismic reflection	Seismic travel time	- Contrasts in acoustic wave impedance	Seismic wave attenuation

Table 3 .Average physical properties of some materials encountered in geophysical applications (Data compiled from Clark, 1966; Telford et al., 1976; Parasnis, 1986; and Zhdanov and Keller, 1994).

	Material [§]	Density (g/cm ³)	Magnetic Susceptibility ($\mu/\mu_0 - 1$)	Log Resistivity (Ohm-m)	Dielectric constant (ϵ/ϵ_0)	Seismic velocity (km/sec)
Various	Air	0.001	0	15	1	0.3
	Water	1.0	-7×10^{-10}	0-2	80	1.4-1.5
	Ice	0.9	-7×10^{-10}	6	3-4	3.4
	Oil	0.6-0.9	2×10^{-5}	14	2	1.3
	Salt	2.2	-1×10^{-6}	15	6	4.5-5
Unconsolidated Sediments	Soil	1.5	7×10^{-4} ^a	3	4	0.1-0.2
	Clastics	1.9	5×10^{-4} ^a	3-4	4	1-2
	Sand	1.6	5×10^{-4} ^a	4	4	3
Metal Ores	Oxides	3.8-9.1	3×10^{-3}	(-1)-2	10-25	5.8
	Sulfides	3.8-8.1	3×10^{-3}	(-6)-(-3)	8-31	5.5
Sedimentary rocks	Sandstone	2.2	4×10^{-4} ^a	2-3	5	2-6
	Shale	2.1	6×10^{-4} ^a	0-1	6-8	2.3
	Limestone	2.7	3×10^{-4} ^a	2-3	8-9	3-6
Igneous Rocks	Granites	2.6	2×10^{-3} ^a	4-6	5	5-6
	Basalt	3.0	7×10^{-2} ^a	7	12	5-6
Metamorphics	All	2.6-2.7	5×10^{-3} ^a	3-5	8-10	5.5-6

Gravity Method

Physical basics of gravity method

The basis upon which the gravity method depends is encapsulated in two laws derived by Sir Isaac Newton, which he described in Principia Mathematica (1687) – namely his Universal Law of Gravitation, and his Second Law of Motion. The first of these two laws states that the force of attraction between two bodies of known mass is directly proportional to the product of the two masses and inversely proportional to the square of the distance between their center's of mass (first box 1.1). Consequently, the greater the distance separating the of mass, the smaller is the force of attraction between them.

Newton's Universal Law of Gravitation

$$\begin{aligned} \text{Force} &= \text{gravitational constant} \\ &\times \frac{\text{mass of Earth}(M) \times \text{mass}(m)}{(\text{distance between masses})^2} \\ F &= \frac{G \times M \times m}{R^2} \end{aligned} \quad (1)$$

where the gravitational constant (G) = $6.67 \times 10^{-11} \text{ N m}^2 \text{ kg}^{-2}$.

Newton's law of motion states that a force (F) is equal to mass (m) times acceleration (Box 1.2). If the acceleration is in a vertical direction, it is then due to gravity (g)

$$\begin{aligned} \text{Force} &= \text{mass } (m) \times \text{acceleration } (g) \\ F &= m \times g \end{aligned} \quad (2)$$

Newton's Second Law of Motion

Equations (1) and (2) can be combined to obtain another simple relationship:

$$F = \frac{G \times M \times m}{R^2} = m \times g; \quad \text{thus } g = \frac{G \times M}{R^2} \quad (3)$$

This shows that the magnitude of the acceleration due to gravity on Earth (g) is directly proportional to the mass (M) of the Earth and inversely proportional to the square of the Earth's radius (R). The value of a (or g) at the Earth's surface is about 980 cm s^{-2} but it is NOT constant! In honour of Galileo, the unit of acceleration of gravity is called the Gal.

$$1 \text{ Gal} = 1 \text{ cm s}^{-2}$$

$$1 \text{ mgal} = 0.001 \text{ Gal} = 0.001 \text{ cm s}^{-2} = 0.00001 \text{ m s}^{-2}$$

$$1 \text{ mgal} = 10 \text{ gravity units (g.u)}$$

$$\text{so, } g = 980 \text{ cm s}^{-2} = 980 \text{ Gal}$$

100 mgals is a very large anomaly for the Earth

Instruments can measure to 10^{-6} Gals i.e. 1 microgal.

Variations in (g) reflect variations in altitude, and therefore the shape of the Earth and in the subsurface variation in mass.

So, What Does g Depend On?

The value of gravity on the Earth's surface depends on **five factors**

- (1) Latitude,
- (2) Elevation,
- (3) Topography of the surrounding area,
- (4) Earth tides,
- (5) Subsurface variations in density.

The last factor is the only one of any significance in gravity exploration (and the one which we are interested in), though its effect is generally much smaller than that of the other four combined. So we have to understand and remove the first 4 effects above (will do later), before we can determine the subsurface variation in density.

Table 4. Applications of gravity surveying:-

Hydrocarbon exploration
Hydrocarbon reservoir monitoring
Monitoring of CO ₂ containment underground
Regional geological studies
Isostatic compensation determination
Exploration for, and mass determination of, mineral deposits
Detection of subsurface cavities (micro-gravity), e.g. mine workings, caves, solution features, tunnels
Location of buried rock valleys
Determination of glacier thickness
Tidal oscillations
Archaeogeophysics (micro-gravity), e.g. location of tombs, crypts
Shape of the earth (geodesy)
Military (especially for missile trajectories)
Satellite positioning
Monitoring volcanoes
Hydrological changes in the geoid

How is the Gravitational Acceleration, g, Related to Geology?

Density is defined as mass per unit volume. Consider a simple geologic example of an ore body buried in soil. We would expect the density of the ore body, d_2 , to be greater than the density of the surrounding soil, d_1 .

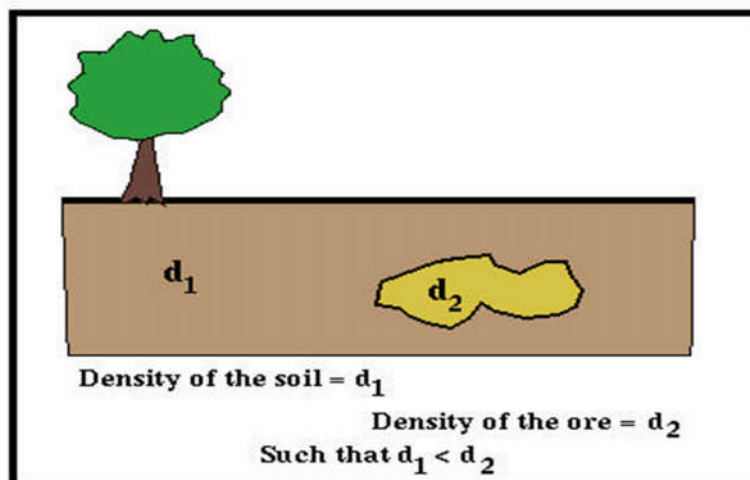

The density of the material can be thought of as a number that quantifies the number of point masses needed to represent the material per unit volume of the material

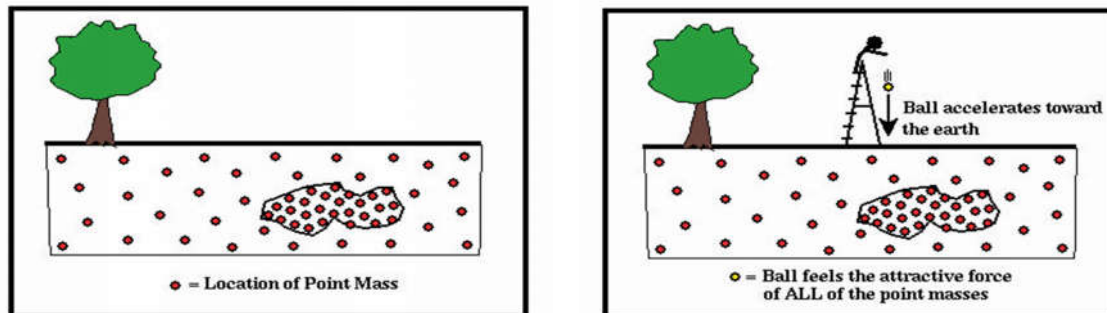

to represent a high-density orebody, we need more point masses per unit volume than we would for the lower density soil. Now, let's qualitatively describe the gravitational acceleration experienced by a ball as it is dropped from a ladder. This acceleration can be calculated by measuring the time rate of change of the speed of the ball as it falls. The size of the acceleration the ball undergoes will be proportional to the number of close point masses that are directly below it. We're concerned with the close point masses because the magnitude of the gravitational acceleration varies as one over the distance between the ball and the point mass squared. The more close point masses there are directly below the ball, the larger its acceleration will be. Because the number of point masses below the ball varies with the location at which it is dropped, map out differences in the size of the gravitational acceleration experienced by the ball caused by variations in the underlying geology. A plot of the gravitational acceleration versus location is commonly referred to as a gravity profile. The Relevant Geologic Parameter is Not Density, But Density Contrast. The shape of the curve describing the variation in gravitational acceleration is not dependent on the absolute densities of the rocks. It is only dependent on the density difference (usually referred to as density contrast) between the ore body and the surrounding soil.

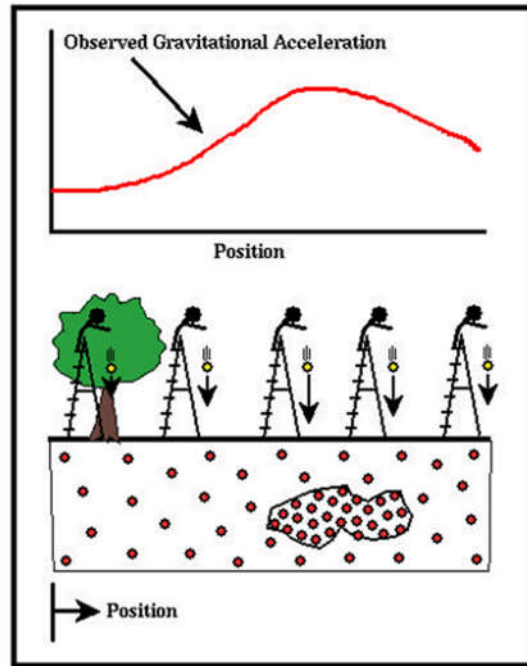

Measurements of gravity provide information about densities of rocks underground. There is a wide range in density among rock types, and therefore geologists can make inferences about the distribution of strata. The gravity method involves measuring the gravitational attraction exerted by the earth at a measurement station on the surface. The strength of the gravitational field is directly proportional to the mass and therefore the density of subsurface materials. Anomalies in the earth's gravitational field result from lateral variations in the density of subsurface materials and the distance to these bodies from the measuring equipment

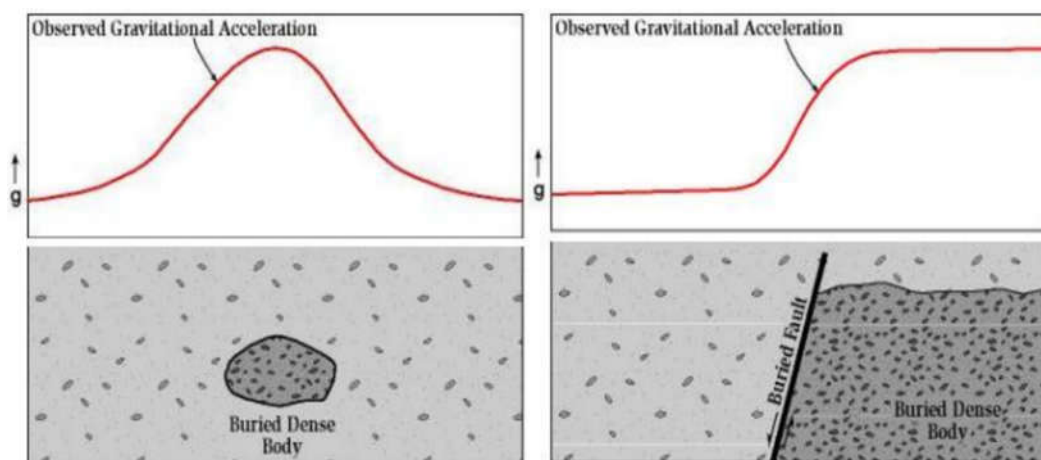

Figure showing the relative surface variation of earth's gravitational acceleration over geologic structures

Density Variations of Earth Materials

To estimate the variation in density of the earth due to local changes in geology. There are, however, several significant complications. The first has to do with the density contrasts measured for various earth materials. The densities associated with various earth materials are shown below

Material	Density (gm/cm ³)
Air	~0
Water	1
Sediments	1.7-2.3
Sandstone	2.0-2.6
Shale	2.0-2.7
Limestone	2.5-2.8
Granite	2.5-2.8
Basalts	2.7-3.1
Metamorphic Rocks	2.6-3.0

The effects of different physical factors on density

Factor	Approximate percentage change in density
Composition	35%
Cementation	10%
Age and depth of burial	25%
Tectonic processes	10%
Porosity and pore fluids	10%

How do we Measure Gravity?

The acceleration due to Gravity typically is measured in one of two ways:

Absolute value :Weight drop, pendulum

Relative value : Mass on a spring

Falling body measurements. These are the type of measurements we have described up to this point. One drops an object and directly computes the acceleration the body undergoes by carefully measuring distance and time as the body falls.

Pendulum measurements. In this type of measurement, the gravitational acceleration is estimated by measuring the period oscillation of a pendulum.

Mass on spring measurements. By suspending a mass on a spring and observing how much the spring deforms under the force of gravity, an estimate of the gravitational acceleration can be determined.

In exploration gravity surveys, the field observations usually do not yield measurements of the absolute value of gravitational acceleration. Rather, we can only derive estimates of variations of gravitational acceleration (relative value).

Falling Body Measurements

The gravitational acceleration can be measured directly by dropping an object and measuring its time rate of change of speed (acceleration) as it falls. It is easy to show that the distance a body falls is proportional to the time it has fallen squared. The proportionality constant is the gravitational acceleration, **g**. Therefore, by measuring distances and times as a body falls, it is possible to estimate the gravitational acceleration.

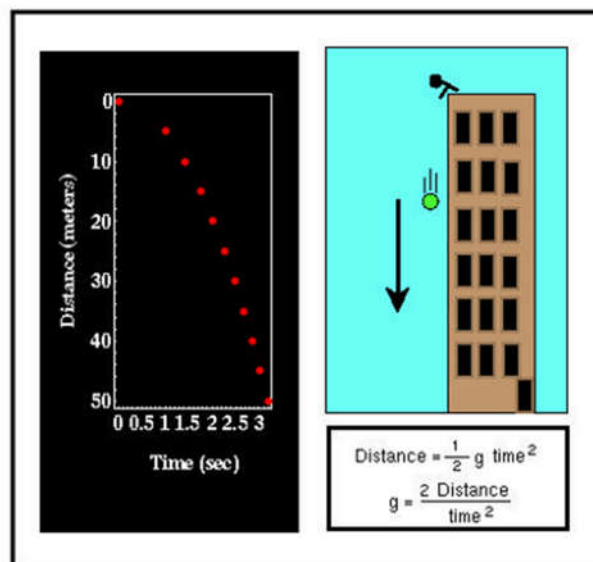

Pendulum Measurements

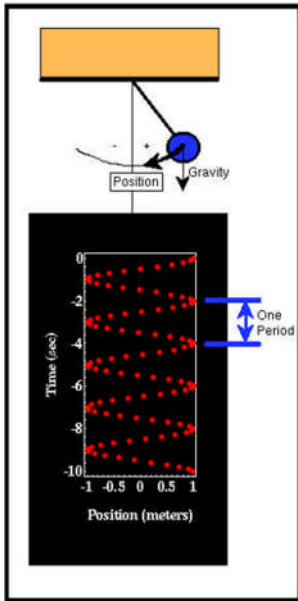

$$T = 2\pi \sqrt{\frac{k}{g}}$$

Another method by which we can measure the acceleration due to gravity is to observe the oscillation of a pendulum. The reason that the pendulum oscillates about the vertical is that if the pendulum is displaced, **the force of gravity** pulls down on the pendulum. The pendulum begins to move downward. When the pendulum reaches vertical it can't stop instantaneously. Because it is the force of gravity that produces the oscillation, one might expect the period of oscillation to differ for differing values of gravity.

In particular, if the force of gravity is small, there is less force pulling the pendulum downward, the pendulum moves more slowly toward vertical, and the observed period of oscillation becomes longer. Thus, by measuring the period of oscillation of a pendulum, we can estimate the gravitational force or acceleration. It can be shown that the period of oscillation of the pendulum, T , is proportional to one over the square root of the gravitational acceleration, g . The constant of proportionality, k , depends on the physical characteristics of the pendulum such as its length and the distribution of mass about the pendulum's pivot point.

Mass and Spring Measurements

The most common type of gravimeter* used in exploration surveys is based on a simple mass-spring system. If we hang a mass on a spring, the force of gravity will stretch the spring by an amount that is proportional to the gravitational force. It can be shown that the

proportionality between the stretch of the spring and the gravitational acceleration is the magnitude of the mass hung on the spring divided by a constant, k , which describes the

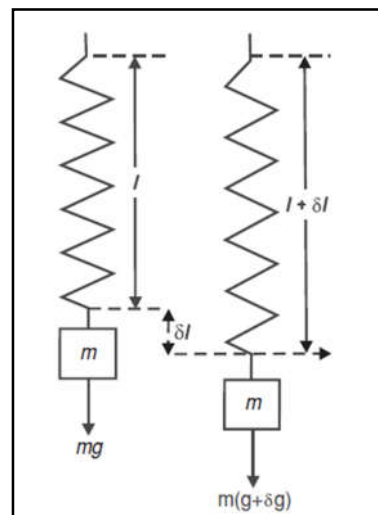

stiffness of the spring. The larger k is, the stiffer the spring is, and the less the spring will stretch for a given value of gravitational acceleration

$\text{Extension to spring} = \text{mass} \times \frac{\text{change in gravity}}{\text{spring constant}} \quad \delta l = \frac{m\delta g}{\kappa}$ $\text{Change in gravity} = \text{constant} \times \text{extension/mass} \quad \delta g = \frac{\kappa\delta l}{m}$

Factors that Affect the Gravitational Acceleration

Factors that affect the gravitational acceleration can be subdivided into two categories:-

1-Temporal Based Variations - These are changes in the observed acceleration that are time dependent. In other words, these factors cause variations in acceleration that would be observed even if we didn't move our gravimeter.

Instrument Drift - Changes in the observed acceleration caused by changes in the response of the gravimeter over time.

Tidal Affects - Changes in the observed acceleration caused by the gravitational attraction of the sun and moon.

2-Spatial Based Variations - These are changes in the observed acceleration that are space dependent. That is, these change the gravitational acceleration from place to place, just like the geologic affects, but they are not related to geology.

Latitude Variations - Changes in the observed acceleration caused by the ellipsoidal shape and the rotation of the earth.

Elevation Variations - Changes in the observed acceleration caused by differences in the elevations of the observation points.

Slab Effects - Changes in the observed acceleration caused by the extra mass underlying observation points at higher elevations.

Topographic Effects - Changes in the observed acceleration related to topography near the observation point.

Instrument Drift

Drift - A gradual and unintentional change in the reference value with respect to which measurements are made. The properties of the materials used to construct the spring can change with time. These variations in spring properties with time can be due to stretching of the spring over time or to changes in spring properties related to temperature changes. To help minimize the latter, gravimeters are either temperature controlled or constructed out of materials that are relatively insensitive to temperature changes. Even still, gravimeters can drift as much as 0.1 mgal per day

Tidal Effect

Variations in gravity observations resulting from the attraction of the moon and sun and the distortion of the earth so produced. This distortion of the solid earth produces measurable changes in the gravitational acceleration because as the shape of the earth changes, the distance of the gravimeter to the center of the earth changes (recall that gravitational acceleration is proportional to one over distance squared). The distortion of the earth varies from location to location, but it can be large enough to produce variations in gravitational acceleration as large as 0.2 mgals.

Reduction (correction) of gravity data

The Effect of latitude

The Earth is an oblate spheroid.

$R_E = 6378 \text{ km}$

$R_P = 6357 \text{ km}$.

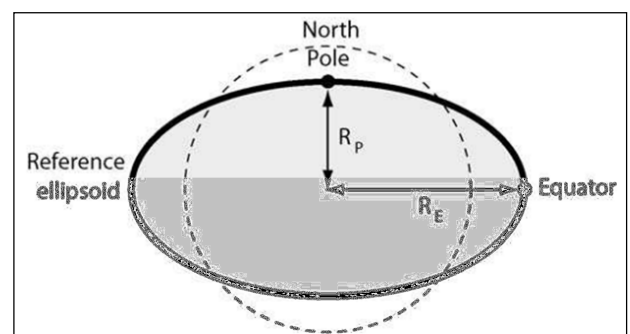

The difference in earth radii measured at the poles(RP)and at the equator(RE) is only 21 km (this value represents a change in earth radius of only 0.3%),this, in conjunction with the earth's rotation, can produce a measurable change in the gravitational acceleration with latitude. Because this produces a spatially varying change in the gravitational acceleration, it is possible to confuse this change with a change produced by local geologic structure. Fortunately, it is a relatively simple matter to correct our gravitational observations for the change in acceleration produced by the earth's elliptical shape and rotation.

The average value of gravity for a given latitude is approximated by the 1967 reference gravity formula, adopted by the International Association of Geodesy

$$g_{\phi} = 9.78031(1+0.005278895 \sin^2\phi+ 0.000023462 \sin^4\phi)$$

where g_{ϕ} is the theoretical gravity for the latitude of the observation point also named normal gravity value. The equation (1) takes into account the fact that the Earth is an imperfect sphere, bulging out at the equator and rotating about an axis through the poles.

The Effect of Elevation

Imagine two gravity readings taken at the same location and at the same time with two perfect (no instrument drift and the readings contain no errors) gravimeters; one placed on the ground, the other placed on top of a step ladder. Would the two instruments record the same gravitational acceleration? No, the instrument placed on top of the step ladder would record a smaller gravitational acceleration than the one placed on the ground. Why? Remember that the size of the gravitational acceleration changes as the gravimeter changes distance from the center of the earth. In particular, the size of the Earth's gravitational acceleration varies as one over the distance squared between the gravimeter and the center of the earth.

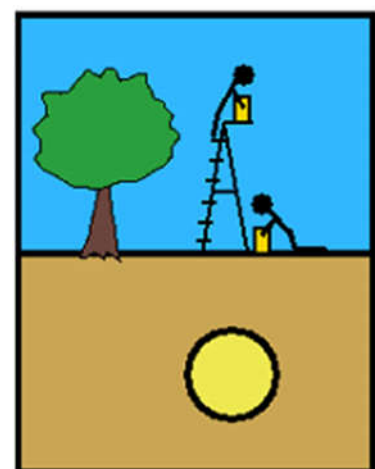

Therefore, the gravimeter located on top of the step ladder will record a

smaller gravitational acceleration, because it is positioned farther from the earth's center than the gravimeter resting on the ground. Therefore, when interpreting data from our gravity survey, we need to make sure that we don't interpret spatial variations in gravitational acceleration that are related to elevation differences in our observation points as being due to subsurface geology. Clearly, to be able to separate these two effects, we are going to need to know the elevations at which our gravity observations are taken. To account for variations in the observed gravitational acceleration that are related to elevation variations, we incorporate another correction to our data known as the Free-Air Correction.

The Free air correction

$$\text{FAC} = 0.3086 h$$

Where

FAC= free air correction (mgal)

h =elevation of the station above sea level datum (m)

If a gravity measurement was made h **above** the reference level, we must **add the FA**

Similarly, if a gravity measurement was made h **below** the reference level, we must **subtract the FAC**

The Effects of excess mass

Changes in the observed acceleration caused by the extra mass underlying observation points at higher elevations. The free-air correction accounts for elevation differences between observation locations. Although observation locations may have differing elevations, these differences usually result from topographic changes along the earth's surface. Thus, unlike the motivation given for deriving the elevation correction, the reason the elevations of the observation points differ is because additional mass has been placed underneath the gravimeter in the form of topography. Therefore, in addition to the gravity readings differing at two stations because of elevation differences, the readings will also contain a difference because there is more mass below the reading taken at a higher elevation than there is of one taken at a lower elevation.

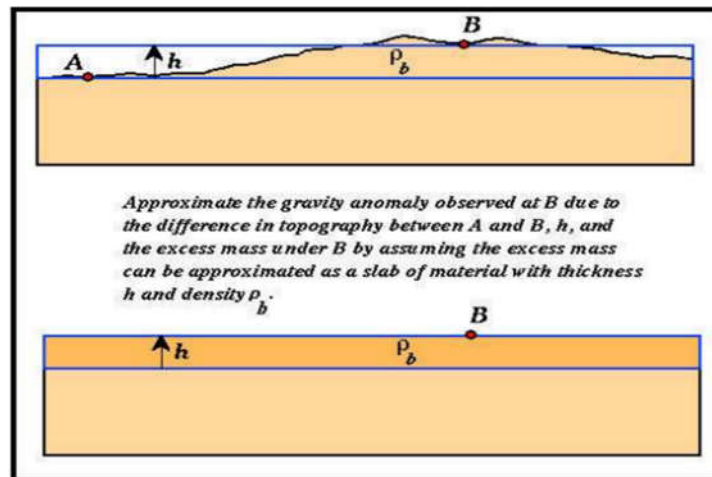

The Bouguer Correction

Corrections based on this simple slab approximation are referred to as the Bouguer Correction. It can be shown that the vertical gravitation a acceleration associated with a flat slab can be written simply as :

$$BC = 0.0419\rho h$$

BC= Bouguer correction

ρ =density of the slab(excess mass)

h= the thickness of excess mass(station elevation)

The correction is given in mgals, ρ is the density of the slab in gm/cm³, and h is the elevation difference in meters between the observation point and elevation datum. h is positive for observation points above the datum level and negative for observation points below the datum level.

The elevation correction

The free-air and Bouguer corrections are commonly combined into one elevation correction

Elevation correction = free air correction – Bouguer correction

$$=(0.30861-0.0419\rho)h$$

Summary

Measurement **above** reference level **Add** Free Air correction **Subtract** Bouguer correction
 Measurement **below** reference level **Subtract** Free Air correction **Add** Bouguer correction

Terrain Corrections

Terrain corrected Bouguer gravity (g_t) - The terrain correction accounts for variations in the observed gravitational acceleration caused by variations in topography near each observation point. Because of the assumptions made during the Bouguer Slab correction, the terrain correction is positive regardless of whether the local topography consists of a mountain or a valley.

Terrain corrections traditionally are made by estimating the differences between the elevation of the station and that of the topography surrounding the station.

Remember that terrain always reduces the gravity reading: mass excess above the station (mountains) pull up on the station, while mass deficiencies below (valleys) “push” (the correction is for a negative mass).

The slab of rock which comprises the hill (mass M) has its centre of mass above the plane on which the gravimeter is situated. There is a force of attraction between the two masses. If the force is resolved into horizontal and vertical components and the latter only is considered, then it can be seen that the measurement of g at the gravity station will be underestimated by an amount δg . Conversely, if the gravity station is adjacent to a valley represents a mass deficiency which can be represented by a negative mass ($-M$). The lack of mass results in the measurement

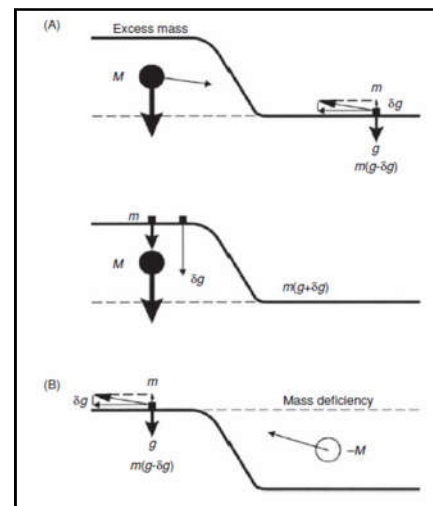

of g to be underestimated by an amount δg . Consequently, a gravity measurement made next to either a hill or a valley requires a correction to be added to it to make allowance for the variable distribution of mass.

Terrain corrections traditionally were made with something called a “Hammer” chart.

These charts divide the regions around the station into pie shaped cylindrical sections. The analyst centers the chart on the station location on a topographic map and estimates

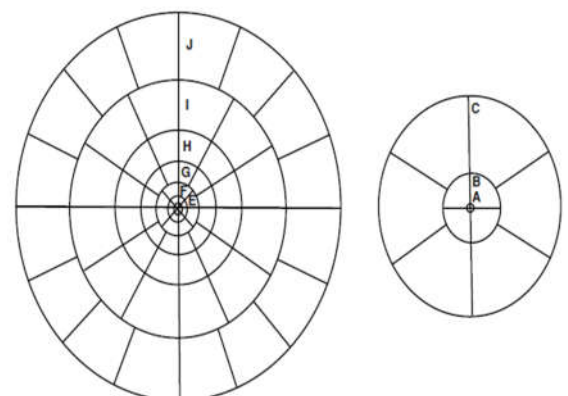

the average elevation difference (note that this is in an absolute value sense!) for all elevations within the section. You multiply this number by a theoretical value for that section, and then add them all up.

Terrain corrections traditionally were made with something called a “Hammer” chart. These charts divide the regions around the station into pie shaped cylindrical sections. The analyst centers the chart on the station location on a topographic map and estimates the average elevation difference (note that this is in an absolute value sense!) for all elevations within the section. You multiply this number by a theoretical value for that section, and then add them all up.

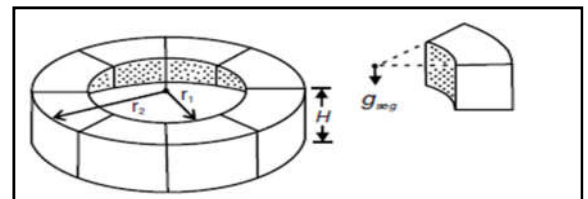

Gravity of a Hammer chart segment (δg_{seg}):

$$\delta g_{seg} = \frac{2\pi\rho G}{N} [r_2 - r_1 + (r_1^2 + z^2)^{1/2} - (r_2^2 + z^2)^{1/2}] \text{ (g.u.)}$$

where N is the number of segments in the ring, z is the modulus of the difference in elevation between the gravity station and mean elevation of the segment, and ρ is the Bouguer correction density (Mg/m^3).

Building Correction

One additional aspect of terrain corrections is the effect of buildings adjacent to the gravimeter during data acquisition in built-up areas. Modern, thin-walled buildings may contribute only a small effect (of the order of $1\text{--}5\mu\text{Gal}$), but older thick-walled constructions may give rise to an effect of $10\text{--}30\mu\text{Gal}$ depending upon the distance between the building and the gravity meter. In these cases, it is preferable to position the gravimeter more than 2.5 m away from such a building in order to keep the effect to less than $5\mu\text{Gal}$ (Milsom, 2003). Otherwise, it is necessary to determine the

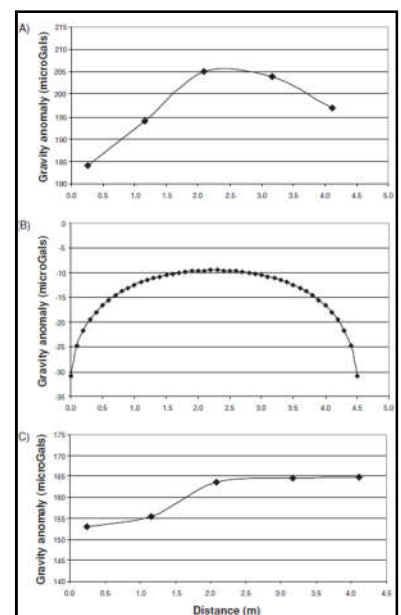

localized effects of buildings.

There are three approaches to dealing with the effects of buildings:

- (a) ignore them – not acceptable these days;
- (b) empirical approach to remove the effects; or
- (c) calculate and remove the effect.

The empirical approach is to measure the gravity effect around a comparable building, assuming one exists, away from the survey area, and to carry out an adjustment of the actual survey data. For example, five gravity stations were occupied across a 4.25 m wide alley between two houses (Figure A). The gravity field over the same profile was modeled (Figure B) and used to correct the Bouguer anomaly profile. It can be seen in the corrected profile (Figure C) that the three data values along the right-hand end of the profile are generally the same whereas the first two show lower values by around 12 μGal . This zone was later shown by the probe drilling to be, as predicted from the geophysical interpretation, due to collapsed backfilled mine workings. This approach was taken across the entire survey area to produce a Bouguer anomaly fully corrected for the effects of buildings. Obtaining mini-profiles orthogonal to major walls and comparing them with calculated building corrections is a useful way of determining the effectiveness of the building correction and the rate of decay of the field from the building, especially in the case of more complex architectural detail and different building materials.

Eötvös correction

For a gravimeter mounted on a vehicle, such as a ship or a helicopter, the measured gravitational acceleration is affected by the vertical component of the acceleration, which is a function of the speed and direction in which the vehicle is travelling.

There are two components to this correction.

1-The first is the outward-acting centrifugal acceleration associated with the movement of the vehicle travelling over the curved surface of the Earth and

2- the second is the change in centrifugal acceleration resulting from the movement of the vehicle relative to the Earth's rotational axis.

In the second case, an object that is stationary on the Earth's surface is travelling at the speed of the Earth's surface at that point as it rotates around the rotational axis in an east-west direction. If that same object is then moved at x km/h towards the east, its speed relative to the rotational velocity is increased by the same amount. Conversely, if it travels at a speed of y km/h in a westerly direction its relative speed is slowed by the same amount. Any movement of a gravimeter which involves a component in an east-west direction will have a significant effect on the measurement of gravity. The effect is to decrease the reading taken from an eastward moving vehicle, and increase the reading from a westward moving one.

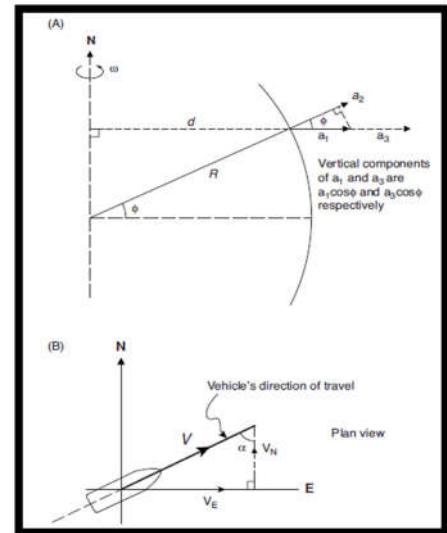

Isostatic Correction

According to the isostatic theory, there are, in certain parts of the Earth's crust, indications of lateral density variations to a large scale-extent which would cause corresponding changes in the Earth's gravity. This is supported by the large and negative Bouguer anomaly normally observed over continental blocks and some mountainous areas.

Pratt's model was developed by Heiskanen (1938), who suggested that density changes laterally with variable thickness of crust and that density increases gradually with depth.

Airy's isostatic model for the Earth's crust suggests that mountain ranges (such as the Alps and the Rocky Mountains) have roots bulging through the upper Mantle of the Earth. Such roots (being of lower density

relative to its surrounding) would cause the Bouguer anomaly to decrease by an amount depending on the shape of the root and its density contrast.

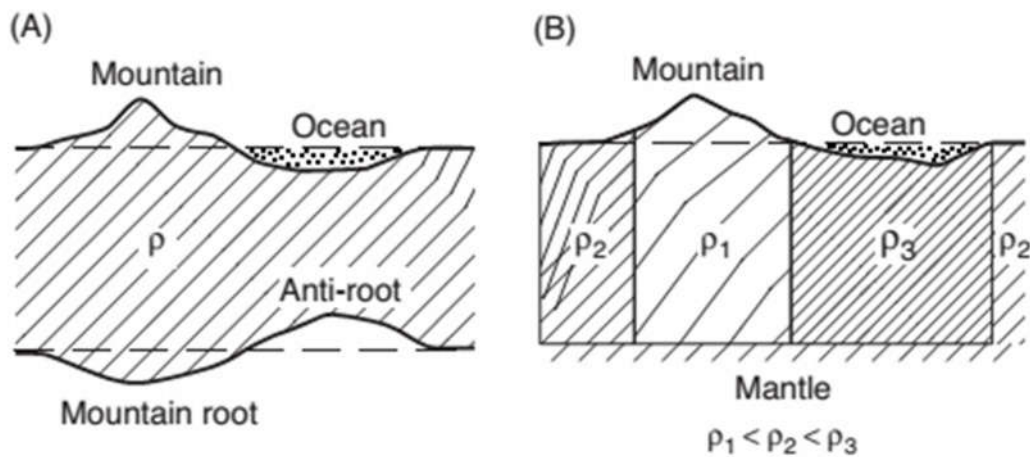
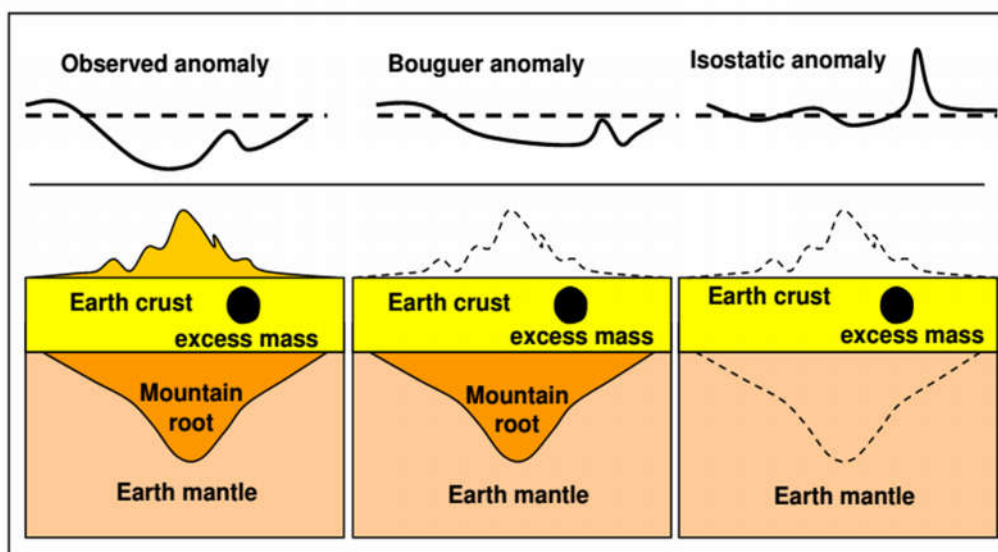

Figure 2.31 (A) Airy and (B) Pratt's models for isostasy.



The isostatic anomaly (Δg_I) is thus defined to be the Bouguer anomaly (Δg_B) added to which is the isostatic correction (IC), that is

$$\Delta g_I = \Delta g_B + IC$$

Summary of Gravity Types

We have now described the host of corrections that must be applied to our observations of gravitational acceleration to isolate the effects caused by geologic structure. The wide variety of corrections applied can be a bit intimidating at first and has led to a wide variety of names used in conjunction with gravity observations corrected to various degrees

Observed Gravity (gobs) - Gravity readings observed at each gravity station after corrections have been applied for instrument drift and tides.

Latitude Correction (gn) - Correction subtracted from gobs that accounts for the earth's elliptical shape and rotation. The gravity value that would be observed if the earth were a perfect (no geologic or topographic complexities), rotating ellipsoid is referred to as the normal gravity.

Free Air Corrected Gravity (gfa) - The Free-Air correction accounts for gravity variations caused by elevation differences in the observation locations. The form of the Free-Air gravity anomaly, **gfa**, is given by;

$$\mathbf{gfa = gobs - gn + 0.3086h \text{ (mgal)}}$$

where **h** is the elevation at which the gravity station is above the elevation datum chosen for the survey (this is usually sea level).

Bouguer Slab Corrected Gravity (gb) - The Bouguer correction is a first-order correction to account for the excess mass underlying observation points located at elevations higher than the elevation datum. Conversely, it accounts for a mass deficiency at observations points located below the elevation datum. The form of the Bouguer gravity anomaly, **gb**, is given by;

$$\mathbf{gb = gobs - gn + 0.3086h - 0.04193rh \text{ (mgal)}}$$

where **r** is the average density of the rocks underlying the survey area.

Terrain Corrected Bouguer Gravity (gt) - The Terrain correction accounts for variations in the observed gravitational acceleration caused by variations in topography near each observation point. The terrain correction is positive regardless of whether the local topography consists

of a mountain or a valley. The form of the Terrain corrected, Bouguer gravity anomaly, g_t , is given by;

$$g_t = g_{obs} - g_n + 0.3086h - 0.04193r + TC \text{ (mgal)}$$

where TC is the value of the computed Terrain correction. Assuming these corrections have accurately accounted for the variations in gravitational acceleration they were intended to account for, any remaining variations in the gravitational acceleration associated with the Terrain Corrected Bouguer Gravity, g_t , can now be assumed to be caused by geologic structure.

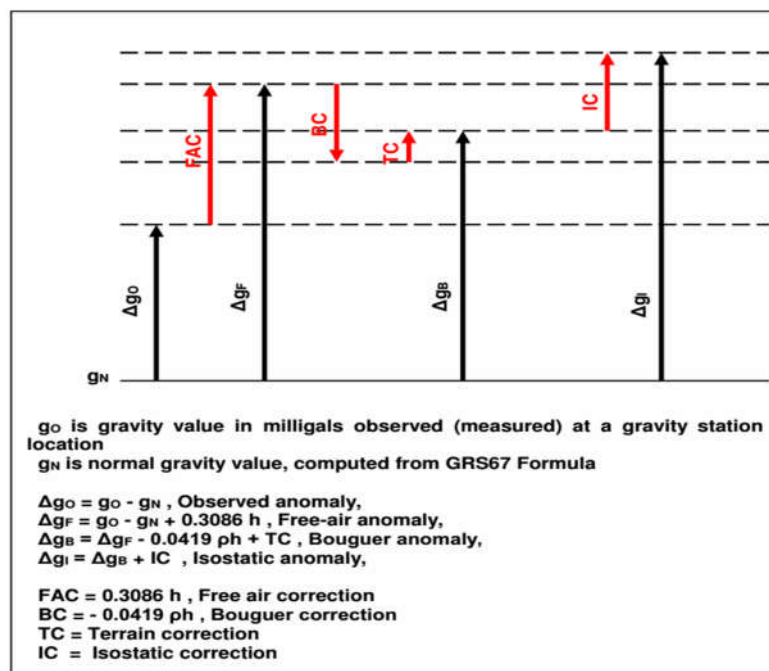

Gravity Anomaly Over a simple shape bodies

Gravity anomalies associated with different geometric form geological structures

Models	Geological structure	Gravity Anomaly	Depth rule
Sphere	Compact bodies, salt domes	$\Delta g_{sphere} = \frac{G4\pi R^3 \Delta \rho}{3} \times \frac{z}{(x^2 + z^2)^{3/2}}$ Universal Gravitational Constant $G = 6.672 \times 10^{-11} \text{ m}^3\text{kg}^{-1}\text{s}^{-2}$	$z \leq 1.305x_{1/2}$
Horizontal cylinder	Ridges, valleys, tunnels	$\Delta g_{Horizontal-Cylinder} = G2\pi R^2 \Delta \rho \frac{z}{(x^2 + z^2)}$	$z \leq x_{1/2}$
Vertical cylinder	Volcanic necks, plugs, small cavities, sinkholes	$\Delta g_{Vertical-Cylinder} = G2\pi \Delta \rho (h_2 - h_1 + \sqrt{R^2 + h_1^2} - \sqrt{R^2 + h_2^2})$ $\Delta g_{Vertical-Cylinder} = G2\pi \Delta \rho (\sqrt{R^2 + h_1^2} - h_1)$ when $h_2 \rightarrow \text{infinity}$	$z \leq 1.732x_{1/2}$
Infinite slab	Sedimentary basins, plutons, ice caps	$\Delta g_B = 2\pi G \Delta \rho \Delta h$	
Semi infinite slab		$\Delta g_{semi-sheet} = 2G\Delta \rho t \left(\frac{\pi}{2} + \tan^{-1} \frac{x}{z} \right)$	
Faulted sheet		$\Delta g_{faulted_sheet} = 2G\Delta \rho t \left[\pi + \tan^{-1} \left(\frac{x}{z_1} + \cot \phi \right) - \tan^{-1} \left(\frac{x}{z_2} + \cot \phi \right) \right]$	

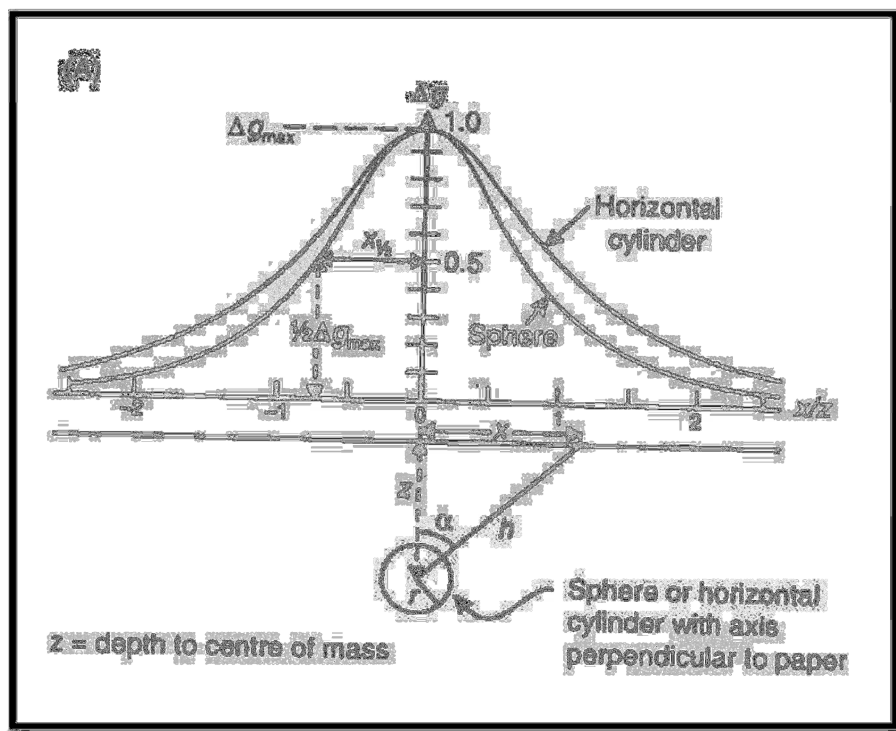

$$\Delta g_{sphere} = \frac{G4\pi R^3 \Delta \rho}{3} \times \frac{z}{(x^2 + z^2)^{3/2}}$$

Gravity Anomaly Over a Buried Horizontal cylinder

$$\Delta g_{\text{Horizontal-Cylinder}} = G2\pi R^2 \Delta\rho \frac{Z}{(X^2 + Z^2)}$$

The maximum value of g is located directly above the axis of the cylinder where $x=0$

$$g_{\text{max}} = G2\pi R^2 \Delta\rho / Z$$

where G = is the gravitational constant

R = sphere or cylinder radius

$\Delta\rho$ = density contrast of the sphere or cylinder with the surrounding rock = ρ of buried body - ρ of the surrounding

Z = the depth to the center of the sphere or cylinder

Note that

if you use $G=6.67 \times 10^{-11}$ then X, Z and R will be in meter and $\Delta\rho$ in kg/m^3 the resulting $\Delta g = \text{m/S}^2$

if you use $G=6.67 \times 10^{-8}$ then X, Z and R will be in Cm and $\Delta\rho$ in gr/Cm^3 the resulting $\Delta g = \text{gal}$

Factors that affect the gravity anomaly profile

- 1- Positive vs. negative density contrasts
- 2- Changing mass anomaly
- 3- Changing depth

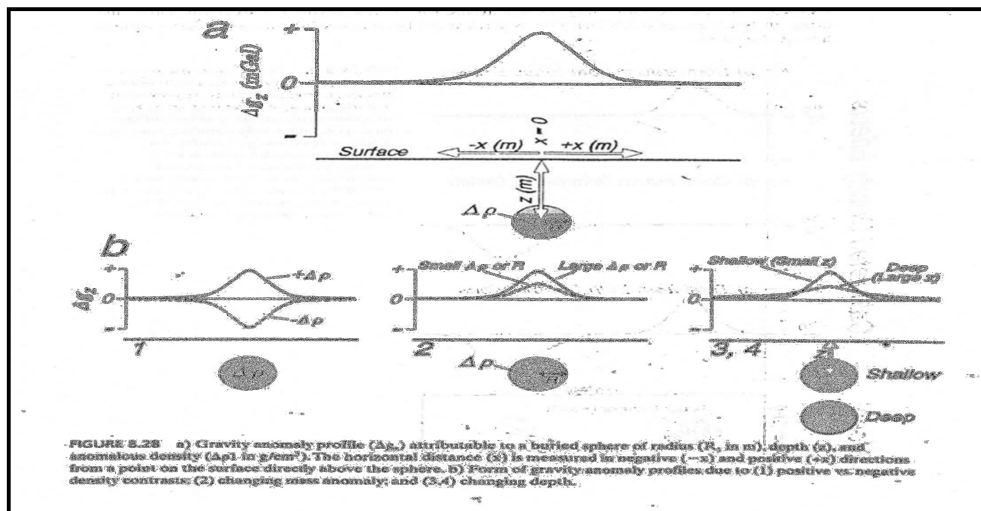

Applications of Gravity Method

❖ Engineering applications

The size of engineering site investigations is normally such that very shallow (<50 m) or small-scale (hundreds of square metres) geo-logical problems are being targeted. Consequently, the resolution required for gravity measurements is of the order of <5 μ Gals. The use of gravity is commonly to determine the extent of disturbed ground where other geophysical methods would fail to work because of particularly high levels of electrical or acoustic noise, or because of the presence of a large number of underground public utilities (Kick, 1985). Additionally, gravity is used to assess the volume of anomalous ground, such as the size of underground cavities or of ice lenses.

❖ Petroleum Exploration

Petroleum exploration and production are concerned with the geological interpretation of geophysical data, especially in offshore areas.

- There are three main geophysical methods used in petroleum exploration: Magnetic, gravity and seismic.
- The first two of these methods are used only in the predrilling phase. Seismic surveying is used in both exploration and development phases.

Gravity Surveying

In some conditions, gravity maps may indicate a drillable prospect by locating salt domes and reefs (because of their low density). One of the first applications of gravity exploration was in the search for salt diapirs. Petroleum is often trapped around the edges of diapirs. Salt diapirs are easily recognized as "round" low-gravity anomalies representing low sub-surface density. Salt is less dense than country rock

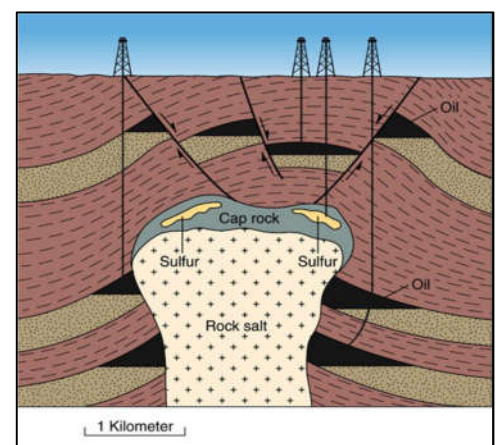

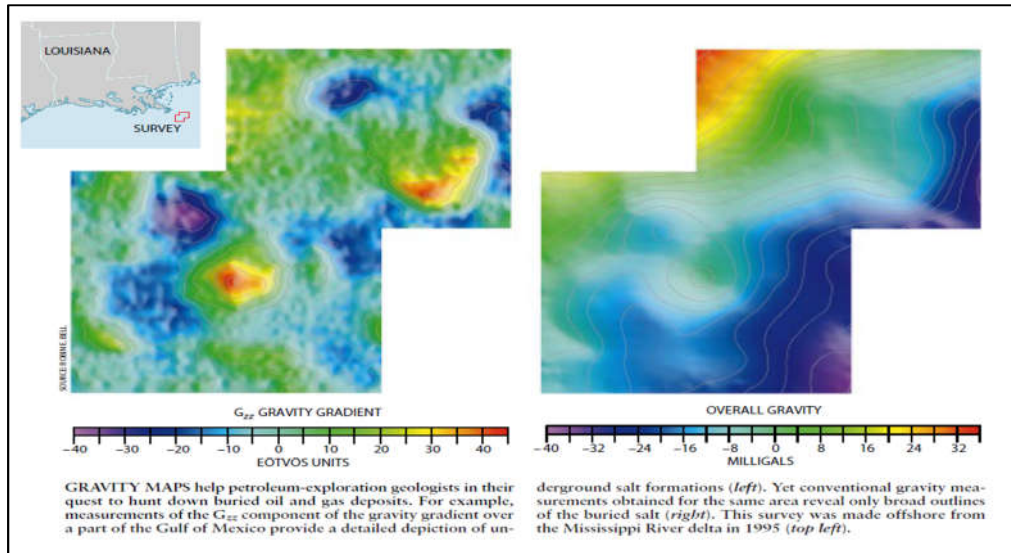

❖ Mineral exploration

Gravity surveys have two roles in exploration for minerals:

- (1) for search and discovery of the ore body; and
- (2) as a secondary tool to delimit the ore body and to determine the tonnage of ore

The reason for the failure of the gravity method in this case is two-fold

- **The scale of mineralization**, which is a stock work of mineralized veins, was of the order of only **a few meters wide**.
- **The sensitivity of the gravimeter was insufficient** to resolve the small density contrast between the sulphide mineralization and the surrounding rocks. Most metallic minerals are more dense than the surrounding country rock and, if shallow enough, show distinct gravity anomaly highs.

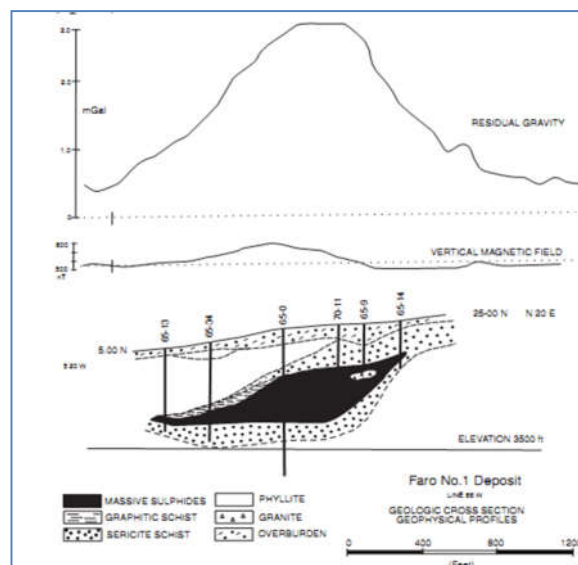

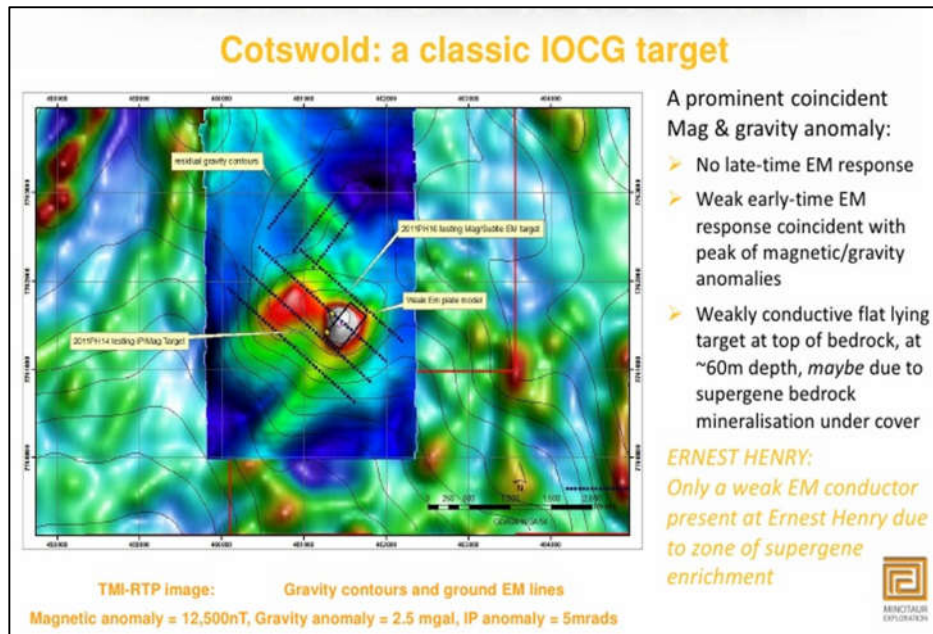

❖ Detection of natural and man-made cavities

Hidden voids within the near-surface can become **serious hazards** if exposed unwittingly during excavation work, or if they become obvious by subsidence of the overlying ground .

The detection of suspected cavities using gravity methods has been achieved in many engineering and hydrogeological surveys (e.g. Colley, 1963). The application of micro-gravimeter to the detection of underground cavities .

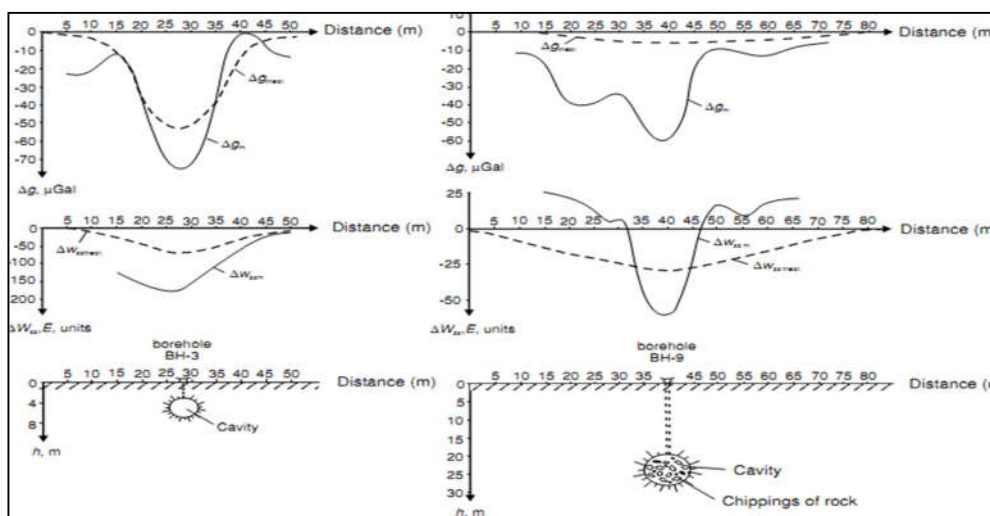

Magnetic Method

General

Magnetic Survey -Measurements of the magnetic field or its components at a series of different locations over an area of interest, usually with the objective of locating concentrations of magnetic materials or of determining depth to basement Since the early 1970s, magnetic gradiometers have been used which measure not only the total Earth's magnetic field intensity, but also the magnetic gradient between sensors. This provides extra information of sufficient resolution to be invaluable in delimiting geological targets.

History of the magnetic method

- Oldest Branch of Geophysics
 - Chinese first to use north-seeking properties of lodestone
 - 1600 William Gilbert publishes *De Magnete*: ‘...the whole earth is a magnet’
- Prospecting
 - Began in Sweden for iron ore in 1640's
 - Thalen and Tiberg (1870) measured Earth's magnetic fields
 - A. Schmidt (1915) developed a balance magnetometer
 - During WWII instruments became smaller and easier to use
- Now, magnetic tools are one of the most cheaply and easiest to acquire geophysical data sets

Applications of magnetic Method:-

Applications

- Shallow (Engineering and Environmental): contaminants, toxic waste, pipes, cables and metal inclusions
- Military: location of UXO's
- Archeology: buried walls, old fire pits
- Mining: iron sulfide deposits
- Oil and groundwater: depth to magnetic basement in basins, detection of faults
- Geotectonics: major player in discovery of, and current analysis of tectonic processes.

Basic concepts and units of magnetic method

Magnetic Monopoles

If two magnetic poles of strength m_1 and m_2 are separated by a distance r , a force exists between them is

$$F = \frac{m_1 m_2}{4\pi\mu r^2}$$

where μ is the magnetic permeability of the medium separating the poles; m_1 and m_2 are pole strengths and r the distance between them.

If the poles are of the same sort, the force will push the poles apart, and if they are of opposite polarity, the force is attractive and will draw the poles towards each other Magnetic dipole

The fundamental magnetic element appears to consist of two magnetic monopoles, one positive and one negative, separated by some distance.

This fundamental magnetic element consisting of two monopoles is called a magnetic dipole. In fact, a bar magnet can be thought of as nothing more than two magnetic monopoles separated by the length of the magnet. The magnetic force appears to originate out of the north pole, N, of the magnet and to terminate at the south pole, S, of the magnet.

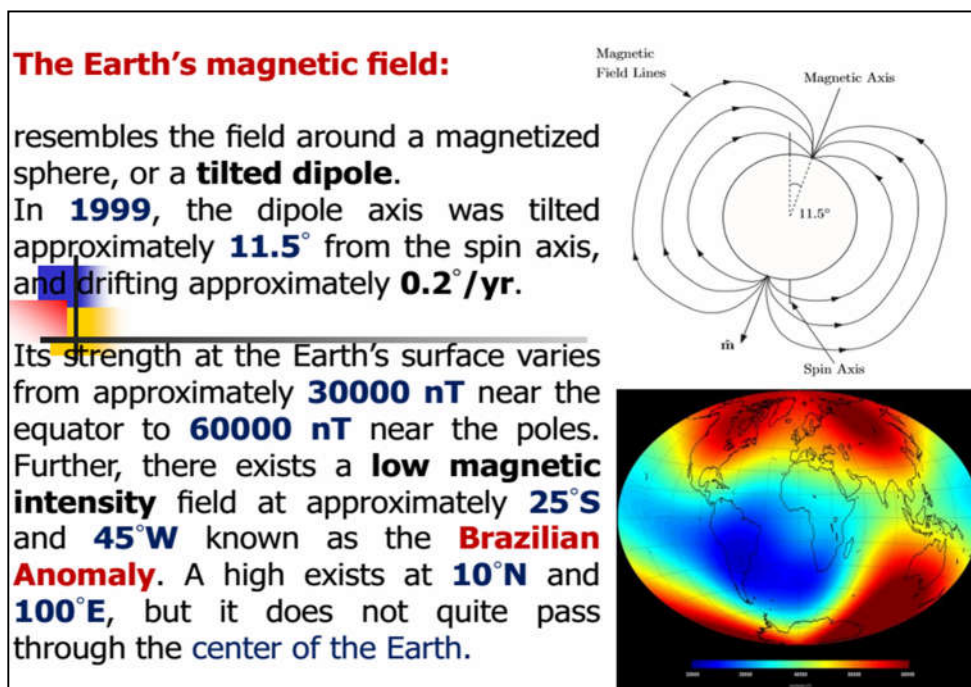
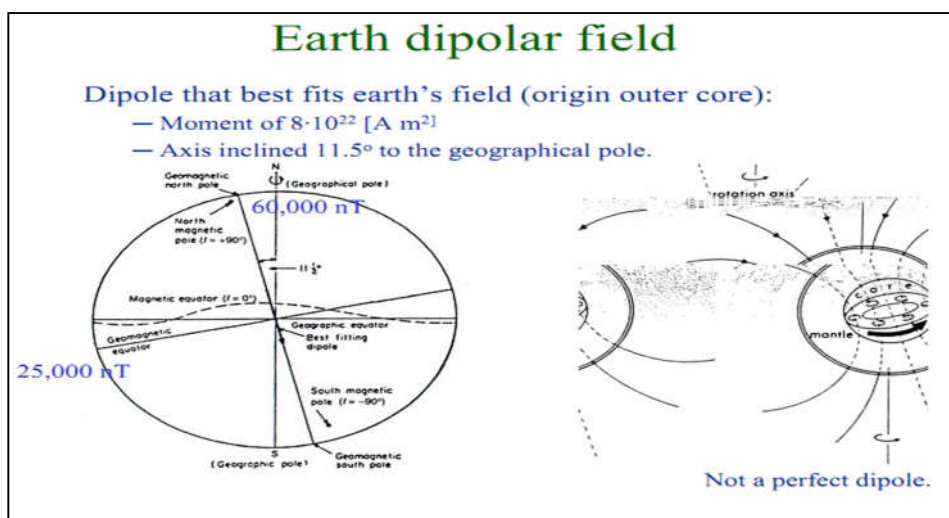
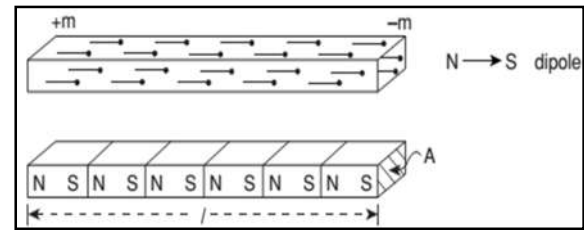

Magnetic Induction

When a magnetic material, say iron, is placed within a magnetic field, H , the magnetic material will produce its own magnetization. This phenomena is called **induced magnetization**. In practice, the induced magnetic field (that is, the one produced by the magnetic material) will look like it is being created by a series of magnetic dipoles located within the magnetic material and oriented parallel to the direction of the inducing field, H .

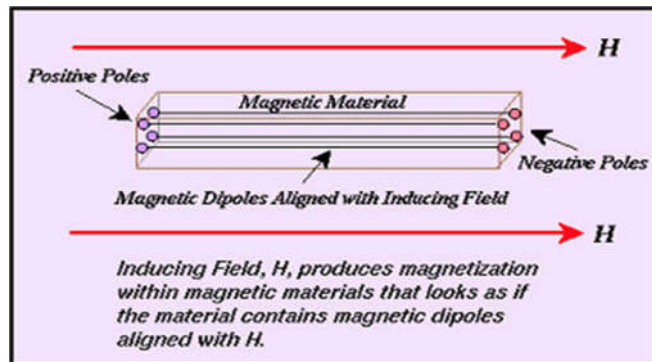

The strength of the magnetic field induced by the magnetic material due to the inducing field is called the intensity of magnetization, I .

Magnetic Susceptibility

The intensity of magnetization, I , is related to the strength of the inducing magnetic field, H , through a constant of proportionality, k , known as the magnetic susceptibility. The $I = kH$ magnetic susceptibility is a unit less constant that is determined by the physical properties of the magnetic material. It can take on either positive or negative values. Positive values imply that the induced magnetic field, I , is in the same direction as the inducing field, H . Negative values imply that the induced magnetic field is in the opposite direction as the inducing field. In magnetic prospecting, the susceptibility is the fundamental material property whose spatial distribution we are attempting to determine. In this sense, magnetic susceptibility is analogous to density in gravity surveying.

Mechanisms for Induced Magnetization

The nature of magnetization material is in general complex, governed by atomic properties

There are three types of magnetic materials:

- 1- Diamagnetic
- 2- Paramagnetic
- 3- Ferromagnetic

Diamagnetism

- This form of magnetism is a fundamental property of all materials and is caused by the alignment of **magnetic moments** associated with orbital electrons in the presence of an external magnetic field.
- For those elements with **no unpaired electrons** in their outer electron shells.
- this is the only form of magnetism observed.
- The susceptibilities of diamagnetic materials are **relatively small and negative**.
- Quartz, salt, calcite, water are two common diamagnetic earth materials

Diamagnetism ($\kappa < 0$)

- External magnetic field **H** causes distortion of electron-orbit (**Lorentz force**)
- Precession of orbital plane around **H** direction (**Larmor-precession**)
- A second magnetic moment is created but opposite to **H** (**Lenz rule**)
- Precession frequency depends on **H**
- in all materials
- weak, best observed in materials
- without a resulting spin momentum

	Field dependence	Temperature dependence															
<table style="width: 100%; border-collapse: collapse;"> <tr> <td style="width: 15%;">Calcite</td> <td style="width: 15%;">CaCO₃</td> <td style="width: 70%;">- 0.48 x 10⁻⁸ m³/kg</td> </tr> <tr> <td>Quartz</td> <td>SiO₂</td> <td>- 0.62 x 10⁻⁸ m³/kg</td> </tr> <tr> <td>Water</td> <td>H₂O</td> <td>- 0.90 x 10⁻⁸ m³/kg</td> </tr> </table>	Calcite	CaCO ₃	- 0.48 x 10 ⁻⁸ m ³ /kg	Quartz	SiO ₂	- 0.62 x 10 ⁻⁸ m ³ /kg	Water	H ₂ O	- 0.90 x 10 ⁻⁸ m ³ /kg								
Calcite	CaCO ₃	- 0.48 x 10 ⁻⁸ m ³ /kg															
Quartz	SiO ₂	- 0.62 x 10 ⁻⁸ m ³ /kg															
Water	H ₂ O	- 0.90 x 10 ⁻⁸ m ³ /kg															
<table style="width: 100%; border-collapse: collapse;"> <tr> <td style="width: 15%; text-align: center;">H</td> <td style="width: 15%; text-align: center;">1s¹</td> <td style="width: 70%;"></td> </tr> <tr> <td style="text-align: center;">↑</td> <td></td> <td></td> </tr> <tr> <td style="text-align: center;">H</td> <td style="text-align: center;">1s¹</td> <td></td> </tr> <tr> <td></td> <td></td> <td style="text-align: center;">O 1s² 2s² 2p⁴</td> </tr> <tr> <td></td> <td></td> <td style="text-align: center;">↓ ↓ ↓</td> </tr> </table>	H	1s ¹		↑			H	1s ¹				O 1s ² 2s ² 2p ⁴			↓ ↓ ↓		
H	1s ¹																
↑																	
H	1s ¹																
		O 1s ² 2s ² 2p ⁴															
		↓ ↓ ↓															

Paramagnetism

- Unpaired electrons in incomplete electron shells produce unbalanced spin magnetic moments and weak magnetic interactions, between atoms in *paramagnetic* materials such as fayalite, amphiboles, pyroxenes, olivines, garnets and biotite.
- In an external applied field, the magnetic moments align themselves into the same direction, although this process is retarded by thermal agitation.
- The susceptibilities of paramagnetic substances are small(weak) and positive

Paramagnetism ($\kappa > 0$)

- In materials with orbital **momentum and spin momentum**
- No overlapping of orbitals -> no electron exchange
- No long-range ordering of magnetic moments
- **Magnetic moments** are randomly oriented
- **external magnetic fields:** partial alignment of unpaired spins
- Efficiency depends on **field intensity** and on **temperature**

- **Stronger** than diamagnetism but weaker than ferromagnetism
- **Positive field** dependence, **temperature dependence**

Clay		$15 \times 10^{-8} \text{ m}^3/\text{kg}$	
Pyrite	FeS₂	$30 \times 10^{-8} \text{ m}^3/\text{kg}$	
Siderite	FeCO₃	$123 \times 10^{-8} \text{ m}^3/\text{kg}$	

Field dependence

Temperature dependence

Ferromagnetism

In *ferromagnetic* materials the susceptibility is large but is dependent upon temperature and the strength of the applied magnetic field. The spin moments of unpaired electrons are coupled magnetically due to the very strong interaction between adjacent atoms and overlap of electron orbits . The magnetic coupling can be such that the magnetic moments are aligned either parallel or

anti-parallel as in an anti-ferromagnetic substance.

There are three varieties

A- Pure Ferromagnetism

B- Anti ferromagnetism

C- Ferrimagnetism

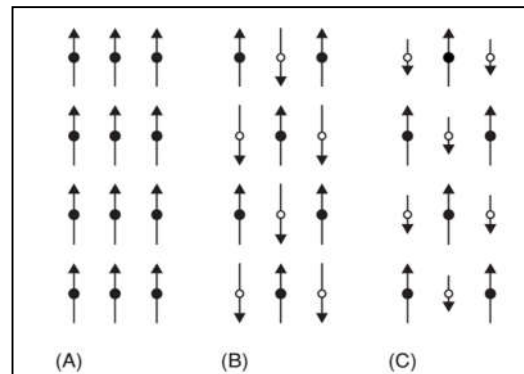

Pure Ferromagnetism

The directions of electron spin alignment within each domain are almost all parallel to the direction of the external inducing field. Pure ferromagnetic substances have large positive susceptibilities. Ferromagnetic minerals do not exist, but iron, cobalt, and nickel are examples of common ferromagnetic elements.

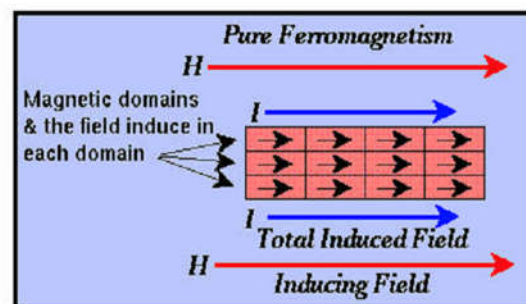

Antiferromagnetism

The directions of electron alignment within adjacent domains are opposite and the relative abundance of domains with each spin direction is approximately equal. The observed magnetic intensity for the material is almost zero. Thus, the susceptibilities of antiferromagnetic materials are almost zero. Hematite is an antiferromagnetic material

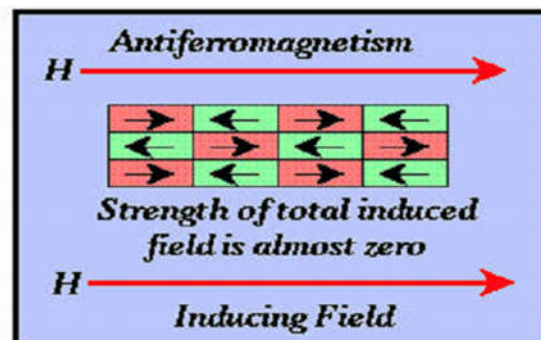

Ferrimagnetism

A Ferrimagnetic material, such as magnetite (Fe₃O₄), is one where one of the two anti-parallel magnetic

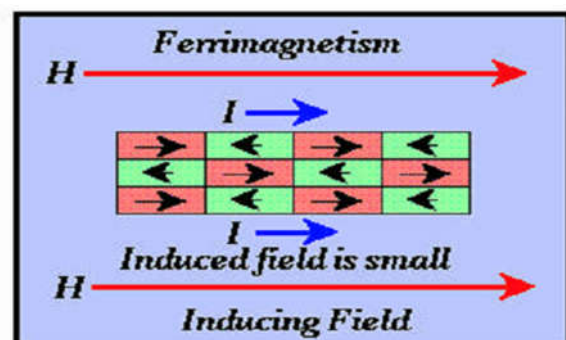

moments is stronger than the other. The most important magnetic minerals are Ferrimagnetic and include magnetite, titanomagnetite, ilmenite, and pyrrhotite

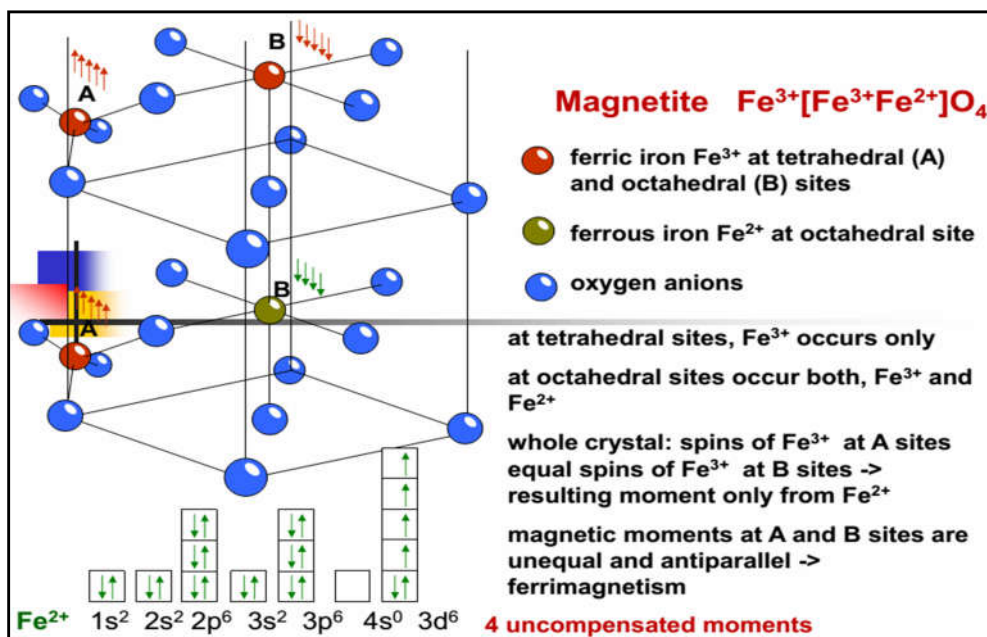

Magnetic iron minerals

Magnetite (Fe_3O_4):

$M_s = 480 \text{ kA/m}$, $T_c = 580 \text{ }^\circ\text{C}$, $T_v = -150 \text{ }^\circ\text{C}$

in soils, bacteria, lacustrine/marine sediments, oxidised, also in human and animal tissue, combustion product

Maghaemite ($\gamma\text{-Fe}_2\text{O}_3$):

$M_s = 380 \text{ kA/m}$, ($T_c = 590\text{-}675 \text{ }^\circ\text{C}$)

weathering product (oxidised magnetite), in soils and sedimentary rocks, combustion product

Haematite ($\alpha\text{-Fe}_2\text{O}_3$):

$M_s = \sim 2.5 \text{ kA/m}$, $T_c = 675 \text{ }^\circ\text{C}$, $T_m = -15 \text{ }^\circ\text{C}$, common in soils and sediments, red beds

Pyrrhotite (Fe_7S_8):

$M_s = \sim 80 \text{ kA/m}$, $T_c = 320 \text{ }^\circ\text{C}$

Pyrrhotite (Fe_9S_{10}):

ferrimagnetic above $200 \text{ }^\circ\text{C}$, $T_c = 265 \text{ }^\circ\text{C}$ in sedimentary metamorphic rocks, sulfide ores

Greigite (Fe_3S_4):

$M_s = \sim 125 \text{ kA/m}$, $T_c = \sim 330 \text{ }^\circ\text{C}$

forms in aquatic environments (and soils) under unoxic conditions, in bacteria

Goethite ($\alpha\text{-FeOOH}$):

$M_s = \sim 2 \text{ kA/m}$, $T_c = 120 \text{ }^\circ\text{C}$

in soils and aquatic environments

Siderite (FeCO_3):

$T_N = -235 \text{ }^\circ\text{C}$ (antiferromagnetic, but paramagnetic at room temperature) marine lacustrine, in soils probably

Susceptibility of rocks and minerals

Magnetic susceptibility is an extremely important property of rocks, and is to magnetic exploration methods what density is to gravity surveys. Rocks that have a significant concentration of ferro- and/or ferrimagnetic minerals tend to have the highest susceptibilities. Consequently, basic and ultrabasic rocks have the highest susceptibilities, acidic igneous and metamorphic rocks have intermediate to low values, and sedimentary rocks have very low susceptibilities in general.

If the magnetic material has relatively large susceptibilities, or if the inducing field is strong, the magnetic material will retain a portion of its induced magnetization even after the induced field disappears. This remaining magnetization is called Remnant Magnetization.

Remnant Magnetization is the component of the material's magnetization that solid-earth geophysicists use to map the motion of continents and ocean basins resulting from plate tectonics. Rocks can acquire a remnant magnetization through a variety of processes (table below).

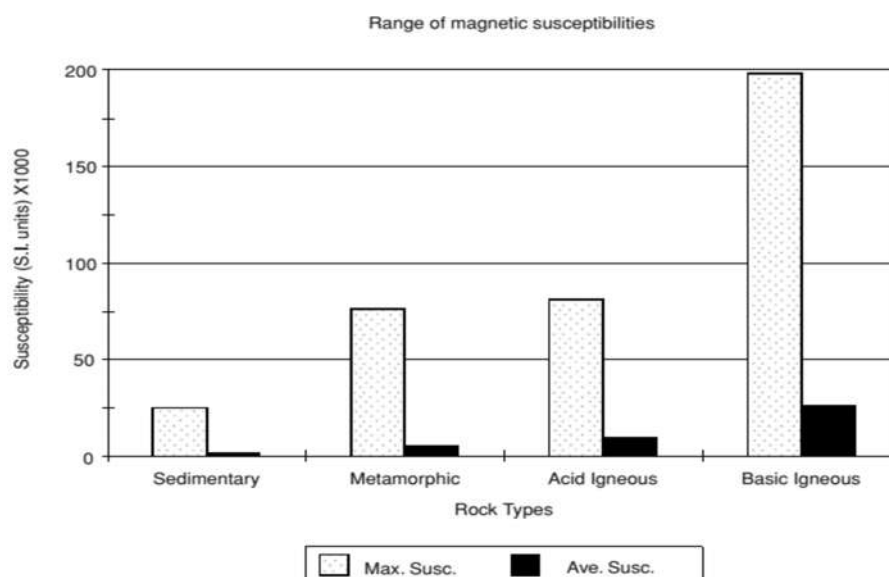

Material	Susceptibility x 10 ³ (SI)*
Air	~0
Quartz	-0.01
Rock Salt	-0.01
Calcite	-0.001 - 0.01
Sphalerite	0.4
Pyrite	0.05 - 5
Hematite	0.5 - 35
Illmenite	300 - 3500
Magnetite	1200 - 19,200
Limestones	0 - 3
Sandstones	0 - 20
Shales	0.01 - 15
Schist	0.3 - 3
Gneiss	0.1 - 25
Slate	0 - 35
Granite	0 - 50
Gabbro	1 - 90
Basalt	0.2 - 175
Peridotite	90 - 200

Types of magnetism

1. Induced magnetism

This is due to induction by the Earth's field, and is in the same direction as the Earth's field. Most magnetization is from this source. It is important to appreciate that since the Earth's field varies from place to place, the magnetic anomaly of a body will vary according to its location.

2. Remnant magnetism

This is due to the previous history of the rock. There are various types:

1. Chemical remnant magnetization (CRM)

This is acquired as a result of chemical grain accretion or alteration, and affects sedimentary and metamorphic rocks.

2. Detrital remnant magnetisation (DRM)

This is acquired as particles settle in the presence of Earth's field. The particles tend to orient themselves as they settle. 3. Isothermal remnant magnetism (IRM) This is the residual magnetic field left when an external field is applied and removed, e.g., lightning.

4. Thermo-remnant magnetisation (TRM)

This is acquired when rock cools through the Curie temperature, and characterizes most igneous rocks. It is the most important kind of magnetization for palaeomagnetic dating.

5. Viscous remnant magnetism (VRM)

Rocks acquire this after long exposure to an external magnetic field, and it may be important in fine-grained rocks. 4.3 Induced and remnant magnetism. The direction and strength of the present Earth's field is known. we may know nothing about the remnant magnetization of a rock. For this reason, and because in strongly magnetized rocks the induced field dominates, it is often assumed that all the magnetization is induced. The true magnetization is the vector sum of the induced and remnant components, however. The remnant magnetization be measured using an Astatic or Spinner magnetometer, which measure the magnetism of samples in the absence of the Earth's field.

Tabel. Types of remanent magnetisation (RM). After Merrill (1990)

Types of RM	Process
Natural (NRM)	Acquired by a rock or mineral under natural conditions.
Thermal (TRM)	Acquired by a material during cooling from a temperature greater than the Curie temperature to room temperature (e.g. molten lava cooling after a volcanic eruption).
Isothermal (IRM)	Acquired over a short time (of the order of seconds) in a strong magnetic field at a constant temperature (e.g. such as by a lightning strike).
Chemical (CRM)	Also crystallisation RM; acquired at the time of nucleation and growth or crystallisation of fine magnetic grains far below the Curie point in an ambient field.
Thermal-chemical (TCRM)	Acquired during chemical alteration and cooling.
Detrital (DRM)	Also depositional RM; acquired by the settling out of previously magnetised particles to form ultimately consolidated sediments which then have a weak net magnetisation, but prior to any chemical alteration through diagenetic processes.
Post-depositional (PDRM)	Acquired by a sediment by physical processes acting upon it after deposition (e.g. bioturbation and compaction).
Viscous (VMR)	Acquired after a lengthy exposure to an ambient field with all other factors being constant (e.g. chemistry and temperature).
Anhyseretic (ARM)	Acquired when a peak amplitude of an alternating magnetic field is decreased from a large value to zero in the presence of a weak but constant magnetic field.

The Earth's Magnetic Field

The magnetic field can be broken into **three separate components**:-

- 1- Main Magnetic Field - This is the largest component of the magnetic field and is believed to be caused by electrical currents in the Earth's fluid outer core. For exploration work, this field acts as the inducing magnetic field.
- 2- External Magnetic Field - This is a relatively small portion of the observed magnetic field that is generated from magnetic sources external to the earth. This field is believed to be produced by interactions of the Earth's ionosphere with the solar wind. Hence, temporal variations associated with the external magnetic field are correlated to solar activity.
- 3- The Crustal magnetic Field - This is the portion of the magnetic field associated with the magnetism of crustal. The Earth's Magnetic Field rocks. This portion of the field contains both magnetism caused by induction from the Earth's main magnetic field and from remnant magnetization

Components of the Earth's magnetic field.

At any point on the Earth's surface, the magnetic field, F , has some strength and points in some direction. The following terms are used to describe the direction of the magnetic field

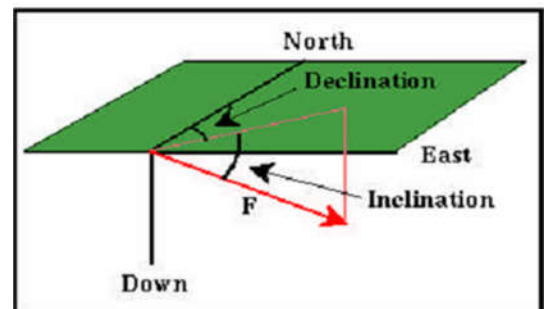

Declination - The angle between north and the horizontal projection of F . This value is measured positive through east and varies from 0 to 360 degrees .

Inclination - The angle between the surface of the earth and F and varies from -90 to 90 degree.

Magnetic Equator - The location around the surface of the Earth where the Earth's magnetic field has an inclination of zero (the magnetic field vector F is horizontal). This location does not correspond to the Earth's rotational equator.

Magnetic Poles - The locations on the surface of the Earth where the Earth's magnetic field has an inclination of either plus or minus 90

degrees (the magnetic field vector F is vertical). These locations do not correspond to the Earth's north and south poles.

Temporal Variations of the Earth's Magnetic Field

the magnetic field varies with time. When describing temporal variations of the magnetic field, it is useful to classify these variations into one of three types depending on their rate of occurrence and source.

Secular Variations - These are long-term (changes in the field that occur over years) variations in the main magnetic field that are presumably caused by fluid motion in the Earth's Outer Core. Because these variations occur slowly with respect to the time of completion of a typical exploration magnetic survey, these variations will not complicate data reduction efforts.

Diurnal Variations - These are variations in the magnetic field that occur over the course of a day and are related to variations in the Earth's external magnetic field. This variation can be on the order of 20 to 30 nT per day and should be accounted for when conducting exploration magnetic surveys.

Magnetic Storms - Occasionally, magnetic activity in the ionosphere will abruptly increase. The occurrence of such storms correlates with enhanced sunspot activity. The magnetic field observed during such times is highly irregular and unpredictable, having amplitudes as large as 1000 nT. Exploration magnetic surveys should not be conducted during magnetic storms.

Measuring the Earth's Magnetic Field

instruments for measuring aspects of the Earth's magnetic field are among some of the oldest scientific instruments in existence. Magnetometers - Magnetometers are instruments, usually operating non-mechanically, that are capable of measuring the strength, or a component of the strength, of the magnetic field. The first advances in designing these instruments were made during WWII when Fluxgate Magnetometers were developed for use in submarine detection. Since

that time, several other magnetometer designs have been developed that include the Proton Precession and Alkali-Vapor magnetometers.

Fluxgate Magnetometer

The fluxgate magnetometer was originally designed and developed during World War II. It was built for use as a submarine detection device for low-flying aircraft. Today it is used for conducting magnetic surveys from aircraft and for making borehole measurements. A schematic of the fluxgate magnetometer is shown below.

The fluxgate magnetometer is based on what is referred to as the magnetic saturation circuit. Two parallel bars of a ferromagnetic material are placed closely together. The susceptibility of the two bars is large enough so that even the Earth's relatively weak magnetic field can produce magnetic saturation* in the bars. Each bar is wound with a primary coil, but the direction in which

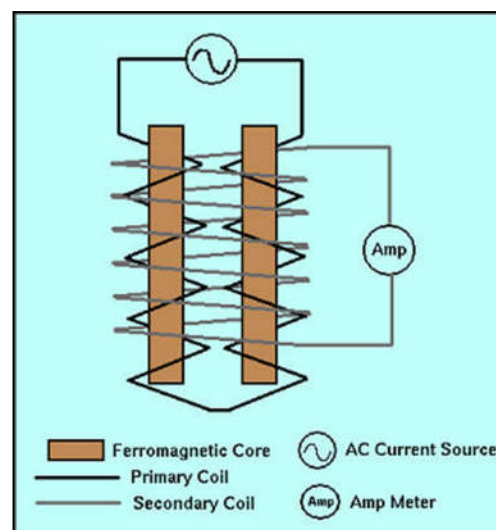

the coil is wrapped around the bars is reversed. An alternating current (AC) is passed through the primary coils causing a large, inducing magnetic field that produces induced magnetic fields in the two cores that have the same strengths but opposite orientations. A secondary coil surrounds the two ferromagnetic cores and the primary coil. The magnetic fields induced in the cores by the primary coil produce a voltage potential in the secondary coil. In the absence of an external field (i.e., if the earth had no magnetic field), the voltage detected in the secondary coil would be zero because the magnetic fields generated in the two cores have the same strength but are in opposite directions (their affects on the secondary coil exactly cancel). If the cores are aligned parallel to a component of a weak, external magnetic field, one core will produce a magnetic field in the same direction as the external field and reinforce it. The other will be in opposition to the field and produce an induced field that is smaller. This difference is sufficient to induce a measureable voltage in the secondary coil that is proportional

to the strength of the magnetic field in the direction of the cores. Thus, the fluxgate magnetometer is capable of measuring the strength of any component of the Earth's magnetic field by simply re-orienting the instrument so that the cores are parallel to the desired component. Fluxgate magnetometers are capable of measuring the strength of the magnetic field to about 0.5 to 1.0 nT.

Proton Precession Magnetometer

The sensor component is a cylindrical container filled with a liquid rich in hydrogen atoms surrounded by a coil. Commonly used liquids include water, kerosene, and alcohol. The sensor is connected by a cable to a small unit in which is housed a power supply, an electronic switch, an amplifier, and a frequency counter.

When the switch is closed, a DC current delivered by a battery is directed through the coil, producing a relatively strong magnetic field in the fluid-filled cylinder. The hydrogen nuclei (protons), which behave like minute spinning dipole magnets, become aligned along the direction of the applied field

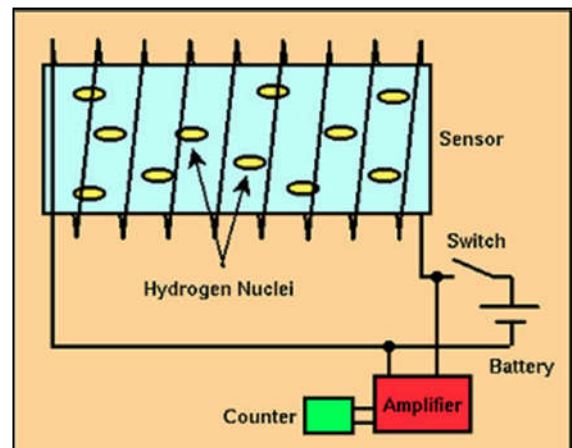

Because the Earth's magnetic field generates a torque on the aligned, spinning hydrogen nuclei, they begin to precess around the direction of the Earth's total field. This precession induces a small alternating current in the coil. The frequency of the AC current is equal to the frequency of precession of the nuclei. Because the frequency of precession is proportional to the strength of the total field and because the constant of proportionality is well known, the total field strength can be determined quite accurately

Box 3.7 Magnetic field strength, F , and precession frequency, f_p

$$F = 2\pi f_p / \Phi_p$$

where Φ_p is the gyromagnetic ratio of the proton, which is the ratio of the magnetic moment and spin angular momentum (see Figure 3.22); and

$$\Phi_p = 0.26753 \text{ Hz/nT and } 2\pi / \Phi_p = 23.4859 \text{ nT/Hz.}$$

Thus:

$$F = 23.4859 f_p$$

For example, for $F = 50,000 \text{ nT}$, $f_p = 2128.94 \text{ Hz}$.

Magnetic Anomaly: Magnetized Sphere at the North Pole ($I=90$)

the magnetic anomaly of a metallic sphere located beneath the north pole would look like. The geometry of the sphere, the Earth's main magnetic field, the field lines associated with the anomalous field, the direction and magnitude of the anomalous field, and a plot of the intensity of the anomalous field that would be recorded are shown.

At the north (magnetic) pole, the Earth's main magnetic field, F_e , points straight down. Because the buried sphere is composed of a material with a non-zero susceptibility, the Earth's main magnetic field causes the sphere to produce an induced magnetic field. Field lines associated with this induced field are shown by black lines, and the magnitude and direction of the induced, anomalous field, F_{ai} , at the surface of the earth are shown by the blue arrows.

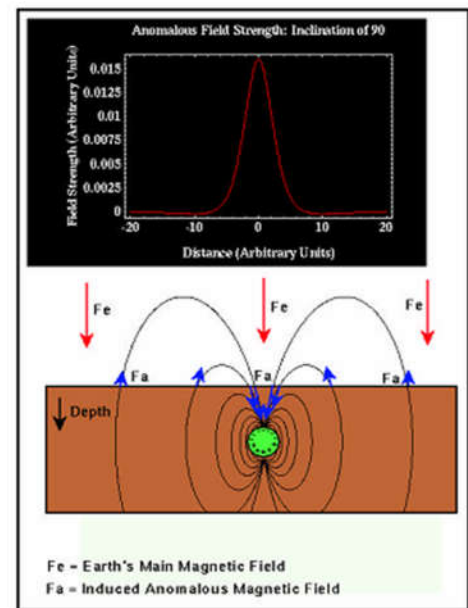

Magnetic Anomaly: Magnetized Sphere at the Equator ($I=0$)

At the equator (magnetic), the direction of the Earth's main magnetic field is now horizontal. It still induces an anomalous magnetic field in the metallic sphere, but the orientation of field lines describing the magnetic field are now rotated 90 degrees. Above the sphere, the anomalous magnetic field, F_a , now points in the opposite direction as the Earth's main magnetic field, F_e . Therefore, the total field measured will be less than the Earth's main field, and so upon removal of the main field, the resulting anomalous field will be negative. On either side of the sphere, the anomalous field points in the general direction of the main field and thus reinforces it resulting in total field measurements that are larger than the Earth's main field. Upon removal

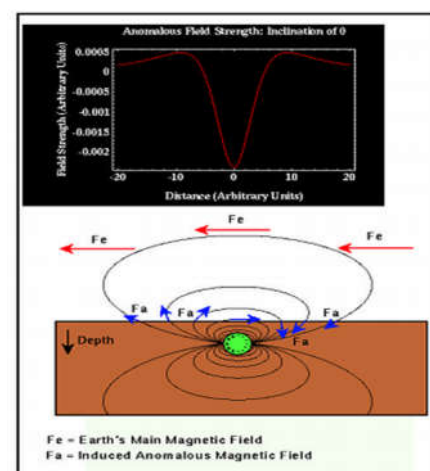

of the main field contribution, these areas will show positive magnetic anomalies.

Magnetic Anomaly: Magnetized Sphere in the Northern Hemisphere($I=45$)

the Earth's main magnetic field induces an anomalous field in surrounding the sphere. The anomalous field is now oriented at some angle, in this case 45 degrees, from the horizontal. By looking at the direction of the anomalous field, F_a , in comparison with the Earth's main field, F_e , you can see that there will be a small negative anomaly far to the south of the sphere, a large positive anomaly just south of the sphere, and a small, broad, negative anomaly north of the sphere. Notice that the magnetic anomaly produced is no longer symmetric about the sphere. Unless you are working in one of those special places, like at the magnetic poles or equator, this will always be true.

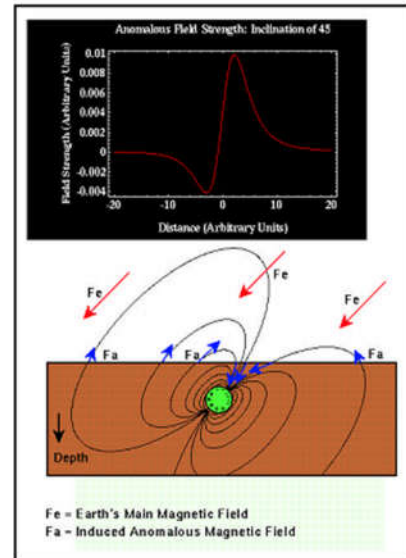

Magnetic survey

Magnetic Surveys

- **Land Magnetic Survey:** provide a great deal of information about the distribution of rocks occurring under thin layers of sedimentary rocks, useful when trying to **locate orebodies (minerals)**
- **Aeromagnetic Survey:** is fast, low cost and cover big areas. Give information about **depths of basement and sedimentary basins.**

A **G-856 magnetometer** is the instrument used to measure the **total magnetic intensity** with resolution (0.1) nT

G-856 Proton Magnetometer





- **Marine Magnetic Survey:** It is used in lakes, seas and oceans to locate structures (**fault, dike**) and **minerals**

A **G-882 Marine Magnetometer**
The model **G-882 cesium-vapor marine** magnetometer provides the same **high performance** as our **airborne instruments** delivering **high resolution** results in all types of survey applications.

The data for a survey can be plotted as a **contour map** using lines which join points of equal "magnetic" value. From **magnetic maps** can locate **magnetic bodies** and interpret as the nature of geological boundaries at **depth**, find **faults** etc.

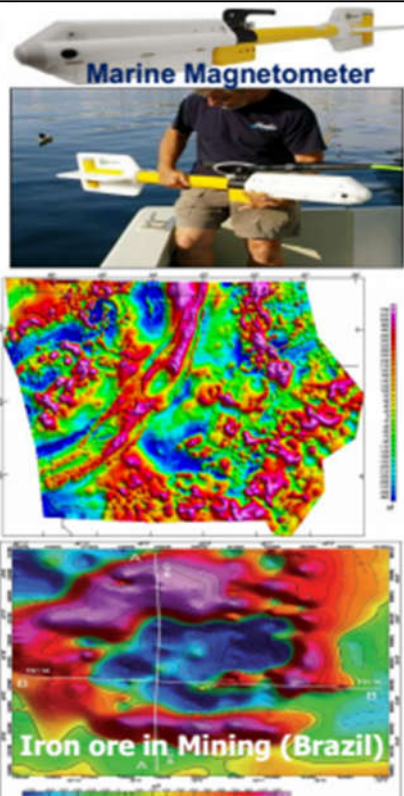

Similarities Between Gravity and Magnetics

- Geophysical exploration techniques that employ both gravity and magnetics are passive. By this, we simply mean that when using these two methods we measure a naturally occurring field of the earth: either the earth's gravitational or magnetic fields. Collectively, the gravity and magnetics methods are often referred to as potential methods*, and the gravitational and magnetic fields that we measure are referred to as potential fields.
- Identical physical and mathematical representations can be used to understand magnetic and gravitational forces. Mathematical representations for the point mass and the magnetic monopole are identical.
- The acquisition, reduction, and interpretation of gravity and magnetic observations are very similar

Differences Between Gravity and Magnetics

	Gravity Method	Magnetic Method
1	The fundamental parameter that controls gravity variations of interest is rock density	the fundamental parameter controlling the magnetic field variations of interest is, magnetic susceptibility
2	the gravitational force, which is always attractive	the magnetic force can be either attractive or repulsive
3	A properly reduced gravitational field is always generated by subsurface variations in rock density	A properly reduced magnetic field is generated by an induced magnetization, or remnant magnetization.
4	the gravitational field, which does not change significantly with time	the magnetic field is highly time dependent.

Electrical Methods

General

Electrical geophysical methods have been used for many decades in:-

- hydrogeological,
- Petroleum,
- mining and
- geotechnical investigations.

More recently, it has been used for environmental and engineering problems.

Classification of Electrical Geophysical Methods

Electrical Geophysical Methods include:-

1. Self-Potential (SP),
2. telluric currents and magnetotellurics (MT)
3. Resistivity, (DC resistivity)
4. Equipotential and mise-à-la-masse,(MALM)
5. Electromagnetic (EM), and
6. Induced Polarization (IP).

1. According to the type of energy source

Electrical Geophysical Methods classified into natural(1 &2) or artificial (the rest) energy sources.

2. According to domains of measurement data

A. Time Domain Methods (TDEM or TEM):-

are those in which the magnitude only or magnitude and shape of the received signal is measured, Techniques in this class are discussed under the headings of; DC resistivity, induced polarization, time-domain electromagnetic, and self-potential.

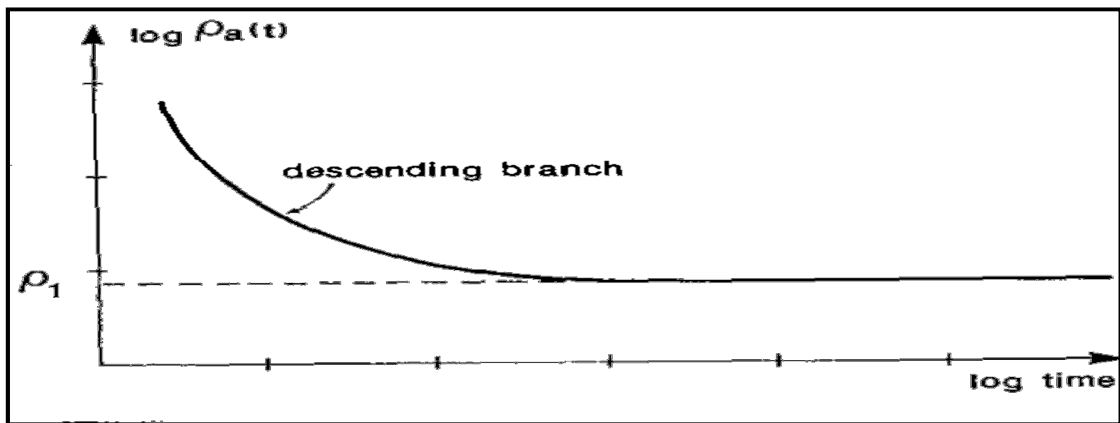

B. Frequency Domain Methods (FDEM or FEM)

are those in which the frequency content of the received signal is measured. Generally FDEM methods are continuous source methods, and measurements are made while the source is on. The measurement is of magnitude at a given frequency. Techniques in this class are discussed under the headings of VLF, terrain conductivity, and metal detectors.

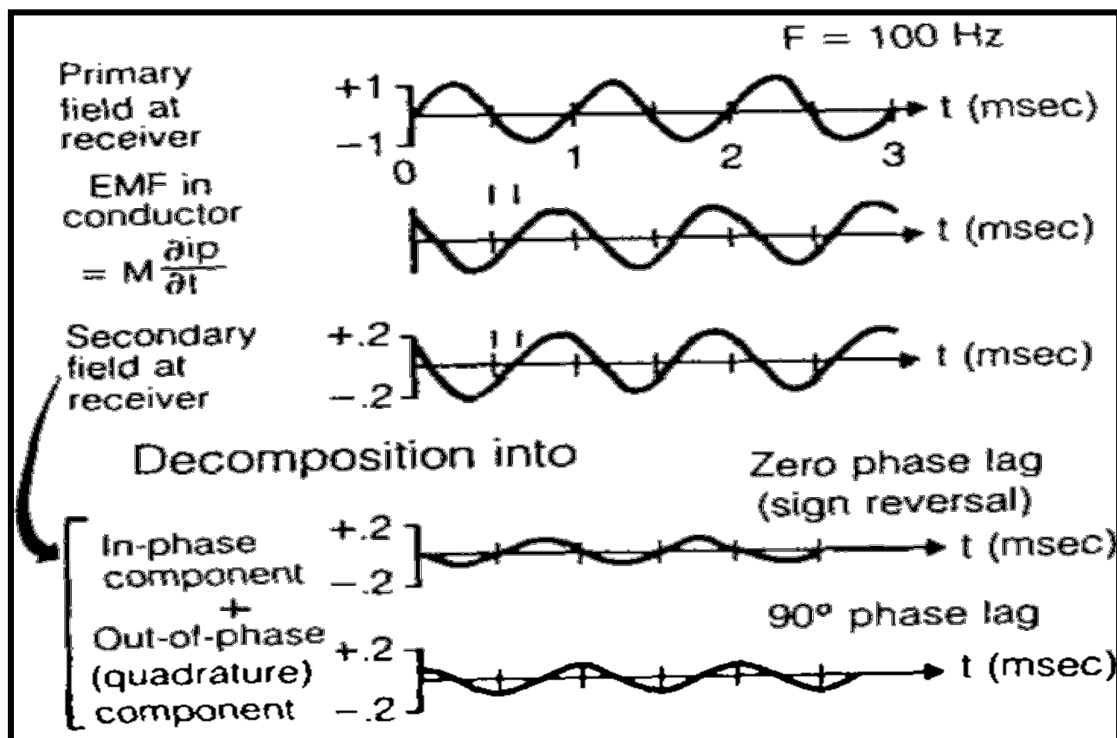

1-DC- Resistivity Method

Resistivity Method -Observation of electric fields caused by current introduced into the ground as a means of studying earth resistivity in geophysical exploration. Resistivity is the property of a material that resists the flow of electrical current.

The relationship between the current and potential distribution is described by Ohm's law: $V = IR$

V = difference of potential between two points on the wire.

I = current through the wire

R = resistance measured between the same two points as the difference of potential.

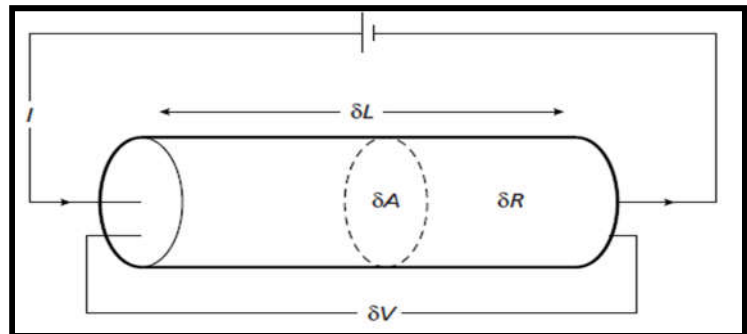

The resistance (R) of a length of wire is given by

$$R = \rho \frac{L}{A}$$

Electrical properties of rocks .

- ❖ Parameters that affect the resistivity of a soil or rock include porosity, water content, composition (clay mineral and metal content), salinity of the pore water, and grain size distribution.
- ❖ Variations in the resistivity of earth materials, either vertically or laterally, produce variations in the relations between the applied current and the potential distribution as measured on the surface.
- ❖ In most earth materials, the conduction of electric current takes place virtually entirely in the water occupying the pore spaces or joint openings, since most soil- and rock-forming minerals are essentially nonconductive.
- ❖ Clays and a few other minerals, notably magnetite, hematite, carbon, pyrite, and other metallic sulfides, may be found in sufficient concentration to contribute measurably to the conductivity of the soil or rock.

- ❖ Water, in a pure state, is virtually nonconductive but forms a conductive electrolyte with the presence of chemical salts in solution, and the conductivity is proportional to the salinity.
- ❖ The effect of increasing temperature is to increase the conductivity of the electrolyte. When the pore water freezes, there is an increase in resistivity.
- ❖ Electrical resistivity surveys made on frozen ground are likely to encounter difficulties because of the high resistivity of the frozen surface layer and high contact resistance at the electrodes.
- ❖ The effect of freezing on resistivity makes the resistivity method very useful in determining the depth of the frozen layer.
- ❖ The conduction of current in soil and rock is through the electrolyte contained in the pores, resistivity is governed largely by the porosity.

The relationship between geology and resistivity

Material	Resistivity ($\Omega \cdot m$)	Conductivity (Siemen/m)
Igneous and Metamorphic Rocks		
Granite	$5 \times 10^3 - 10^6$	$10^{-6} - 2 \times 10^{-4}$
Basalt	$10^3 - 10^6$	$10^{-6} - 10^{-3}$
Slate	$6 \times 10^2 - 4 \times 10^7$	$2.5 \times 10^{-8} - 1.7 \times 10^{-3}$
Marble	$10^2 - 2.5 \times 10^8$	$4 \times 10^{-9} - 10^{-2}$
Quartzite	$10^2 - 2 \times 10^8$	$5 \times 10^{-9} - 10^{-2}$
Sedimentary Rocks		
Sandstone	$8 - 4 \times 10^3$	$2.5 \times 10^{-4} - 0.125$
Shale	$20 - 2 \times 10^3$	$5 \times 10^{-4} - 0.05$
Limestone	$50 - 4 \times 10^2$	$2.5 \times 10^{-3} - 0.02$
Soils and waters		
Clay	1 - 100	0.01 - 1
Alluvium	10 - 800	$1.25 \times 10^{-3} - 0.1$
Groundwater (fresh)	10 - 100	0.01 - 0.1
Sea water	0.2	5
Chemicals		
Iron	9.074×10^{-8}	1.102×10^7
0.01 M Potassium chloride	0.708	1.413
0.01 M Sodium chloride	0.843	1.185
0.01 M acetic acid	6.13	0.163
Xylene	6.998×10^{16}	1.429×10^{-17}

- ❖ Igneous and metamorphic rocks typically have high resistivity values. The resistivity of these rocks is greatly dependent on the degree of fracturing, and the percentage of the fractures filled with ground water.

- ❖ Sedimentary rocks, which usually are more porous and have a higher water content, normally have lower resistivity values. Wet soils and fresh ground water have even lower resistivity values. Clayey soil normally has a lower resistivity value than sandy soil.
- ❖ The resistivity method an ideal technique for mapping the saline and fresh water interface in coastal areas
- ❖ Metals, such as iron, have extremely low resistivity values.
- ❖ Chemicals which are strong electrolytes, such as potassium chloride and sodium chloride, can greatly reduce the resistivity of ground water to less than 1 ohm even at fairly low concentrations. The effect of weak electrolytes, such as acetic acid, is comparatively smaller.
- ❖ Hydrocarbons, such as xylene, typically have very high resistivity values.

Electrode (arrays) Configurations

The purpose of electrical surveys is to determine the subsurface resistivity distribution by making measurements on the ground surface.

The resistivity measurements are normally made by injecting current into the ground through two current electrodes (C1 and C2 ,and the resulting voltage difference at two potential electrodes (P1 and P2).

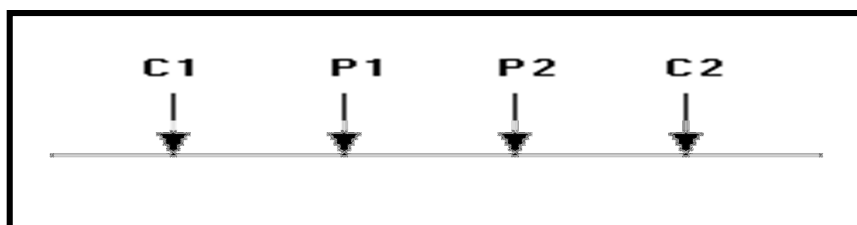

From the current (I) and voltage (V) values, an apparent resistivity (ρ_a) value is calculated $\rho_a = k V / I$

where **k** is the **geometric factor** which depends on the arrangement of the four electrodes.

For a current source and sink, the potential V_P at any point P in the ground is equal to the sum of the voltages from the two electrodes, such that: $V_P = V_A + V_B$ where V_A and V_B are the potential contributions from the two electrodes, $A(+I)$ and $B(-I)$.

The potentials at electrode M and N are:

$$V_M = \frac{\rho I}{2\pi} \left[\frac{1}{AM} - \frac{1}{MB} \right], \quad V_N = \frac{\rho I}{2\pi} \left[\frac{1}{AN} - \frac{1}{NB} \right]$$

However, it is far easier to measure the potential difference, δV_{MN} which can be rewritten as:

$$\rho V_{MN} = V_M - V_N = \frac{\rho I}{2\pi} \left\{ \left[\frac{1}{AM} - \frac{1}{MB} \right] - \left[\frac{1}{AN} - \frac{1}{NB} \right] \right\}$$

Rearranging this so that resistivity ρ is the subject:

$$\rho = \frac{2\pi \rho V_{MN}}{I} \left\{ \left[\frac{1}{AM} - \frac{1}{MB} \right] - \left[\frac{1}{AN} - \frac{1}{NB} \right] \right\}^{-1}$$

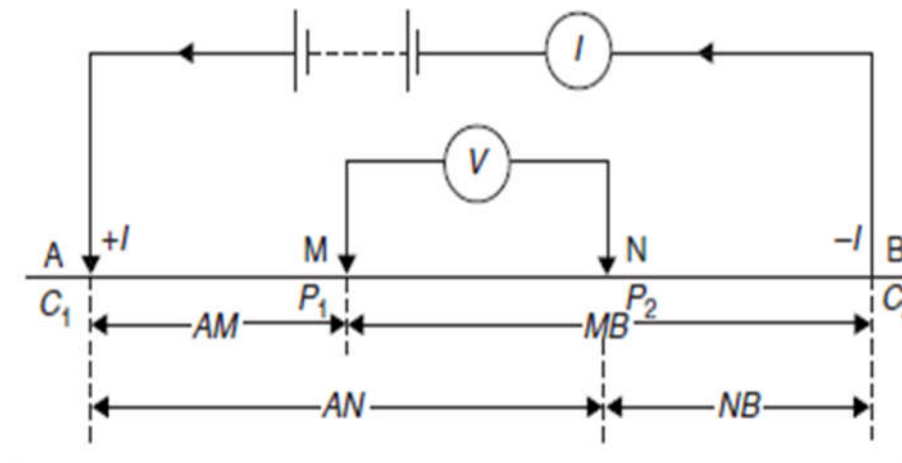

The geometric factor (K) is defined by the expression:

$$K = 2\pi \left(\frac{1}{AM} - \frac{1}{MB} - \frac{1}{AN} + \frac{1}{NB} \right)$$

Where the ground is not uniform, the resistivity so calculated is called the apparent resistivity (ρ_a):

$$\rho_a = R K, \text{ where } R = \delta V/I.$$

Geometrical Factors

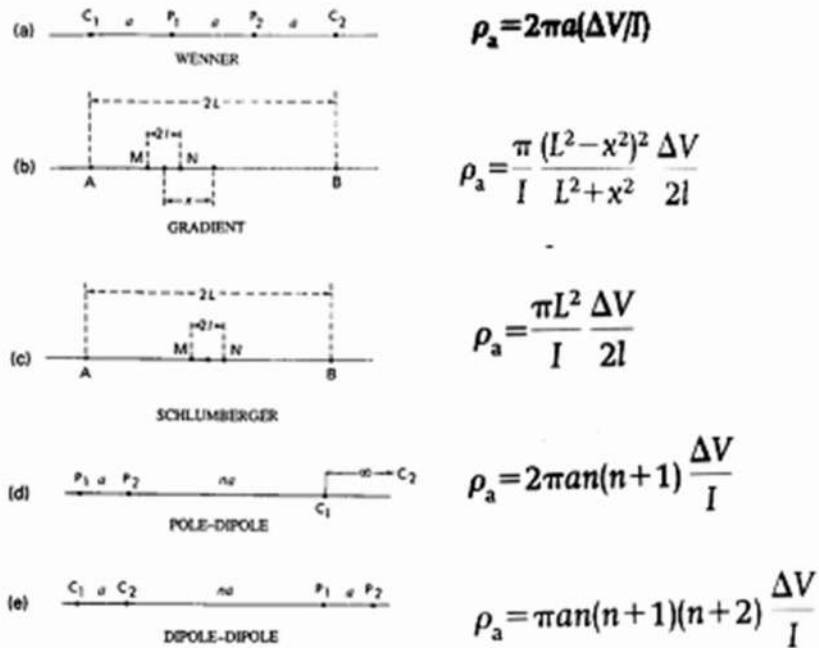

Array advantages and disadvantages

Array	Advantages	Disadvantages
Wenner	<ol style="list-style-type: none"> 1. Easy to calculate ρ_a in the field 2. Less demand on instrument sensitivity 	<ol style="list-style-type: none"> 1. All electrodes moved each sounding 2. Sensitive to local shallow variations 3. Long cables for large depths
Schlumberger	<ol style="list-style-type: none"> 1. Fewer electrodes to move each sounding 2. Needs shorter potential cables 	<ol style="list-style-type: none"> 1. Can be confusing in the field 2. Requires more sensitive equipment 3. Long Current cables
Dipole-Dipole	<ol style="list-style-type: none"> 1. Cables can be shorter for deep soundings 	<ol style="list-style-type: none"> 1. Requires large current 2. Requires sensitive instruments

Factors controlling the choice of the electrode arrays:-

The choice of the “best” array for a field survey depends on:-

- (1) the sensitivity of the array to vertical and horizontal changes in the subsurface resistivity,
- (2) the depth of investigation (depth penetration),
- (3) the horizontal data coverage and
- (4) the signal strength.

Vertical Electrical Sounding (VES)

The variation of resistivity with depth, reflecting more or less horizontal stratification of earth materials; and .This procedure is sometimes called Vertical Electrical Sounding (VES), or vertical profiling. As the distance between the current electrodes is increased, so the depth to which the current penetrates is increased.

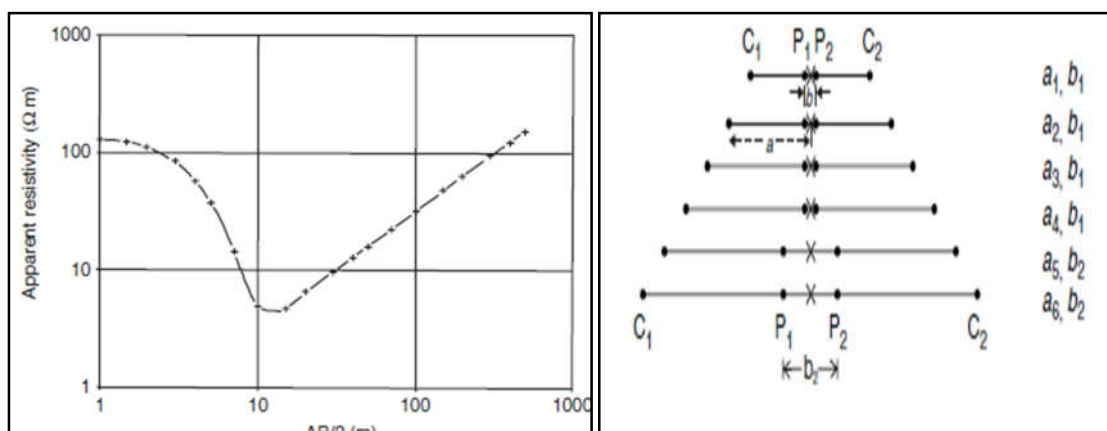

In the case of the Schlumberger array ,the potential electrodes (P1-P2) are placed at a fixed spacing (b) which is no more than a fifth of the current-electrode half-spacing (a). The current electrodes are placed at progressively larger distances. When the measured voltage between P1 and P2 falls to very low values (owing to the progressively decreasing potential gradient with increasing current electrode separation), the potential electrodes are spaced more widely apart (spacing b_2).

Constant separation traversing (CST)

Constant separation traversing (CST) or profiling method is the second approach employed in classical resistivity surveys, where the electrode separation remains fixed both in dimension and in orientation. The entire array is progressively moved along a straight line usually in the direction perpendicular to the geologic strike. This gives lateral variations in the subsurface resistivity at an approximate constant depth and is incapable of detecting vertical variations in the subsurface resistivity. Data obtained from profiling are mainly interpreted qualitatively. The Wenner configuration is best suited for this approach due to the equidistant spacing between the electrodes. For special problems, such as the determination of a steeply dipping structure or the precise determination of a fault, the dipole-dipole array is preferred. Generally, the gradient array could be a good choice in electrical resistivity profiling because only the potential electrodes need to be moved.

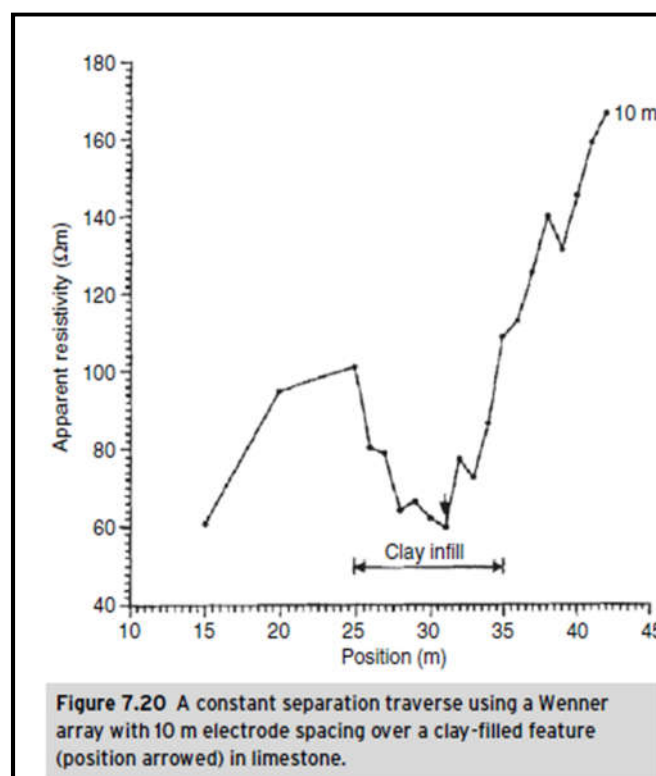

The Sensitivity of the array

Sensitivity is a reasonable quantity in electrical resistivity data interpretation process. It captures the changes in the potential due to changes in resistivity of a cell volume

The sensitivity function basically tells us the degree to which a change in the resistivity of a section of the subsurface will influence the potential measured by the array.

The higher the value of the sensitivity function, the greater is the influence of the subsurface region on the measurement.

Note that for all the three arrays, the highest sensitivity values are found near the electrodes.

At larger distances from the electrodes, the contour patterns are different for the different arrays.

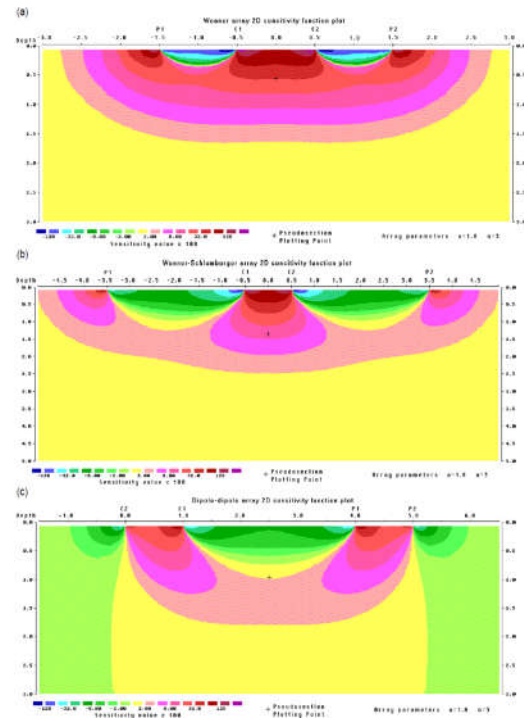

The depth of Penetration

The median depth of investigation gives an idea of the depth to which we can map with a particular array.

The median depth values are determined by integrating the sensitivity function with depth.

The sensitivity function:-

a- electrodes separation

(x, y, z) indicates the location of the small volume being subject to the resistivity change (as shown in Figure)

$$F_{ID}(z) = \frac{1}{4\pi^2} \int_{-\infty}^{+\infty} \int_{-\infty}^{+\infty} \frac{x(x-a) + y^2 + z^2}{[x^2 + y^2 + z^2]^{1.5} [(x-a)^2 + y^2 + z^2]^{1.5}} dx dz$$

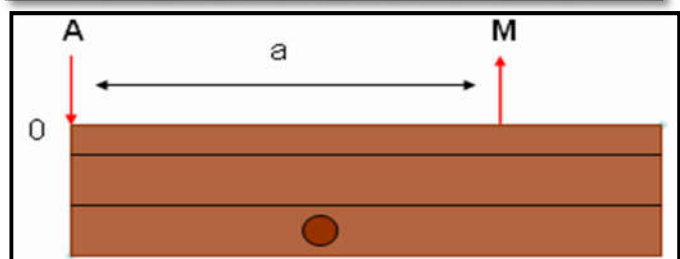

The depth of investigation:-

$$F_{ID}(z) = \frac{2}{\pi} \cdot \frac{z}{(a^2 + 4z^2)^{1.5}}$$

The median depth of investigation (ze) for the different arrays (after Edwards1977)

Array type	z_e/a	z_e/L	Geometric Factor	Inverse Geometric Factor (Ratio)
Wenner Alpha	0.519	0.173	6.2832	0.15915 (1.0000)
Wenner Beta	0.416	0.139	18.850	0.05305 (0.3333)
Wenner Gamma	0.594	0.198	9.4248	0.10610 (0.6667)
Dipole-dipole				
n = 1	0.416	0.139	18.850	0.05305 (0.3333)
n = 2	0.697	0.174	75.398	0.01326 (0.0833)
n = 3	0.962	0.192	188.50	0.00531 (0.0333)
n = 4	1.220	0.203	376.99	0.00265 (0.0166)
n = 5	1.476	0.211	659.73	0.00152 (0.0096)
n = 6	1.730	0.216	1055.6	0.00095 (0.0060)
n = 7	1.983	0.220	1583.4	0.00063 (0.0040)
n = 8	2.236	0.224	2261.9	0.00044 (0.0028)
Equatorial dipole-dipole				
n = 1	0.451	0.319	21.452	0.04662 (0.2929)
n = 2	0.809	0.362	119.03	0.00840 (0.0528)
n = 3	1.180	0.373	367.31	0.00272 (0.0171)
n = 4	1.556	0.377	841.75	0.00119 (0.0075)
Wenner - Schlumberger				
n = 1	0.519	0.173	6.2832	0.15915 (1.0000)
n = 2	0.925	0.186	18.850	0.05305 (0.3333)
n = 3	1.318	0.189	37.699	0.02653 (0.1667)
n = 4	1.706	0.190	62.832	0.01592 (0.1000)
n = 5	2.093	0.190	94.248	0.01061 (0.0667)
n = 6	2.478	0.191	131.95	0.00758 (0.0476)
n = 7	2.863	0.191	175.93	0.00568 (0.0357)
n = 8	3.247	0.191	226.19	0.00442 (0.0278)
n = 9	3.632	0.191	282.74	0.00354 (0.0222)
n = 10	4.015	0.191	345.58	0.00289 (0.0182)
Pole-dipole				
n = 1	0.519		12.566	0.07958 (0.5000)
n = 2	0.925		37.699	0.02653 (0.1667)
n = 3	1.318		75.398	0.01326 (0.0833)
n = 4	1.706		125.66	0.00796 (0.0500)
n = 5	2.093		188.50	0.00531 (0.0334)
n = 6	2.478		263.89	0.00379 (0.0238)
n = 7	2.863		351.86	0.00284 (0.0178)
n = 8	3.247		452.39	0.00221 (0.0139)
Pole-Pole				
	0.867		6.28319	0.15915 (1.0000)

The signal strength

The signal-to-noise ratio of an array would depend on whether the potential electrodes are placed within or outside the current electrodes. The potential difference and the signal strength would be higher for potential electrodes placed within the current electrodes than those placed outside the current electrodes. The geometric factor of an array is indirectly related to its signal strength; it reflects the range of potential differences to be expected for a particular electrode configuration. Low values of geometric factor indicate that high potential difference would be observed and vice versa. This implies that electrode configurations with low geometric factor will yield high signal-to-noise ratio.

The geometric factor for the various arrays for an "a" spacing of 1.0 meter. The inverse of the geometric factor gives an indication of the voltage that would be measured between the P1 and P2 potential electrodes. The ratio of this potential compared to the Wenner alpha array is also given, for example a value of 0.01 means that the potential is 1% of the potential measured by the Wenner alpha array with the same "a" spacing.

The signal strength is inversely proportional to the geometric factor used to calculate the apparent resistivity value for the array.

For the Wenner array, the geometric factor is $2\pi a$, which is smaller than the geometric factor for other arrays, the Wenner array has the strongest signal strength. This can be an important factor if the survey is carried in areas with high background noise

For example:-

1- if the maximum electrode "a" spacing used by the Wenner array is 100 metres, then the maximum depth mapped is about 51 metres.

2- if a dipole-dipole survey uses a maximum value of 10 meters for "a" and a corresponding maximum value of 6 for (n), then the maximum "L" value is 80 metres. This gives a maximum depth of investigation of 80×0.216 or about 17 metres.

2- Spontaneous (Self) Potential(SP) Methods

Natural potentials occur about dissimilar materials, near varying concentrations of electrolytic solutions, and due to the flow of fluids.

Spontaneous potentials can be produced by mineralization differences, electrochemical action, geothermal activity, and bioelectric generation of vegetation .

Applications of SP

Mineral exploration, flow of gasses and fluids in pipes, leakage of a reservoir within the foundation or abutment of a dam, groundwater and geothermal investigations, geological mapping, (to delineate shear zones and near-surface faults).

Types of electrical potentials

1- Electrokinetic, or streaming, potential is due to the flow of a fluid with certain electrical properties passing through a pipe or porous medium with different electrical properties.

2-Liquid-junction, or diffusion, potential is caused by the displacement of ionic solutions of dissimilar concentrations, **or** due to the differences in the mobility of electrolytes having different concentrations within groundwater.

3-Nernst, or shale, potential occurs when similar conductors have a solution of differing concentrations about them.

4- Mineralization, or electrolytic contact, potential is produced at the surface of a conductor with another medium.

Electrokinetic:

$$E_k = \frac{\epsilon \mu C_E \delta P}{4\pi \eta}$$

where ϵ , μ and η are the dielectric constant, resistivity and dynamic viscosity of the electrolyte respectively; δP is the pressure difference; and C_E is the electrofiltration coupling coefficient.

Diffusion potential:

$$E_d = \frac{-RT(I_a - I_c)}{nF(I_a + I_c)} \ln(C_1/C_2)$$

where: I_a and I_c are the mobilities of the anions (+ve) and cations (-ve) respectively; R is the Universal Gas Constant (8.314 J K⁻¹ mol⁻¹); T is absolute temperature (K); n is ionic valence; F is Faraday's Constant (96487 C mol⁻¹); C_1 and C_2 are the solution concentrations.

Nernst potential:

$$E_N = \frac{-RT}{nF} \ln(C_1/C_2)$$

when $I_a = I_c$ in the diffusion potential equation.

Non-polarizing electrodes

The electrodes in contact with the ground surface should be the non-polarizing type, also called porous pots.

Porous pots are metal electrodes suspended in a supersaturated solution of their own salts (such as a copper electrode suspended in copper sulfate) within a porous container.

These pots produce very low electrolytic contact potential, such that the background

voltage is as small as possible. Tinker and Rasor manufacture models of porcelain non-polarizing electrodes that are reliable and sealed to avoid evaporation of the salt solution

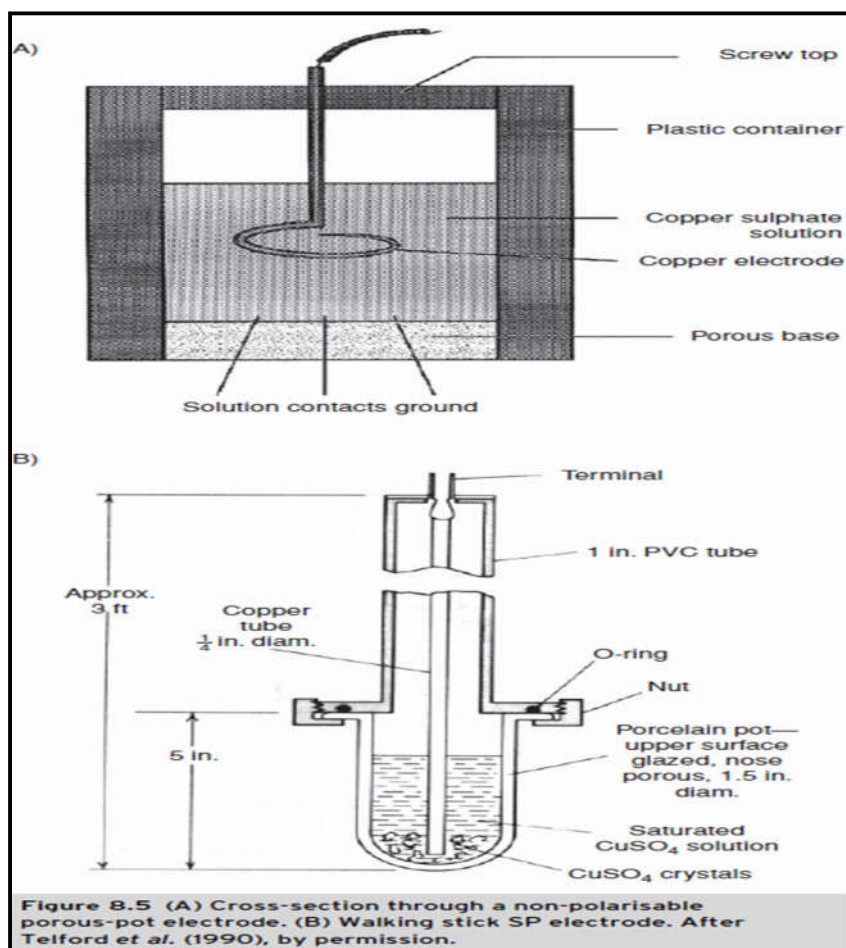

Types of SP anomalies and their geological sources

Source	Type of anomaly
<i>Mineral potentials</i>	
Sulphide ore bodies (pyrite, chalcopyrite, pyrrhotite, sphalerite, galena)	} Negative \approx hundreds of mV
Graphite ore bodies	
Magnetite + other electronically conducting minerals	
Coal	
Manganese	
Quartz veins	} Positive \approx tens of mV
Pegmatites	
<i>Background potentials</i>	
Fluid streaming, geochemical reactions, etc.	Positive +/- negative \leq 100 mV
Bioelectric (plants, trees)	Negative, \leq 300 mV or so
Groundwater movement	Positive or negative, up to hundreds of mV
Topography	Negative, up to 2 V

3-Mise-a-la-masse (MALM) Method

- is 'charged-body potential' method "excitation of the mass,"
- is still used in mining exploration and occasionally in geotechnical applications, in groundwater investigations, in hydropower investigations, examine groundwater flow in the proposed location of a new dam (Pant, personal communication).
- describes an electrode array which uses the conductive mass under investigation as one of the current electrodes(C1).
- In mining, the conductive mass is a mineral body exposed in a pit or drill hole.
- In geotechnical applications the object under investigation might be one end of an abandoned metal waste pipe.

- The second current electrode (C2) is placed a large distance away. "Large" usually means five or ten times the size of the mass being investigated.

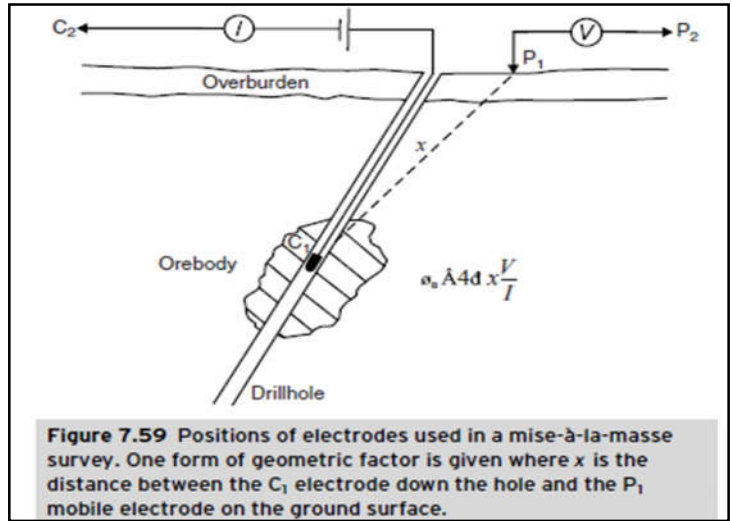

The potential distribution from these two current electrodes will, to some extent, reflect the geometry of the conductive mass and would be expected to yield some information concerning the shape and extent of the body.

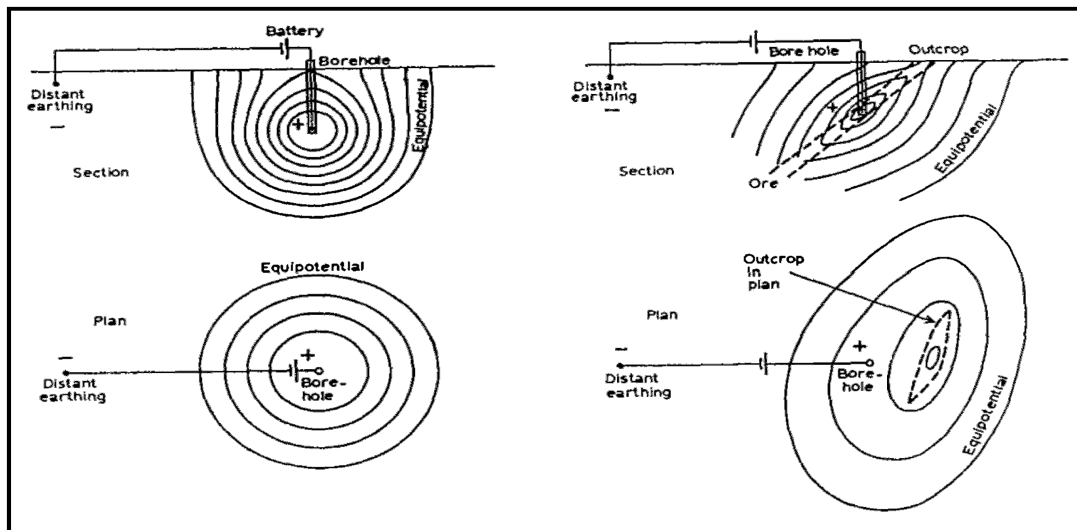

Principle of the mise-a-la-masse method. Right side of figure shows the distortion of the equipotential lines due to a conductive ore body (Parasnis 1973; copyright permission granted by Elsevier Science).

Examples

- 1- Abandoned ammunition magazine. Distortion of the equipotential lines clearly outlines the magazine
- 2- Advance of groundwater from an infiltration pit
- 3- partially exposed buried conductors

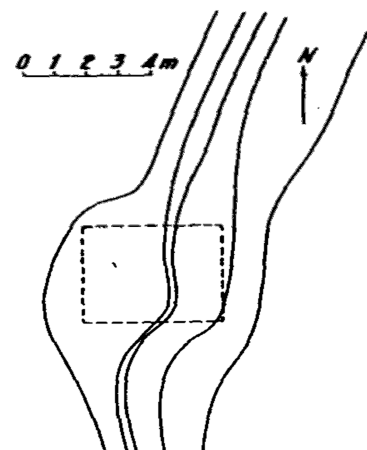

4-Induced Polarization (IP) Method

It is known as the *overvoltage effect* called “provoked polarization”.

The main current applications of IP prospecting:-

1-the search for disseminated metallic ores, especially porphyry coppers, bed-lead/zinc and sulphide-related gold deposits,

2-groundwater and geothermal exploration,

3-environmental applications, archaeological Investigations, and

4-the detection of organic contaminants.

The induced polarization phenomenon

The potential difference, measured between the potential electrodes, often did not drop instantaneously to zero when the current was turned off. Instead, the potential difference dropped sharply at first, then gradually decayed to zero after a given interval of time.

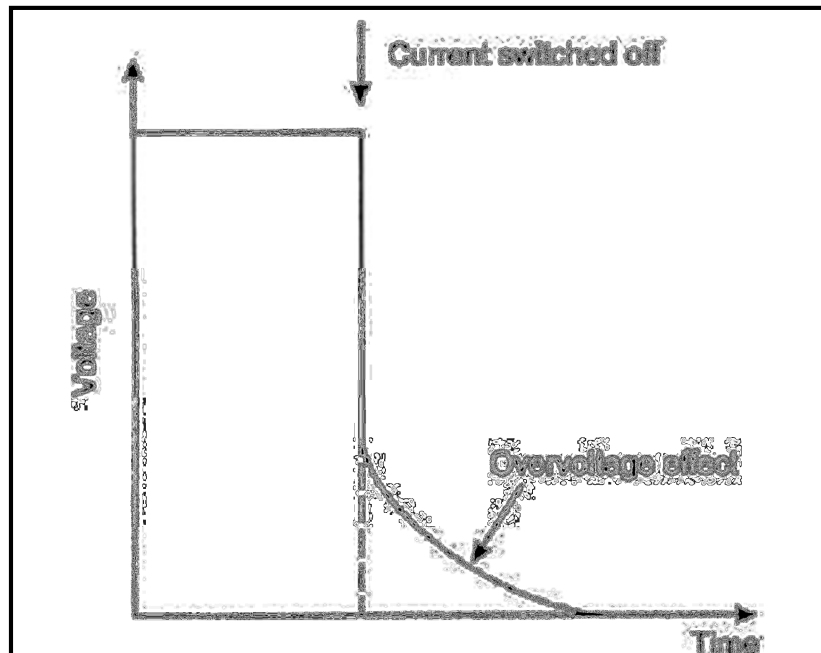

The overvoltage effect produced by induced polarization after applied current is switched off.

The origin of Induced Polarization

The two main mechanisms explain induced polarization.

1- Grain (electrode) polarization (overvoltage)

If a metal electrode is placed in an ionic solution without a voltage being applied, charges with different polarities separate, resulting in the establishment of a potential difference between the electrode and the solution.

When a voltage is applied, the ionic balance is disturbed; this causes a current to flow, which in turn changes the potential difference between the electrode and the solution. When the applied voltage is removed, the ionic balance is restored by the diffusion of ions. In the geological situation

current is conducted through the rock mass by the movement of ions within groundwater passing through interconnected pores or through the fracture and micro-crack structure within the rock.

When an electronically conducting grain (e.g. a metal sulphide) blocks a flow channel, charge builds up as in the electrochemical cell, the current flow and the grain becomes polarized, so creating a potential difference across the grain.

Mineral grains that become polarized, complete zones with significant concentrations of ore will also take on a net polarization. current polarizes the zone of ore concentration which, when the applied current is turned off, generates the transient polarization current that is measured at the surface.

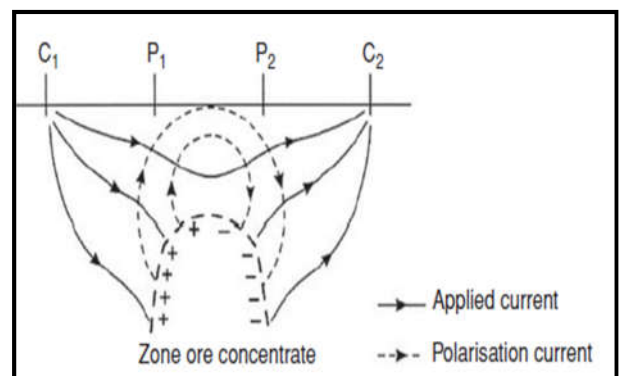
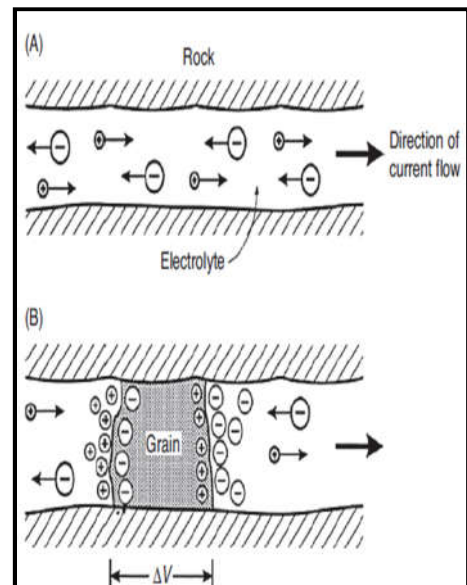
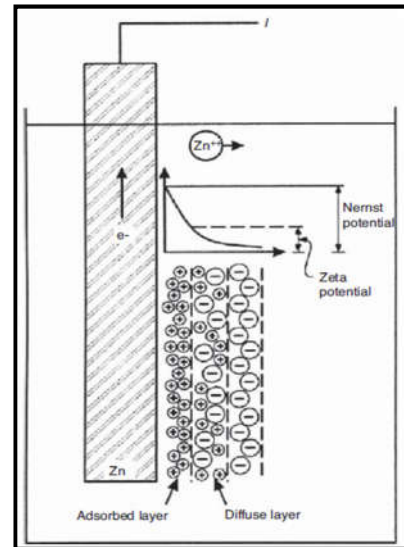

Bornite, cassiterite, chalcopyrite, galena, graphite, ilmenite, agnetite, pyrite, pyrolusite and pyrrhotite all exhibit strong IP responses as they have high electronic conductivities. The sulphides sphalerite, cinnabar and stibnite have low electronic conductivities and do not produce significant IP responses.

2- Membrane (electrolytic) polarization

There are two causes of membrane or electrolytic polarization.

A-Constriction within a pore channel,

B- Associated with the presence of clay within pore channels, such as in an impure sandstone.

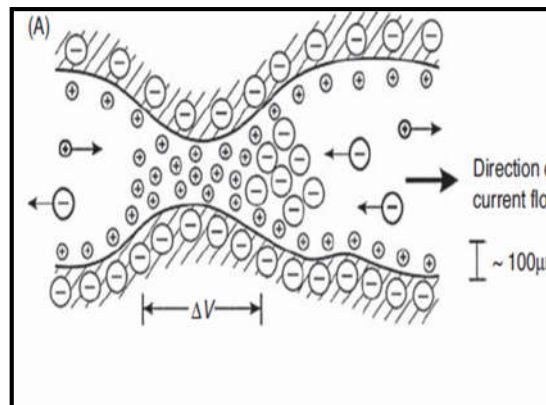

A- the constriction will block the flow of ions when a voltage is applied. Negative ions will leave the constricted zone and positive ions will increase their concentration, so producing a potential difference across the blockage. When the applied voltage is switched off, the imbalance in ionic concentration is returned to normal by diffusion, which produces the measured IP response.

B- the presence of clay particles or filaments of fibrous minerals,

both of which tend to have a net negative charge. Positive ions are attracted to them, producing a positively charged cloud within the pore space. When a voltage is applied, positive charges can move between these similarly charged clouds, but the negatively charged ions are blocked, which produces a difference in ionic concentration. When the applied voltage is switched off, the imbalances in ionic concentration decay to normal levels by diffusion, so causing a measurable IP response.

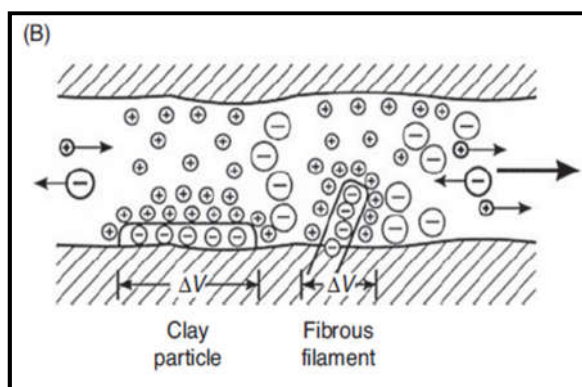

“chargeability M ”(in seconds) as the ratio of the area under the decay curve (in millivolt-seconds, mV-s) to the potential difference (in mV) measured before switching the current off (Seigel 1959).

Chargeability:

$$M = V_p / V_o \text{ (mV/V or \%)}$$

where V_p is the overvoltage, and V_o the observed voltage with an applied current.

Apparent chargeability:

$$M_a = \frac{1}{V_o} \int_{t_1}^{t_2} V_p(t) dt = \frac{A}{V_o}$$

where $V_p(t)$ is the overvoltage at time t , and the other terms are as defined in Figure 9.6B.

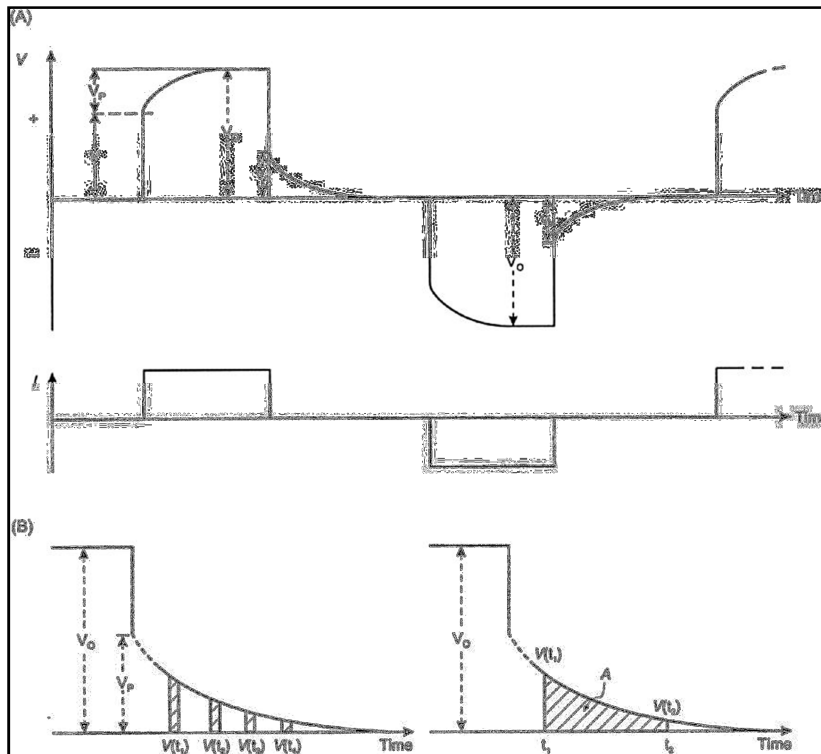

5-Magnetotellurics (MT) Methods

MT - Definition

- * Passive surface measurement of the earth's natural electrical (**E**) & magnetic (**H**) fields
- * Measure changes in **E** and **H** with **time**
- * Frequency range **10k** to **0.0001** Hz
- * Used to derive the electrical resistivity (**conductivity**) structure of the subsurface.

Vertical component of the geomagnetic field (Hz): $H_z = a \cdot H_x + b \cdot H_y$
 Where *a* and *b* are complex functions of the frequency.
 Real part of *a* & *b* represent the **induction arrows** which used to define the **resistive** and **conductive** structure of the earth (**Geomagnetic deep sounding method**).

MT Data Record vs. Time

$$\rho_{xy} = \frac{1}{5f} \left| \frac{E_x}{H_y} \right|^2$$

Penetration Depth

$$\delta \approx 0.5 \sqrt{(\rho T)} \quad km$$

$$\delta \approx 0.5 \sqrt{(\rho / f)} \quad km$$

ρ a subsurface resistivity
 T a period of variations.

- ◆ For example, in sedimentary environment $\rho \sim 100$ ohm.m & frequency of 100 Hz the penetration depth is about 0.5 km

Site Requirements

- ◆ Magnetic sensors
- ◆ Electric field sensors
- ◆ Data acquisition systems

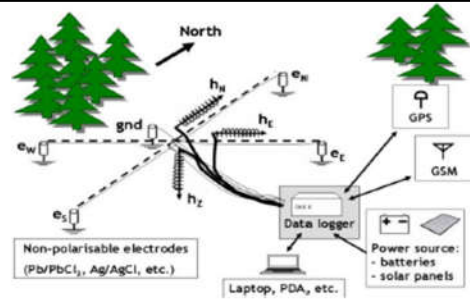

- 1 - instrument case
- 2 - Pb-PbCl₂ -electrodes
- 3 - three induction coils
- 4 - 3-component fluxgate magnetometer
- 5 - data logger (24 bit, 6 cha)
- 6 - 12V battery (50 – 120 Ah)
- 7 - GPS-antenna and cable
- 8 - GSM-antenna and modem
- 9 - rugged field laptop



Types of MT

- MT = magnetotellurics
 AMT = Audio MT
 LMT = Long MT
 CSAMT = Control Source AMT
 RMT = Radio MT

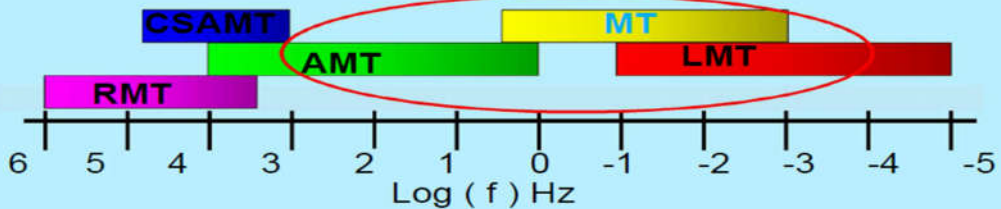

◆ MT

Generally refers to recording from
 0.001Hz to 1000 Hz

◆ AMT – Audio MT

Refers to “Audio” frequencies
 Generally recording > 100 Hz to 10k Hz

◆ LMT – Long period MT

Generally refers to recording from
 1,000 s to 10,000 s (0.001 Hz to 0.00001 Hz)

Broadband Magnetotelluric

Metronix –Germany
www.metronix.de

High frequencies
(>1 Hz) to 10k Hz

Low frequency
< 1 to 0.001 Hz

ADU – e7



6-Electromagnetic (EM) Methods

EM Applications:

- **Mineral exploration**, Mineral resource evaluation
- **Groundwater** surveys Mapping contaminant plumes
- **Geothermal resource** investigations Contaminated land mapping
- **Landfill surveys**
- Detection of geological and artificial **cavities**
- Location of geological **faults**, etc.
- Geological **mapping**

Electromagnetic Methods

1. **Source (TX):**
provides primary field



2. **EM induction:**
currents into conductors

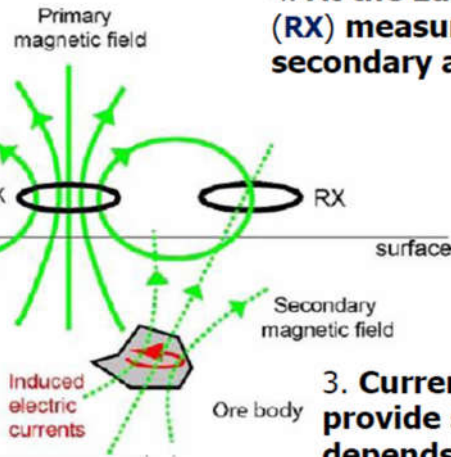

4. **At the Earth's surface, receiver (RX) measures the sum of the secondary and primary fields**

3. **Currents in conductors provide secondary field, which depends on the properties of the conductor**

A transmitter coil can be used to generate the primary electromagnetic field which propagates above and below the ground.

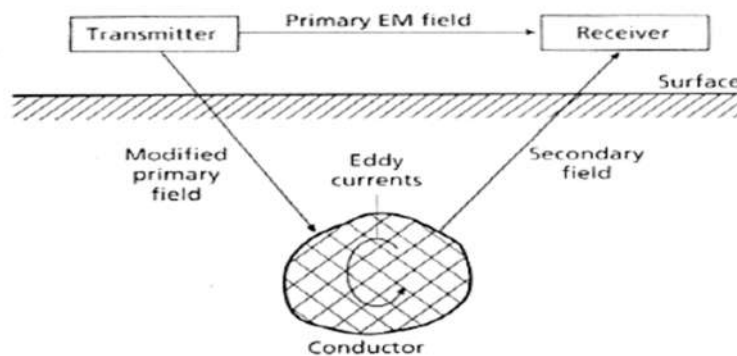

General principle of electromagnetic surveying

Primary and secondary fields

Where the subsurface is homogeneous there is **no** difference between the fields propagated above the surface and through the ground (only slight reduction in amplitude).

If a conductive anomaly is present, the magnetic component of the incident EM wave induces alternating currents (Eddy currents) within the conductor.

The eddy currents generate their own secondary EM-field which travels to the receiver.

The receiver also detects the primary field which travels through the air.

The receiver responds then to the resultant of the arriving primary and secondary fields.

Consequently, the measured response will differ in both phase and amplitude relative to the unmodulated primary field.

These differences between the transmitted and received EM fields reveal the presence of the conductor and provide information on its geometry and electrical properties.

- The **(EM)** have the broadest range of different instrumental systems. They can be classified as
 - * Time domain EM (**TEM**),
 - * Frequency domain (**FEM**) systems.

FEM: use one or more frequencies.

TEM: Measurements as a function of time.

- **EM** methods can be either **passive**, utilizing natural ground signals (**e.g. magnetotelluric**) or **active**, where an artificial transmitter is used either in the near field (as in **ground conductivity meters**) or in the far field (**using remote high powered military & civil radio transmitters as in the case of VLF and RMT methods**).

Advantage of EM-methods

- The main advantage of the (EM) is that they do not require direct contact with the ground as in the case of DC-electrical methods.

Therefore the EM-measurements can be carried out in a faster way than the DC-measurements.

- The range of EM applications is large.

It is dependent upon the type of equipment but

Penetration depth (D) is given by

$$d = 503 \sqrt{\rho/f} \quad (\text{m}).$$

Example: Depth of penetration

$\rho = 10 \quad \Omega \cdot \text{m}$

$f = 10 \text{ Hz}$

$D=503 \text{ m}$

$f = 100 \text{ Hz}$

$D=159 \text{ m}$

Comparison between EM and MT methods

Electromagnetic (EM) :

This is an active method that employs measurements of a time-varying magnetic field generated by induction through current flow within the earth.

In this technique, a time-varying magnetic field is generated at the surface of the earth that produces a time-varying electrical current in the earth through induction.

A receiver is deployed that compares the magnetic field produced by the current-flow in the earth to that generated at the source.

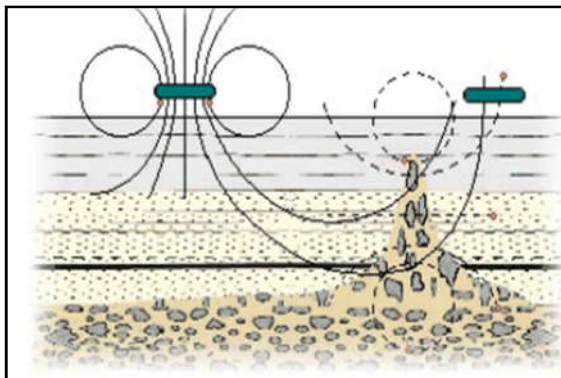

Magnetotelluric (MT) :

This is a passive method that employs measurements of naturally occurring electrical currents, telluric currents, generated by magnetic induction of electrical currents in the ionosphere. This method can be used to determine electrical properties of materials at relatively great depths (down to and including the mantle) inside the Earth. In this technique, a time variation in electrical potential is measured at a base station and at survey stations. Differences in the recorded signal are used to estimate subsurface distribution of electrical resistivity.

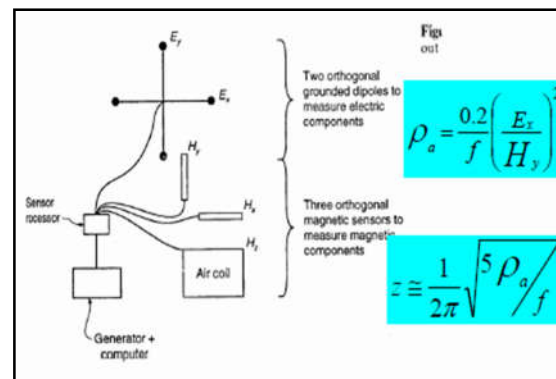

The range of applications for EM and MT surveying

Applications for EM

Exploration for:
 Hydrocarbons
 Massive sulphides
 Base and precious metals
 Geothermal resources

Geological mapping:
 Structure
 Lithology

Environmental applications:
 Mapping brine leakage from wells
 Mappings brine plumes from leaking tanks, etc.
 Mapping spilled petroleum products
 Monitoring leachate solution in *in situ* copper recovery projects

Geotechnical applications:
 Structural analysis in mine planning
 Void detection in underground mines
 Mapping burn fronts in underground coal mine fires
 Monitoring enhanced oil recovery

References to all published sources have been given by Zonge and Hughes (1991).

Applications for MT

Mineral exploration
Mineral resource evaluation
Hydrocarbon exploration
Monitoring hydrocarbon reservoirs
Groundwater surveys
Mapping contaminant plumes
Geothermal resource investigations
Contaminated land mapping
Landfill surveys
Detection of natural and artificial cavities
Location of geological faults
Geological mapping
Permafrost mapping
Brownfield site mapping
Unexploded Ordnance (UXO)
Sea-ice thickness mapping
Archaeological investigations
 *Independent of instrument type.

Seismic Methods

General

The basic principle of exploration seismology is for a signal to be generated at a time that is known exactly, and for the resulting seismic waves to travel through the subsurface media and be reflected and refracted back to the surface where the returning signals are detected. The elapsed time between the source being triggered and the arrival of the various waves is then used to determine the nature of the subsurface layers.

Derived information and applications of exploration seismology

Gross geological features:

- Depth to bedrock
- Measurement of glacier thickness
- Location of faults and fracture zones
- Fault displacement
- Location and character of buried valleys
- Lithological determinations
- Stratigraphy
- Location of basic igneous dykes

Petrophysical information:

- Elastic moduli
- Density
- Attenuation
- Porosity
- Elastic wave velocities
- Anisotropy
- Rippability

Applications:

- Engineering site investigations
- Rock competence
- Sand and gravel resources
- Detection of cavities
- Seabed integrity (for siting drilling rigs)
- Degassing or dewatering of submarine sediments
- Preconstruction site suitability for:
 - new landfill sites
 - major buildings
 - marinas and piers
 - sewage outfall pipes
 - tunnel construction, etc.
- Hydrogeology and groundwater exploration
- Ground particle velocities
- Forensic applications:
 - location of crashed aircraft on land
 - design of aircraft superstructures
 - monitoring Nuclear Test Ban Treaty
 - location of large bore military weapons
- Location of trapped miners
- Seismic hazard zonation

Elastic waves

When a stress is applied (or released) the corresponding strain propagates out from the source.

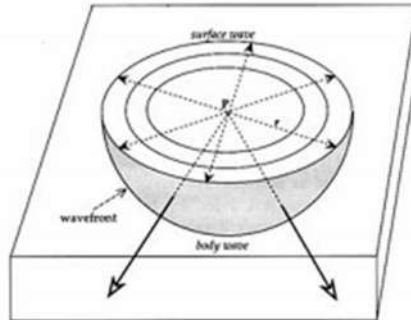

Fig. 3.9 Propagation of a seismic disturbance from a point source P near the surface of a homogeneous medium; the disturbance travels as a body wave through the medium and as a surface wave along the free surface.

Point source seismic disturbance:

- Wavefront expands out from the point: **Huygen's Principle**
- Body waves: sphere
- Surface waves: circle
- **Rays**: perpendicular to wavefront

Applied Geophysics – Waves and rays - I

Body waves P-waves

- P for "primary" or "push-pull"
- Compression and rarefaction, no rotation
- Causes volume change as the wave propagates
- Similar to sound waves traveling through air

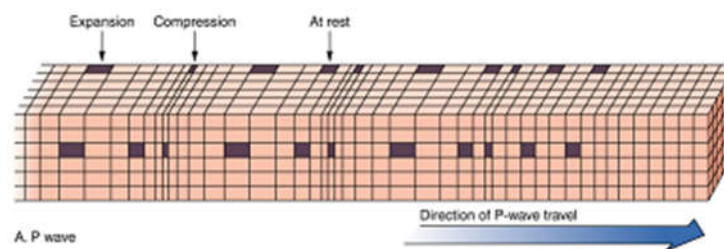

Applied Geophysics – Waves and rays - I

Body waves
S-waves

- S for "secondary" or "shear" and "shake"
- Shearing and rotation
- No volume change as the wave propagates

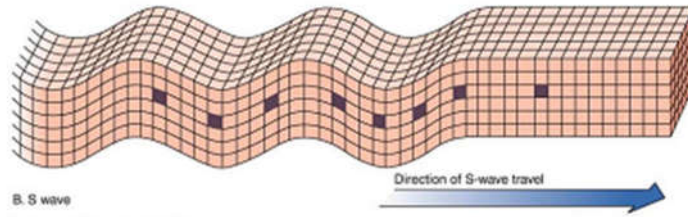

B. S wave
Copyright 1999 John Wiley and Sons, Inc. All rights reserved.

Applied Geophysics – Waves and rays - I

Body waves
P and S-waves

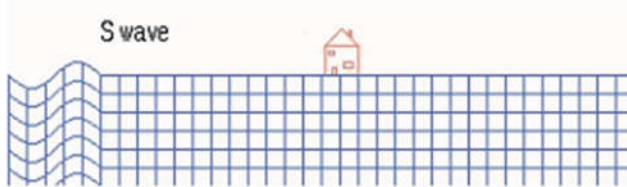
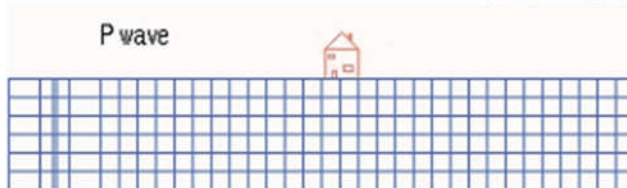
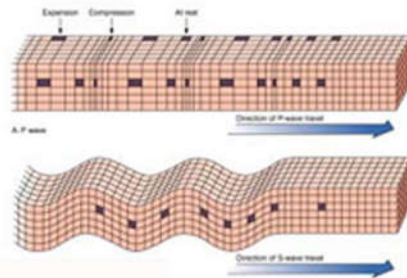

Applied Geophysics – Waves and rays - I

Surface waves

Rayleigh

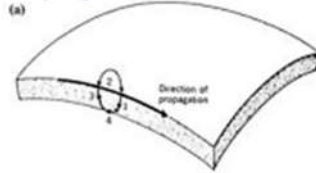

(a) Rayleigh wave

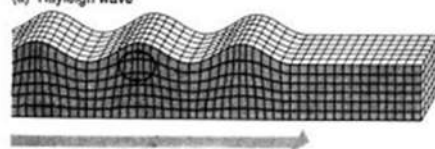

Love

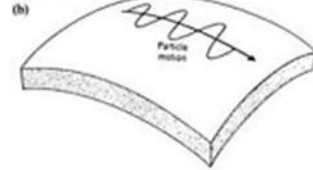

(b) Love wave



- Surface waves have lower velocities than body waves
- They are mainly a source of noise for us

Applied Geophysics – Waves and rays - I

Elastic moduli

describe the physical properties of the rock
...and determine the seismic velocity

Young's modulus

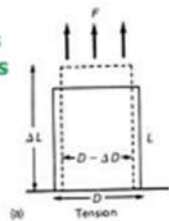

$$E = \frac{\text{longitudinal stress}}{\text{longitudinal strain}} = \frac{F/A}{\Delta L/L}$$

Poisson's ratio

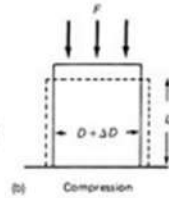

$$\nu = \frac{\text{transverse strain}}{\text{longitudinal strain}} = \frac{\Delta D/D}{\Delta L/L}$$

Shear modulus, μ

- Force per unit area to change the shape of the material

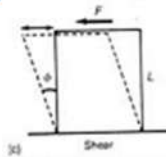

$$\mu = \frac{\text{shear stress}}{\text{shear strain}} = \frac{F/A}{\tan \phi}$$

Bulk modulus, κ

- Ratio of increase in pressure to associated volume change
- Always positive

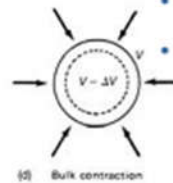

$$\kappa = \frac{\text{volume stress}}{\text{volume strain}} = \frac{P(\text{pressure})}{\Delta V/V}$$

Fig. 4.2 Common types of elastic stress and strain. Cross-sections of bodies shown before strain (solid line) and after strain (dashed line). Directions of stress are shown by thick arrows. The related elastic moduli are defined: (a,b) Young's modulus, E , and Poisson's ratio, ν ; (c) shear (or rigidity) modulus, μ ; (d) bulk modulus, κ . Application of uniform pressure shown by thick arrows around the body. Poisson's ratio is a measure of the relative deformation of the body in two perpendicular directions. F denotes the force acting on a cross-sectional area A .

Applied Geophysics – Waves and rays - I

Box 4.1 Elastic moduli

Young's modulus

$$E = \frac{\text{Longitudinal stress } \Delta F/A}{\text{Longitudinal strain } \Delta L/L} = \frac{\sigma}{\varepsilon}$$

(in the case of triaxial strain)

Bulk modulus

$$k = \frac{\text{Volume stress } \Delta P}{\text{Volume strain } \Delta v/v}$$

(in the case of excess hydrostatic pressure)

Shear (rigidity) modulus (a Lamé constant)

$$\mu = \frac{\text{shear stress } \tau}{\text{shear strain } \varepsilon}$$

($\mu \approx 7 \times 10^4 \text{MPa}$; $\mu = 0$ for fluids)

Axial modulus

$$U = \frac{\text{Longitudinal stress } \Delta F/A}{\text{Longitudinal strain } \Delta L/L} = \frac{\sigma}{\varepsilon}$$

(in the case with no lateral strain)

Relationships between Young's modulus (E), Poisson's ratio (σ), and the two Lamé constants (μ and λ)

$$E = \frac{\mu(3\lambda + 2\mu)}{(\lambda + \mu)} \quad \sigma = \frac{\lambda}{2(\lambda + \mu)} \quad k = \frac{3\lambda + 2\mu}{3}$$

and

$$\lambda = \frac{E\sigma}{(1 + \sigma)(1 - 2\sigma)}$$

Poisson's ratio ranges from 0.05 (very hard rocks) to 0.45 (for loose sediments). Elastic constants for rocks can be found in handbooks of physical constants.

Box 4.2 Seismic wave propagation velocity

Velocity of propagation V through an elastic material is:

$$V = (\text{Appropriate elastic modulus/density } \rho)^{1/2}$$

Velocity of P-waves is:

$$V_p = \left(\frac{k + 4\mu/3}{\rho} \right)^{1/2}$$

Velocity of S-waves is:

$$V_s = (\mu/\rho)^{1/2}.$$

The ratio V_p/V_s is defined in terms of Poisson's ratio (σ) and is given by:

$$\frac{V_p}{V_s} = \frac{(1 - \sigma)^{1/2}}{(1/2 - \sigma)} (*)$$

Note that $\mu = 0$ for a fluid, as fluids cannot support shear, and the maximum value of Poisson's ratio is 0.5; $\sigma \approx 0.05$ for very hard rocks, ≈ 0.45 for loose, unconsolidated sediments, average ≈ 0.25 .

Box 4.3 Elastic wave velocity as a function of geological age and depth (after Faust, 1951)

For shales and sands, the elastic wave velocity V is given by:

$$V = 1.47(ZT)^{1/6} \text{ km/s}$$

where Z is the depth (km) and T the geological age in millions of years.

Box 4.5 P-wave velocity as a function of temperature and salinity in water

$$V = 1449.2 + 4.6T - 0.055T^2 + 0.0003T^3 \\ + (1.34 - 0.01T)(S - 35) + 0.016d$$

where S and T are the salinity (parts per thousand) and the temperature ($^{\circ}\text{C}$); d is depth (m) (Ewing *et al.*, 1948; cf. Fofonoff and Millard, 1983).

Factors affecting velocity

$$V_P = \sqrt{\frac{\kappa + \frac{4}{3}\mu}{\rho}}$$
$$V_S = \sqrt{\frac{\mu}{\rho}}$$

Density – velocity typically increases with density

(κ and μ are dependant on ρ and increase more rapidly than ρ)

Porosity and fluid saturation

Increasing porosity reduces velocity.

Filling the porosity with fluid increases the velocity.

$$\frac{1}{V_{sat}} = \frac{\phi}{V_F} + \frac{1-\phi}{V_M}$$

Poisson's ratio – related to V_P/V_S

This is used to distinguish between rock/sediment types. It is usually more sensitive than just V_P alone.

The significant variations in sediments are usually due to porosity variations and water saturation. Water saturation has no effect on V_S (for low porosities) but a significant effect on V_P .

Applied Geophysics – Waves and rays - I

P and S-velocities

P-velocity

$$V_P = \sqrt{\frac{\kappa + \frac{4}{3}\mu}{\rho}}$$

change of shape and volume

S-velocity

$$V_S = \sqrt{\frac{\mu}{\rho}}$$

change of shape only

For liquids and gases $\mu = 0$, therefore

→ $V_S = 0$ and V_P is reduced in liquids and gases

→ Highly fractured or porous rocks have significantly reduced V_P

The bulk modulus, κ is always positive, therefore $V_S < V_P$ always

P-waves are the most important for controlled source seismology

- They arrive first making them easier to observe
- It is difficult to create a shear source, explosions are compressional

Applied Geophysics – Waves and rays - I

Seismic Velocities of Earth Materials

The P and S wave velocities of various earth materials are shown below.

Material	P wave Velocity (m/s)	S wave Velocity (m/s)
Air	332	
Water	1400-1500	
Petroleum	1300-1400	
Steel	6100	3500
Concrete	3600	2000
Granite	5500-5900	2800-3000
Basalt	6400	3200
Sandstone	1400-4300	700-2800
Limestone	5900-6100	2800-3000
Sand (Unsaturated)	200-1000	80-400
Sand (Saturated)	800-2200	320-880
Clay	1000-2500	400-1000
Glacial Till (Saturated)	1500-2500	600-1000

Generation of Seismic Waves (Sources)

		On land	On water
<i>Impact:</i>	Sledge hammer Drop-weight Accelerated weight		
<i>Impulsive:</i>	Dynamite	Airgun	Pinger Boomer Sparker
	Detonating cord Airgun Shotgun Borehole sparker	Gas gun Sleeve gun Water gun Steam gun	
<i>Vibrator:</i>	Vibroseis Vibrator plate Rayleigh wave generator	Multipulse GeoChirp	

Recording of Seismic Waves

Geophones Hydrophones

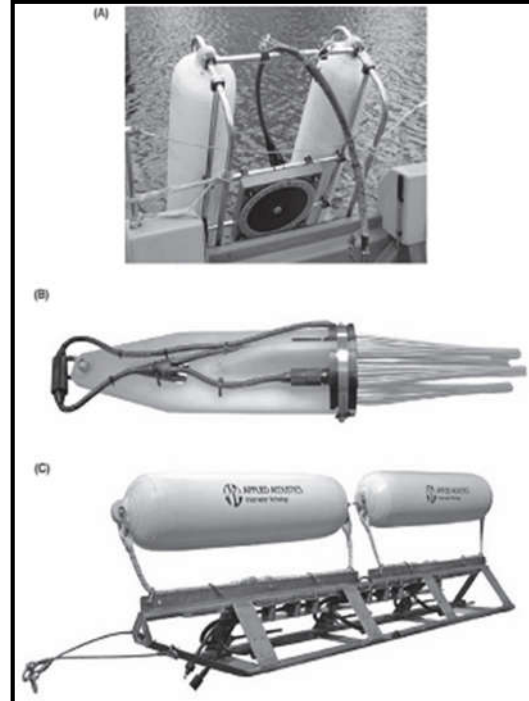
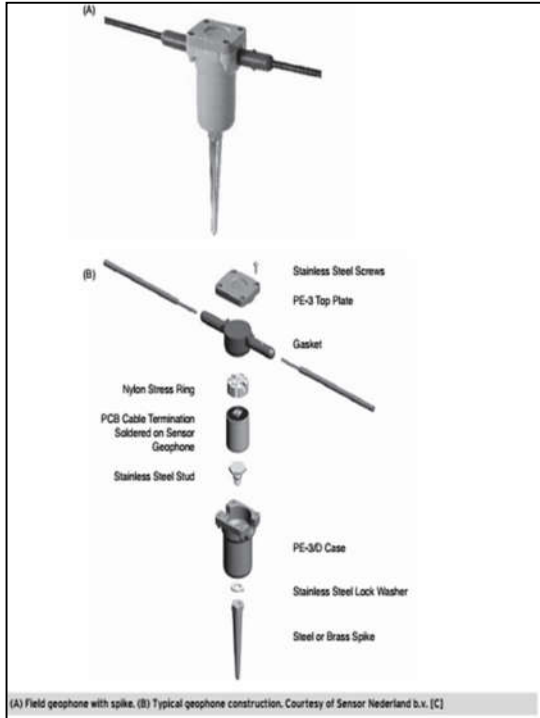

Reflection and transmission

V_{p1}
 V_{s1}
 ρ_1

V_{p2}
 V_{s2}
 ρ_2

— longitudinal
— transverse

Light ray

Refraction bends ray toward base of prism

Prism

Seismic rays obey Snell's Law
(just like in optics)

The angle of incidence equals the angle of reflection, and the angle of transmission is related to the angle of incidence through the velocity ratio.

But a conversion from P to S or vice versa can also occur. Still, the angles are determined by the velocity ratios.

$$\frac{\sin i_p}{V_{p1}} = \frac{\sin R_p}{V_{p1}} = \frac{\sin r_p}{V_{p2}} = \frac{\sin R_s}{V_{s1}} = \frac{\sin r_s}{V_{s2}} = p$$

where p is the **ray parameter** and is constant along each ray.

Applied Geophysics – Waves and rays - I

Critical incidence

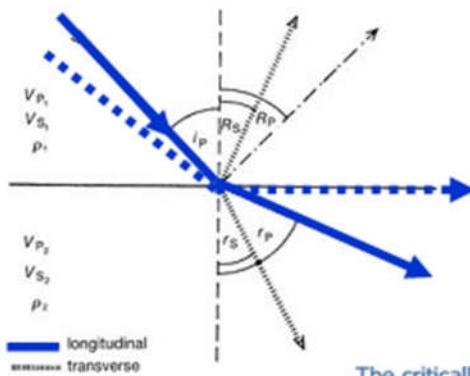

$$\frac{\sin i_p}{V_{p1}} = \frac{\sin r_p}{V_{p2}}$$

when $V_2 > V_1$, $r_p > i_p$

therefore, we can increase i_p until $r_p = 90^\circ$

When $r_p = 90^\circ$ $i_p = i_c$ the critical angle

$$\sin i_c = \frac{V_{p1}}{V_{p2}}$$

The critically refracted energy travels along the velocity interface at V_2 continually refracting energy back into the upper medium at an angle i_c

→ a head wave

Applied Geophysics – Waves and rays - I

Head wave

- Occurs due to a low to high velocity interface
- Energy travels along the boundary at the higher velocity
- Energy is continually refracted back into the upper medium at an angle i_c
- Provides constraints on the boundary depth e.g. Moho depth

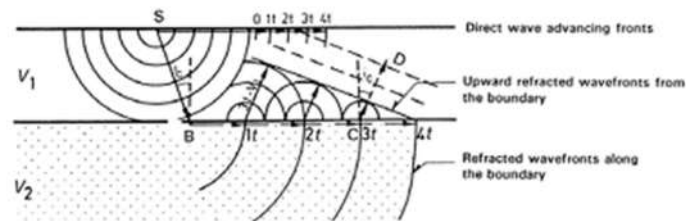
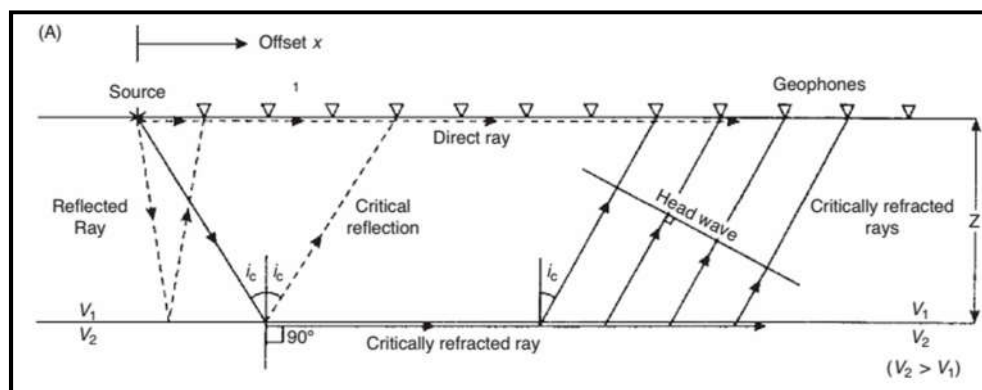

Fig. 4.6 Schematic illustration showing the ray paths of the incident wave (SB) striking the boundary at critical angle (i_c), and the refracted wave (BC) traveling along the boundary with velocity $V_2 (>V_1)$. The latter is refracted back to the first medium (V_1) at the same angle (i_c) and re-emerges with a ray path such as CD. Advancement of the wavefronts is shown from the instant ($t=0$) when the incident ray strikes the boundary at B. (Modified from Klitten, 1987.)

Applied Geophysics – Waves and rays - I

Seismic Refraction Method

Seismic refraction experiments can be undertaken at three distinct scales: global (using earthquake waves), crustal (using explosion seismology), and near-surface (engineering applications). The more conventional engineering applications of foundation studies for dams and major buildings, seismic refraction is increasingly being used in hydrogeological investigations to determine saturated aquifer thickness, weathered fault zones, and so on. The location of faults, joints, and other such disturbed zones using seismic refraction is of major importance in the consideration of the suitability of potential sites for the safe disposal of particularly toxic hazardous waste.



Experiment design

Geophones: often use the same geophones as in reflection work – constraint is the frequency of the geophones

Frequency: refraction studies may be constrained to lower frequencies due to longer ray lengths (10Hz vs. 100Hz for reflection)

Profile length: typically 5 to 10 times the depth of the refractor to ensure head wave as first arrival

Shot points: Typically five for each geophone array

- One at each end: uppermost velocity plus reversed line
- One at center: to determine uppermost layer velocity
- Two long offset shots: to determine phantom arrivals and reverse line

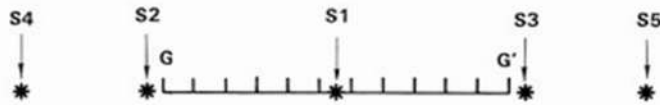

Applied Geophysics – Refraction II

Horizontal interface

Traveltime equations

Direct wave:

$$T = \frac{x}{V_1}$$

Head wave:

$$T = T_{SB} + T_{DB'} + T_{BD}$$

$$T = \frac{2h_1}{V_1 \cos i_c} + \frac{x - 2h_1 \tan i_c}{V_2}$$

$$T = \frac{x}{V_2} + \frac{2h_1 \sqrt{V_2^2 - V_1^2}}{V_2 V_1}$$

$$T = ax + b$$

slope: $1/V_2$
intercept: gives h_1

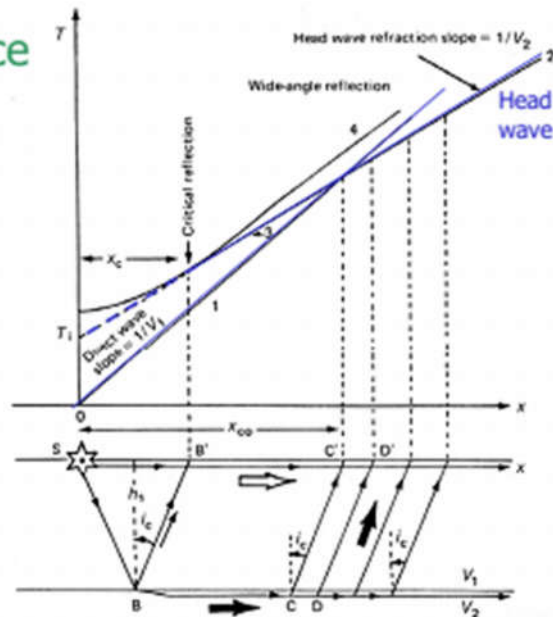

Fig. 4.34 Principle of the seismic refraction method. Travel-time curves for direct waves, critically refracted waves (head waves), late refracted arrivals, and reflected waves are shown by numbers 1-4, respectively. Note that critically refracted waves start arriving after a critical distance x_c , but they overtake the direct waves at a crossover distance x_{co} .

Applied Geophysics – Refraction I

Horizontal interface

Crossover distance, x_{co}

Where the direct and head wave cross. Their travel times are equal:

$$\frac{x_{co}}{V_1} = \frac{x_{co}}{V_2} + \frac{2h_1\sqrt{V_2^2 - V_1^2}}{V_2V_1}$$

$$x_{co} = 2h_1 \frac{\sqrt{V_2 + V_1}}{\sqrt{V_2 - V_1}}$$

Another approach to obtaining layer thickness

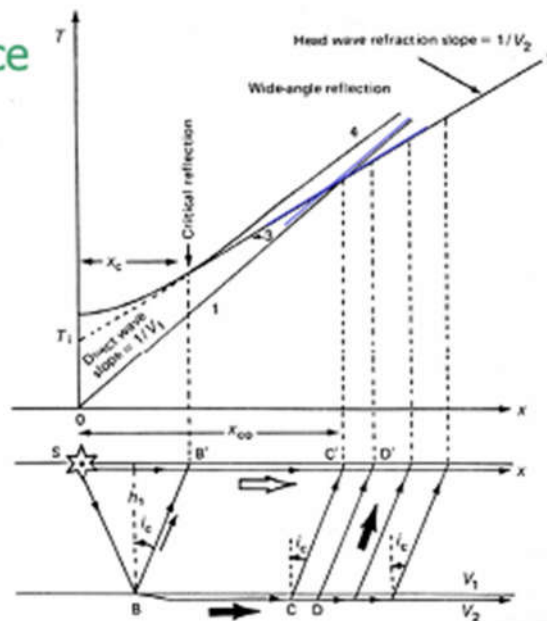
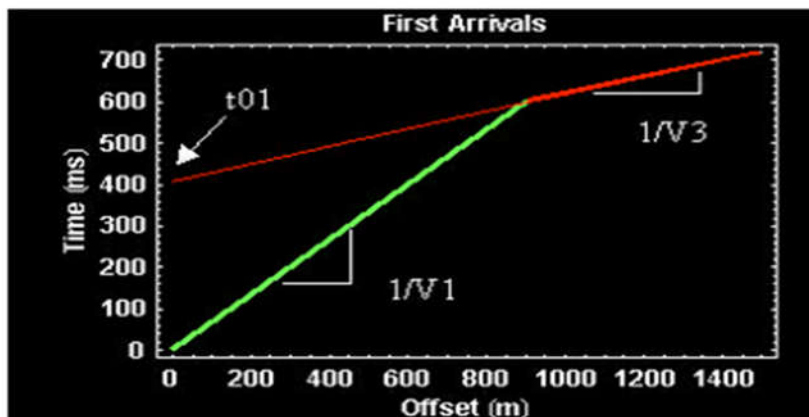
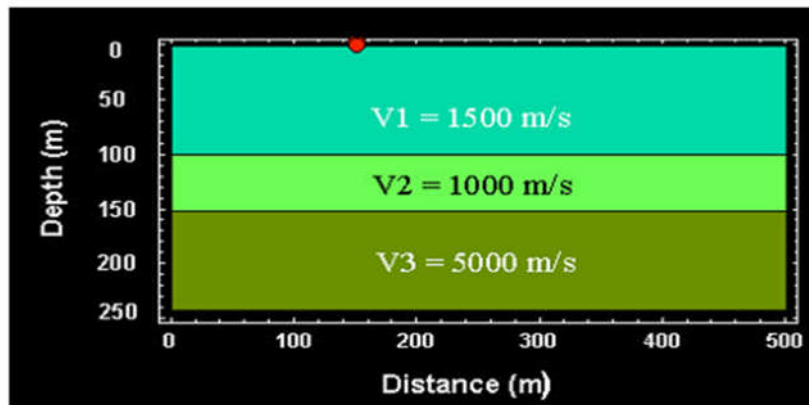

Fig. 4.34 Principle of the seismic refraction method. Travel-time curves for direct waves, critically refracted waves (head waves), late refracted arrivals, and reflected waves are shown by numbers 1-4, respectively. Note that critically refracted waves start arriving after a critical distance x_c , but they overtake the direct waves at a crossover distance x_{co} .

Applied Geophysics – Refraction I

Limitations of Seismic Refraction



Limitations
Low velocity layers

- They are completely invisible to the refraction method
- They will cause miss-interpretation of the depth of lower lying layers

The intercept of the refraction from layer 3 will be dependent on the thickness and velocity in layer 2

- Lower layers appear deeper than they are

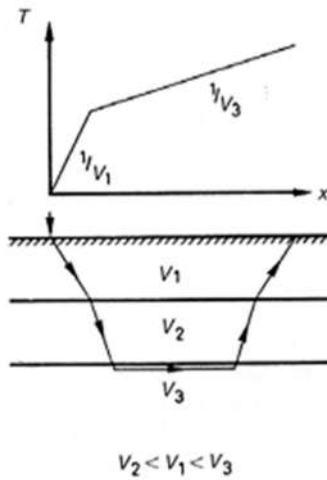

Applied Geophysics – Refraction II

There are four causes of this limitation of seismic refraction

1- velocity inversion;

2- lack of velocity contrast;

3- the presence of a thin bed; and

4- inappropriate spacing of geophones

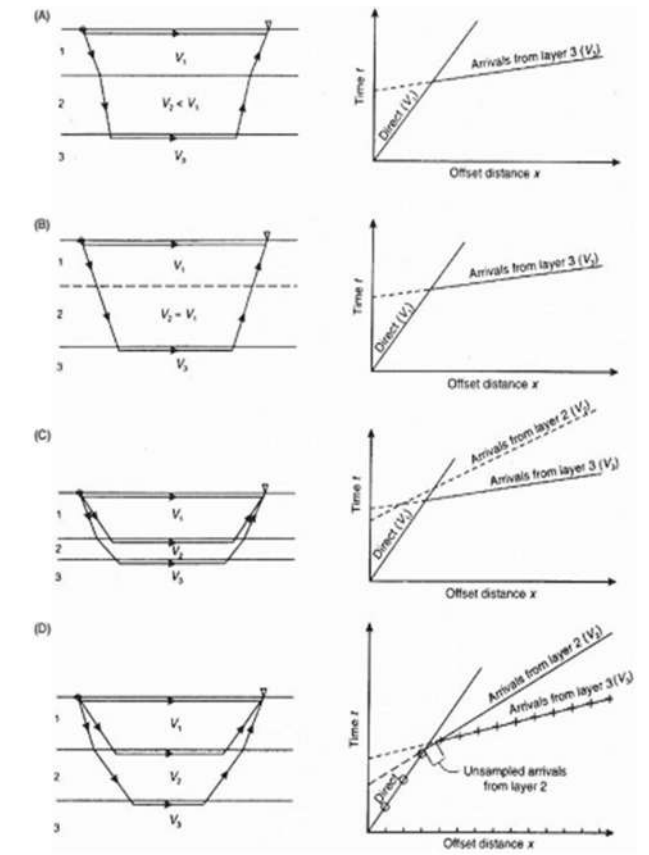

2- Seismic reflection Method

The essence of the seismic reflection technique is to measure the time taken for a seismic wave to travel from a source (at a known location at or near the surface) down into the ground where it is reflected back to the surface and then detected at a receiver, which is also at or near the surface at a known position. This time is known as the **two-way travel time (TWTT)**.

Reflection surveying

- Sensitive to impedance contrasts
- Use near-normal incidence i.e. P-waves

Target scale:

- 10's m: Ground water, engineering and environmental studies
- km's: Oil exploration
- 10's km: Crustal structure

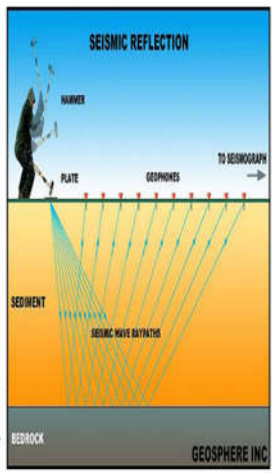

The diagram illustrates a seismic reflection survey. A source (marked with a hammer) is located on a plate. Geophones are placed on the surface to detect reflected waves. The subsurface consists of a sediment layer (with properties $\rho_1 v_1$) and a bedrock layer (with properties $\rho_2 v_2$). Seismic wave rays are shown reflecting off the sediment-bedrock interface. The text 'GOSPHERE INC' is visible at the bottom right of the diagram.

Applied Geophysics – Seismic reflection I

Seismic Reflection

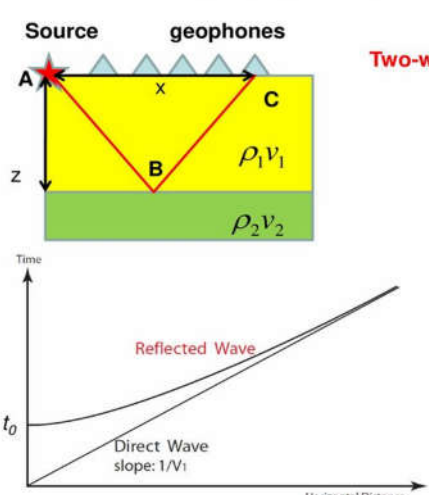

The diagram shows a source at point A and geophones at points B and C. The horizontal distance from the source to the geophone is x . The depth of the reflector is z . The upper layer has properties $\rho_1 v_1$ and the lower layer has properties $\rho_2 v_2$. The reflected wave path is shown as a red line from A to B to C. The direct wave path is shown as a black line from A to C.

Two-way travel time is:
$$t = \frac{AB}{v_1} + \frac{BC}{v_1}$$

$$t = \frac{2}{v_1} \sqrt{z^2 + \frac{x^2}{4}}$$

Or

$$t^2 = 4 \frac{z^2}{v_1^2} + \frac{x^2}{v_1^2} = t_0^2 + \frac{x^2}{v_1^2}$$

- t_0 is the two-way normal incidence travel time
- An horizontal reflector generates an **hyperbola** in time
- The V velocity can be determined by plotting t^2 as function of x^2 .

The graph below shows Time on the vertical axis and Horizontal Distance on the horizontal axis. A straight line represents the Direct Wave with a slope of $1/v_1$. A hyperbolic curve represents the Reflected Wave, starting at t_0 on the vertical axis.

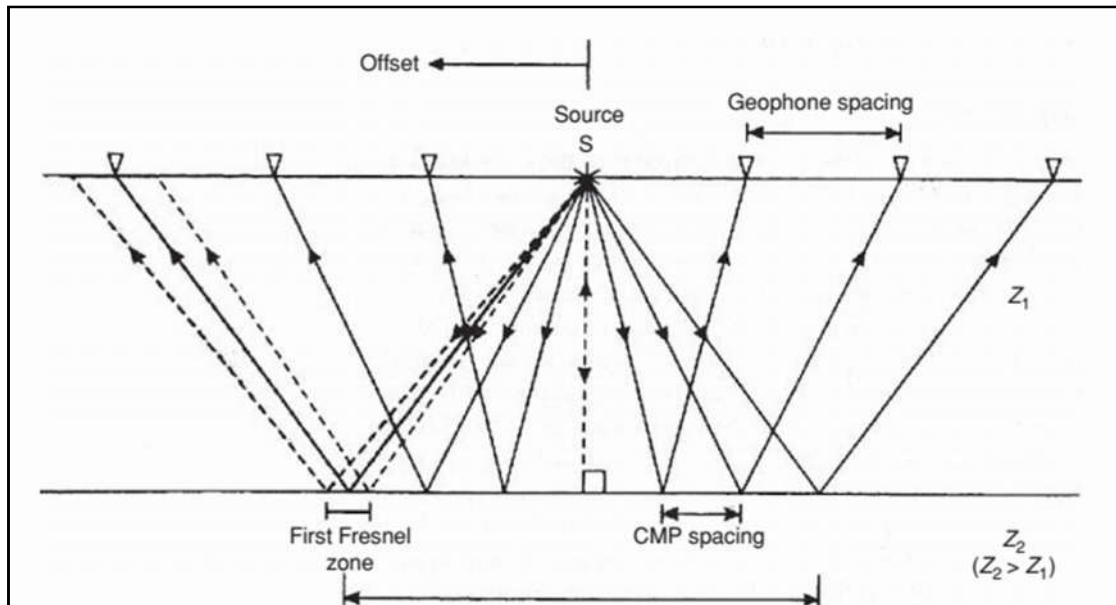

Applications of seismic reflection

- ❖ hydrocarbon exploration
- ❖ research into crustal structure, with depths of penetration of many kilometers now being
- ❖ engineering and environmental investigations where depths of penetration are typically less than 200 m.

Applications of shallow high-resolution seismic reflection -surveying include mapping Quaternary deposits, buried rock valleys and shallow faults; hydrogeological studies of aquifers; shallow coal exploration; and pre-construction ground investigations for pipe, cable and sewerage tunnel schemes, and offshore wind farms.

Common midpoint gathers

To enhance signal to noise we use more than one shot

Reflections from the same point are recorded by different source-station pairs

→ Common depth point gather

For dipping layers the reflection points are "smeared"

→ Common midpoint gather

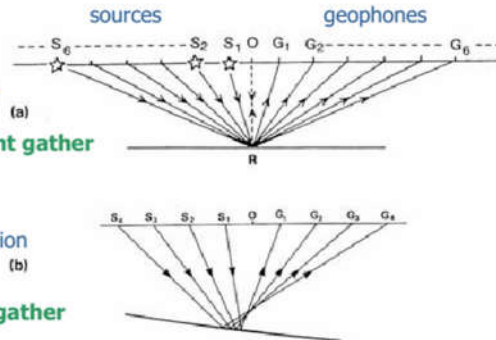

Fig. 4.16 (a) Ray paths of reflections belonging to the common-depth point (CDP) which is located below the shot-geophone common midpoint, O. The arrangement shown gives a six-fold coverage of the subsurface reflection point, R, on a horizontal reflector. (b) For a dipping reflector, the reflection point is not vertically below the shot-geophone midpoint, O.

Applied Geophysics – Seismic reflection I

If more than one shot location is used, reflections arising from the same point on the interface will be detected at different geophones. This common point of reflection is known as the **common midpoint (CMP)**. Sometimes the terms **common depth point (CDP)** and **common reflection point (CRP)** are used as being equivalent to CMP. This is true, however, only in the case of flat horizons with no lateral velocity variation. If the reflector is dipping, the points of reflection are smeared along the interface (Figure 6.2B). According to Snell's Law, the angle of reflection equals the angle of incidence, and it is for this reason that the point of reflection moves upslope with greater shot-geophone offset. It is recommended that only the term '**common midpoint**' be used.

Vertical seismic profiling (VSP).

Vertical seismic profiling (VSP) is effectively seismic surveying using boreholes. Seismic detectors are located at known levels within a borehole and shots fired at the surface, and vice versa.

The VSP method utilizes both the downgoing wave field as well as the reflected and/or diffracted wave field to provide additional information about the zone imaged

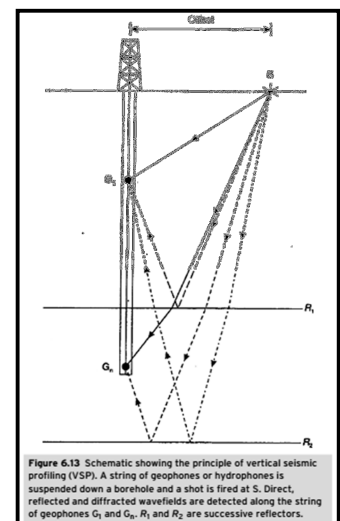
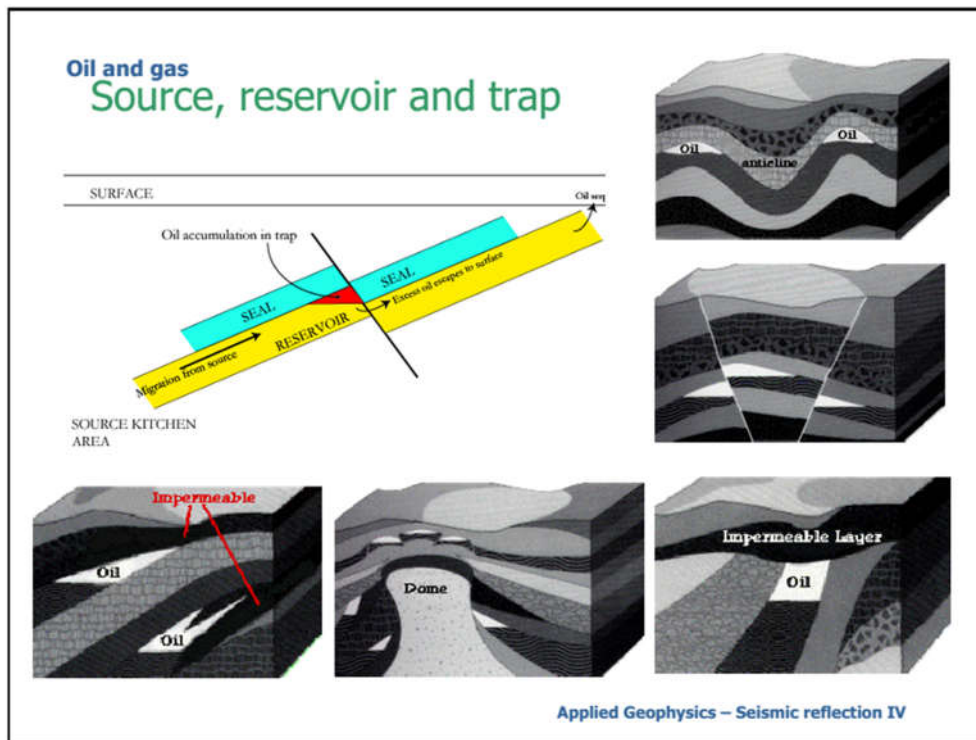
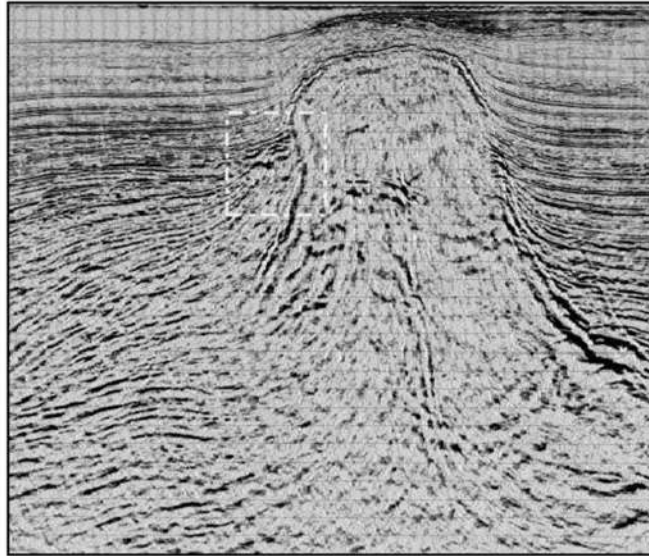
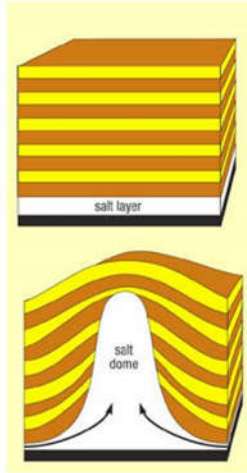

Figure 6.13 Schematic showing the principle of vertical seismic profiling (VSP). A string of geophones or hydrophones is suspended down a borehole and a shot is fired at S. Direct, reflected and diffracted wavefields are detected along the string of geophones G_1 and G_2 . R_1 and R_2 are successive reflectors.

by the method. There are several different types of VSP configurations such as static VSP, with one string of detectors at a fixed position with a single shot at the surface single-level walkaway VSP, where shots are fired into one down hole detector from source points with increasing distance from the wellhead (i.e. walking away from the hole); and multilevel walkaway VSP – the same as for single-level walkaway VSP but with a string of down hole detectors over a wide range of depth levels.



Examples
Salt dome
 Common traps in Gulf of Mexico



Applied Geophysics – Seismic reflection IV

Examples
Faults and flat spots

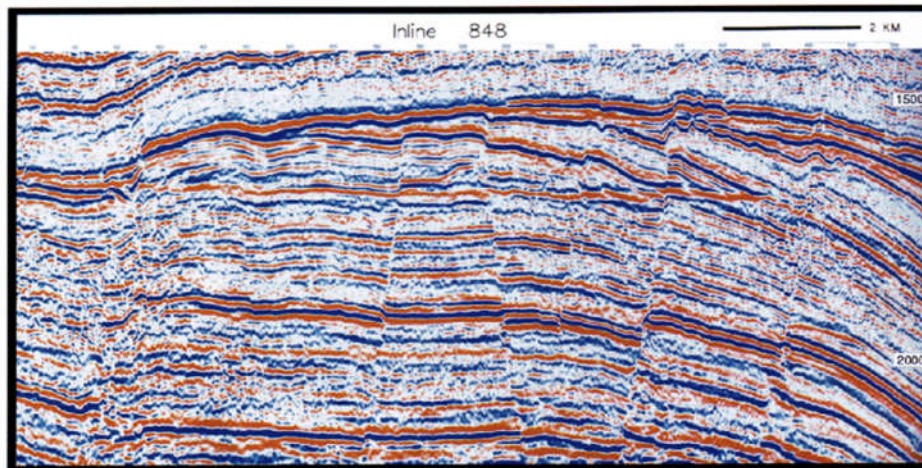

Fig. 5-17. Vertical section across Troll gas field offshore Norway. Note 7 km long flat spot at about 1700 ms. The reservoir is Jurassic in age with an average porosity of 28%. (Courtesy Norsk Hydro a.s.)

Flat spots and bright spots:
 indicate oil or gas

Applied Geophysics – Seismic reflection IV

Examples Locating faults

- Migrating fluids
- Seismic hazard

Identified as discontinuities
in reflection surfaces

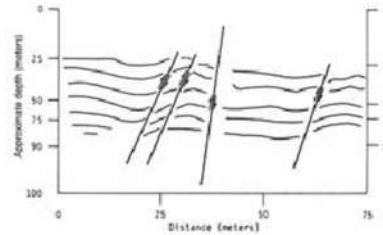

None of these
faults visible at
the surface –
suggests recent
inactivity

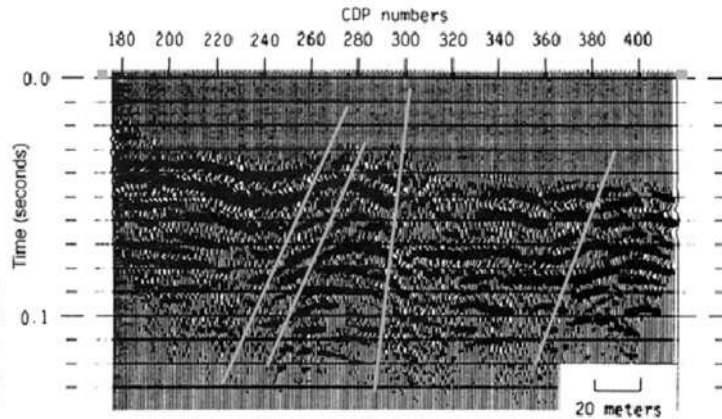

Applied Geophysics – Seismic reflection IV

Examples Groundwater

Objective:
Map subsurface
location of aquifer
for the purpose of
drilling a well

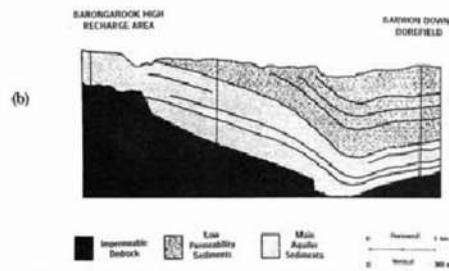
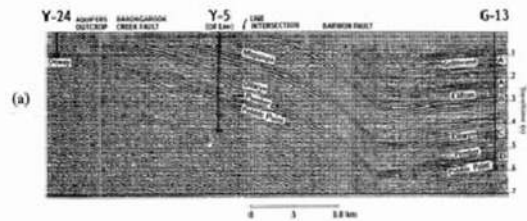

Fig. 4.29 (a) Seismic section below the survey line Y-24-G-13 (see location map, Fig. 4.28). Amplitude normalization and 3x vertical exaggeration used to emphasize structure in this section across the Barwon Downs graben. Main aquifer units are named below the line intersection; borhohles shown by thick solid lines. (b) Yodene survey hydrogeological interpretation. The basal Tertiary aquifer system, confined between a calcareous aquitard cap and impermeable bedrock, is shown to be continuous between the Barongarook recharge area and the Barwon Downs extraction area. (After Geissler, 1989.)

Applied Geophysics – Seismic reflection IV