

2022-2023

PHYSICAL OPTICS

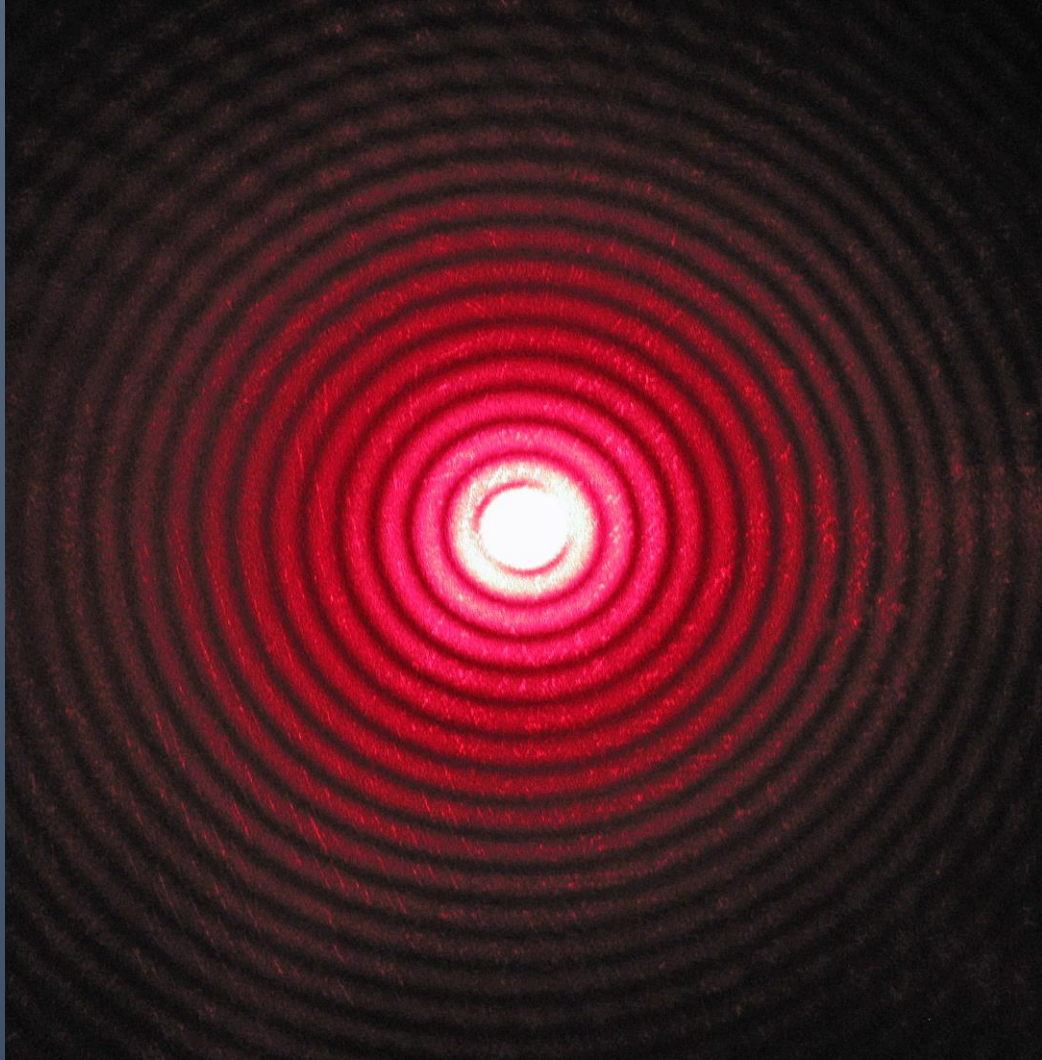

SOUTH VALLEY UNIVERSITY

The Nature of Light

Before the beginning of the nineteenth century, light was considered to be a stream of particles that either was emitted by the object being viewed or emanated from the eyes of the viewer. Newton, the chief architect of the particle theory of light, held that particles were emitted from a light source and that these particles stimulated the sense of sight upon entering the eye. Using this idea, he was able to explain reflection and refraction.



Sir Isaac Newton
(1642-1727)

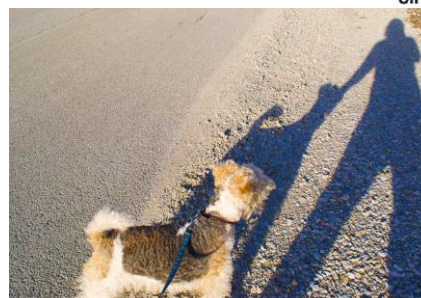
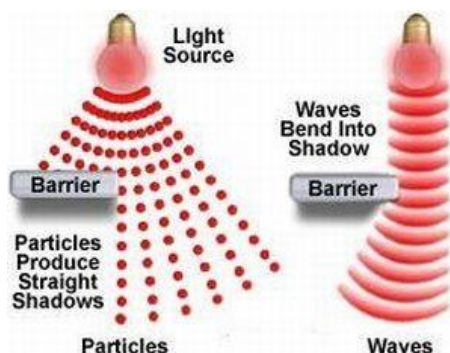

Most scientists accepted

Newton's particle theory. During his lifetime, however, another theory was proposed—one that argued that light might be some sort of wave motion. In 1678, the Dutch physicist and astronomer Christian Huygens showed that a wave theory of light could also explain reflection and refraction.



Christiaan Huygens
(1629-1695)

In 1801, Thomas Young (1773–1829) provided the first clear demonstration of the wave nature of light. Young showed that, under appropriate conditions, light rays interfere with each other. Such behaviour could not be explained at that time by a particle theory because there was no conceivable way in which two or more particles could come together and cancel one another.



Thomas Young
(1773-1829)

Additional developments during the nineteenth century led to the general acceptance of the wave theory of light, the most important resulting from the work of Maxwell, who in 1873 asserted that light was a form of high-frequency electromagnetic wave. As discussed, Hertz provided experimental confirmation of Maxwell's theory in 1887 by producing and detecting electromagnetic waves.

Although the wave model and the classical theory of electricity and magnetism were able to explain most

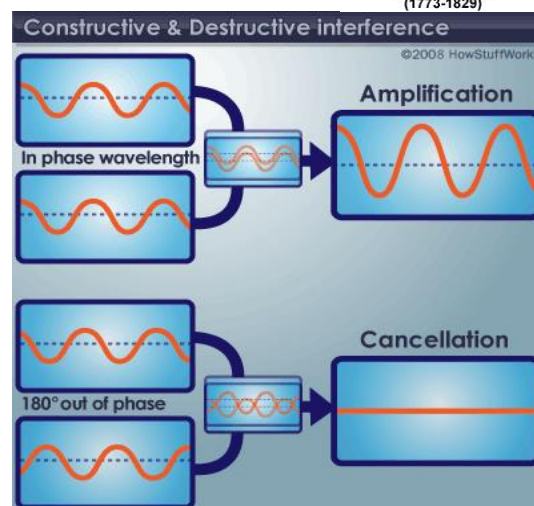

known properties of light, they could not explain some subsequent experiments. The most striking of these is the photoelectric effect, also discovered by Hertz: when light strikes a metal surface, electrons are sometimes ejected from the surface. As one example of the difficulties that arose, experiments showed that the kinetic energy of an ejected electron is independent of the light intensity. This finding contradicted the wave theory, which held that a more intense beam of light should add more energy to the electron.

An explanation of the photoelectric effect was proposed by Einstein in 1905 in a theory that used the concept of quantization developed by Max Planck (1858–1947) in 1900. The quantization model assumes that the energy of a light wave is present in particles called photons; hence, the energy is said to be quantized. According to Einstein's theory, the energy of a photon is proportional to the frequency of the electromagnetic wave:

$$E=hf$$

where the constant of proportionality $h = 6.63 \times 10^{-34}$ J.s is Planck's constant.

In view of these developments, light must be regarded as having a dual nature: **Light exhibits the characteristics of a wave in some situations and the characteristics of a particle in other situations.**

Light is light, to be sure. However, the question —Is light a wave or a particle? is inappropriate. Sometimes light acts like a wave, and at other times it acts like a particle.

The properties of light can be summarized into two groups...with its dual nature

3 "particle" properties

- ✓ **Travels in straight lines**
- ✓ **Reflection** (changes direction).
- ✓ **Refraction** (bends, in going from one material to another).

3 "wave" properties

- ✓ **Interference** (waves "superpose" and pass right through each other).
- ✓ **Diffraction** (waves "spill over" the edges of their obstructions).
- ✓ **Polarization** (eliminating one of light's "fields").



Albert Einstein
(1879-1955)



Max Planck
(1858-1947)

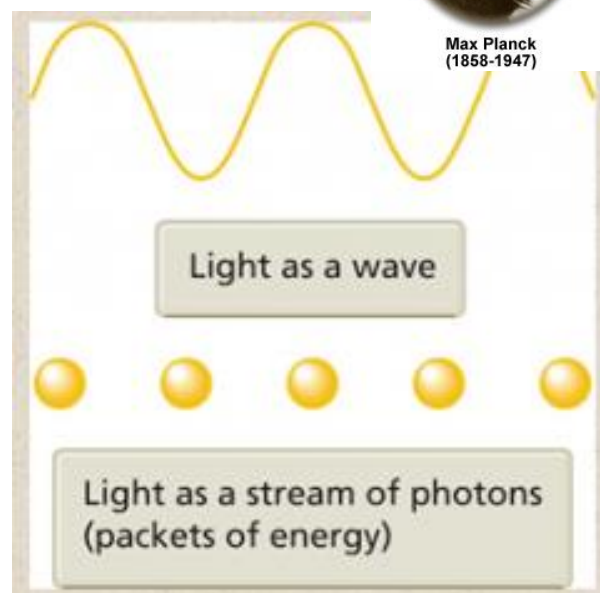

Periodic Motion

motion of the hands of a clock, motion of the wheels of a car and motion of a planet around the sun? They all are repetitive in nature, that is, they repeat their motion after equal intervals of time. A motion which repeats itself in equal intervals of time is periodic.

A body starts from its equilibrium position (at rest) and completes a set of movements after which it will return to its equilibrium position. This set of movements repeats itself in equal intervals of time to perform the periodic motion.

Circular motion is an example of periodic motion. Very often the equilibrium position of the body is in the path itself. When the body is at this position, no external force is acting on it. Therefore, if it is left at rest, it remains at rest.

We know that motion which repeats itself after equal intervals of time is periodic motion. The time interval after which the motion repeats itself is called time period (T) of periodic motion. Its S. I. unit is second.

The reciprocal of T gives the number of repetitions per unit time. This quantity is the frequency of periodic motion. The symbol ν represents frequency. Therefore, the relation between ν and T is

$$\nu = 1/T$$

Thus, the unit of ν is s^{-1} or hertz (after the scientist Heinrich Rudolf Hertz). Its abbreviation is Hz. Thus, 1 hertz = 1 Hz = 1 oscillation per second = 1 s^{-1} The frequency of periodic motion may not be an integer. It can be a fraction.

Oscillatory Motion

Everybody at rest is in its equilibrium position. At this position, no external force is acting on it. Therefore, the net force acting on the body is zero. Now, if this body is displaced a little from its equilibrium position, a force acts on the body which tries to bring back the body to its equilibrium position. This force is the restoring force and it gives rise to oscillations or vibrations.

For example, consider a ball that is placed in a bowl. It will be in its equilibrium position. If displaced a little from this position, it will perform oscillations in the bowl. Therefore, every oscillatory motion is periodic, but all periodic motions are not oscillatory. Circular motion is a periodic motion but not oscillatory motion.

There is no significant difference between oscillations and vibrations. When the frequency is low, we call it oscillatory motion and when the frequency is high, we call it vibrations. Simple harmonic motion is the simplest form of oscillatory motion. This motion takes place when the restoring force acting on the body is directly proportional to its displacement from its equilibrium position.

In practice, Oscillatory motion eventually comes to rest due to damping or frictional forces. However, we can force them by means of some external forces. A number of oscillatory motions together form waves like electromagnetic waves.

Displacement in Oscillatory Motion

Displacement of a particle is a change in its position vector. In an oscillatory motion, it simply displacement means a change in any physical property with time.

Consider a block attach to a spring, which in turn is fixed to a rigid wall. We measure the displacement of the block from its equilibrium position. In an oscillatory motion, we can represent the displacement by a mathematical function of time. One of the simplest periodic functions is given by,

$$f(t) = A \cos \omega t$$

If the argument, ωt , is increased by an integral multiple of 2π radians, the value of the function remains the same. Therefore, it is periodic in nature and its period T is given by,

$$T = 2\pi/\omega$$

Thus, the function $f(t)$ is periodic with period T .

$$\therefore f(t) = f(t + T).$$

Now, if we consider a sine function, the result will be the same. Further, taking a linear combination of sine and cosine functions is also a periodic function with period T .

$$f(t) = A \sin \omega t + B \cos \omega t$$

Taking

$A = D \cos \phi$ and $B = D \sin \phi$ equation V becomes,

$$f(t) = D \sin(\omega t + \phi)$$

In this equation D and ϕ are constant and they are given by,

$$D = \sqrt{A^2 + B^2} \text{ and } \phi = \tan^{-1}(B/A)$$

Therefore, we can express any periodic function as a superposition of sine and cosine functions of different time periods with suitable coefficients. The period of the function is $2\pi/\omega$.

Difference Between Periodic and Oscillatory Motion

The main difference is that oscillatory motion is always periodic, but a periodic motion may or may not be oscillatory motion. For example, the motion of a pendulum is both oscillatory motion and periodic motion but the motion of the wheels of a car is only periodic because the wheels rotate in a circular motion. Circular motion is only periodic motion and not oscillatory motion. The wheels do not move to and fro about a mean position.

Quiz

In periodic motion, the displacement is.

- a) directly proportional to the restoring force.
- b) inversely proportional to the restoring force.
- c) independent of restoring force.
- d) none of them.

Solution:

a) directly proportional to the restoring force. The displacement of the body from its equilibrium is directly proportional to the restoring force. Therefore, higher the displacement, higher is the restoring force.

Simple Harmonic Motion

We see different kinds of motion every day. The motion of the hands of a clock, motion of the wheels of a car, etc. Did you ever notice that these types of motion keep repeating themselves? Such motions are periodic in nature. One such type of periodic motion is simple harmonic motion (S.H.M.). But what is S.H.M.? Let's find out.

Simple Harmonic Motion (S.H.M.)

When an object moves to and fro along a line, the motion is called simple harmonic motion. Have you seen a pendulum? When we swing it, it moves to and fro along the same line. These are called oscillations. Oscillations of a pendulum are an example of simple harmonic motion.

Now, consider there is a spring that is fixed at one end. When there is no force applied to it, it is at its equilibrium position. Now,

- If we pull it outwards, there is a force exerted by the string that is directed towards the equilibrium position.
- If we push the spring inwards, there is a force exerted by the string towards the equilibrium position.

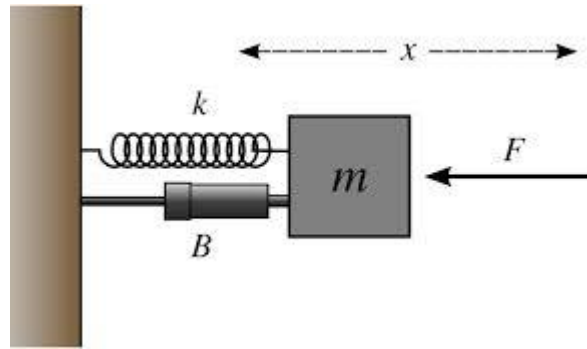

In each case, we can see that the force exerted by the spring is towards the equilibrium position. This force is called the restoring force. Let the force be F and the displacement of the string from the equilibrium position be x .

Therefore, the restoring force is given by, $F = -kx$ (the negative sign indicates that the force is in opposite direction). Here, k is the constant called the force constant. Its unit is N/m in S.I. system and dynes/cm in C.G.S. system.

Linear Simple Harmonic Motion

Linear simple harmonic motion is defined as the linear periodic motion of a body in which the restoring force is always directed towards the equilibrium position or mean position and its magnitude is directly proportional to the displacement from the equilibrium position. All simple harmonic motions are periodic in nature, but all periodic motions are not simple harmonic motions.

Now, take the previous example of the string. Let its mass be m . The acceleration of the body is given by,

$$a = F/m = -kx/m = -\omega^2 x$$

Here, $k/m = \omega^2$ (ω is the angular frequency of the body)

Concepts of Simple Harmonic Motion (S.H.M)

- **Amplitude:** The maximum displacement of a particle from its equilibrium position or mean position is its amplitude. Its S.I. unit is the metre. The dimensions are $[\text{L}^1 \text{M}^0 \text{T}^0]$. Its direction is always away from the mean or equilibrium position.
- **Period:** The time taken by a particle to complete one oscillation is its period. Therefore, period of S.H.M. is the least time after which the motion will repeat itself. Thus, the motion will repeat itself after nT , where n is an integer.
- **Frequency:** Frequency of S.H.M. is the number of oscillations that a particle performs per unit time. S.I. unit of frequency is hertz or r.p.s (rotations per second). Its dimensions are $[\text{L}^0 \text{M}^0 \text{T}^{-1}]$.
- **Phase:** Phase of S.H.M. is its state of oscillation. Magnitude and direction of displacement of particle represent the phase.

Note: The period of simple harmonic motion *does not* depend on amplitude or energy or the phase constant.

Difference between Periodic and Simple Harmonic Motion

Periodic Motion	Simple Harmonic Motion
In the periodic motion, the displacement of the object may or may not be in the direction of the restoring force.	In the simple harmonic motion, the displacement of the object is always in the opposite direction of the restoring force.
The periodic motion may or may not be oscillatory.	Simple harmonic motion is always oscillatory.
Examples are the motion of the hands of a clock, the motion of the wheels of a car, etc.	Examples are the motion of a pendulum, motion of a spring, etc.

Velocity and Acceleration in Simple Harmonic Motion

A motion is said to be accelerated when its velocity keeps changing. But in simple harmonic motion, the particle performs the same motion again and again over a period of time. Do you think it is accelerated? Let's find out and learn how to calculate the acceleration and velocity of SHM.

Acceleration in SHM

We know what acceleration is. It is velocity per unit time. We can calculate the acceleration of a particle performing S.H.M. Let's learn how. The differential equation of linear S.H.M. is $d^2x/dt^2 + (k/m)x = 0$ where d^2x/dt^2 is the acceleration of the particle, x is the displacement of the particle, m is the mass of the particle and k is the force constant. We know that $k/m = \omega^2$ where ω is the angular frequency.

$$\text{Therefore, } d^2x/dt^2 + \omega^2 x = 0$$

Hence, acceleration of S.H.M. = $d^2x/dt^2 = -\omega^2 x$ The negative sign indicated that acceleration and displacement are in opposite direction of each other. Equation I is the expression of acceleration of S.H.M. Practically, the motion of a particle performing S.H.M. is accelerated because its velocity keeps changing either by a constant number or varied number.

Take a simple pendulum for example. When we swing a pendulum, it moves to and fro about its mean position. But after some time, it eventually stops and returns to its mean position. This type of simple harmonic motion in which velocity or amplitude keeps changing is damped simple harmonic motion.

Velocity in SHM

Velocity is distance per unit time. We can obtain the expression for velocity using the expression for acceleration. Let's see how. Acceleration $d^2x/dt^2 = dv/dt = dv/dx \times dx/dt$. But $dx/dt =$ velocity 'v'

Therefore, acceleration = $v(dv/dx)$

When we substitute equation II in equation I, we get, $v(dv/dx) = -\omega^2 x$.

$$\therefore vdv = -\omega^2 xdx$$

After integrating both sides, we get,

$$\int vdv = \int -\omega^2 xdx = -\omega^2 \int xdx$$

Hence, $v^2/2 = -\omega^2 x^2/2 + C$ where C is the constant of integration. Now, to find the value of C, let's consider boundary value condition. When a particle performing SHM is at the extreme position, displacement of the particle is maximum and velocity is zero. (a is the amplitude of SHM)

Therefore, At $x = \pm a$, $v = 0$

$$\text{And } 0 = -\omega^2 a^2/2 + C$$

$$\text{Hence, } C = \omega^2 a^2/2$$

Let's substitute this value of C in equation $v^2/2 = -\omega^2 x^2/2 + C$

$$\therefore v^2/2 = -\omega^2 x^2/2 + \omega^2 a^2/2$$

$$\therefore v^2 = \omega^2 (a^2 - x^2)$$

Taking square root on both sides, we get,

$$v = \pm \omega \sqrt{(a^2 - x^2)}$$

This equation is the expression of the velocity of S.H.M. The double sign indicates that when a particle passes through a given point in the positive direction of x, v is positive, and when it passes through the same point in opposite direction of x, v is negative.

Maximum and Minimum velocity

We know the velocity of a particle performing S.H.M. is given by, $v = \pm \omega \sqrt{a^2 - x^2}$. At mean position, $x = 0$. Therefore, $v = \pm \omega \sqrt{a^2 - 0^2} = \pm \omega \sqrt{a^2} = \pm a\omega$. Therefore, at mean position, velocity of the particle performing S.H.M. is maximum which is $V_{\max} = \pm a\omega$. At extreme position, $x = \pm a$

Therefore, $v = \pm \omega \sqrt{a^2 - x^2} = \omega \times 0 = 0$. Therefore, at extreme position, velocity of the particle performing S.H.M. is minimum which is $V_{\min} = 0$

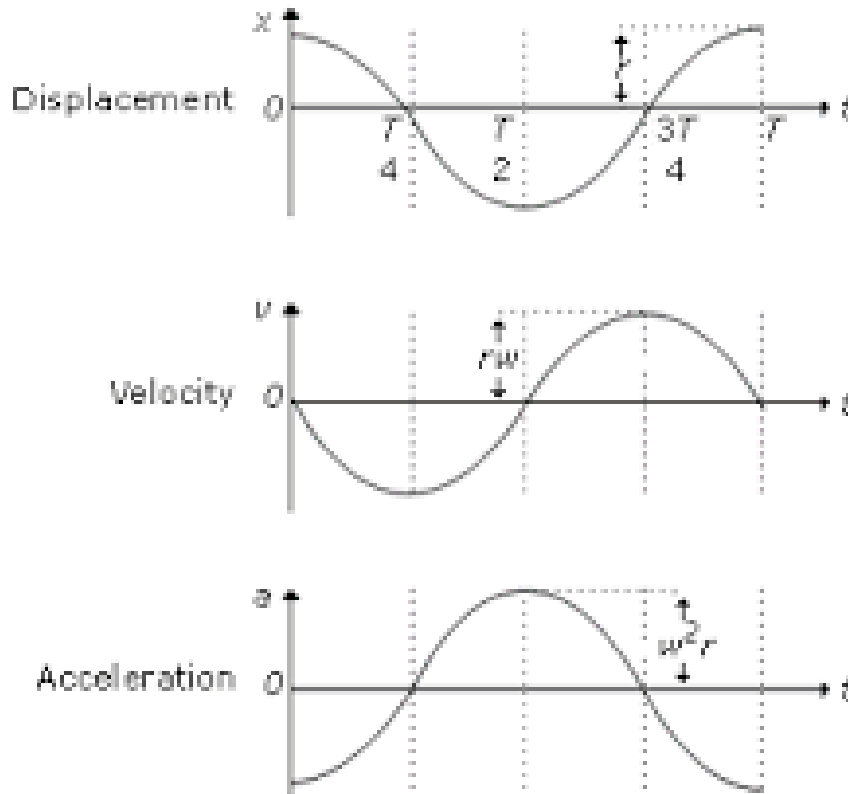

Solved Examples For You

Q: What is the value of acceleration at the mean position?

Solution: At mean position, $x = 0$

\therefore acceleration $= -\omega^2 x = -\omega^2 \times 0 = 0$. Therefore, the value of acceleration at the mean position is minimum and it is zero.

Energy in Simple Harmonic Motion

Each and every object possesses energy, either while moving or at rest. In the simple harmonic motion, the object moves to and fro along the same path. Do you think an object possesses energy while travelling the same path again and again? Yes, it is energy in simple harmonic motion. Let's learn how to calculate this energy and understand its properties.

Energy in Simple Harmonic Motion

The total energy that a particle possesses while performing simple harmonic motion is energy in simple harmonic motion. Take a pendulum for example. When it is at its mean

position, it is at rest. When it moves towards its extreme position, it is in motion and as soon as it reaches its extreme position, it comes to rest again. Therefore, in order to calculate the energy in simple harmonic motion, we need to calculate the kinetic and potential energy that the particle possesses.

Kinetic Energy (K.E.) in S.H.M

Kinetic energy is the energy possessed by an object when it is in motion. Let's learn how to calculate the kinetic energy of an object. Consider a particle with mass m performing simple harmonic motion along a path AB. Let O be its mean position. Therefore, $OA = OB = a$.

The instantaneous velocity of the particle performing S.H.M. at a distance x from the mean position is given by

$$v = \pm \omega \sqrt{a^2 - x^2}$$

$$\therefore v^2 = \omega^2 (a^2 - x^2)$$

$$\therefore \text{Kinetic energy} = \frac{1}{2} mv^2 = \frac{1}{2} m \omega^2 (a^2 - x^2)$$

$$\text{As, } k/m = \omega^2$$

$$\therefore k = m \omega^2$$

Kinetic energy = $\frac{1}{2} k (a^2 - x^2)$. The equations Ia and Ib can both be used for calculating the kinetic energy of the particle.

Potential Energy (P.E.) of Particle Performing S.H.M.

Potential energy is the energy possessed by the particle when it is at rest. Let's learn how to calculate the potential energy of a particle performing S.H.M. Consider a particle of mass m performing simple harmonic motion at a distance x from its mean position. You know the restoring force acting on the particle is $F = -kx$ where k is the force constant.

Now, the particle is given further infinitesimal displacement dx against the restoring force F . Let the work done to displace the particle be dw . Therefore, the work done dw during the displacement is

$$dw = -fdx = -(-kx)dx = kxdx$$

Therefore, the total work done to displace the particle now from 0 to x is

$$\int dw = \int kxdx = k \int x dx$$

$$\text{Hence Total work done} = \frac{1}{2} K x^2 = \frac{1}{2} m \omega^2 x^2$$

The total work done here is stored in the form of potential energy.

Therefore, Potential energy = $1/2 kx^2 = 1/2 m \omega^2 x^2$

Equations IIa and IIb are equations of potential energy of the particle. Thus, potential energy is directly proportional to the square of the displacement, that is P.E. $\propto x^2$.

Total Energy in Simple Harmonic Motion (T.E.)

The total energy in simple harmonic motion is the sum of its potential energy and kinetic energy.

Thus,

$$\text{T.E.} = \text{K.E.} + \text{P.E.} = 1/2 k (a^2 - x^2) + 1/2 K x^2 = 1/2 k a^2$$

$$\text{Hence, T.E.} = E = 1/2 m \omega^2 a^2$$

Equation III is the equation of total energy in a simple harmonic motion of a particle performing the simple harmonic motion. As ω^2 , a^2 are constants, the total energy in the simple harmonic motion of a particle performing simple harmonic motion remains constant. Therefore, it is independent of displacement x .

$$\text{As } \omega = 2\pi f, E = 1/2 m (2\pi f)^2 a^2$$

$$\therefore E = 2m\pi^2 f^2 a^2$$

As 2 and π^2 constants, we have T.E. $\sim m$, T.E. $\sim f^2$, and T.E. $\sim a^2$

Thus, the total energy in the simple harmonic motion of a particle is:

- Directly proportional to its mass
- Directly proportional to the square of the frequency of oscillations and
- Directly proportional to the square of the amplitude of oscillation.

The law of conservation of energy states that energy can neither be created nor destroyed. Therefore, the total energy in simple harmonic motion will always be constant. However, kinetic energy and potential energy are interchangeable. Given below is the graph of kinetic and potential energy vs instantaneous displacement.

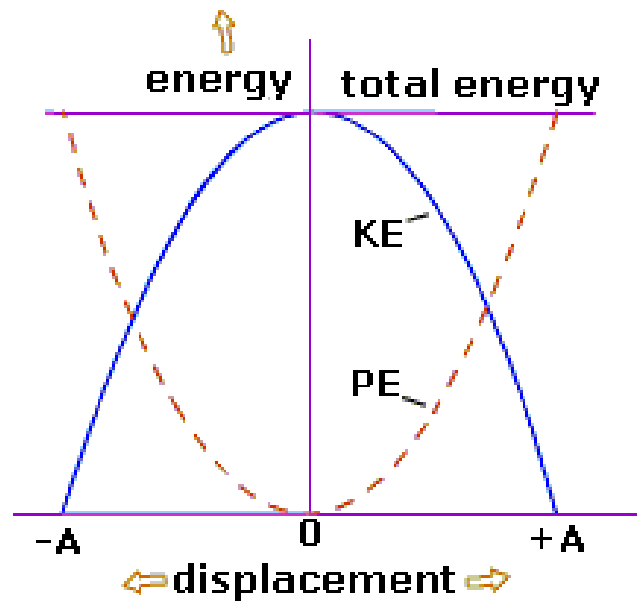

In the graph, we can see that,

- At the mean position, the total energy in simple harmonic motion is purely kinetic and at the extreme position, the total energy in simple harmonic motion is purely potential energy.
- At other positions, kinetic and potential energies are interconvertible, and their sum is equal to $\frac{1}{2} k a^2$.
- The nature of the graph is parabolic.

Here's a Solved Question for You

Q: At the mean position, the total energy in simple harmonic motion is _____

- a) purely kinetic b) purely potential c) zero d) None of the above

Answer: a) purely kinetic. At the mean position, the velocity of the particle in S.H.M. is maximum and displacement is minimum, that is, $x=0$. Therefore, P.E. $=\frac{1}{2} K x^2 = 0$ and K.E. $= \frac{1}{2} k (a^2 - x^2) = \frac{1}{2} k (a^2 - 0^2) = \frac{1}{2} k a^2$. Thus, the total energy in simple harmonic motion is purely kinetic.

Interference of light

The most certain indication of a wave is interference. This wave characteristic is most prominent when the wave interacts with an object that is not large compared with the wavelength. Interference is observed for water waves, sound waves, light waves, and, in fact, all types of waves.

When two light waves from different coherent sources meet together, then the distribution of energy due to one wave is disturbed by the other.

This modification in the distribution of light energy due to super-position of two light waves is called "Interference of light".



Conditions for interference

1- Interference takes place only between waves with the same wavelength

light source that has a single wavelength is called *monochromatic*, which means single colored.

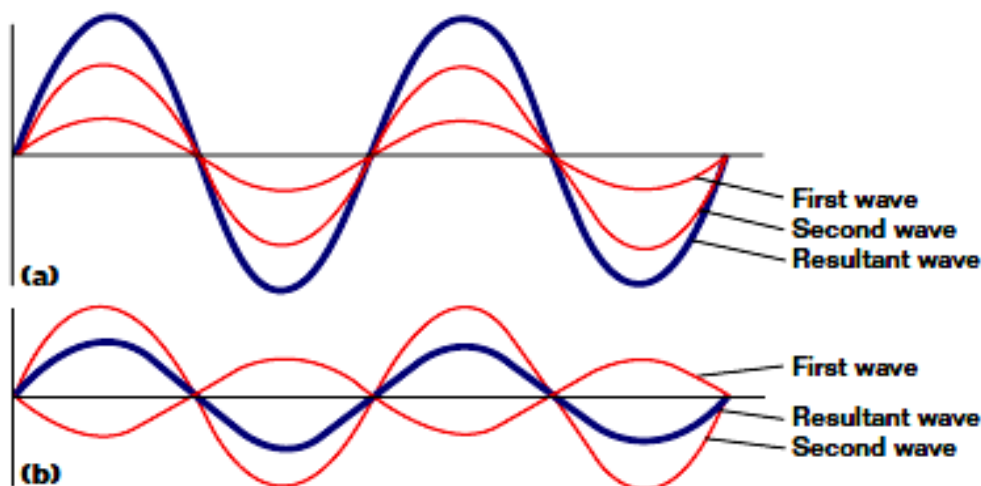

2- Waves must have a constant phase difference for interference to be observed.

Waves are said to have when the phase difference between two waves is constant and the waves do not shift relative to each other as time passes. Sources of such waves are said to be *coherent*.

3- The two sources of light should be very close to each other.

Types of interference

Constructive Interference: If phase difference between two waves is zero than the interference wave must have Phase difference $2n\pi$ where n belongs to whole number and path difference $n\lambda$ where n is a whole number.

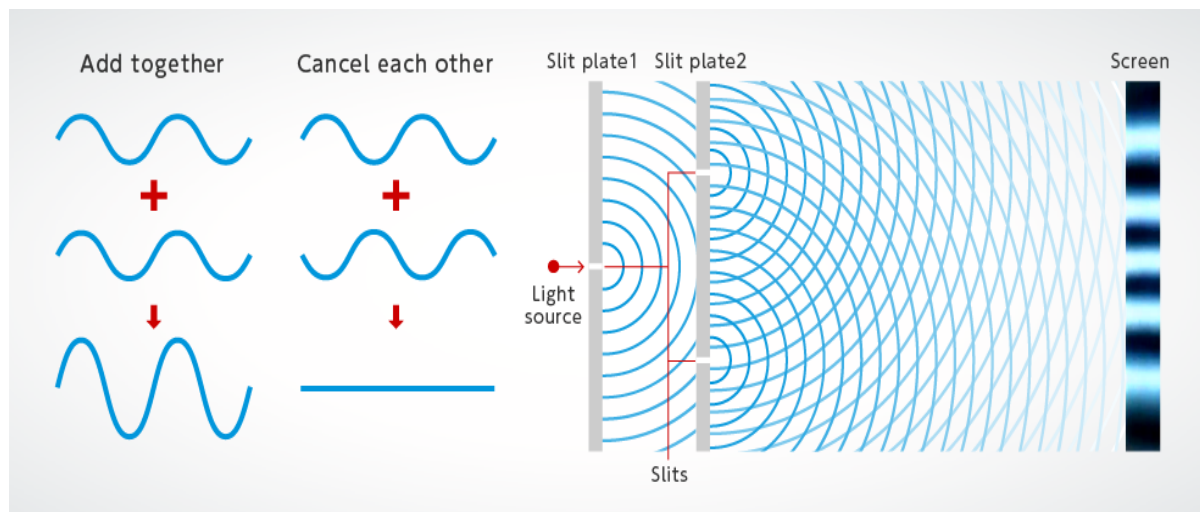

Destructive Interference: If phase difference between two waves are zero than the interference wave must have Phase difference $(2n-1)\pi$ where n belongs to whole number and path difference $(n+1/2)\lambda$ where n is a whole number.

Young's Double-Slit Experiment

Interference in light waves from two sources was first demonstrated by Thomas Young in 1801. Plane light waves arrive at a barrier that contains two slits S_1 and S_2 . The light from S_1 and S_2 produces on a viewing screen a visible pattern of bright and dark parallel bands called **fringes**.

When the light from S_1 and that from S_2 both arrive at a point on the screen such that constructive interference occurs at that location, a bright fringe appears. When the light from the two slits combines destructively at any location on the screen, a dark fringe result.

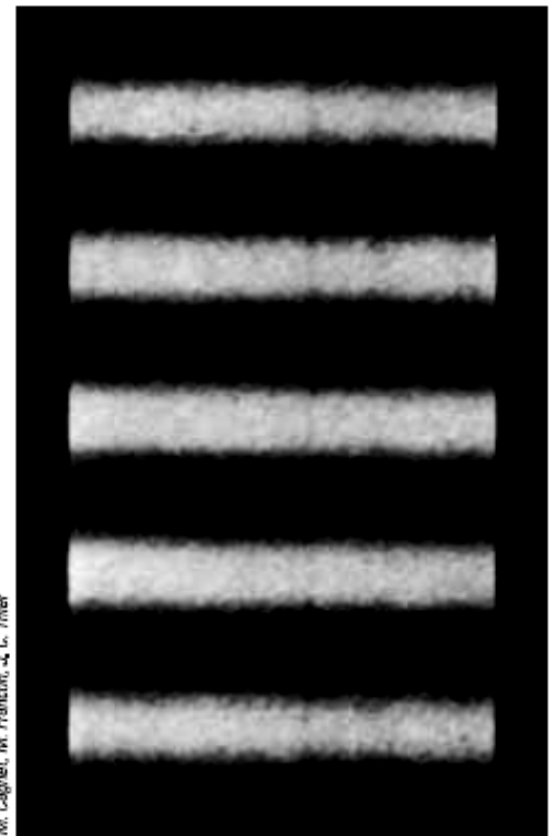
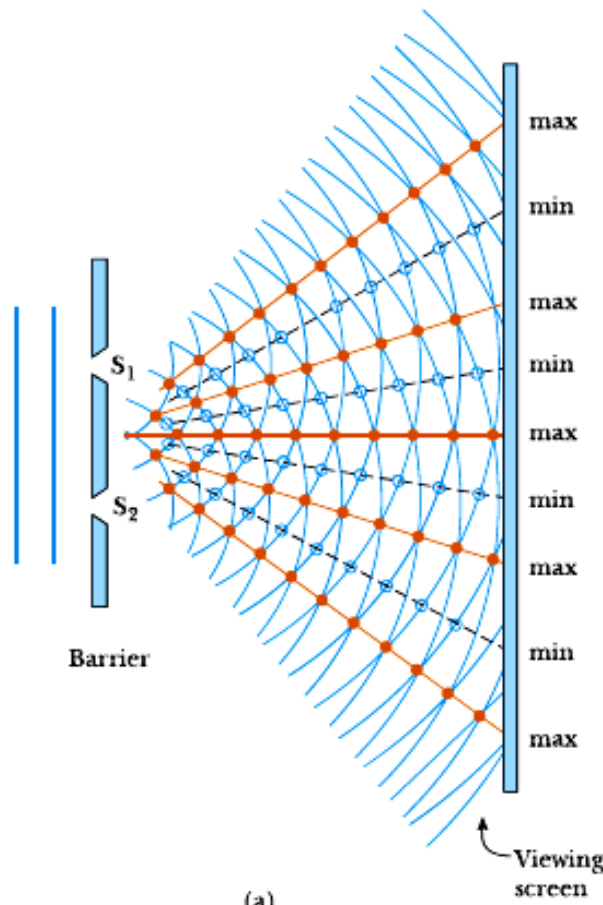

M. Cagnat, M. Francon, J. C. Thier

(a)

(b)

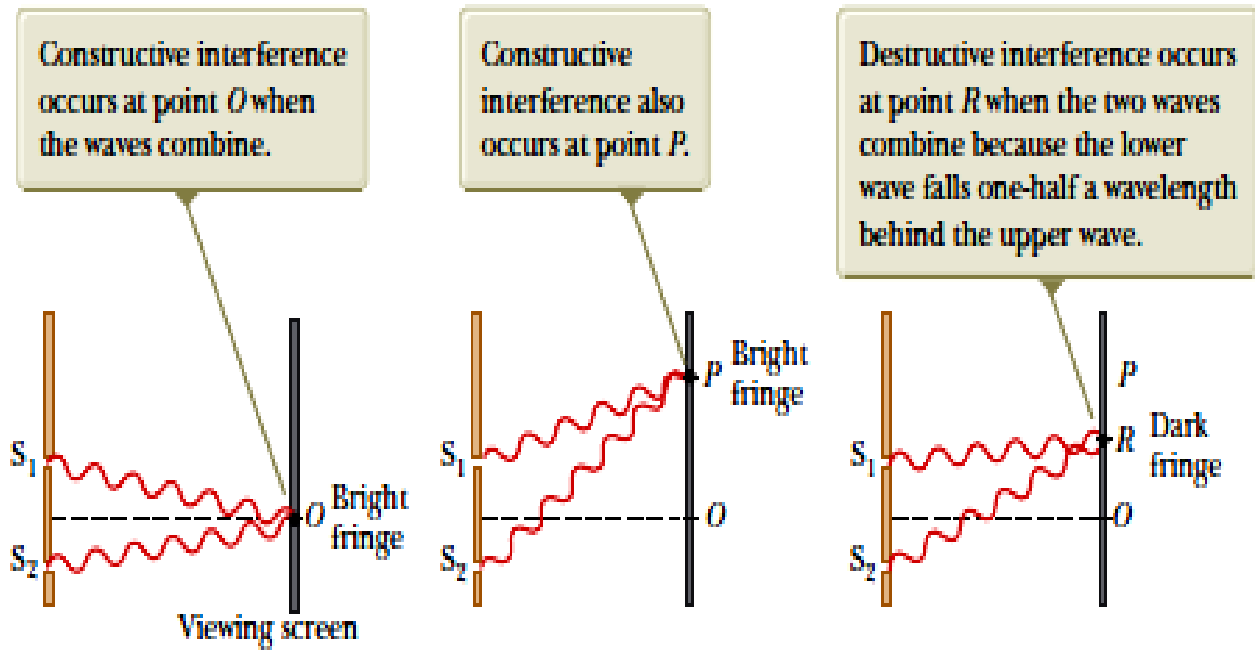

Analysis Model: Waves in Interference

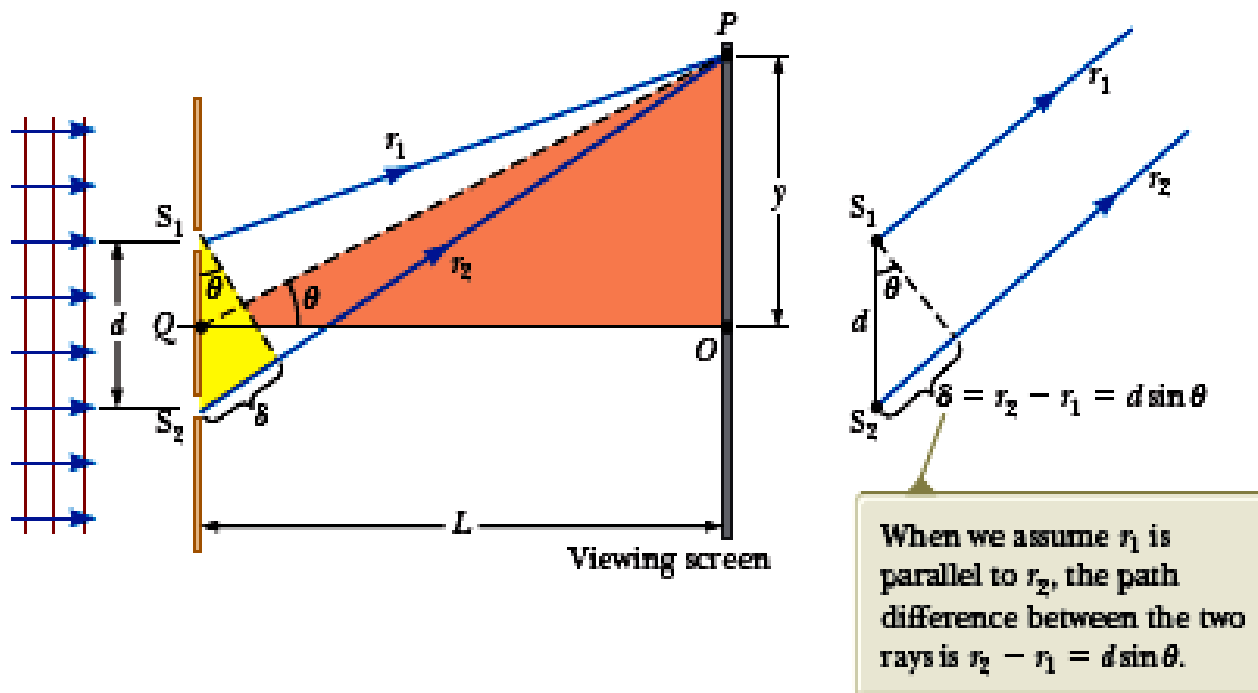

The viewing screen is located a perpendicular distance L from the barrier containing two slits, S_1 and S_2 . These slits are separated by a distance d , and the source is monochromatic. To reach any arbitrary point P in the upper half of the screen, a wave from the lower slit must travel farther than a wave from the upper slit. The extra distance traveled from the lower slit is the **path difference** δ (Greek letter delta).

If we assume the rays labeled r_1 and r_2 are parallel which is approximately true if L is much greater than d , then δ is given by:

$$\delta = r_2 - r_1 = d \sin \theta$$

The value of δ determines whether the two waves are in phase when they arrive at point P . If δ is either zero or some integer multiple of the wavelength, the two waves are in phase at point P and constructive interference results. Therefore, the condition for bright fringes, or constructive interference, at point P is:

$$d \sin \theta_{\text{bright}} = m\lambda \quad m = 0, \pm 1, \pm 2, \dots$$

The number m is called the order number.

For constructive interference, the order number is the same as the number of wavelengths that represents the path difference between the waves from the two slits.

The central bright fringe at $\theta_{\text{bright}} = 0$ is called the *zeroth-order maximum*.

The first maximum on either side, where $m = \pm 1$, is called the *first-order maximum*, and so forth.

When δ is an odd multiple of $\lambda/2$, the two waves arriving at point P are 180° out of phase and give rise to destructive interference. Therefore, the condition for dark fringes, or **destructive interference**, at point P is:

$$d \sin \theta_{\text{dark}} = \left(m + \frac{1}{2}\right)\lambda \quad m = 0, \pm 1, \pm 2, \dots$$

These equations provide the *angular* positions of the fringes. It is also useful to obtain expressions for the *linear* positions measured along the screen from O to P . From the triangle OPQ :

$$\tan \theta = \frac{y}{L}$$

Using this result, the linear positions of bright and dark fringes are given by:

$$y_{\text{bright}} = L \tan \theta_{\text{bright}} \quad y_{\text{dark}} = L \tan \theta_{\text{dark}}$$

When the angles to the fringes are small, the positions of the fringes are linear near the center of the pattern.

That can be verified by noting that for small angles, $\tan \theta \approx \sin \theta$, from so the positions of the bright fringes as $y_{\text{bright}} = L \sin \theta_{\text{bright}}$.

$$y_{\text{bright}} = L \frac{m\lambda}{d} \quad (\text{small angles})$$

This result shows that y_{bright} is linear in the order number m , so the fringes are equally spaced for small angles. Similarly, for dark fringes,

$$y_{\text{dark}} = L \frac{\left(m + \frac{1}{2}\right)\lambda}{d} \quad (\text{small angles})$$

Quick Quiz

1- Which of the following causes the fringes in a two-slit interference pattern to move farther apart?

- (a) decreasing the wavelength of the light
- (b) decreasing the screen distance L

- (c) decreasing the slit spacing d
- (d) Immersing the entire apparatus in water

2- In a two-slit interference pattern projected on a screen, are the fringes equally spaced on the screen

- (a) Everywhere
 (b) only for large angles
 (c) only for small angles?

3- If the distance between the slits is doubled in young's experiment, what happens to the width of the central maximum?

- (a) The width is doubled.
 (b) The width is unchanged.
 (c) The width is halved.

4- A Young's double-slit experiment is performed with three different colors of light: red, green, and blue. Rank the colors by the distance between adjacent bright fringes, from smallest to largest.

- (a) red, green, blue
 (b) green, blue, red
 (c) blue, green, red

Example

A viewing screen is separated from a double slit by 4.80 m. The distance between the two slits is 0.030 0 mm. Monochromatic light is directed toward the double slit and forms an interference pattern on the screen. The first dark fringe is 4.50 cm from the center line on the screen.

- (A) Determine the wavelength of the light.
 (B) Calculate the distance between adjacent bright fringes.

Solution:

(A) Because $L \gg y$, the angles for the fringes are small.

$$y_{\text{dark}} = L \frac{(m + \frac{1}{2})\lambda}{d} \quad (\text{small angles})$$

$$\lambda = \frac{y_{\text{dark}} d}{(m + \frac{1}{2})L} = \frac{(4.50 \times 10^{-2} \text{ m})(3.00 \times 10^{-5} \text{ m})}{(0 + \frac{1}{2})(4.80 \text{ m})}$$

$$= 5.62 \times 10^{-7} \text{ m} = \mathbf{562 \text{ nm}}$$

(B) the distance between adjacent bright fringes.

$$y_{m+1} - y_m = L \frac{(m+1)\lambda}{d} - L \frac{m\lambda}{d}$$

$$= L \frac{\lambda}{d} = 4.80 \text{ m} \left(\frac{5.62 \times 10^{-7} \text{ m}}{3.00 \times 10^{-5} \text{ m}} \right)$$

$$= 9.00 \times 10^{-2} \text{ m} = \mathbf{9.00 \text{ cm}}$$

A light source emits visible light of two wavelengths: $\lambda = 430 \text{ nm}$ and $\lambda' = 510 \text{ nm}$. The source is used in a double-slit.

interference experiment in which $L = 1.50 \text{ m}$ and $d = 0.0250 \text{ mm}$. Find the separation distance between the third order bright fringes for the two wavelengths.

Solution:

We need to find the fringe positions corresponding to these two wavelengths and subtract them:

$$\Delta y = y'_{\text{bright}} - y_{\text{bright}} = L \frac{m\lambda'}{d} - L \frac{m\lambda}{d} = \frac{Lm}{d} (\lambda' - \lambda)$$

$$\Delta y = \frac{(1.50 \text{ m})(3)}{0.0250 \times 10^{-3} \text{ m}} (510 \times 10^{-9} \text{ m} - 430 \times 10^{-9} \text{ m})$$

$$= 0.0144 \text{ m} = \mathbf{1.44 \text{ cm}}$$

What if we examine the entire interference pattern due to the two wavelengths and look for overlapping fringes? Are there any locations on the screen where the bright fringes from the two wavelengths overlap exactly?

Find such a location by setting the location of any bright fringe due to λ' equal to one due to λ

$$L \frac{m\lambda}{d} = L \frac{m'\lambda'}{d} \rightarrow \frac{m'}{m} = \frac{\lambda}{\lambda'}$$

$$\frac{m'}{m} = \frac{430 \text{ nm}}{510 \text{ nm}} = \frac{43}{51}$$

Therefore, the 51st fringe of the 430-nm light overlaps with the 43rd fringe of the 510-nm light.

To find the value of y for these fringes:

$$y = (1.50 \text{ m}) \left[\frac{51(430 \times 10^{-9} \text{ m})}{0.0250 \times 10^{-3} \text{ m}} \right] = 1.32 \text{ m}$$

The distance between the two slits is 0.030 mm. The second-order bright fringe ($m=2$) is measured on a viewing screen at an angle of 2.15° from the central maximum. Determine the wavelength of the light.

SOLUTION

1. DEFINE

Given: $d = 3.0 \times 10^{-5} \text{ m}$ $m = 2$ $\theta = 2.15^\circ$

Unknown: $\lambda = ?$

Diagram:

2. PLAN

Choose an equation or situation: Use the equation for constructive interference.

$$d \sin \theta = m\lambda$$

Rearrange the equation to isolate the unknown:

$$\lambda = \frac{d \sin \theta}{m}$$

3. CALCULATE

Substitute the values into the equation and solve:

$$\lambda = \frac{(3.0 \times 10^{-5} \text{ m})(\sin 2.15^\circ)}{2}$$

$$\lambda = 5.6 \times 10^{-7} \text{ m} = 5.6 \times 10^2 \text{ nm}$$

$$\lambda = 5.6 \times 10^2 \text{ nm}$$

4. EVALUATE

This wavelength of light is in the visible spectrum. The wavelength corresponds to light of a yellow-green color.

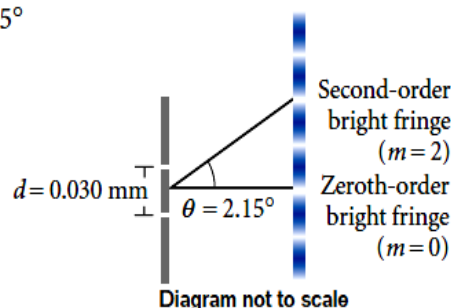

CALCULATOR SOLUTION

Because the minimum number of significant figures for the data is two, the calculator answer 5.627366×10^{-7} should be rounded to two significant figures.

A double-slit source with slit separation 0.2 mm is located 1.2 m from a screen. The distance between successive bright fringes on the screen is measured to be 3.30 mm. What is the wavelength of the light?

$$\Delta = (y_B)_{m+1} - (y_B)_m = \frac{\lambda s(m+1)}{a} - \frac{\lambda s(m)}{a} = \frac{\lambda s}{a}$$

$$\therefore \Delta y = \frac{\lambda s}{a}, \text{ so that } \lambda = \frac{(\Delta y)a}{s}, \text{ giving}$$

$$\lambda = \frac{(3.30 \times 10^{-3} \text{ m})(2 \times 10^{-4} \text{ m})}{1.2 \text{ m}} = 5.5 \times 10^{-7} \text{ m} = 550 \times 10^{-9} \text{ m}$$

So the wavelength is about 550 nm and the light is yellowish green in color.

Remember

The “bright fringes” correspond to regions of **constructive interference**. This will occur at a position on the viewing screen when $\delta = \pm m\lambda$:

$$\boxed{\delta = d \sin \theta_{\text{bright}} = m\lambda, \quad m = 0, \pm 1, \pm 2, \dots} \quad (\text{XIII-2})$$

- i) The number m is called the **order number**.
- ii) The central bright fringe at $\theta_{\text{bright}} = 0$ is called the *zeroth-order maximum*.
- iii) The first maximum on either side, where $m = \pm 1$, is called the *first-order maximum*, and so forth.

The “dark fringes” correspond to regions of **destructive interference**. This will occur at a position on the viewing screen when the waves are 180° out of phase (*i.e.*, δ is an odd multiple of $\lambda/2$):

$$\delta = d \sin \theta_{\text{dark}} = \left(m + \frac{1}{2}\right) \lambda, \quad m = 0, \pm 1, \pm 2, \dots$$

(XIII-3)

- i) Here, the first dark fringe occurs at $m = 0$ giving a path difference of $\lambda/2$.
- ii) The second dark fringe occurs at $m = 1$ giving a path difference of $3\lambda/2$, and so on.

Exercises

- 1- What is the necessary condition for a path length difference between two waves that interfere constructively? destructively?
- 2- If white light is used instead of monochromatic light to demonstrate interference, how does the interference pattern change?
- 3- If the distance between two slits is 0.0550 mm, find the angle between the first order and second-order bright fringes for yellow light with a wavelength of 605 nm.
- 4- double-slit interference experiment is performed with blue-green light from an argon-gas laser. The separation between the slits is 0.50 mm, and the first-order maximum of the interference pattern is at an angle of 0.059° from the center of the pattern. What is the wavelength of argon laser light?
- 5- Light falls on a double slit with slit separation of 2.02×10^{-6} m, and the first bright fringe is seen at an angle of 16.5° relative to the central maximum. Find the wavelength of the light.
- 6- A pair of narrow parallel slits separated by a distance of 0.250 mm is illuminated by the green component from a mercury vapor lamp ($\lambda = 546.1$ nm). Calculate the angle from the central maximum to the first bright fringe on either side of the central maximum.

The difference between Superposition and Interference

Superposition is simply the term used to describe the fact that when two waves meet the resulting amplitude is the sum of the amplitudes of the two waves. It occurs for all waves. A detector can only measure the amplitude of the resultant wave. **Interference** is the special case where *coherent* waves meet. Under the correct conditions you can get the constructive and destructive waves.

$$\text{Phase difference } (\phi) = \frac{2\pi}{\lambda} \times \text{path difference } (x)$$

$$\Rightarrow \phi = \frac{2\pi x}{\lambda} \Rightarrow x = \frac{\phi \lambda}{2\pi}$$

$$\text{Phase difference } (\phi) = \frac{2\pi}{T} \times \text{time difference } (t)$$

$$\Rightarrow \phi = \frac{2\pi t}{T} \Rightarrow t = \frac{T\phi}{2\pi}$$

$$\text{Time difference } (t) = \frac{T}{\lambda} \times \text{path difference } (x)$$

$$\Rightarrow t = \frac{Tx}{\lambda} \Rightarrow x = \frac{\lambda t}{T}$$

(i) For a wave, velocity

$$v = \text{frequency } (n) \times \text{wavelength } (\lambda)$$

$$\Rightarrow v = n\lambda$$

(ii) Angular speed,

$$\omega = 2\pi n = \frac{2\pi}{T}, = \frac{2\pi v}{\lambda}$$

PHASE AND PATH DIFFERENCE

Phase: Phase of a vibrating particle at any instant indicates its state of vibration.

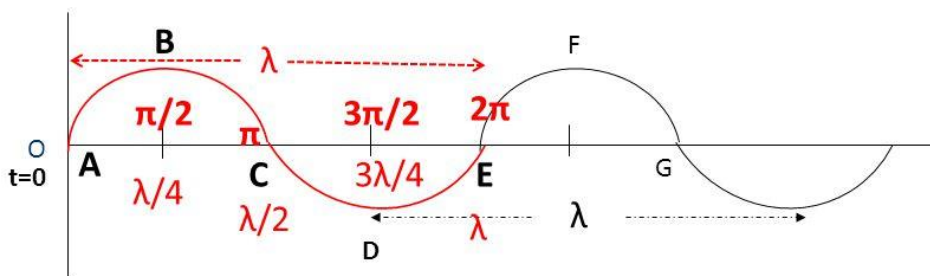

Phase may be expressed in terms of angle as a fraction of 2π .

Path difference λ corresponds to phase difference of 2π .

$$\frac{\text{Phase difference}}{2\pi} = \frac{\text{Path difference}}{\lambda}$$

Intensity Distribution of the Double-Slit Interference Pattern

Note that the edges of the bright fringes are not sharp there is a gradual change from bright to dark. So far we have discussed the locations of only the centers of the bright and dark fringes on a distant screen. Let us now direct our attention to the intensity of the light at other points between the positions of maximum constructive and destructive interference. In other words, we now calculate the distribution of light intensity associated with the double-slit interference pattern.

Again, suppose that the two slits represent coherent sources of sinusoidal waves such that the two waves from the slits have the same angular frequency ω and a constant phase difference.

The total magnitude of the electric field at point P on the screen in the figure is the superposition of the two waves.

Assuming that the two waves have the same amplitude E_0 , we can write the magnitude of the electric field at point P due to each wave separately as:

$$E_1 = E_0 \sin \omega t \quad \text{and} \quad E_2 = E_0 \sin(\omega t + \phi)$$

Although the waves are in phase at the slits, *their phase difference ϕ at P depends on the path difference $\delta = r_2 - r_1 = d \sin \theta$*

A path difference of λ (for constructive interference) corresponds to a phase difference of 2π rad. A path difference of δ is the same fraction of λ as the phase difference is ϕ of 2π . We can describe this mathematically with the ratio:

$$\frac{\delta}{\lambda} = \frac{\phi}{2\pi}$$

Which gives us

$$\phi = \frac{2\pi}{\lambda} \delta = \frac{2\pi}{\lambda} d \sin \theta$$

Using the superposition principle, we can obtain the magnitude of the resultant electric field at point P :

$$E_P = E_1 + E_2 = E_0 [\sin \omega t + \sin(\omega t + \phi)]$$

To simplify this expression, we use the trigonometric identity

$$\sin A + \sin B = 2 \sin \left(\frac{A + B}{2} \right) \cos \left(\frac{A - B}{2} \right)$$

Taking

$$A = \omega t + \phi \quad \text{and} \quad B = \omega t$$

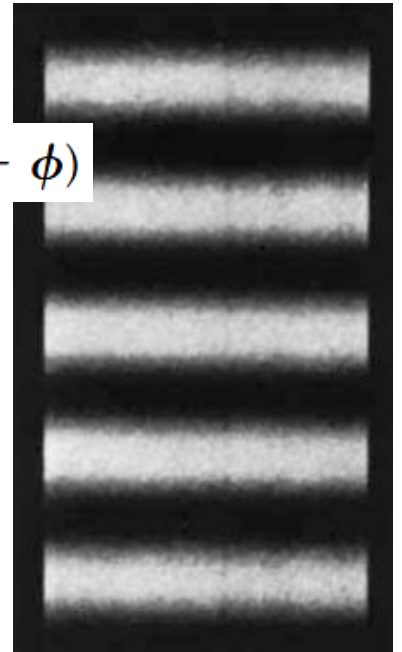

$$E_P = 2E_0 \cos\left(\frac{\phi}{2}\right) \sin\left(\omega t + \frac{\phi}{2}\right)$$

The intensity of a wave is proportional to the square of the resultant electric field magnitude at that point

$$I \propto E_P^2 = 4E_0^2 \cos^2\left(\frac{\phi}{2}\right) \sin^2\left(\omega t + \frac{\phi}{2}\right)$$

Most light-detecting instruments measure time-averaged light intensity, and the time

averaged value of $\sin^2\left(\omega t + \frac{\phi}{2}\right) = 1/2$

$$I = I_{\max} \cos^2\left(\frac{\phi}{2}\right) \quad \phi = \frac{2\pi}{\lambda} \delta = \frac{2\pi}{\lambda} d \sin \theta$$

$$I = I_{\max} \cos^2\left(\frac{\pi d \sin \theta}{\lambda}\right)$$

$\sin \theta \approx y/L$ for small values of θ

$$I \approx I_{\max} \cos^2\left(\frac{\pi d}{\lambda L} y\right)$$

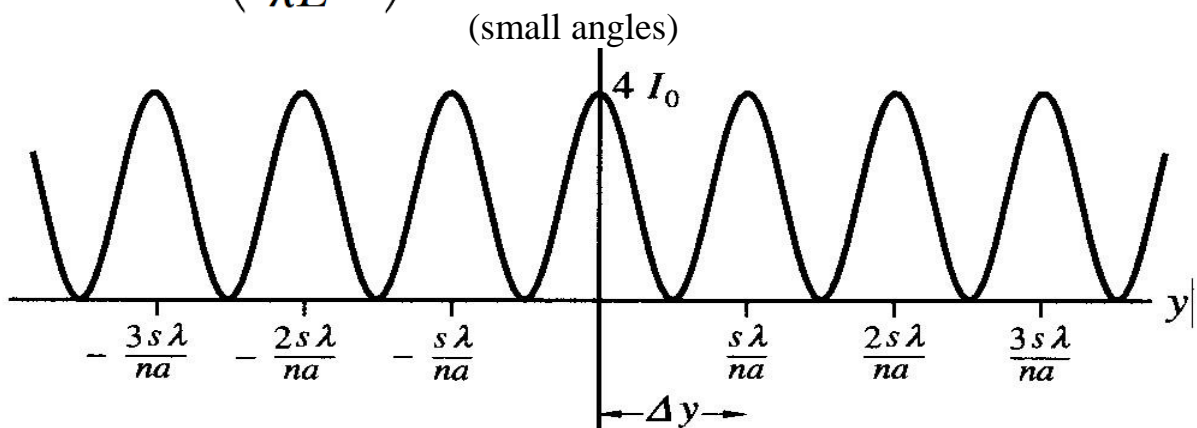

Change of Phase Due to Reflection

An electromagnetic wave undergoes a phase change of 180° upon reflection from a medium that has an index of refraction higher than the one in which the wave was traveling.

Young's method for producing two coherent light sources involves illuminating a pair of slits with a single source. Another simple, yet ingenious, arrangement for producing an interference pattern with a single light source is known as *Lloyd's mirror*.

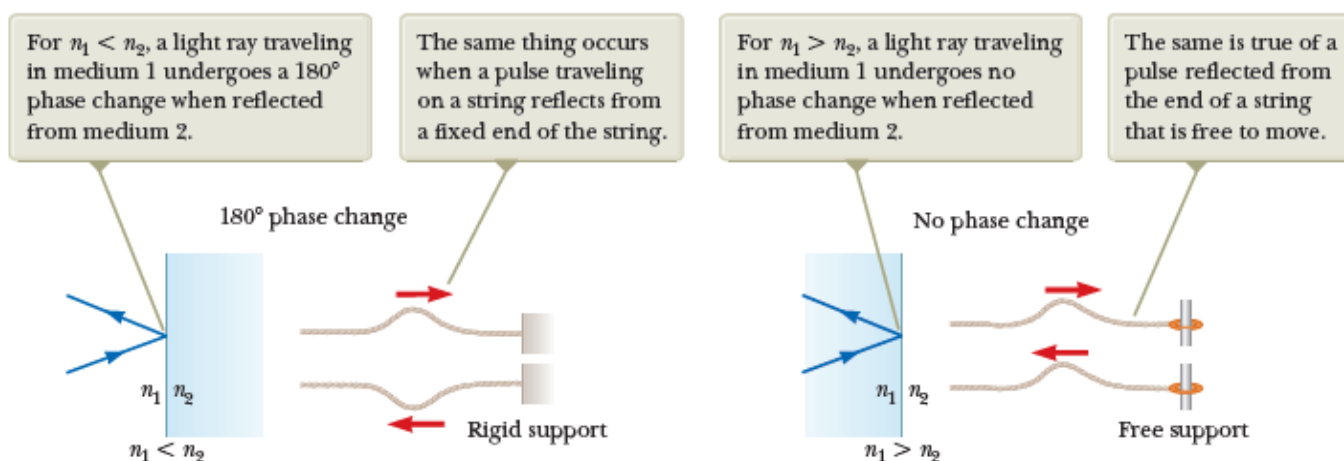

Lloyd's Mirror:

Lloyd's mirror provides a coherent secondary source S_1 (formed by reflection from the mirror) from which light reaches the screen to interfere with light reaching the screen directly from S . A hidden phase change of π occurs upon reflection, and this corresponds to a $\lambda/2$ path length change which must be included in calculations.

Interference in Thin Films

Thin films deposited on optical components—such as camera lenses—reduce reflection and enhance the intensity of the transmitted light. Thin coatings on windows can enhance the reflectivity for infrared radiation while having less effect on the visible radiation.

It is possible to reduce the heating effect of sunlight on a building.

Interference effects are commonly observed in thin films, such as the thin surface of a soap bubble or thin layers of oil on water. The varied colors observed when incoherent white light is incident on such films result from the interference of waves reflected from the two surfaces of the film.

- Consider a film of uniform thickness t and index of refraction n .
- Assume the light rays traveling in air are nearly normal to the two surfaces of the film. To determine whether the reflected rays interfere constructively or destructively,

We first note the following facts:

1. An electromagnetic wave traveling from a medium of index of refraction n_1 toward a medium of index of refraction n_2 undergoes a 180° phase change on reflection when $n_2 > n_1$. There is no phase change in the reflected wave if $n_2 < n_1$.

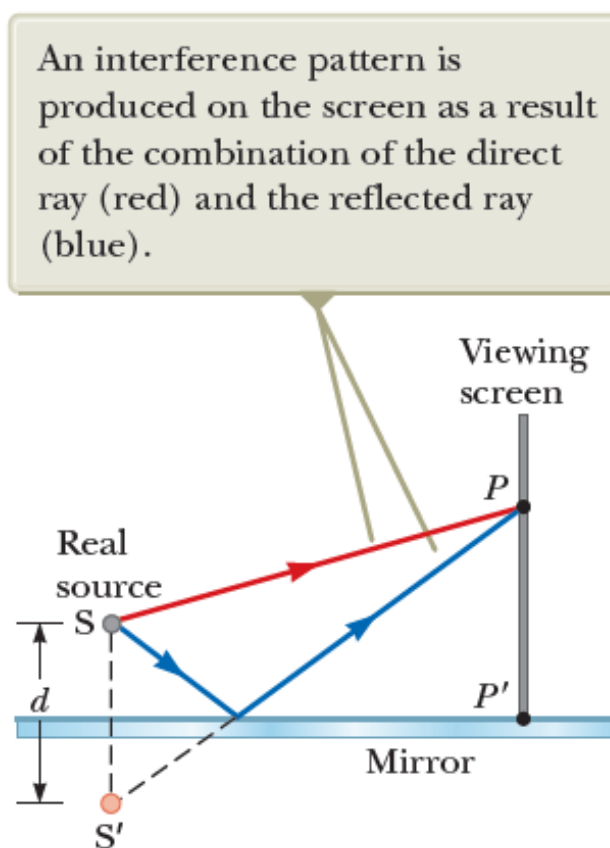

2. The wavelength of light λ_n in a medium with index of refraction n is

where λ is the wavelength of light in vacuum.

Suppose we have a thin film (a soap film or thin film of air between two glass plates) is viewed by light reflected from a source S .

Waves reflected from the front surface (r_1) and back surface (r_2) interfere and enter the eye.

- The incident ray 'i' from the source enters the eye as ray r_1 after reflection from the front surface of the film at 'a'.
- The incident ray 'i' also enters the film at 'a' as refracted ray and is reflected from the back surface of the film at 'b'.

It then emerges from the front surface of the film at 'c' and also enters the eye, as ray r_2 .

Interference in light reflected from a thin film is due to a combination of rays r_1 and r_2 .

As the waves originated from the same source by division of amplitude, hence they are coherent, and they are close together. The region ac looks bright or dark for an observer depends on the phase difference between waves of rays r_1 and r_2 .

As r_1 and r_2 have travelled over paths of different lengths, have traversed different media, and have suffered different kinds of reflections at 'a' and 'b'.

The phase difference between two reflected rays r_1 and r_2 determine whether they interfere constructively or destructively.

- To obtain Equations for thin film Interference, let us simplify by assuming near -normal incidence $\theta_i=0$.
- The ' r_2 ' travels a longer path ($2d$) than ' r_1 ', as ' r_2 ' travels twice through the film before reaching the eye.
- The path difference due to the travel of ray r_2 through the film is approximately ' $2d$ '.
- Other possible contributions to the total path difference between r_1 and r_2 : the phase difference of π (or path difference of one-half wavelength) that might occur on reflection at the **front/back surface** of the film.
- Generally, the interference from a thin soap film of index of refraction ' n ' surrounded by air, we must add the extra half wavelength for the front surface reflection, but not for the back surface.

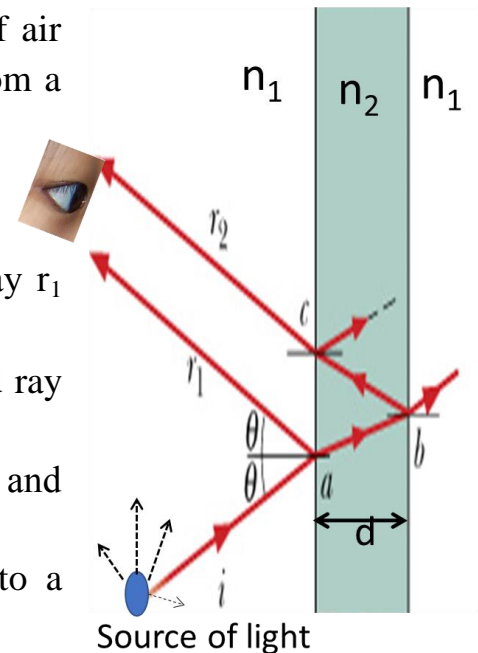

A general equation for thin film Interference:

The path difference between rays r_1 and r_2 is:

$$\text{Path difference} = 2d + \overset{?}{\lambda_n/2} + \overset{?}{\lambda_n/2} \dots\dots\dots(1)$$

Front surface

Back surface

• **For constructive interference**

The total path difference=

$$2d + \lambda_n/2 = m\lambda_n \dots(\text{maxima})$$

where $m=1,2,3,\dots\dots\dots$

Where we have dropped the $m=0$ solution because it is not physically meaningful.

• **For destructive interference**

The total path difference:

$$= 2d + \lambda_n/2 = (m+1/2) \lambda_n \dots\dots\dots (\text{minima})$$

where $m=0,1,2,3,\dots\dots$

Note: These equations apply when the index of refraction of the film is greater than the index of refraction of the material on either side.

THIN FILM INTERFERENCE -WEDGE SHAPED FILM

A thin wedge of air film can be formed by two glasses slides on each other at one edge and separated by a thin spacer (a thin wire or a thin sheet) at the opposite edge.

A thin film having zero thickness at one end a progressively increasing to a particular thickness at the other end is called a wedge.

- When a parallel beam of monochromatic light falls normally on a wedge-shaped film part of it is reflected from upper surface and some part from lower surface (division of amplitude).
- Ray BC reflected from the top –NO phase change.
- Ray DE (the **back surface** reflection) undergoes a π phase change and $\lambda/2$ (half wave length) at the air to glass boundary due to reflection.
- These two coherent waves superpose-producing constructive and destructive interferences, the positions of which depend on the thickness of the film.
- **Constructive Interference**

The total path difference:

$$\text{Path difference} = 2d + \lambda_n/2 = m\lambda_n \dots\dots(\text{maxima})$$

where $m=1,2,3,\dots\dots$

$m=0$ dropped, physically not meaningful.

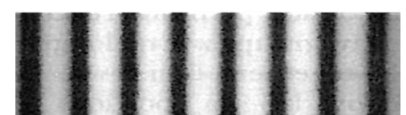
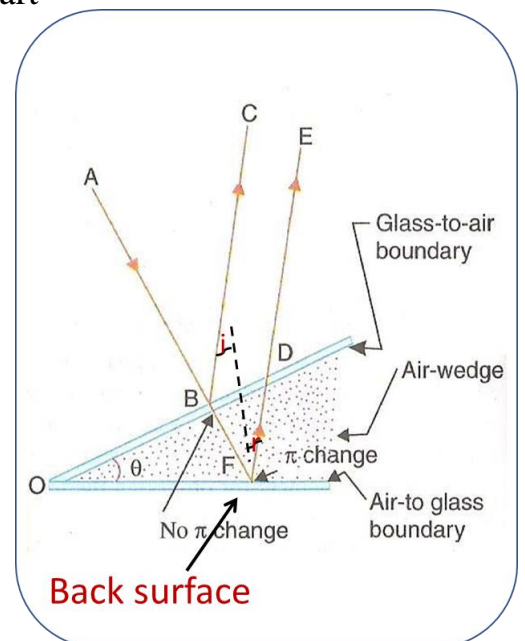

• **Destructive Interference**

$$\text{Path difference} = 2d + \lambda_n/2 = (m+1/2) \lambda_n \dots(\text{minima})$$

where $m=0,1,2,3,\dots$

Examples

1- A soap film ($n=1.33$) in air is **320 nm thick**. If it is illuminated with white light at normal incidence, what color will it appear to be in reflected light?

Solution:

The wavelengths which are maximally reflected are constructively interfered.

$$2d + \frac{\lambda_n}{2} = m\lambda_n \quad (\text{maxima})$$

$$\lambda = \frac{2nd}{(m - \frac{1}{2})} = \frac{851 \text{ nm}}{(m - \frac{1}{2})}$$

Constructive interference maxima occur for the following wavelengths:

1702 nm ($m=1$), **567 nm ($m=2$)**,
340 nm ($m=3$) and so on.

Only the maximum corresponding to $m=2$ lies in the visible region (between about 400 nm and 700 nm); light of wavelength 567 nm appears yellow green.

2- Lenses are often coated with thin films of transparent substances such as MgF_2 ($n=1.38$) to reduce the reflection from the glass surface. How thick a coating is needed to produce a minimum reflection at the center of the visible spectrum ($\lambda=550 \text{ nm}$)?

Given: $\lambda=550 \text{ nm}$, $n=1.38$

Minimum reflection: (Destructive interference)

Thickness of coating: $d=?$

Solution

Light strikes the lens at near-normal incidence (θ).

For both the front and back surfaces of the MgF_2 film the reflection have additional path difference ($\lambda/2$).

The path difference for destructive interference is therefore Path difference:

$$2nd + \lambda_n/2 + \lambda_n/2 = (m+1/2) \lambda_n \dots(\text{minima})$$

Where $m=1,2,3,\dots$

We seek the minimum thickness for destructive interference. For $m=1$, we obtain:

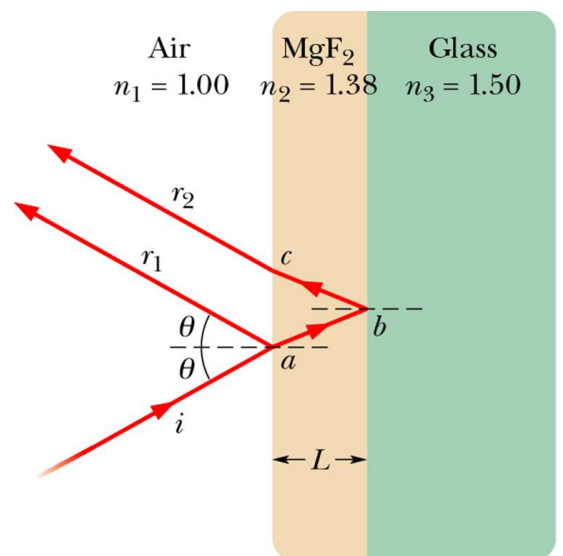
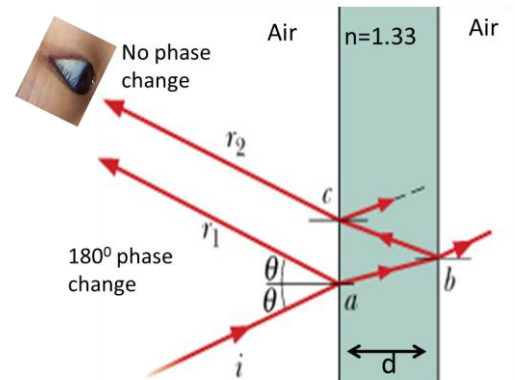

$$d = \frac{(m - \frac{1}{2})\lambda}{2n} = \frac{\lambda}{4n} = \frac{550 \text{ nm}}{4 \times 1.38} = 100 \text{ nm}$$

3- A disabled tanker leaks kerosene ($n=1.20$) into the Persian Gulf, creating a large slick on top of water ($n = 1.33$).

- (a) If you look straight down from aero plane on to the region of slick where thickness is 460nm, for which wavelengths of visible light is the reflection is greatest?
- (b) If you are scuba diving directly under this region of slick, for which wavelengths of visible light is the transmitted intensity is strongest?

Solution:

The reflected light from the film is brightest at the wavelength (λ) for which the reflected rays are in phase with one another. (constructive interference).

(Both Front & back surface reflections have phase change).

The total path difference for maxima:

$$\text{Path difference} = 2d + \lambda_n/2 + \lambda_n/2 = m\lambda_n,$$

Where ($m=1,2,3,\dots$)

$$2d = (m-1) \lambda/n \quad (\lambda_n = \lambda/n)$$

$$\lambda = 2nd / (m-1)$$

Find λ for $d=460 \text{ nm}$, $n=1.2$ & $m=1,2,3,\dots$

- λ for $m=1$ (not possible)
- For $m=2$: $\lambda=1104 \text{ nm}$ (IR region)
- For $m=3$: $\lambda=552 \text{ nm}$ (Green light-visible)
- For $m=4$: $\lambda=368 \text{ nm}$ (UV light)

So, Green light appears in the reflected light

(B) The wavelengths which are minimally reflected are maximally transmitted, and vice versa.

Maximally transmitted wavelengths are the same as finding the

minimally reflected wavelengths.

The total path difference for **minima**:

$$\text{Path difference} = 2d + \lambda_n/2 + \lambda_n/2 = (m+1/2) \lambda_n$$

where ($m=1,2,3,\dots$) substitute: ($\lambda_n = \lambda/n$)

$$\lambda = 2nd / (m+1/2)$$

Find λ for $d=460 \text{ nm}$, $n=1.2$, & $m=1,2,3,\dots$

- λ for $m=1$: $\lambda=2208 \text{ nm}$ (not visible region)
- For $m=2$: $\lambda=736 \text{ nm}$ (IR region)
- For $m=3$: $\lambda=442 \text{ nm}$

(Blue light-visible) (maximum transmitted)

4- If the wavelength of the incident light is $\lambda=572 \text{ nm}$, rays A and B are out of phase by 1.50λ . Find the thickness d of the film.

Solution

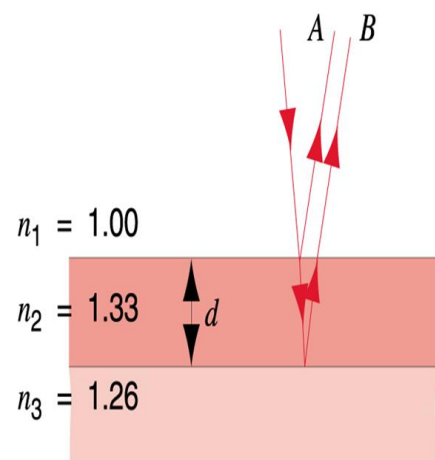

The total path difference for **minima**:

$$\text{Path difference} = 2d + \lambda_n/2 = (m+1/2)\lambda_n$$

$$2d = m\lambda_n$$

m=0 not possible

Take m=1

$$d = \lambda/2n = 215\text{nm}$$

5- A broad source of light (wavelength = 680nm) illuminates normally two glass plates 120 mm long that touch at one end and are separated by a wire 0.048mm in diameter at the other end. How many bright fringes appear over 120 mm distance?

Solution:

Constructive interference occurs when:

$$2d + \frac{\lambda_n}{2} = m\lambda_n$$

$$m = ?$$

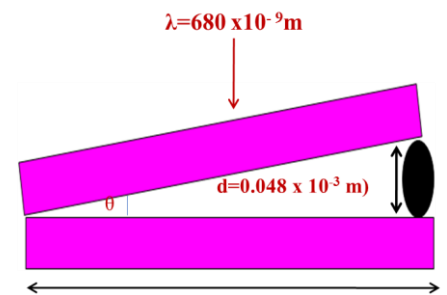

$$m = \frac{2nd}{\lambda} + \frac{1}{2} = \frac{2 \times 1 \times (0.048 \times 10^{-3})}{680 \times 10^{-9}} + \frac{1}{2} = 141.67$$

$$= 141$$

6- A thin film of acetone (n = 1.25) is coating a thick glass plate (n = 1.50). Plane light waves of variable wavelengths are incident normal to the film. When one views the reflected wave, it is noted that complete destructive interference occurs at 600nm and constructive interference at 700nm. Calculate **the thickness** of the acetone film?

Solution:

Constructive interference

$$2d + \lambda_n/2 + \lambda_n/2 = m\lambda_n$$

$$\text{Gives : } 2nd = (m-1)\lambda$$

$$2nd = (m-1)(700\text{nm}) \dots\dots\dots(1)$$

Destructive interference

$$2d + \lambda_n/2 + \lambda_n/2 = (m+1/2)\lambda_n$$

$$2nd = (m-1/2)\lambda$$

$$2nd = (m-1/2)(600\text{nm}) \dots\dots\dots(2)$$

$$\text{Divide (1)/(2): } m=4, d=840 \text{ nm}$$

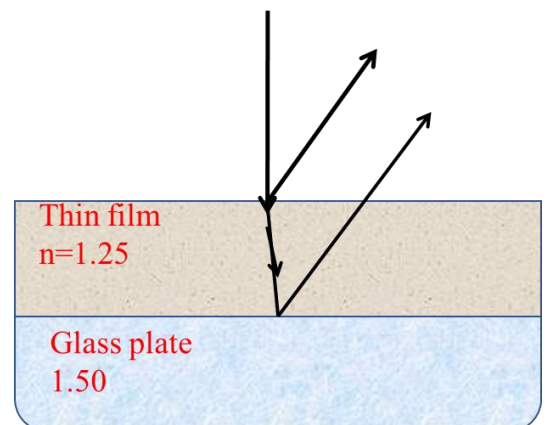

7- We wish to coat a flat slab of glass (n = 1.5) with a transparent material (n=1.25) so that light of wavelength 620nm (in vacuum) incident normally is not reflected. What should be the **minimum** thickness of the coating?

Both the reflected rays r_1 (front surface reflection) and r_2 (back surface reflection) have additional path difference ($\lambda/2$).

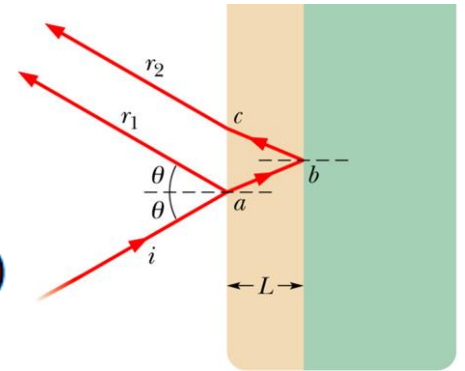

$$2d + \frac{\lambda_n}{2} + \frac{\lambda_n}{2} = (m + \frac{1}{2})\lambda_n \text{ (minima)}$$

$m=1$

$$d = \frac{(m - \frac{1}{2})\lambda}{2n} = \frac{\lambda}{4n} = \frac{620\text{nm}}{4 \times 1.25} = 124\text{nm}$$

8- A thin film in air is 410nm thick and is illuminated by white light normal to its surface. Its index of refraction is 1.50. What wavelength in the visible spectrum will be intensified in the reflected beam?

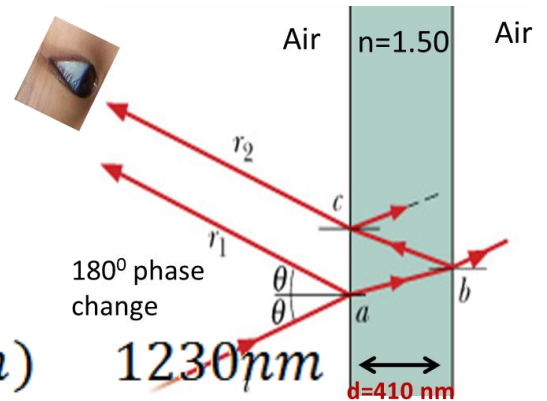

$$2d + \frac{\lambda_n}{2} = m\lambda_n \text{ (maxima)}$$

$$\lambda = \frac{2nd}{(m - \frac{1}{2})} = \frac{(2)(1.5)(410\text{nm})}{(m - \frac{1}{2})} = \frac{1230\text{nm}}{(m - \frac{1}{2})}$$

The result is only in the visible range when

$$m = 3, \text{ so } \lambda = 492 \text{ nm.}$$

9- In costume jewelry, rhinestones (made of glass with $n = 1.50$) are often coated with silicon monoxide ($n = 2.0$) to make them more reflective. How thick should the coating be to achieve strong reflection for 560 nm light incident normally?

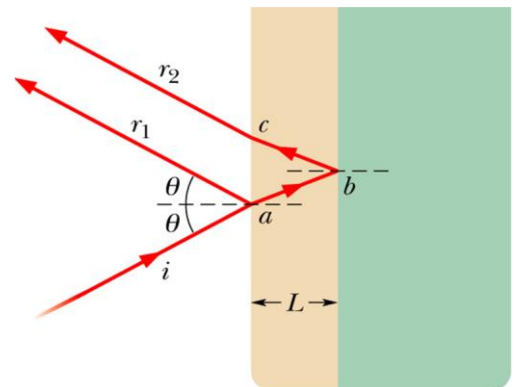

$$2d + \frac{\lambda_n}{2} = m\lambda_n \text{ (maxima)}$$

$$d = \frac{(m - \frac{1}{2})\lambda}{2n} = \frac{\lambda}{4n} = \frac{560\text{nm}}{4 \times 2} = 70\text{nm}$$

10- Light of wavelength 585nm is incident normally on a thin, soapy film (n=1.33) suspended in air. If the film is 0.00121mm thick, determine whether it appears bright or dark when observed from point near the light source.

solution:

m should be an integer.

$$2d + \frac{\lambda_n}{2} = (m + 1/2)\lambda_n \text{ (minima)}$$

$$m = \frac{2nd}{\lambda} = \frac{2(1.33)(1.21 \times 10^{-6} \text{ m})}{(585 \times 10^{-9} \text{ m})} = 5.5$$

So the interference is NOT dark.

$$2d + \frac{\lambda_n}{2} = m\lambda_n \text{ (maxima)}$$

$$m = \frac{2nd}{\lambda} + \frac{1}{2} = \frac{2(1.33)(1.21 \times 10^{-6} \text{ m})}{(585 \times 10^{-9} \text{ m})} = 6.00$$

So the interference is bright.

11- White light reflected at perpendicular incidence from a soap film in air has, in the visible spectrum, an interference maximum at 600nm and a minimum at 450nm with no minimum in between. If n = 1.33 for the film, what is the film thickness?

Solution:

With First source (λ=600nm):

$$2d + \frac{\lambda_n}{2} = m\lambda_n \text{ (maxima)}$$

$$2nd + \frac{600}{2} = 600m$$

$$2nd + 300 = 600m \dots \dots \dots (1)$$

With second source (λ=450nm):

$$2d + \frac{\lambda_n}{2} = (m + \frac{1}{2})\lambda_n \text{ (minima)}$$

$$2nd + 225 = (m + \frac{1}{2})450 \dots \dots \dots (2)$$

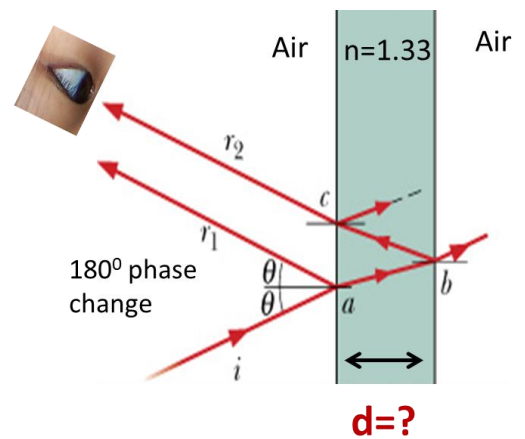
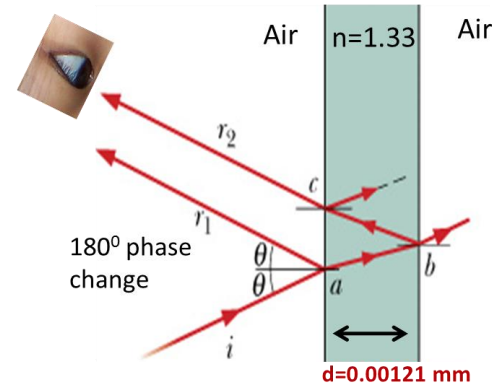

Dividing eqn(1) by(2):

$$We\ get\ m = \frac{600}{2(600 - 450)} = 2$$

Use equation (1) or (2) to solve for d:

From equation (2)

$$d = 2 \times 450 / 2 \times 1.33 = 338\ nm$$

12- Light of wavelength 630nm is incident normally on a thin wedge-shaped film with index of refraction 1.50. There are ten bright and nine dark fringes over the length of the film. By how much does the film thickness changes over the length?

Solution:

Number of bright bands in 'x' mm length. 10 bright & 9 dark bands. Film thickness over the length $d_2 - d_1 = ?$

Constructive interference occurs when:

$$2d + \frac{\lambda_n}{2} = m\lambda_n \rightarrow 2nd + \frac{\lambda_n}{2} = m\lambda_n \rightarrow 2nd = (m - \frac{1}{2})\lambda$$

"Let for the first bright band minimum value of " $m=1$

&the last bright band be $m = 10$

$$Then,\ 2nd_1 = (m_1 - \frac{1}{2})\lambda \dots (1)$$

$$\&2nd_2 = (m_2 - \frac{1}{2})\lambda \dots (2)$$

Eqn(2) – eqn(1) gives

$$(d_2 - d_1) = 9\lambda / 2n = 9(630\ nm) / 2(1.50) = 1.89\ \mu m$$

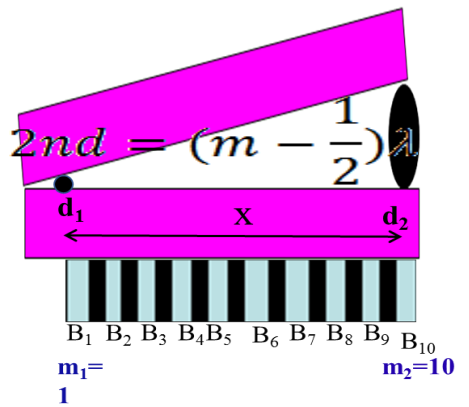

Michelson's interferometer

Purpose

Interferometers are basic optical tools used to precisely measure wavelength, distance, index of refraction of optical beams. It is a device working on the principle of interference of light and is used in precise measurements of length or changes in length.

Working principle

- Light from an extended monochromatic source P falls on a half-silvered mirror M.
- The incident beam is divided into reflected and transmitted beams of equal intensity (Division of amplitude).
- These two beams travel almost in perpendicular directions and will be reflected normally from movable mirror (M_2) and fixed mirror (M_1).
- The two beams finally proceed towards a telescope (T) through which interference pattern of circular fringes will be seen.
- The interference occurs because the two light beams travel different paths between M and M_1 or M_2 .
- Each beam travels its respective path twice. When the beams recombine, their path difference is $2(d_2 - d_1)$.
- The path difference can be changed by moving mirror M_2 . As M_2 is moved, the circular fringes appear to grow or shrink depending on the direction of motion of M_2 .
- New rings appear at the center of the interference pattern and grow outward or larger rings collapse disappear at the center as they shrink.
- Each fringe corresponds to a movement of the mirror M_2 through one-half wavelength. The number of fringes is thus the same as the number of half wavelength.
- If N fringes cross the field of view when mirror M_2 is moved by Δd , then

$$\Delta d = N (\lambda/2)$$

- Δd is measured by a micrometer attached to M_2 . Thus microscopic length measurements can be made by this interferometer.

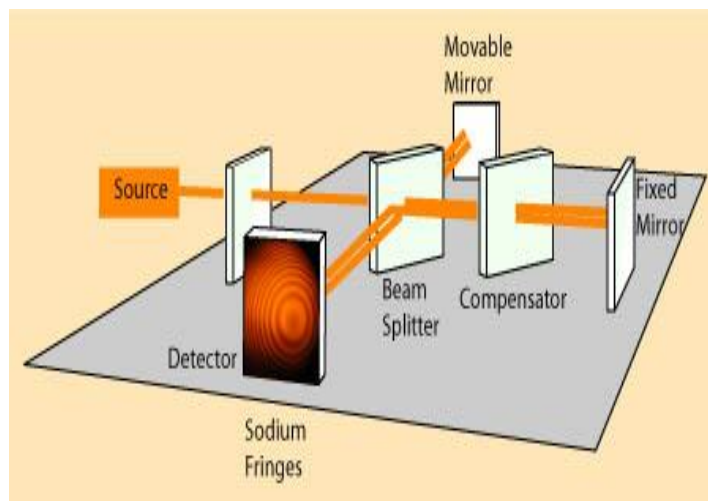

Michelson interferometer equation

$$2(\Delta d) = N\lambda$$

The interferometer is used to measure changes in length by counting the number of interference fringes that pass the field of view as mirror M_2 is moved.

Length measurements made in this way can be accurate if large numbers of fringes are counted.

Applications

1- Determination of wavelength

The fact that whenever the movable mirror moves by

a fringe originates or vanishes at the center is used to determine λ from the equation $2d = N \lambda$, where d is the distance moved and N , the number of fringes originated or vanished.

2- Determination of refractive index (n)

When a thin film (whose refractive index n is to be determined) of thickness ' d ' is introduced on the path of one of the interfering beams, an additional path difference $(n-1)d$ will be introduced.

As a result, there will be shift of fringes. If ' m ' fringes shift, then, $2d(n-1) = m\lambda$ from which ' n ' can be determined.

Examples

- 1- Yellow light (wavelength = 589nm) illuminates a Michelson interferometer. How many bright fringes will be counted as the mirror is moved through 1.0 cm?

Solution:

The number of fringes is the same as the number of half wavelengths in 1.0000 cm.

$$\begin{aligned} N\lambda &= 2d \\ N &= 2d/\lambda = 2(1.0000 \times 10^{-2} \text{ m}) / (589 \times 10^{-9} \text{ m}) \\ &= 33,956 \text{ fringes} \end{aligned}$$

- 2- If mirror M_2 in Michelson's interferometer is moved through 0.233mm, 792 fringes are counted with a light meter. What is the wavelength of the light used?

Solution:

$$\begin{aligned} N\lambda &= 2d \\ \lambda &= 2d/N = 2(0.233 \text{ mm}) / 792 = 588 \text{ nm} \\ &= 588 \text{ nm} \end{aligned}$$

- 3- An airtight chamber 5.0 cm long with glass windows is placed in one arm of a Michelson's interferometer as indicated in Fig 41-28. Light of wavelength $\lambda = 500 \text{ nm}$ is used. The air is slowly evacuated from the chamber using a vacuum pump. While the air is being removed, 60 fringes are observed to pass through the view. From these data find the index of refraction of air at atmospheric pressure.

Solution:

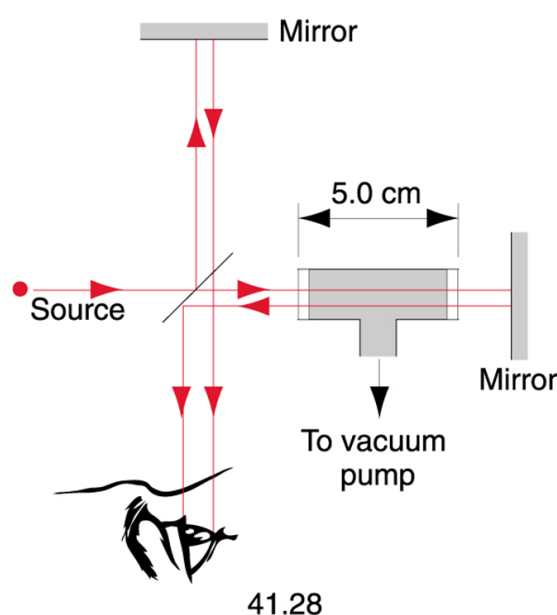
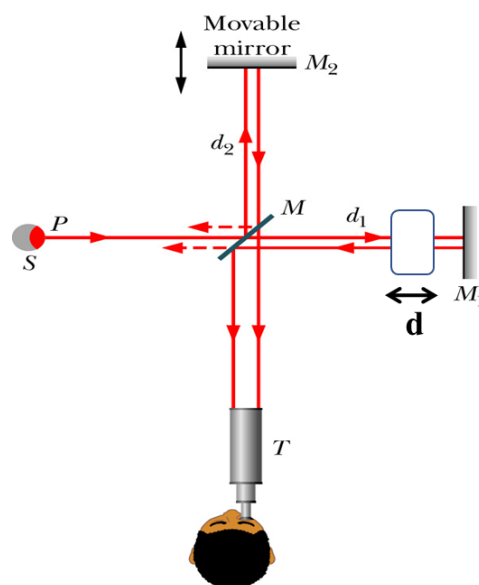

The change in the optical path length is

$$2(nd - d)$$

$$2d(n-1)=m\lambda$$

$$n=m\lambda/2d+1=1.00030$$

- 4- A thin film with $n=1.42$ for light of wavelength 589nm is placed in one arm of a Michelson interferometer. If a shift of 7 fringes occurs, what is the film thickness?

Solution:

$$2d(n-1) = m\lambda$$

$$d = m\lambda / 2(n-1)$$

$$\begin{aligned} d &= 7 \times (589 \times 10^{-9} \text{ m}) / 2(1.41-1) \\ &= 4.9 \times 10^{-6} \text{ m} \end{aligned}$$

Exercises

- 1- What is the necessary condition on the path length difference (and phase difference) between two waves that interfere (A) constructively and (B) destructively ?
- 2- Obtain an expression for the fringe-width in the case of interference of light of wavelength λ , from a double-slit of slit-separation d .
- 3- Explain the term coherence.
- 4- Obtain an expression for the intensity of light in double-slit interference using phasor-diagram.
- 5- Draw a schematic plot of the intensity of light in a double-slit interference against phase-difference (and path-difference).
- 6- Explain the term reflection phase-shift.
- 7- Obtain the equations for thin-film interference.
- 8- Explain the interference-pattern in the case of wedge-shaped thin-films.
- 9- Obtain an expression for the radius of m^{TH} order bright ring in the case of Newton's rings.
- 10- Explain Michelson's interferometer. Explain how microscopic length measurements are made in this.

Chapter 3

Diffraction of Light

Diffraction is the slight bending of light as it passes around the edge of an object. The amount of bending depends on the **relative size of the wavelength of light to the size of the opening**.

- If the opening is **much larger** than the light's wavelength, the bending will be almost **unnoticeable**.
- However, if the two are **closer in size or equal**, the amount of bending is **considerable**, and easily seen with the naked eye.

DIFFRACTION OF WAVES

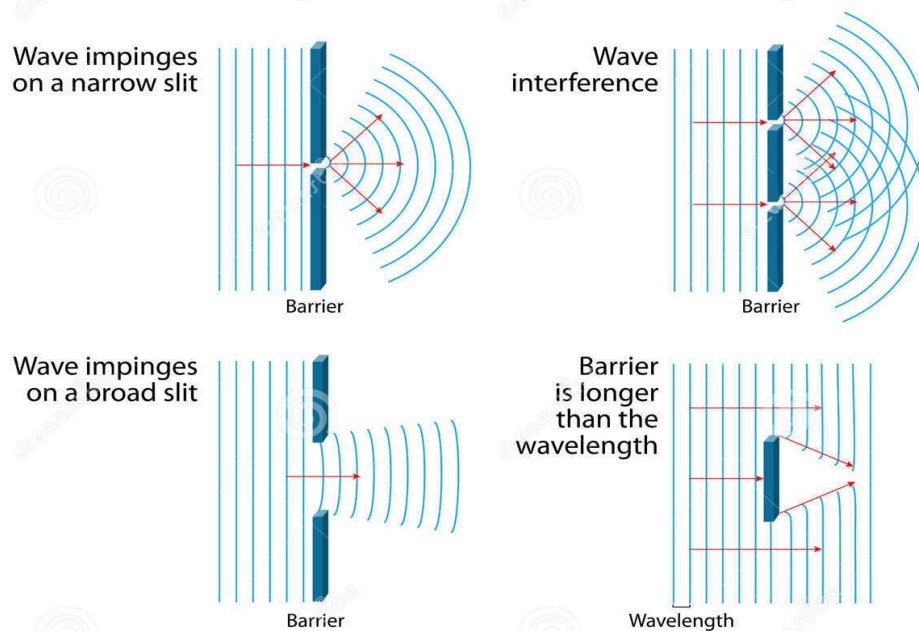

Diffraction pattern

We might expect that the light passing through a small opening would simply result in a broad region of light on a screen, due to the spreading of the light as it passes through the opening.

A diffraction pattern consisting of **light and dark areas** is observed, somewhat similar to the interference patterns discussed earlier.

The pattern consists of a **broad, intense central band (called the central maximum)**, flanked by a series of narrower, **less intense**

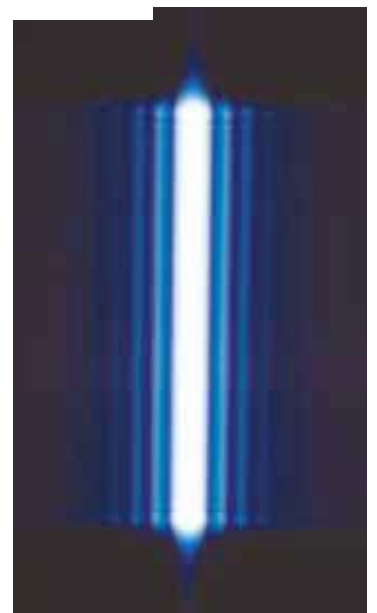

additional bands (called side maxima or secondary maxima) and a series of intervening dark bands (or minima).

Light from a small source pass by the edge of an opaque object and continues on to a screen. A diffraction pattern consisting of bright and dark fringes appears on the screen in the region above the edge of the object.

When more than one slit is present, we must consider **not only diffraction** patterns due to the individual slits but **also the interference patterns** due to the waves coming from different slits.

Notice the curved dashed lines which indicate a decrease in intensity of the interference maxima as θ increases. This decrease is due to a diffraction pattern.

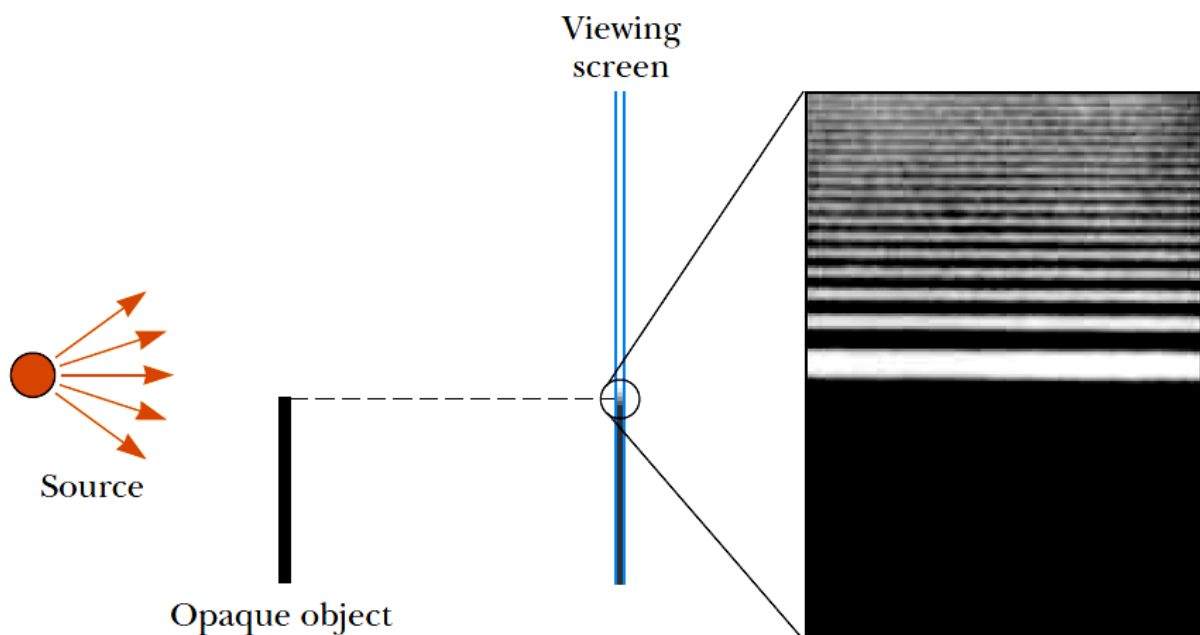

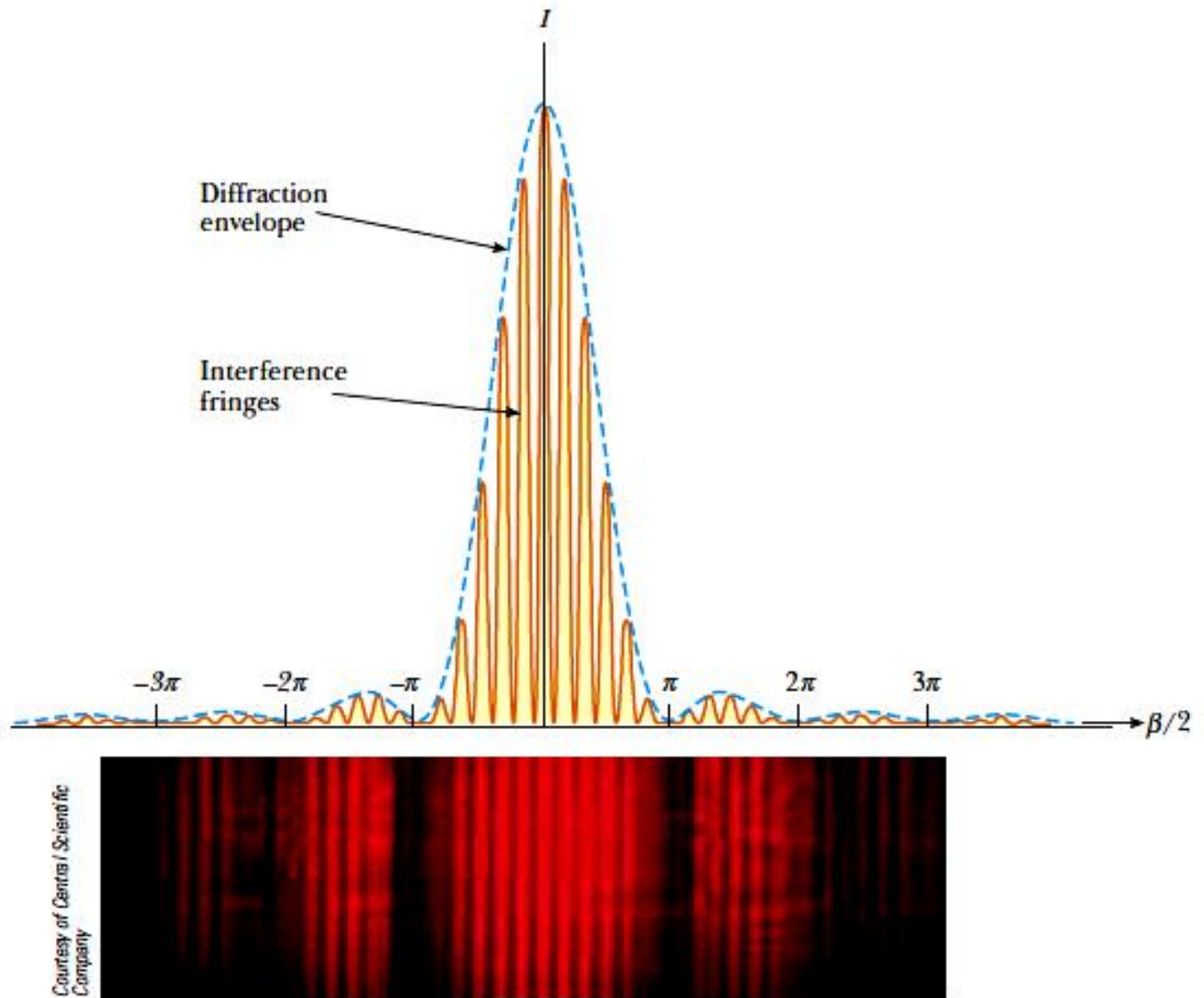

Examples of diffraction

- The closely spaced tracks on a CD or DVD act as a diffraction grating to form the familiar rainbow pattern seen when looking at a disc.
- Circular waves generated by diffraction from the narrow entrance of a flooded coastal quarry
- Diffraction can also be a concern in some technical applications; it sets a fundamental limit to the resolution of a camera, telescope, or microscope.
- In the atmosphere, diffracted light is actually

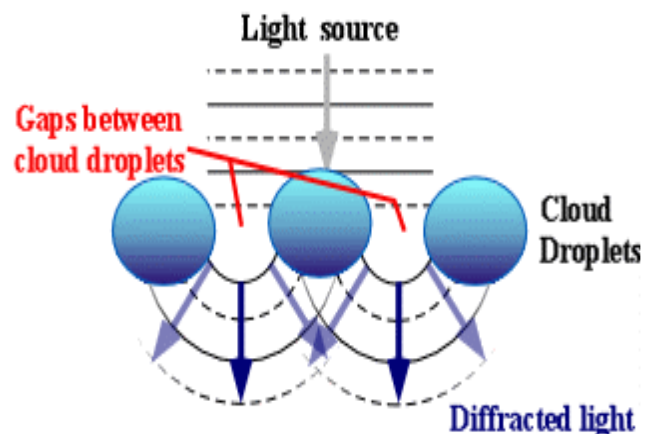

bent around atmospheric particles -- most commonly, the atmospheric particles are tiny water droplets found in clouds.

- Diffracted light can produce **fringes of light, dark or colored bands**.
- An optical effect that results from the diffraction of light is the **silver lining** sometimes found around the edges of clouds or coronas surrounding the sun or moon.

Principle of action

Diffraction arises because of the way in which waves propagate; this is described by the **Huygens–Fresnel principle** and the principle of **superposition of waves**.

- The propagation of a wave can be visualized by considering every particle of the transmitted medium on a wave front as a point source for a secondary spherical wave.
- The wave displacement at any subsequent point is the sum of these secondary waves.
- When waves are added together, their sum is determined by the relative phases as well as the amplitudes of the individual waves so that the summed amplitude of the waves can have any value between zero and the sum of the individual amplitudes.
- Hence, diffraction patterns usually have a series of maxima and minima.

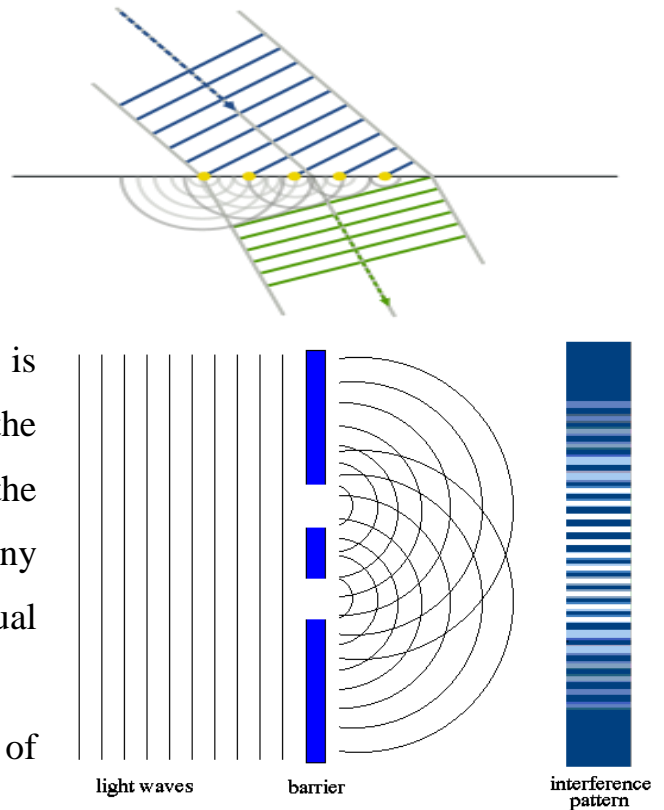

Types of diffraction

Diffraction can usually be characterized by one of two types:

- Fresnel diffraction
- Fraunhofer diffraction

Fresnel diffraction:

diffraction which occurs when both point source and the screen are relatively close to the obstacle.

Fraunhofer diffraction:

diffraction which occurs when both point source and the screen are far enough to the obstacle.

Comparison of Fresnel and Fraunhofer Diffraction

Fraunhofer Diffraction	Fresnel Diffraction
➤ Source and the screen are far away from each other.	➤ Source and screen are not far away from each other.
➤ Incident wave fronts on the diffracting obstacle are plane.	➤ Incident wave fronts are spherical.
➤ Diffraction obstacles give rise to wave fronts which are also plane.	➤ Wave fronts leaving the obstacles are also spherical.
➤ Plane diffracting wave fronts are converged by means of a convex lens to produce diffraction pattern.	➤ Convex lens is not needed to converge the spherical wave fronts.

Diffraction through a Single Slit

Light passing through a single slit form a diffraction pattern somewhat different from those formed by double slits or diffraction gratings

Note that the central maximum is larger than maxima on either side.

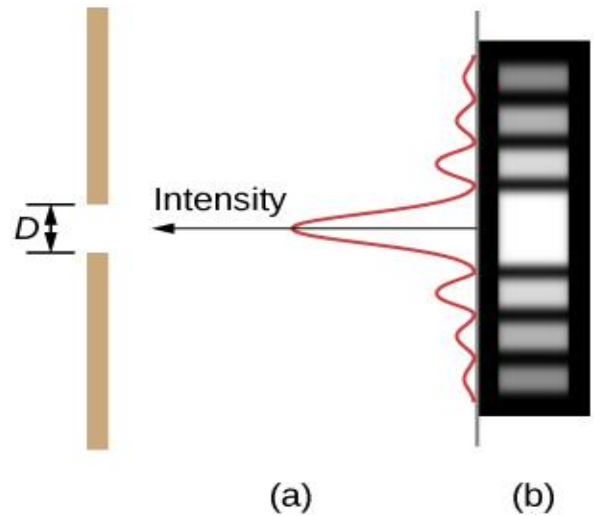

- The intensity decreases rapidly on either side.
- In contrast, a diffraction grating produces evenly spaced lines that dim slowly on either side of the center.
- According to Huygens' principle each portion of the slit acts as a source of waves. Hence, light from one portion of the slit can interfere with light from another portion, and the resultant intensity on the screen depends on the direction θ .
- Consider waves 1 and 3, which originate at the bottom and center of the slit, respectively.
- Wave 1 travels farther than wave 3 by an amount equal to the path difference $(a/2) \sin \theta$, where a is the width of the slit.
- Similarly, the path difference between waves 3 and 5 is $(a/2) \sin \theta$.
- If this path difference is exactly half of a wavelength (corresponding to a phase difference of 180°), the two waves cancel each other and destructive interference results.
- This is true, in fact, for any two waves that originate at points separated by half the slit width because the phase difference between two such points is 180° .
- Therefore, waves from the upper half of the slit interfere *destructively* with waves from the lower half of the slit when

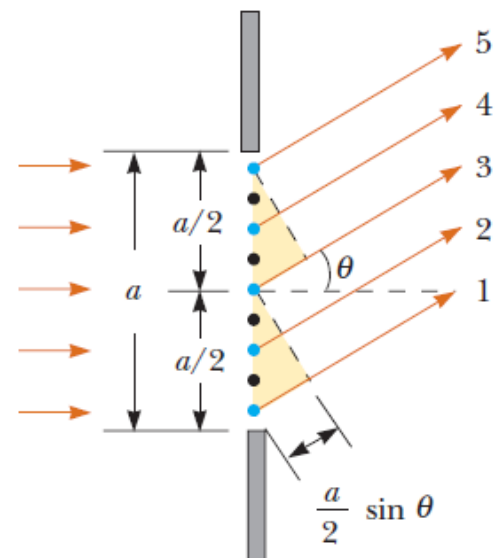

$$\frac{a}{2} \sin \theta = \frac{\lambda}{2} \quad \sin \theta = \frac{\lambda}{a}$$

If we divide the slit into four parts rather than two and use similar reasoning, we find that the screen is also dark when

Continuing in this way, we can divide the slit into six parts and show that darkness occurs on the screen when

$$\sin \theta = \frac{2\lambda}{a}$$

$$\sin \theta = \frac{3\lambda}{a}$$

Therefore, the general condition for **destructive interference** for a single slit of width a is

$$\sin \theta_{\text{dark}} = m \frac{\lambda}{a} \quad m = \pm 1, \pm 2, \pm 3, \dots$$

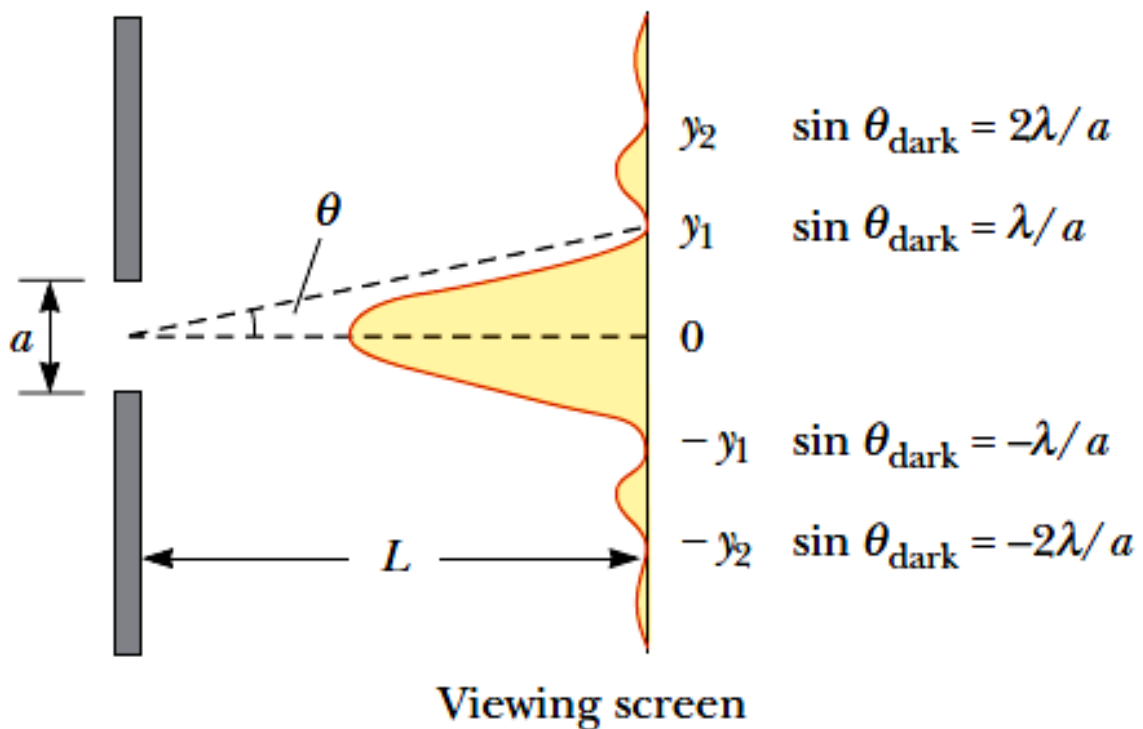

Quiz

In a single-slit diffraction experiment, as the width of the slit is made smaller, does the width of the central maximum of the diffraction pattern

- (a) becomes smaller
- (b) become larger
- (c) remain the same?

Example: Light of wavelength $5.80 \times 10^2 \text{ nm}$ is incident on a slit of width 0.300 mm . The observing screen is placed 2.00 m from the slit. Find the positions of the first dark fringes and the width of the central bright fringe.

Solution:

The first dark fringes that flank the central bright fringe correspond to $m \pm 1$

$$\sin \theta = \pm \frac{\lambda}{a} = \pm \frac{5.80 \times 10^{-7} \text{ m}}{0.300 \times 10^{-3} \text{ m}} = \pm 1.93 \times 10^{-3}$$

$$\tan \theta = \frac{y_1}{L}$$

Because θ is very small, we can use the approximation

$\sin \theta$, $\tan \theta$ and then solve for y_1 :

$$\sin \theta \approx \tan \theta \approx \frac{y_1}{L}$$

$$y_1 \approx L \sin \theta = (2.00 \text{ m})(\pm 1.93 \times 10^{-3}) = \pm 3.86 \times 10^{-3} \text{ m}$$

The distance between the positive and negative first-order maxima, which is the width w of the central maximum:

$$w = +3.86 \times 10^{-3} \text{ m} - (-3.86 \times 10^{-3} \text{ m}) = 7.72 \times 10^{-3} \text{ m}$$

Resolution of Single-Slit and Circular Apertures

The ability of optical systems to distinguish between closely spaced objects is limited because of the wave nature of light.

Two point sources far from a narrow slit each produce a diffraction pattern.

- The angle subtended by the sources at the slit is **large enough** for the diffraction patterns to be distinguishable.
- The angle subtended by the sources is **so small** that their diffraction patterns overlap, and the images are not well resolved.

When the central maximum of one image falls on the first minimum of another image, the images are said to be just resolved.

This limiting condition of resolution is known as Rayleigh's criterion.

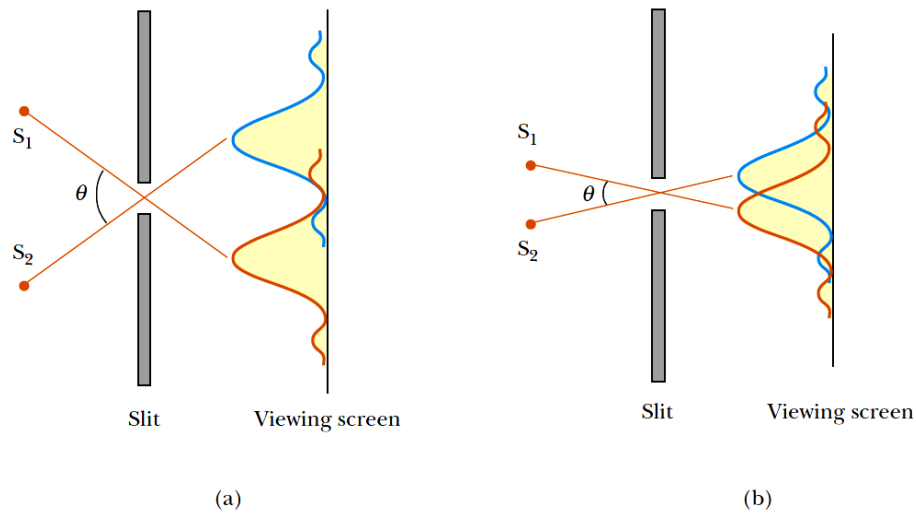

For example: Individual diffraction patterns of two point sources (solid curves) and the resultant patterns (dashed curves) for various angular separations of the sources. In each case, the dashed curve is the sum of the two solid curves.

- (a) The sources are far apart, and the patterns are **well resolved**.
- (b) The sources are closer together such that the angular separation just satisfies **Rayleigh's criterion**, and the patterns are **just resolved**.
- (c) The sources are so close together that the patterns are **not resolved**.

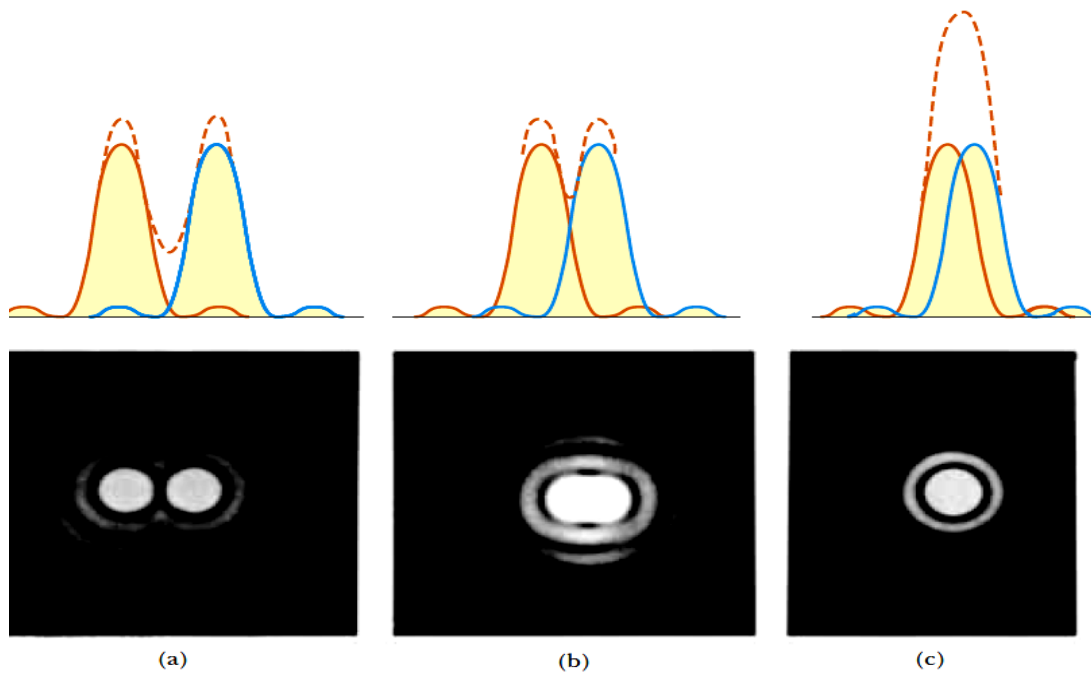

Limiting angle of resolution

The first minimum in a single-slit diffraction pattern occurs at the angle for which

$$\sin \theta = \frac{\lambda}{a}$$

where a is the width of the slit. According to Rayleigh's criterion, this expression gives the smallest angular separation for which the two images are resolved. Because $\lambda \ll a$ in most situations, $\sin \theta$ is small, and we can use the approximation $\sin \theta \approx \theta$.

Therefore, the limiting angle of resolution for a slit of width a is

$$\theta_{\min} = \frac{\lambda}{a}$$

where θ_{\min} is expressed in radians. Hence, the angle subtended by the two sources at the slit must be greater than λ/a if the images are to be resolved.

Limiting angle of resolution for a circular aperture

Many optical systems use circular apertures rather than slits. The diffraction pattern of a circular aperture consists of a central circular bright disk surrounded by progressively fainter bright and dark rings.

Analysis shows that the limiting angle of resolution of the circular aperture is

where D is the diameter of the aperture, the factor 1.22, which arises from a mathematical analysis of diffraction from the circular aperture.

$$\theta_{\min} = 1.22 \frac{\lambda}{D}$$

Examples

- 1- Light of wavelength 589 nm is used to view an object under a microscope. If the aperture of the objective has a diameter of 0.9 cm
- (A) what is the limiting angle of resolution?
- (B) If it were possible to use visible light of any wavelength, what would be the maximum limit of resolution for this microscope?

Solution

- (A) we find that the limiting angle of resolution is

$$\theta_{\min} = 1.22 \left(\frac{589 \times 10^{-9} \text{ m}}{0.900 \times 10^{-2} \text{ m}} \right) = 7.98 \times 10^{-5} \text{ rad}$$

This means that any two points on the object subtending an angle smaller than this at the objective cannot be distinguished in the image.

(B) To obtain the smallest limiting angle, we have to use the shortest wavelength available in the visible spectrum. Violet light (400 nm) gives a limiting angle of resolution of

$$\theta_{\min} = 1.22 \left(\frac{400 \times 10^{-9} \text{ m}}{0.900 \times 10^{-2} \text{ m}} \right) = 5.42 \times 10^{-5} \text{ rad}$$

What If?

Suppose that water ($n = 1.33$) fills the space between the object and the objective. What effect does this have on resolving power when 589-nm light is used?

Solution

Because light travels more slowly in water, we know that the wavelength of the light in water is smaller than that in vacuum.

To find the new value of the limiting angle of resolution, we first calculate the wavelength of the 589-nm light in water using

$$\lambda_{\text{water}} = \frac{\lambda_{\text{air}}}{n_{\text{water}}} = \frac{589 \text{ nm}}{1.33} = 443 \text{ nm}$$

The limiting angle of resolution at this wavelength is

$$\theta_{\min} = 1.22 \left(\frac{443 \times 10^{-9} \text{ m}}{0.900 \times 10^{-2} \text{ m}} \right) = 6.00 \times 10^{-5} \text{ rad}$$

which is indeed smaller than that calculated in part (A).

2- The Keck telescope at Mauna Kea, Hawaii, has an effective diameter of 10 m. What is its limiting angle of resolution for 600-nm light?

$$\theta_{\min} = 1.22 \frac{\lambda}{D} = 1.22 \left(\frac{6.00 \times 10^{-7} \text{ m}}{10 \text{ m}} \right) = 7.3 \times 10^{-8} \text{ rad}$$

Any two stars that subtend an angle greater than or equal to this value are resolved (if atmospheric conditions are ideal).

Quiz

Suppose you are observing a binary star with a telescope and are having difficulty resolving the two stars. You decide to use a colored filter to maximize the resolution. (A filter of a given color transmits only that color of light.)

What color filter should you choose?

- (a) blue
- (b) green
- (c) yellow
- (d) red.

Answer

(a). We would like to reduce the minimum angular separation for two objects below the angle subtended by the two stars in the binary system. We can do that by reducing the wavelength of the light—this in essence makes the aperture larger, relative to the light wavelength, increasing the resolving power. Thus, we should choose a blue filter.

Diffraction grating

Diffraction gratings are used to disperse light; that is to spatially separate light of different wavelengths. They have replaced prisms in most fields of spectral analysis.

When white light enters the grating, the light components are diffracted at angles that are determined by the respective wavelengths(**diffraction**).

- A **transmission grating** can be made by cutting parallel grooves on a glass plate with a precision ruling machine. The spaces between the grooves are transparent to the light and hence act as separate slits.
- A **reflection grating** can be made by cutting parallel grooves on the surface of a reflective material.

The reflection of light from the spaces between the grooves is **specular**, and the reflection from the grooves cut into the material is **diffuse**.

Thus, the spaces between the grooves act as parallel sources of reflected light, like the slits in a transmission grating.

- Current technology can produce gratings that have very small slit spacings. For example, a typical grating ruled with 5000 grooves/cm has a slit spacing $d = (1/5000) \text{ cm} = 2 \times 10^{-4} \text{ cm}$.

The path difference δ between rays from any two adjacent slits is equal to $d \sin \theta$.

If this path difference equals one wavelength or some integral multiple of a wavelength, then waves from all slits are in phase at the screen and a bright fringe is observed.

Therefore, the condition for *maxima* in the interference pattern at the angle θ_{bright} is

$$d \sin \theta_{\text{bright}} = m\lambda \quad m = 0, \pm 1, \pm 2, \pm 3, \dots$$

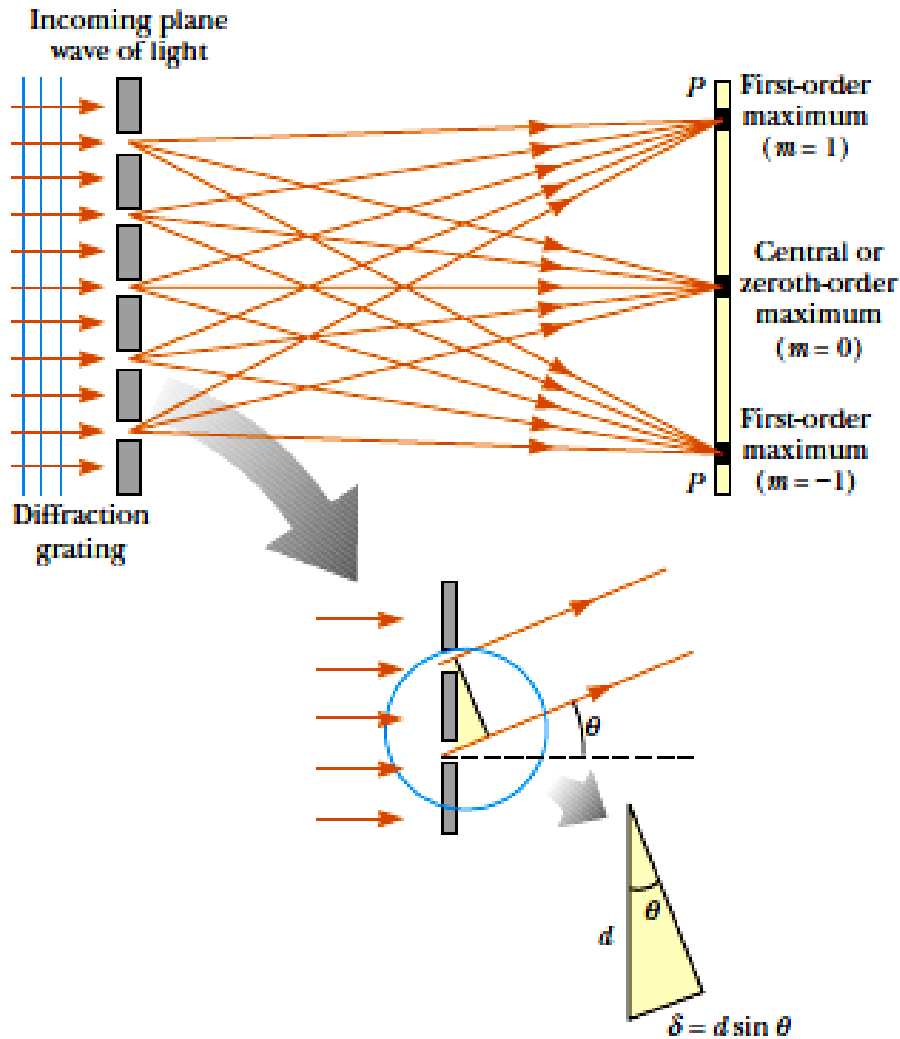

The intensity distribution for a diffraction grating obtained with the use of a monochromatic source.

Note the sharpness of the principal maxima and the broadness of the dark areas. This is in contrast to the broad bright fringe's characteristic of the two-slit interference pattern.

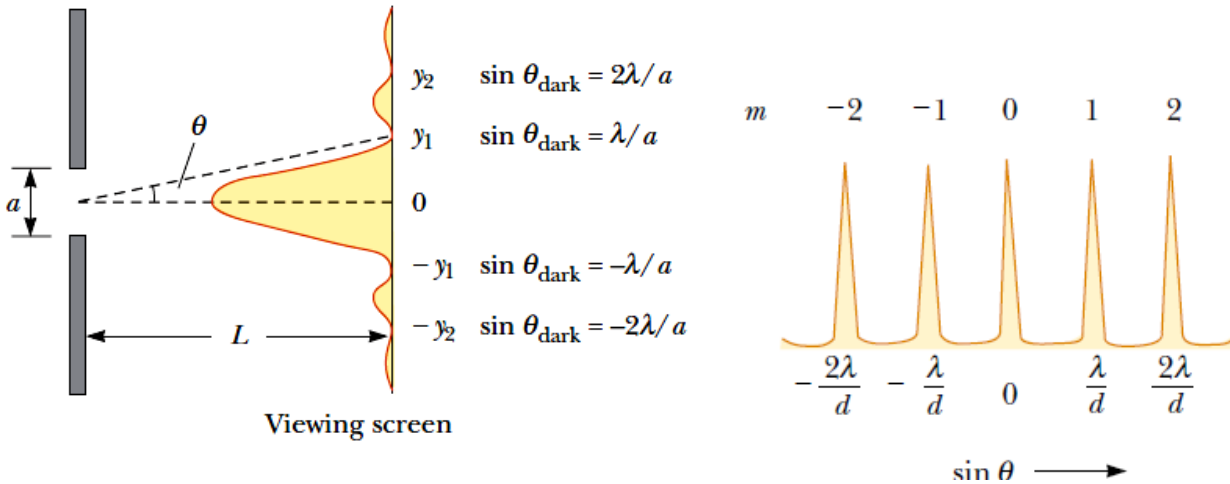

Example: Monochromatic light from a helium–neon laser ($\lambda = 632.8 \text{ nm}$) is incident normally on a diffraction grating containing 6000 grooves per centimeter. Find the angles at which the first- and second-order maxima are observed.

Solution

First, we must calculate the slit separation, which is equal to the inverse of the number of grooves per centimeter:

$$d = \frac{1}{6\,000} \text{ cm} = 1.667 \times 10^{-4} \text{ cm} = 1\,667 \text{ nm}$$

For the first-order maximum ($m=1$), we obtain

$$\sin \theta_1 = \frac{\lambda}{d} = \frac{632.8 \text{ nm}}{1\,667 \text{ nm}} = 0.379\,6$$

$$\theta_1 = 22.31^\circ$$

For the second-order maximum ($m=2$), we find

$$\sin \theta_2 = \frac{2\lambda}{d} = \frac{2(632.8 \text{ nm})}{1\,667 \text{ nm}} = 0.759\,2$$

$$\theta_2 = 49.39^\circ$$

Exercises

- 1- Helium–neon laser light ($\lambda = 632.8 \text{ nm}$) is sent through a 0.300-mm-wide single slit. What is the width of the central maximum on a screen 1.00 m from the slit?
- 2- A screen is placed 50.0 cm from a single slit, which is illuminated with 690-nm light. If the distance between the first and third minima in the diffraction pattern is 3.00 mm, what is the width of the slit?
- 3- A binary star system in the constellation Orion has an angular interstellar separation of $1.00 \times 10^5 \text{ rad}$. If $\lambda = 500 \text{ nm}$, what is the smallest diameter the telescope can have to just resolve the two stars?
- 4- White light is spread out into its spectral components by a diffraction grating. If the grating has 2000 grooves per centimeter, at what angle does red light of wavelength 640 nm appear in first order?
- 5- A monochromatic light beam having a wavelength of $5.0 \times 10^2 \text{ nm}$ illuminates a double slit having a slit separation of $2.0 \times 10^{-5} \text{ m}$. What is the angle of the second-order bright fringe? (a) 0.050 rad (b) 0.025 rad (c) 0.10 rad (d) 0.25 rad (e) 0.010 rad
- 6- A thin layer of oil ($n = 1.25$) is floating on water ($n = 1.33$). What is the minimum nonzero thickness of the oil in the region that strongly reflects green light ($\lambda = 530 \text{ nm}$)? (a) 500 nm (b) 313 nm (c) 404 nm (d) 212 nm (e) 285 nm
- 6- A Fraunhofer diffraction pattern is produced on a screen located 1.0 m from a single slit. If a light source of wavelength $5.0 \times 10^{-7} \text{ m}$ is used and the distance from the center of the central bright fringe to the first dark fringe is $5.0 \times 10^{-3} \text{ m}$, what is the slit width? (a) 0.010 mm (b) 0.10 mm (c) 0.200 mm (d) 1.0 mm (e) 0.005 mm

The phenomenon in which waves of light or other radiation are restricted in direction of vibration.

Light is an electromagnetic wave, and the electric field of this wave oscillates perpendicularly to the direction of propagation. If the direction of the electric field of light is well defined, it is called polarized light.

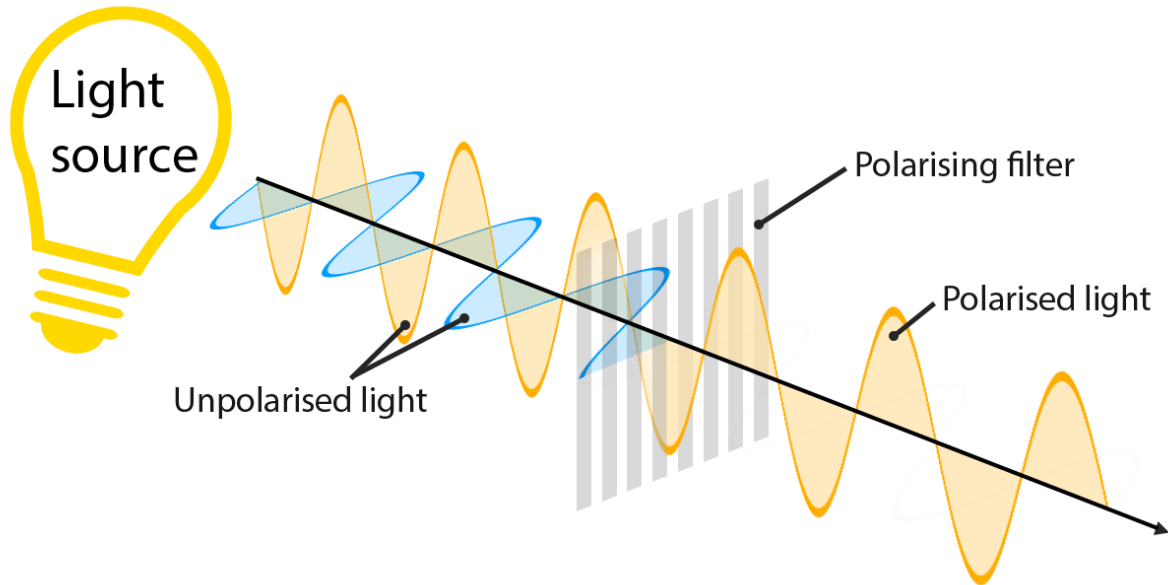

Quiz

Polarization of light establishes that light has

- A. Wave nature
- B. Particles nature
- C. Transverse wave nature
- D. Longitudinal nature

Depending on how the electric field is oriented, we classify polarized light into three types of polarizations:

Linear polarization: the electric field of light is confined to a single plane along the direction of propagation.

Circular polarization: the electric field of light consists of two linear components that are

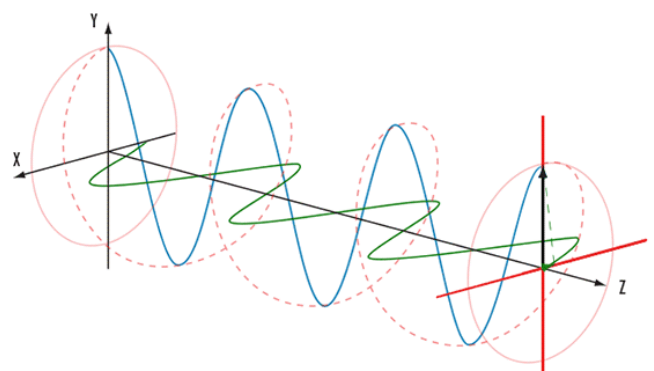
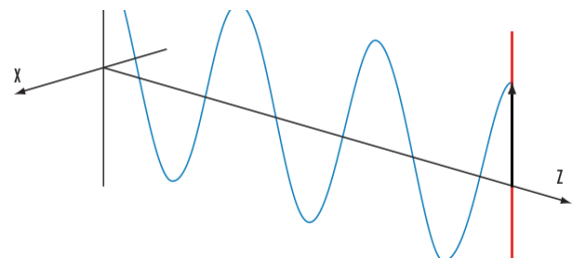
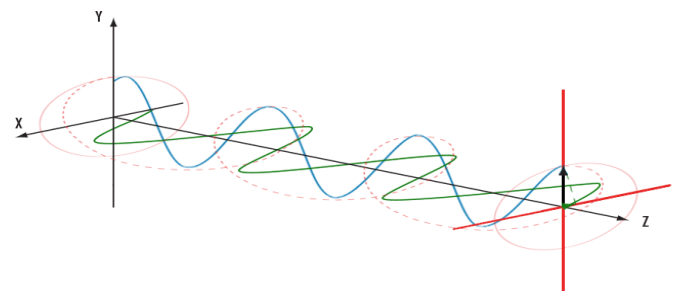

perpendicular to each other, equal in amplitude, but have a phase difference of $\pi/2$. The resulting electric field rotates in a circle around the direction of propagation.

Elliptical polarization: the electric field of light describes an ellipse. This results from the combination of two linear components with differing amplitudes and/or a phase difference that is not $\pi/2$. This is the most general description of polarized light, and circular and linear polarized light can be viewed as special cases of elliptically polarized light.

Techniques of polarization

1- Polarization by Selective Absorption

The most common technique for polarizing light is to use a material that transmits waves having electric field vectors that vibrate in a plane parallel to a certain direction and absorbs those waves with electric field vectors vibrating in directions perpendicular to that direction.

In 1932 E. H. Land discovered a material, which he called **Polaroid**, that polarizes light through selective absorption by oriented molecules.

This material is fabricated in thin sheets of **long-chain hydrocarbons**, which are stretched during manufacture so that the molecules align. After a sheet is dipped into a solution containing iodine, the molecules become good electrical conductors. Conduction takes place primarily along the hydrocarbon chains, however, because the valence electrons of the molecules can move easily only along those chains.

Relationship Between Long-Chain Molecule Orientation and the Orientation of the Polarization Axis

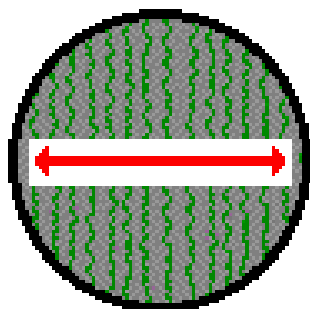

When molecules in the filter are aligned vertically, the polarization axis is horizontal.

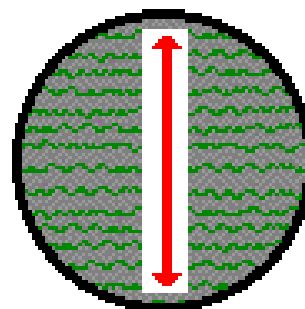

When molecules in the filter are aligned horizontally, the polarization axis is vertical.

As a result, the molecules readily *absorb* light having an electric field vector parallel to their lengths and *transmit* light with an electric field vector perpendicular to their lengths.

It's common to refer to the direction perpendicular to the molecular chains as the transmission axis.

In an ideal polarizer all light with E_S parallel to the transmission axis is transmitted and all light with E_S perpendicular to the transmission axis is absorbed.

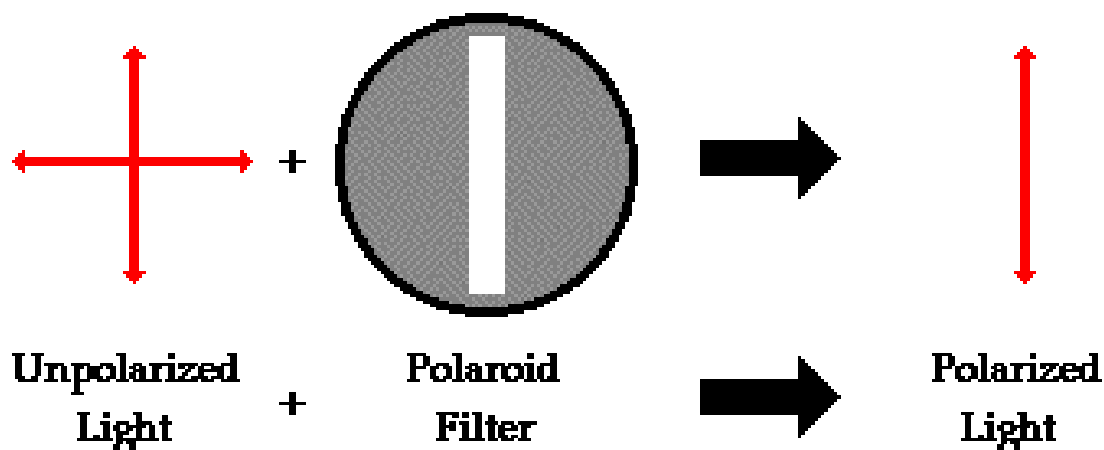

The intensity of light transmitted through two polarizers depends on the relative orientations of their transmission axes.

- The transmitted light has **maximum** intensity when the transmission axes are *aligned* with each other.
- The transmitted light intensity **diminishes** when the transmission axes are at an angle of 45° with each other.
- The transmitted light intensity is a **minimum** when the transmission axes are at *right angles* to each other.



(a)

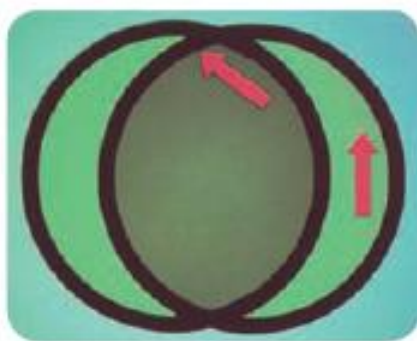

(b)

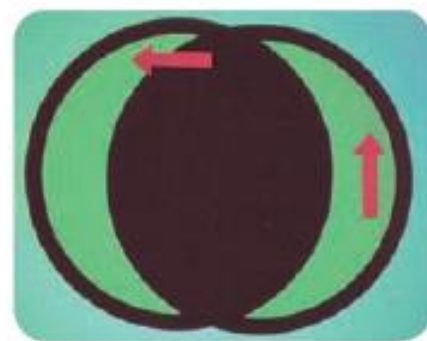

(c)

Quiz

When light was observed through a polarizer, the light intensity was observed to remain constant on rotating the polarizer. The light can be:

- Plane polarized

- B. Unpolarized
- C. Partially polarized
- D. any of the above

Malus' Law

The intensity of polarized light that passes through a polarizer is proportional to the square of the cosine of the angle between the electric field of the polarized light and the angle of the polarizer

Applies to any two polarizing materials having transmission axes at an angle of θ to each other.

$$I = I_0 \cos^2 \theta$$

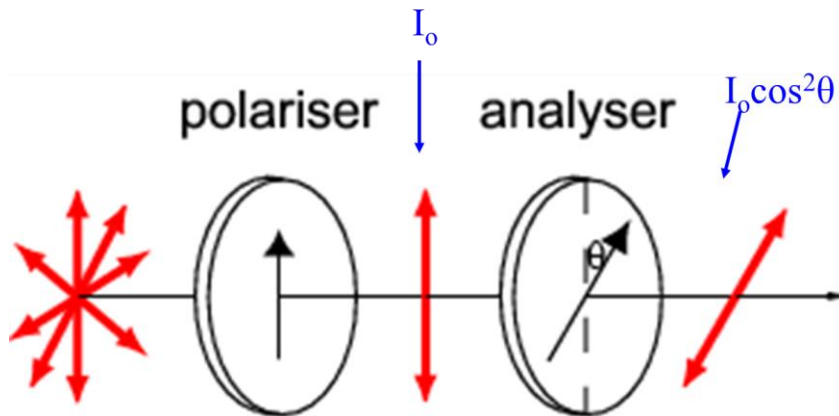

Examples:

- 1- Unpolarized light is incident upon three polarizers. The first polarizer has a vertical transmission axis, the second has a transmission axis rotated 30.0° with respect to the first, and the third has a transmission axis rotated 75.0° relative to the first. If the initial light intensity of the beam is I_0 , calculate the light intensity after the beam passes through
- (a) the second polarizer
 - (b) the third polarizer.

Solution

- (a) Calculate the intensity of the beam after it passes through the second polarizer. The incident intensity is $I_0/2$. Apply Malus' law to the second polarizer:

$$I_2 = I_0 \cos^2 \theta = \frac{I_b}{2} \cos^2 (30.0^\circ) = \frac{I_b}{2} \left(\frac{\sqrt{3}}{2} \right)^2 = \frac{3}{8} I_b$$

(b) Calculate the intensity of the beam after it passes through the third polarizer. The incident intensity is now $3I_b/8$.

- Apply Malus's law to the third polarizer.
- Notice that the angle was not 75.0° , but $75.0^\circ - 30.0^\circ = 45.0^\circ$.
- The angle is always with respect to the previous polarizer's transmission axis because the polarizing material physically determines what direction the transmitted electric fields can have.

$$I_3 = I_2 \cos^2 \theta = \frac{3}{8} I_b \cos^2 (45.0^\circ) = \frac{3}{8} I_b \left(\frac{\sqrt{2}}{2} \right)^2 = \frac{3}{16} I_b$$

2- Unpolarized light is incident on a pair of polarizers as shown in the figure.

(A) Determine the angle θ required—between the transmission axes of polarizers 1 and 2—that will reduce the intensity of light I_0 incident on polarizer 2 by 50%.

(B) For this same reduction, determine by how much the field E_0 incident on polarizer 2.

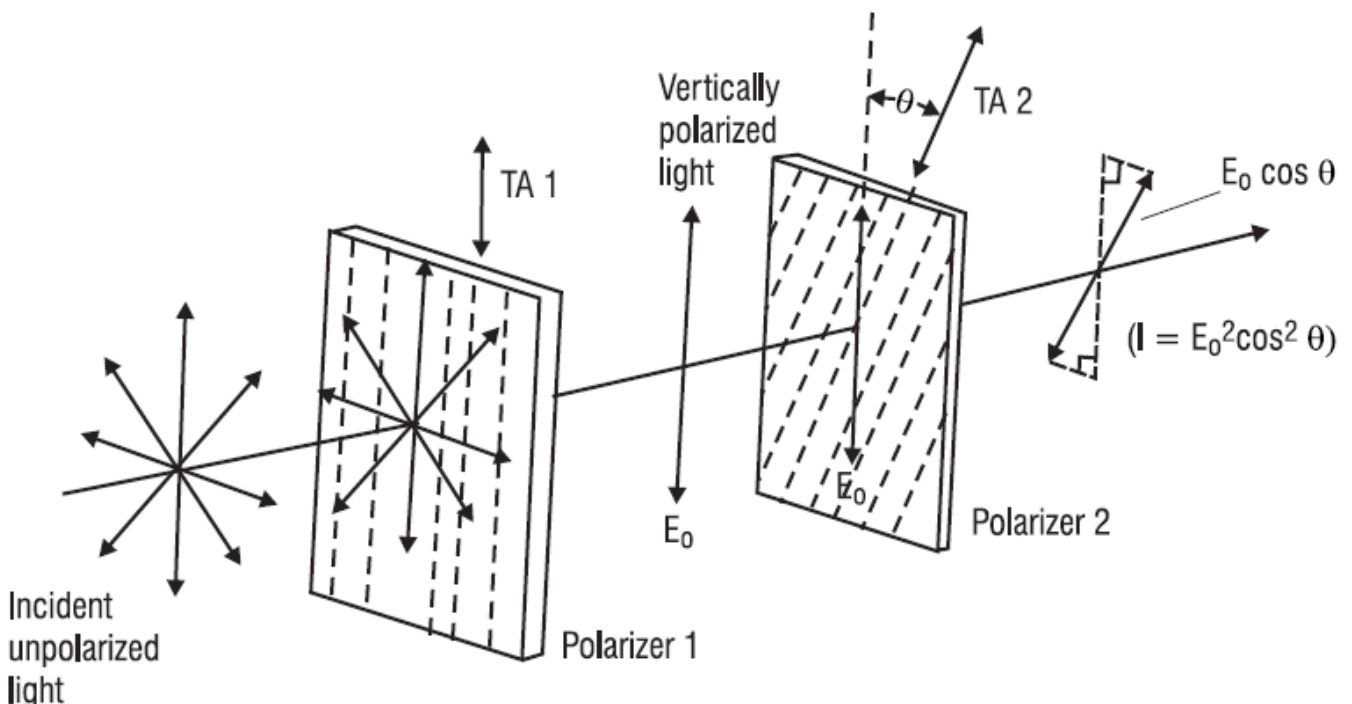

Solution:

A. Based on the statement of the problem, we see that $I = 0.5 I_0$. By applying the *law of Malus*, we have:

$$I = I_0 \cos^2 \theta$$

$$0.5 I_0 = I_0 \cos^2 \theta$$

$$\cos \theta = \sqrt{0.5} = 0.707$$

$$\therefore \theta = 45^\circ$$

So the two TAs should be at an angle of 45° with each other.

B. Knowing that the E-field passed by polarizer 2 is equal to $E_0 \cos \theta$, we have

$$E_2 = E_0 \cos \theta$$

$$E_2 = E_0 \cos 45^\circ$$

$$E_2 = 0.707 E_0 \cong 71\% E_0$$

Thus, the E-field incident on polarizer 2 has been reduced by about 29% after passing through polarizer 2.

2- Polarization by Reflection

When an unpolarized light beam is reflected from a surface, the reflected light is completely polarized, partially polarized, or unpolarized, depending on the angle of incidence.

- If the angle of incidence is either 0° or 90° , the reflected beam is unpolarized.
- For angles of incidence between 0° and 90° , however, the reflected light is polarized to some extent.
- For one particular angle of incidence the reflected beam is completely polarized.

Suppose that an unpolarized light beam is incident on a surface, as shown in the figure.

Each individual electric field vector can be resolved into two components: one parallel to the surface and the other perpendicular both to the first component and to the direction of propagation.

Thus, the polarization of the entire beam can be described by two electric field components in these directions.

It is found that the parallel component reflects more strongly than the perpendicular component, and this results in a partially polarized reflected beam.

Furthermore, the refracted beam is also partially polarized.

Now suppose that the angle of incidence θ_1 is varied until the angle between the reflected and refracted beams is 90°

At this particular angle of incidence, **the reflected beam is completely polarized** (with its electric field vector parallel to the surface), and the refracted beam is still **only partially polarized**.

The angle of incidence at which this polarization occurs is called the **polarizing angle θ_p** .

We can obtain an expression relating the polarizing angle to the index of refraction of the reflecting substance by using figure (b).

From this figure, we see that $\theta_p + 90^\circ + \theta_2 = 180^\circ$; thus, $\theta_2 = 90^\circ - \theta_p$.

Using Snell's law of refraction and taking $n_1 = 1.00$ for air and $n_1 = n$ we have

$$n = \frac{\sin \theta_1}{\sin \theta_2} = \frac{\sin \theta_p}{\sin \theta_2}$$

Because $\sin \theta_2 = \sin(90^\circ - \theta_p) = \cos \theta_p$, we can write this expression for n as $n = \sin \theta_p / \cos \theta_p$, which means

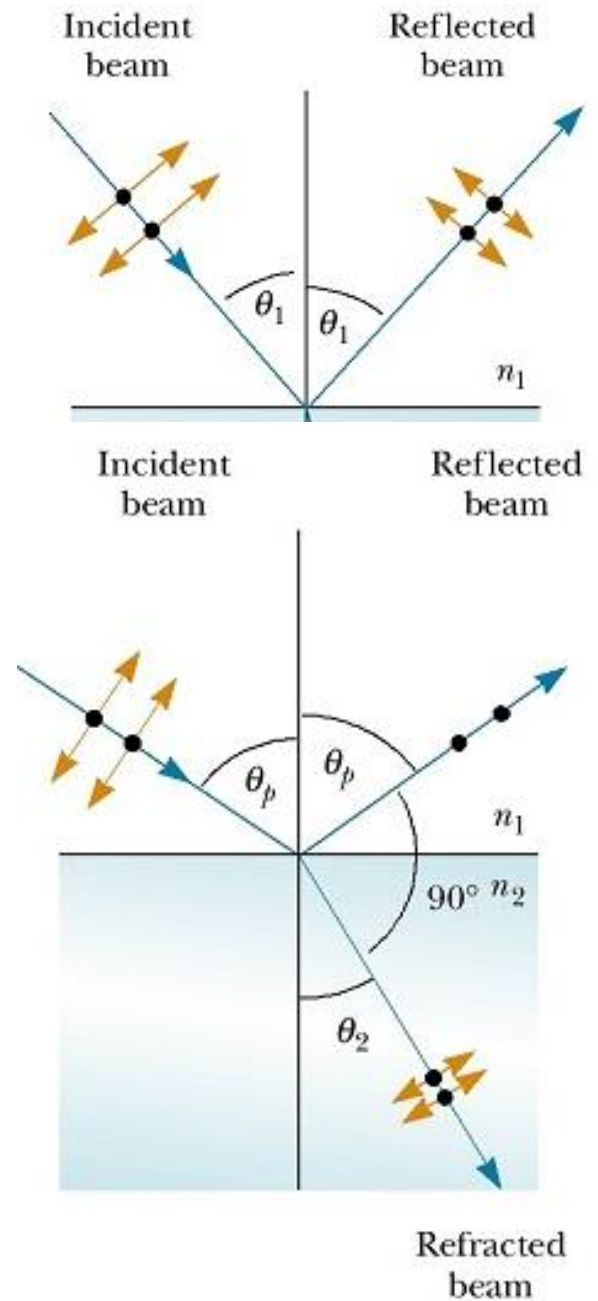

$$n = \tan \theta_p$$

This expression is called **Brewster's law**, and the polarizing angle θ_p is sometimes called **Brewster's angle**

Because n varies with wavelength for a given substance, Brewster's angle is also a function of wavelength.

Examples of polarization by reflection

Polarization by reflection is a common phenomenon we can observe it in our life for example:

- Sunlight reflected from water, glass, and snow is partially polarized. If the surface is horizontal, the electric field vector of the reflected light has a strong horizontal component.
- Sunglasses made of polarizing material reduce the glow of reflected light.
- The transmission axes of the lenses are oriented vertically so that they absorb the strong horizontal component of the reflected light.
- If you rotate sunglasses 90° , they will not be as effective at blocking the glow from shiny horizontal surfaces.

Quiz

- 1- Brewster's Angle occurs when:
 - A. Reflected light is completely plane polarized.
 - B. Reflected light is partially polarized.
 - C. No light is reflected.
 - D. Angle between incident and reflected light is 90 degrees.
- 2- If X is the intensity of unpolarized incident light on a polarizer, what is the intensity of the ray transmitted by the polarizer?
 - A. $X/2$
 - B. $X \cos ((\text{angle}))$

- C. X
- D. $X/\sqrt{2}$

3- If light is made incident on any transparent medium at the polarizing angle, the reflected light is

- A. Unpolarized
- B. Plane polarized
- C. Partially polarized
- D. none of the above

If light is made incident on any transparent medium at the polarizing angle, the angle between the reflected ray and the refracted ray is

- A. 45 degree
- B. 90 degree
- C. 30 degree
- D. 60 degree

3- Polarization by double refraction

Solids can be classified on the basis of internal structure. Those in which the atoms are arranged in a specific order are called **crystalline**; the NaCl structure of figure is just one example of a crystalline solid. Those solids in which the atoms are distributed randomly are called **amorphous**.

When light travels through an amorphous material, such as glass, it travels with the same speed in all directions.

That is, glass has a single index of refraction.

In certain crystalline materials, however, such as **calcite** and **quartz**, the speed of light is not the same in all directions. Such materials are characterized by two indices of refraction. Hence, they are often referred to as double-refracting or birefringent materials.

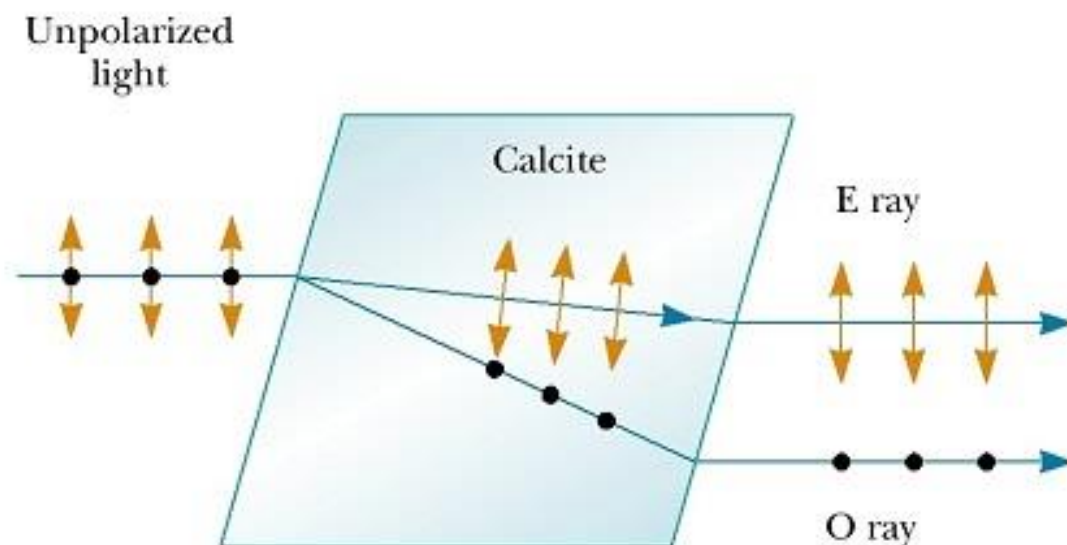

Upon entering a calcite crystal, unpolarized light splits into two plane polarized rays that travel with different velocities, corresponding to two angles of refraction.

One ray, called **the ordinary (O) ray**, is characterized by an index of refraction n_o that is the same in all directions.

This means that if one could place a point source of light inside the crystal the ordinary waves would spread out from the source as **spheres**.

The second plane-polarized ray, called the **extraordinary (E) ray**, travels with different speeds in different directions and

hence is characterized by an index of refraction n_E that varies with the direction of propagation.

The point source sends out an extraordinary wave having wave fronts that are **elliptical** in cross-section.

Note that there is one direction, called the **optic axis**, along which the ordinary and extraordinary rays have the same speed, corresponding to the direction for which $n_o = n_E$.

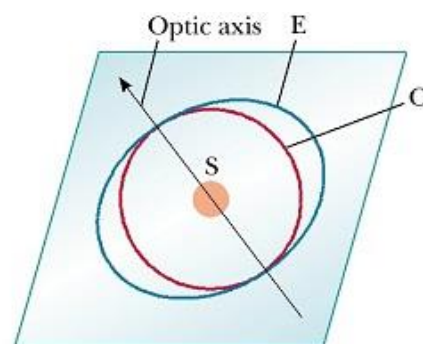

4- Polarization by scattering

When light is incident on any material, the electrons in the material can absorb and reradiate part of the light. Such absorption and reradiation of light by electrons in the gas molecules that make up air is what causes sunlight reaching an observer on the Earth to be partially polarized.

You can observe this effect—called **scattering**—by looking directly up at the sky through a pair of sunglasses whose lenses are made of polarizing material.

Less light passes through at certain orientations of the lenses than at others.

Some phenomena involving the scattering of light in the atmosphere can be understood as follows.

- When light of various wavelengths λ is incident on gas molecules of diameter d , where $d \ll \lambda$, the relative intensity of the scattered light varies as $1/\lambda^4$.

Hence, short wavelengths (blue light) are scattered more efficiently than long wavelengths (red light). Therefore, **when sunlight is scattered by gas molecules in the air, the short-wavelength radiation (blue) is scattered more intensely than the long-wavelength radiation (red).**

- When you look up into the sky in a direction that is not toward the Sun, you see the scattered light, which is predominantly blue; hence, **you see a blue sky.**
- If you look toward the west at sunset (or toward the east at sunrise), you are looking in a direction toward the Sun and are seeing light that has passed through a large distance of air.
- Most of the blue light has been scattered by the air between you and the Sun.
- The light that survives this trip through the air to you has had much of its blue component scattered and is thus heavily weighted toward the red end of the spectrum; as a result, **you see the red and orange colors of sunset.**

Optical activity

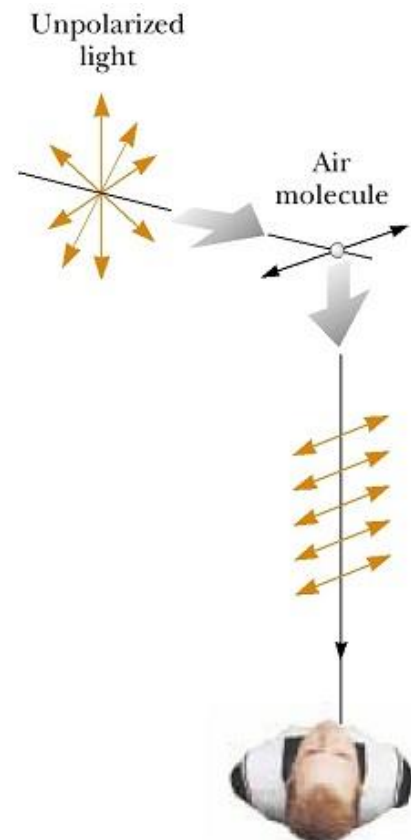

A material is said to be optically active if it rotates the plane of polarization of any light transmitted through the material.

The angle through which the light is rotated by a specific material depends on the **length** of the path through the material and on **concentration** of the material is in solution.

- Sugar solution is optically active.
- The amount of rotation of the plane of polarization depends on the concentration of the solution.
- Molecular asymmetry determines whether a material is optically active.
- For example, some proteins are optically active because of their spiral shape.

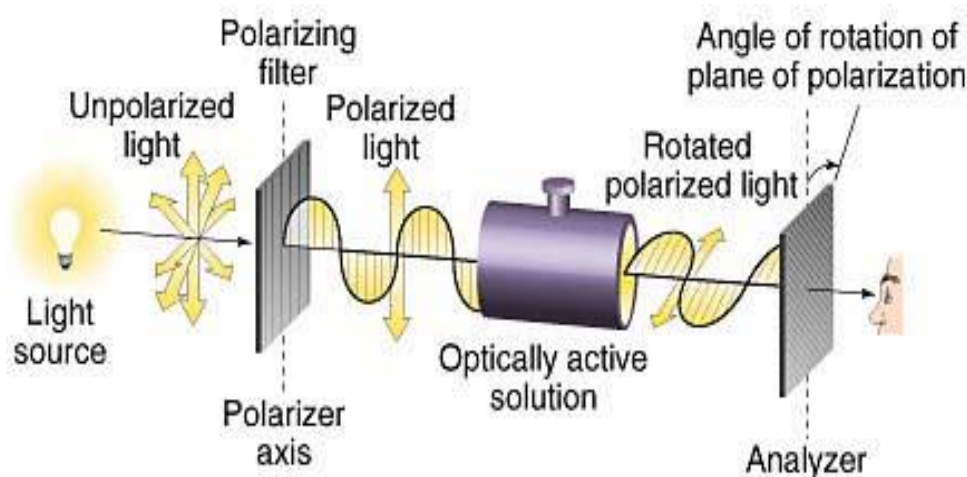
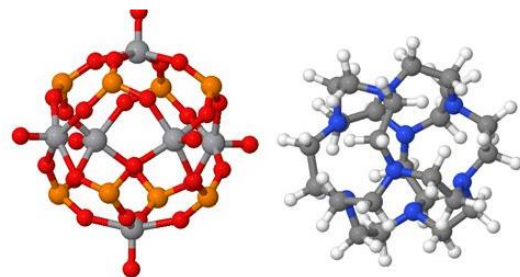

Quiz

An optically active substance...

- A. Polarizes light in vertical plane
- B. Polarizes light in horizontal plane
- C. Rotates plane of polarization
- D. Reduces the degree of polarization

Other materials, such as **glass** and **plastic**, become **optically active when stressed**.

Suppose that an unstressed piece of plastic is placed between a polarizer and an analyzer so that light passes from polarizer to plastic to analyzer. The unstressed plastic has no effect on the light passing through it.

If the plastic is stressed, however, the regions of greatest stress rotate the polarized light through the largest angles. Hence, a series of bright and dark bands is observed in the transmitted light, with the bright bands corresponding to regions of greatest stress.



Summary

- Unpolarized light can be polarized by selective absorption, reflection, or scattering. A material can polarize light if it transmits waves having electric field vectors that vibrate in a plane parallel to a certain direction and absorbs waves with electric field vectors vibrating in directions perpendicular to that direction.
- When unpolarized light passes through a polarizing sheet, its intensity is reduced by half and the light becomes polarized.
- When this light passes through a second polarizing sheet with transmission axis at an angle of θ with respect to the transmission axis of the first sheet, the transmitted intensity is given by
- $I = I_0 \cos^2 \theta$
- where I_0 is the intensity of the light after passing through the first polarizing sheet.
- light reflected from an amorphous material, such as glass, is partially polarized.
- Reflected light is completely polarized, with its electric field parallel to the surface, when the angle of incidence produces a 90° angle between the reflected and refracted beams.

- This angle of incidence, called the **polarizing angle** θ_p , satisfies **Brewster's law**, given by

$$n = \tan \theta_p$$

- where n is the index of refraction of the reflecting medium.

Exercise

- Two polarizers are rotated so that the second polarizer has a transmission axis of 40.0° with respect to the first polarizer and the third polarizer has an angle of 90.0° with respect to the first. If I_b is the intensity of the original unpolarized light, what is the intensity of the beam after it passes through (a) the second polarizer and (b) the third polarizer? (c) What is the final transmitted intensity if the second polarizer is removed?
- If plane-polarized light is sent through two polarizers, the first polarizer at 45° to the original plane of polarization and the second polarizer at 90° to the original plane of polarization, what fraction of the original polarized intensity gets through the last polarizer?
- Unpolarized light passes through two Polaroid sheets. The transmission axis of the analyzer makes an angle of 35.0° with the axis of the polarizer. (a) What fraction of the original unpolarized light is transmitted through the analyzer? (b) What fraction of the original light is absorbed by the analyzer?

Chapter 5

Laser

Introduction

The word 'laser' is an acronym for **Light Amplification by the Stimulated Emission of Radiation**. A laser was first demonstrated in 1960 by Theodore H Maiman working at the Hughes Corporation, although the term 'laser' was first coined by Gordon Gould of Columbia University.

To understand how laser action occurs, one must first consider the atomic nature of matter. An atom consists of a central nucleus surrounded by a cloud of electrons. Quantum theory explains that the electrons in atoms exist in discrete energy states and at thermal equilibrium they are maintained in the so-called 'ground state'. The energy state of an atom can be altered by the emission or absorption of a photon of electromagnetic radiation (light). The electron cloud in atoms which have absorbed light is referred to as existing in an 'excited' or 'higher level' energy state.

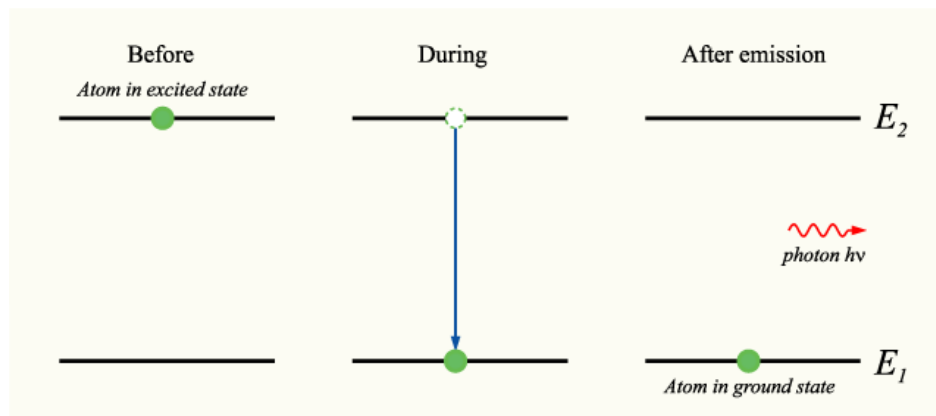

In ordinary light sources such as a filament bulb, electrical energy passing through the tungsten ribbon raises the electrons in the metal atoms into excited energy states. The electrons return to their ground state spontaneously and in so doing release packets, or quanta, of optical energy called photons. Atoms in ordinary light sources radiate photons independently of each other and no phase relationship exists between them. In other words, light generated by spontaneous emission is incoherent. This lack of coherence is one important characteristic that distinguishes ordinary light sources from lasers.

Light absorption and emission

Einstein was the first scientist to propose that an excited atom can return to its ground state in either of two processes, which he referred to as 'spontaneous' and 'stimulated' emission.

Stimulated Absorption

Energy is absorbed by an atom; the electrons are excited into vacant energy shells.

Absorption of radiation or light

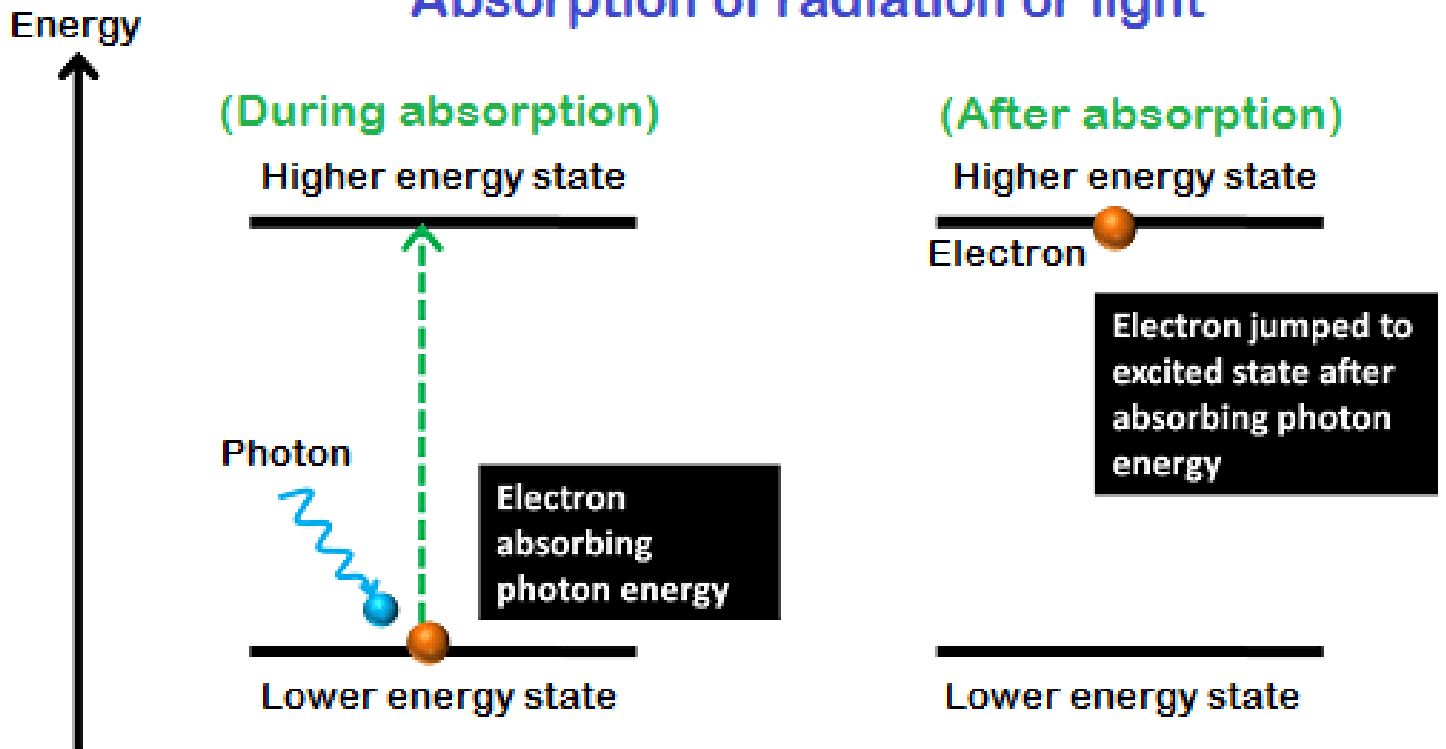

Spontaneous Emission

The atom decays from level 2 to level 1 through the emission of a photon with the energy $h\nu$. It is a completely random process.

Spontaneous emission

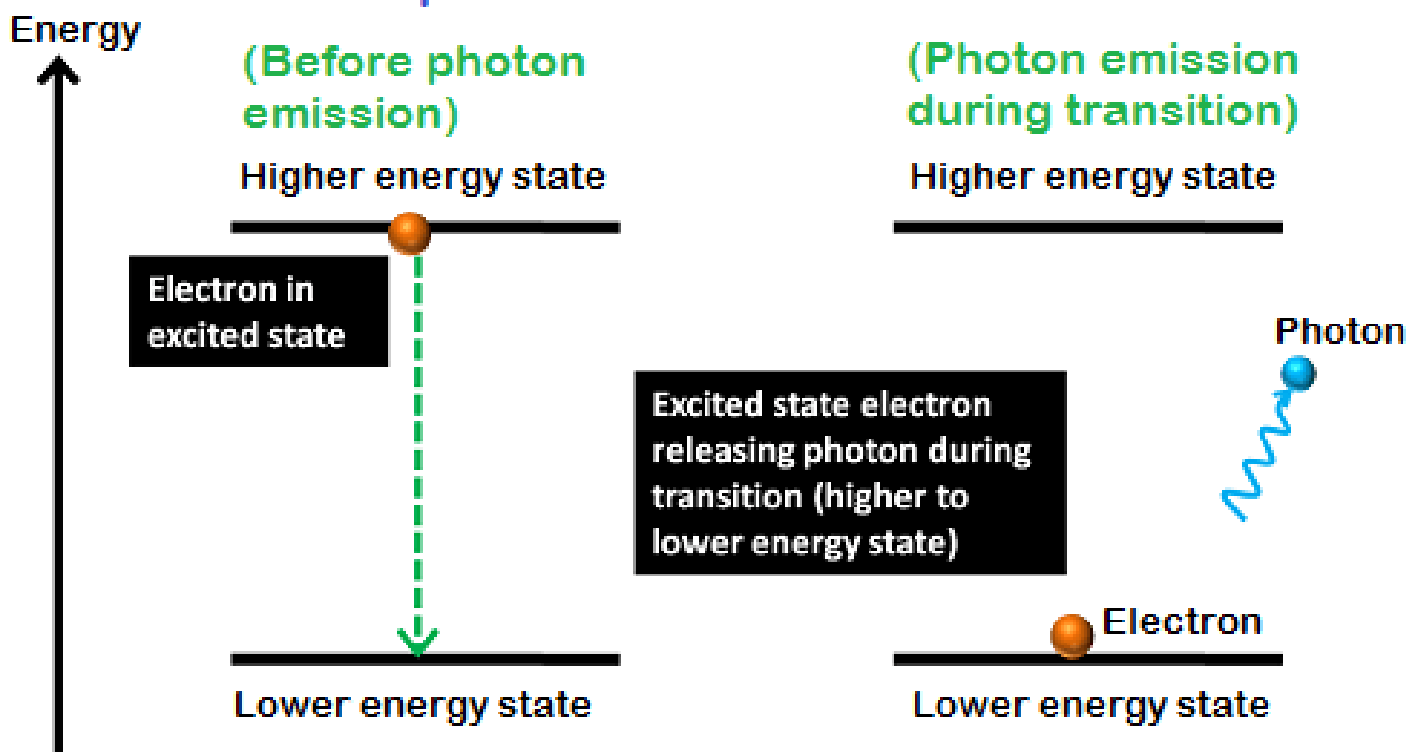

Stimulated Emission

Atoms in an upper energy level can be triggered or stimulated in phase by an incoming photon of a specific energy.

The stimulated photons have unique properties:

- **In phase** with the incident photon
- **Same wavelength** as the incident photon
- Travel in **same direction** as incident photon

Stimulated emission

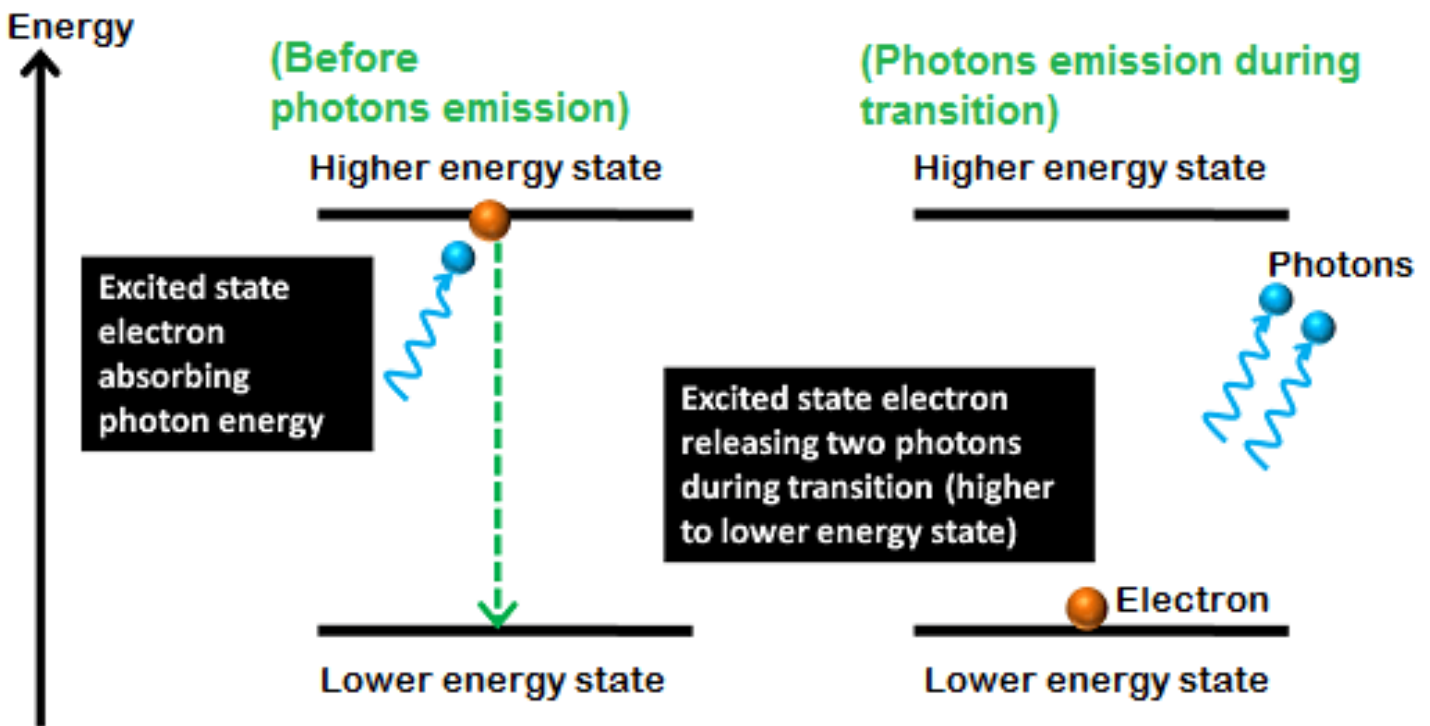

The stimulating radiation in a laser is provided as a result of feedback within a resonant optical cavity. In practice, a laser cavity is normally comprised of a 100% reflecting rear mirror and a partially reflecting front mirror (the partial reflectance is necessary to let some light out of the laser whilst still providing the feedback required for laser action). When illuminated (or "pumped") by a radiation source such as a flash lamp or diode laser, the broadband emission that results from the spontaneous photon emission travels back and forth and experiences the highest gain (amplification) at a frequency determined by the configuration of the resonator and the optical characteristics of the laser medium. That gain leads to all of the photon emissions occurring on the same, chosen, transition in the same direction, and all with the same phase

relationship. This amplification of the stimulated emission of coherent, near-monochromatic, unidirectional photons is what defines laser action.

Spontaneous emission	Stimulated emission
Spontaneous process and automatically produced	Induced by external radiation
No need of population inversion	Requires population inversion
Photons produced are of different energy levels hence incoherent	Same energy levels hence coherent
Photons emitted travel randomly in any direction	Travels in the same direction as the incident photon

Conditions for laser action

1- Population inversion

A state of a medium where a higher-lying electronic level has a higher population than a lower-lying level. Population inversion can be Achieved By a process called pumping.

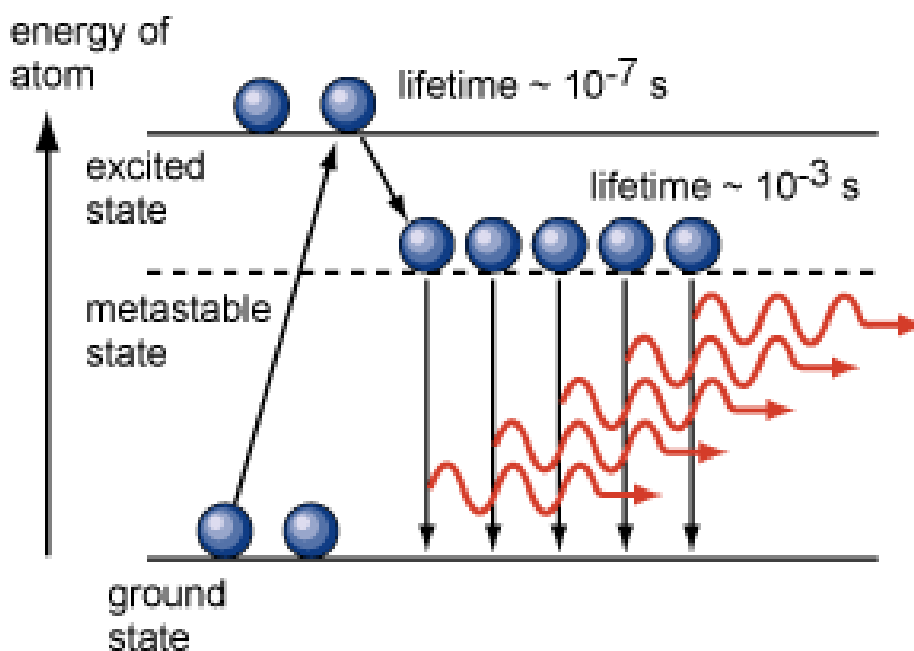

2- Pumping

Mechanism of exciting atoms from the lower energy state to a higher energy state by supplying energy from an external source.

Optical pumping

Atom are excited by means of an external optical source. This is adopted in solid state lasers such as ruby laser and Nd:yag laser.

Electrical pumping

The electrons are accelerated to a high velocity by a strong electric field. This technique of pumping is adopted in gas laser such as CO₂ laser

Direct conversion

In this type pumping, a direct conversion of electric energy into light takes place. This technique of pumping is adopted in semiconductor laser.

3- The metastable state

With having the metastable state above the ground level. Atom reaches the meta stable state (after first stimulated emission) can

remain there for longer time period. So the number of atom increases in the meta stable state.

And when these atoms come back to the original ground level it emits laser beam.

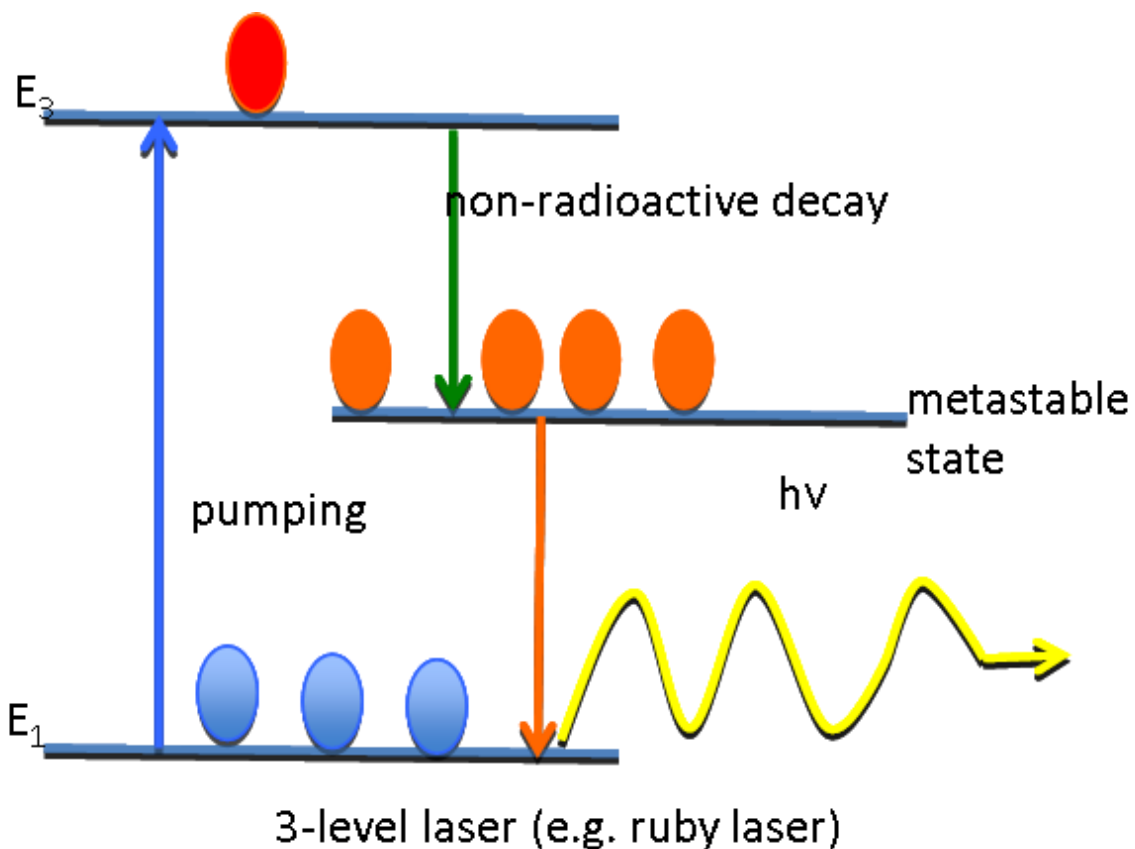
**Common Components of all Lasers****1. Active Medium**

The active medium may be solid crystals such as ruby or Nd:YAG, liquid dyes, gases like CO₂ or Helium/Neon, or semiconductors such as GaAs. Active mediums contain atoms whose electrons may be excited to a metastable energy level by an energy source.

2. Excitation Mechanism

Excitation mechanisms pump energy into the active medium by one or more of three basic methods; optical, electrical or chemical.

3. High Reflectance Mirror

A mirror which reflects essentially 100% of the laser light.

4. Partially Transmissive Mirror

A mirror which reflects less than 100% of the laser light and transmits the remainder.

Lasing Action

1. Energy is applied to a medium raising electron to an unstable energy level.
2. These atoms spontaneously decay to a relatively long-lived, lower energy, metastable state.
3. A population inversion is achieved when the majority of atoms have reached this metastable state.
4. Lasing action occurs when an electron spontaneously returns to its ground state and produces a photon.
5. If the energy from this photon is of the precise wavelength, it will stimulate the production of another photon of the same wavelength and resulting in a cascading effect.
6. The highly reflective mirror and partially reflective mirror continue the reaction by directing photons back through the medium along the long axis of the laser.
7. The partially reflective mirror allows the transmission of a small amount of coherent radiation that we observe as the “beam”.
8. Laser radiation will continue as long as energy is applied to the lasing medium.

Types of Laser

Lasers can classify according to different types according to:

a. Their sources:

1. Gas Lasers
2. Crystal Lasers
3. Semiconductors Lasers
4. Liquid Lasers

b. The nature of emission:

1. Continuous Wave
2. Pulsed Laser

c. Their wavelength:

1. Visible Region
2. Infrared Region
3. Ultraviolet Region
4. Microwave Region
- 5- X-Ray Region

d. Their levels

1. 2-level laser
2. 3-level laser
3. 4-level laser

e. The pumping mode

1. Optical
2. chemical
3. electric discharge
4. electrical

Properties of laser beam

- The light emitted from a laser is **monochromatic**, that is, it is of one colour/wavelength. In contrast, ordinary white light is a combination of many colours (or wavelengths) of light.

- Lasers emit light that is highly **directional**, that is, laser light is emitted as a relatively narrow beam in a specific direction. Ordinary light, such as from a light bulb, is emitted in many directions away from the source.
- The light from a laser is said to be **coherent**, which means that the wavelengths of the laser light are in phase in space and time. Ordinary light can be a mixture of many wavelengths.

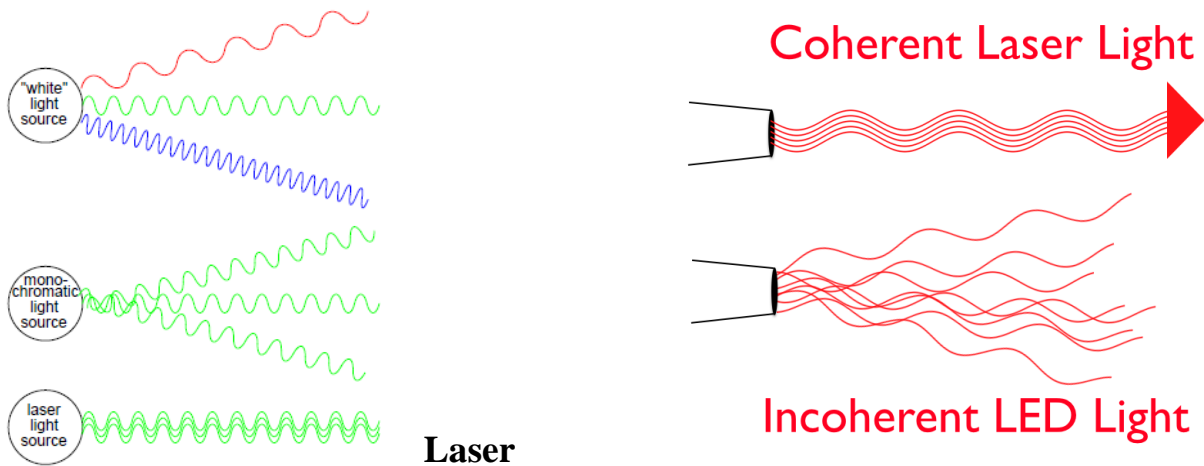

Operating Modes

It is often said that almost any material can be made to lase. Lasers differ not only with respect to the wavelength of the light they produce but also the optical power and the manner in which the power is emitted. Lasers which emit a continuous beam of light are termed "cw" (after continuous wave operation), while other lasers produce an output in the form of pulses of light. For the purpose of classifying their hazards within the laser safety standards, pulsed lasers are placed into different groups depending upon the length of their optical pulses. The table below lists the four groups.

Operating Mode	Designation	Description	Pulse Length
Continuous Wave (CW)	D	A laser that produces a continuous output	> 200ms
Pulsed	I	A laser that produces a single or sequence of periodically repeated pulses	> 1 μ s to 200ms
Giant Pulsed	R	A laser that produces very short pulses (e.g. Q-switched)	1ns to 1 μ s
Mode locked	M	A laser that produces ultrashort pulses (i.e. picosecond or femtosecond)	< 1ns

In the case of pulsed operation with a low pulse repetition frequency (the number of pulses emitted per second), the critical parameter from a laser safety point of view is the peak power of each pulse. If the repetition rate increases, the average power becomes the more dominant parameter. Please note that certain lasers can be operated in more than one mode.

The Four Laser Hazard Classes

Lasers are categorized into four, general hazard classes based upon accessible emission limits or AELs. These limits indicate the class of the laser and are listed in EN 60825-1 and the American National Standard ANSI Z136.1 for the safe use of lasers. The AEL values for the laser classes are derived from the medical MPE (Maximum Permissible Exposure) values. The MPE values specify the danger level for the eye or the skin with respect to the laser radiation. Since November 2001, the laser classes are summarized per the table below.

laser Class	Description
1	This class of laser does not produce dangerous radiation. No need for protective equipment.
1M	This class of laser is eye safe when used without optical instruments but may not be safe if optical instruments are used. No need for protective equipment if used without optical instruments.
2	This class of laser is eye safe as a result of normal human aversion responses, including the blink reflex. No need for protective equipment.
2M	This class of laser has the same powers as a class 2 beam, but the beam divergence and/or diameter may render it unsafe if optical instruments are used. No need for protective equipment if used without optical instruments.
3R	This class of laser emits radiation that exceeds the maximum permissible exposure (MPE). The radiation is a maximum of 5 x AEL of class 1 (invisible) or 5 x AEL of class 2 (visible). The risk is slightly lower than that of class 3B. Dangerous to the eyes, laser safety glasses are recommended.
3B	For this class of laser, the view into the laser is dangerous. Diffuse reflections are not considered as dangerous. This is the old class 3B

	without 3R. Dangerous to the eyes, laser safety glasses are obligatory.
4	This class of laser is inherent unsafe. Even scattered radiation can be dangerous. There is also a danger of fire and a danger to the skin. Personal safety equipment is necessary (glasses, screens).

Biological effects of laser radiation

- **Thermal effects** occur when laser radiation is absorbed by the obstacle (skin). They induce tissue reaction, related to the organism temperature elevation and to the duration of the heating process. Depending on the temperature elevation, different reactions can occur:
 - **Hyperthermia:** The temperature rises of only a few degrees. A 41°C temperature during a few tens of minutes can induce cellular death.
 - **Coagulation:** It corresponds to an irreversible necrosis without immediate tissular destruction. During this process, the tissue temperature can reach temperatures between 50°C and 100°C during about 1s. This induces dessication, whitening and retraction of tissues due to protein and collagen denaturation. Tissues will afterwards be eliminated (deterision processes) and the wound will scar.
 - **Ablation:** it corresponds to matter loss. This process occurs at temperatures higher than 100°C. In these conditions, the cell constituting elements evaporate within a relatively brief time. At the borders of the ablated area, one observes a necrosis coagulated area, as the temperature decreases continuously from the injured to the healthy tissues.
 - Hazard related to the use of pressurized gas bottles.
- **Mechanical effects:** They are caused by the creation of a plasma, by an explosive vaporization, or by a cavitation phenomenon. These effects are mainly related to the expansion of a shock wave (created consequently to thermal effects), which in turns has destructive effects. Indeed, when ejecting matter from the substrate, the latter moves backward. This movement is due to the energy/momentum conservation, and to the fact that a part of the electromagnetic energy is converted into kinetic energy.

Types of Laser Hazards

- **Eye** : Acute exposure of the eye to lasers of certain wavelengths and power can cause corneal or retinal burns (or both). Chronic exposure to excessive levels may cause corneal or lenticular opacities (cataracts) or retinal injury.
- **Skin** : Acute exposure to high levels of optical radiation may cause skin burns; while carcinogenesis may occur for ultraviolet wavelengths (290-320 nm).
- **Chemical** : Some lasers require hazardous or toxic substances to operate (i.e., chemical dye, Excimer lasers).
- **Electrical** : Most lasers utilize high voltages that can be lethal.
- **Fire** : The solvents used in dye lasers are flammable. High voltage pulse or flash lamps may cause ignition. Flammable materials may be ignited by direct beams or specular reflections from high power continuous wave (CW) infrared lasers.

References

- 1- University Physics with Modern Physics, by H. D. Young and R. A. Freedman, Addison-Wesley, 14e, ISBN 9780321973610 (2015).
- 2- R.A. Serway, J.W.Jewett, Physics for Scientists and Engineers, With Modern Physics, Translation of 8th American Edition, ISBN 978-960-461-509-4, Klidarithmos Publications, 2013, Athens (Greek Edition).
- 3- Physics: concepts & connections" · Hobson, A. · Harlow: Pearson Education, 2014.
- 4- <https://en.wikipedia.org/wiki/Physics>
- 5- <http://hyperphysics.phy-astr.gsu.edu/hbase/index.html>
- 6- <https://www.britannica.com/science/light>