



# Radiation Physics

اعداد

دكتور/ أبو الوفا أبو المعارف محمد سالم

كلية العلوم قسم الفيزياء

العام الجامعي

2023/2022

## Atomic nomenclature

1. **Elements:** There are (92) elements in the nature started with hydrogen and ending with uranium, many new elements are originate by adding neutrons to the nucleus atom until it increased to (118) elements.
2. **Nucleons:** Protons or neutrons.
3. **Radioactive nuclide:**  ${}^A_ZX$  unstable nucleus.
4. **Neutral Atom:** Atom has equal number of electrons and protons.
5. **Atomic Number (Z):** Number of protons in the nucleus.
6. **Atomic Mass Number (A):** Number of (protons+neutrons) in the nucleus.
7. **Isotopes:** atoms have the same number of protons (Z).  ${}^{132}_{56}\text{Ba}$  ,  ${}^{134}_{56}\text{Ba}$
8. **Isotones:** The atoms have the same number of neutrons (A-Z).
9. **Isobars:** The atoms have the same atomic mass number (A).
10. **Isomers:** Isomers have the same atomic number and the same atomic mass.

Isomers exist at different energy states because of differences in the nucleon arrangement.  ${}^{99m}_{43}\text{Tc}$  which decays with a half-life of 6 hours, by emitting a gamma is example of isomer. Metastable isomers designated by "m", in the case of more than one isomer, its denoted by m1, m2, m3, and so on, this correlate with increasing levels of excitation energy states (e.g., hafnium

${}^{177m2}_{72}\text{Hf}$ ).

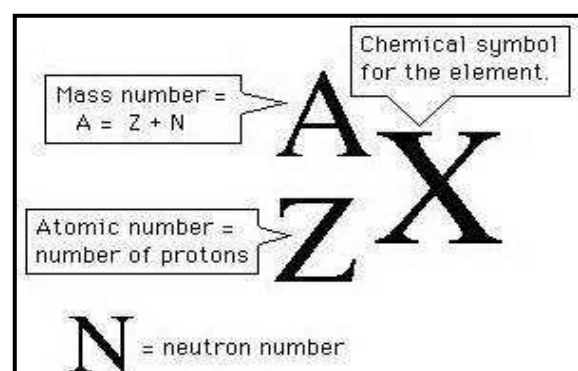

**11. Isodiapheres:**

Atoms have the same difference between neutron and proton ( $N - Z$ ), or the It's the nuclide that emitted alpha particles. ( $^{234}_{90}\text{Th}$  and  $^{238}_{92}\text{U}$ ) where  $N - Z = 54$ . In thorium proton number is 90 and neutron number is 144  $144 - 90 = 54$ , in uranium proton number is 92 and neutron number is 146  $146 - 92 = 54$ .

**12. Transuranium** (transuranic elements): the elements with atomic numbers greater than 92 (atomic number of uranium). All of them are unstable and decay radioactively into other elements. Transuranic artificially generated, via nuclear reactors or particle accelerators. Their half-lives decrease as atomic numbers increase. 93. Neptunium (Np), 95. Americium (Am), 94. Plutonium (Pu) , 98. Californium, (Cf) etc. are examples of transuranium.

It is the transfer or the emission of energy as either waves or particles. It comes from a source and travels through some material or through space. It is produced by radioactive decay, nuclear fission and nuclear fusion, chemical reactions, hot objects. it separate into ionizing and non-ionizing.

### 1. Ionizing radiations:

It is the radiations that excite and ionize atoms of matter with which they interact, it includes: particulate and electromagnetic radiation.

#### a. Particulate ionizing radiation: it includes

##### 1. **Charged particles:** it's directly ionized matter, such as;

1. Fast electron (beta, positron).
2. Heavy Charged Particle :
  - a. Proton-the hydrogen nucleus.
  - b. Deuteron-the deuterium nucleus, consisting of a proton and neutron.
  - c. Triton-a proton and two neutrons, tritium nucleus.
  - d. Alpha - helium nucleus, (two protons and two neutrons).

##### e. Nuclear fragments.

- Uncharged particles:

Its indirect ionizes matter such as neutron.

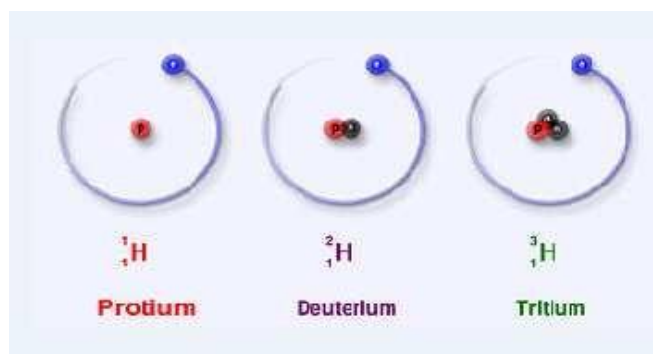

#### b. Electromagnetic ionizing radiation:

It is the very short wave-length part of the electromagnetic spectrum; with wavelengths up to **320** nm. It includes **U.V.**, **gamma** and **X-ray**.

## 2. Nonionizing radiations:

It is the radiations that do not have a sufficient energy to remove electrons from atoms, and hence can't interact with matters or ionizing them. Such visible, infra-red (heat), microwaves, radiowaves, and laser. Nonionizing particulate includes molecules, atoms, and ions.

### Alpha particles ( $\alpha$ ):

- It's a helium nucleus containing two protons and two neutrons.
- Its mass is 4amu.
- It's emitted only from the nuclei of heavy elements. e.g.  $^{226}\text{Ra}$ ,  $^{238}\text{U}$ ,  $^{239}\text{Pu}$ .
- Its average kinetic energy is (4-7Mev).
- Its ionize 40,000 atoms for every cm of travel through air.
- It has a very short rang, in air is 5cm, in soft tissue is less than 100  $\mu\text{m}$ .
- Alpha emission occurs in nuclei have excess protons.
- Alpha decay is represented by:  ${}^A_Z\text{X} \rightarrow {}^{A-4}_{Z-2}\text{X} + {}^4_2\text{He}$
- When it is ejected from a nucleus, the mass number of the nucleus decreases by four and the atomic number decreases by two. For example:  $^{238}_{92}\text{U} \rightarrow ^{234}_{90}\text{Th} + {}^4_2\alpha$ .

### Alpha range:

Air is the absorbing medium for specifying range-energy relationships of alpha. The range (in cm) of air, ( $R_a$ ), of alphas whose energy  $E$  is between (2 MeV - 8 MeV) is:  $R_a = 0.322E^{3/2}$

Beta particles ( $\beta$ ):

- It is emitted during the radioactive decay of some unstable atoms.
- It's emitted by the conversion of the proton into a neutron (or vice-versa).
- Its atomic mass number = (0).
- It's less ionizing than alpha radiation, but more than gamma.
- Its traverse (10-100cm) in air, and (1-3 cm) in soft tissues.
- It can be stopped with a few centimeters of plastic or a few millimeters of metal.
- Its ionize several hundred atoms/cm
- The nucleus emits beta, is emit (either an electron or a positron) and neutrino.

Thus A is constant, but Z and N change by 1:  $^{131}_{53}\text{I} \rightarrow ^{131}_{54}\text{Xe} + ^0_{-1}\beta$

- Negative charge beta (electron) emitted as a result of the transformation of neutron into proton, electron and antiquark neutrino:  $^1_0n \rightarrow ^1_1p + ^0_{-1}e + \bar{\nu}$
- Positive beta charge (positron) emitted as a result of the transformation of the proton into neutron, electron and neutrino:  $^1_1p \rightarrow ^1_0n + ^0_{+1}e + \nu$

2. Uncharged particles (Neutron):

- Its mass 1/4 of alpha and 2000 times of a beta.
- Has no electrical charge.
- It has the potential to penetrate matter deeper than any other charged particles but this.

Gamma ray ( $\gamma$ ):

- It's a monochromatic radiation.
- It has no mass and no charge.
- It's energy above 100keV (from 0.1 to 3MeV).
- It ionizes 100 ions pairs/cm.
- Its wavelength between (0.05-0.005 A°).
- It's emission of electromagnetic radiation from of unstable nucleus and accompanying with alpha or beta.

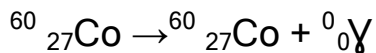

- Its emission unchanged atomic and mass numbers.

Radiation	A.M.N	Charge	energy	Range in		
				air	Soft tissue	origin
alpha	4	+2	4-7Mev	1-10cm	0.1mm	nucleus
beta	0	-1	< 6Mev	<10m	3cm	nucleus
gamma	0	0	< 10Mev	<100m	30 cm	nucleus
X-rays	0	0	<1 Mev	Up to100m	30cm	Electron cloud

**Nuclear Binding energy:**

It is the energy required to split the nucleus apart (protons & neutrons), or the energy liberated by combining protons and neutrons into a single nucleus.  ${}^{63}\text{Cu} +$  (B.E.)  $\rightarrow {}^{29}\text{p} + {}^{34}\text{n}$

The mass of a nucleus is less than the sum of masses of the protons and neutrons which constitute it. The difference is the nuclear binding energy which holds the nucleus together.

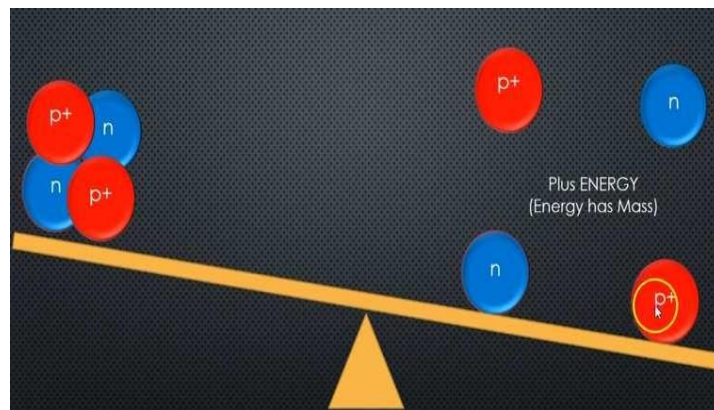

**Example:** Calculate the binding energy of deuterium ( ${}^2_1\text{H}$ ):  ${}^1_1\text{P} + {}^1_0\text{n}$ . If the mass of  ${}^2_1\text{H} = 2.01410\text{u}$ ; of proton =  $1.007825\text{u}$  and, of neutron =  $1.008665\text{u}$ .

**Sln:**

Mass of defects = mass of constituents - mass of isotope

$$\Delta m = [1 \times 1.007825 + 1 \times 1.008665] - 2.01410$$

$$= 2.01649 - 2.01410$$

$$= 0.00239 \text{ amu}$$

By using conversion factor (energy  $\leftrightarrow$  mass) =  $931.5 \text{ MeV/amu}$ .

B.E. =  $0.00239 \text{ amu} \times 931.5 \text{ MeV/amu} = 2.226285 \text{ MeV}$  for the nucleus.

B.E. for the nucleon =  $2.226285 \text{ MeV} / 2 = 1.1131425$ .

## Radioactive decay



It is the spontaneous release off energy from heavy atoms into:

- New element by emitted  $\alpha$ ,  $\beta^-$ ,  $\beta^+$ , proton.
- New isotope by emitted neutron.
- The same isotope of the element by emitted gamma.

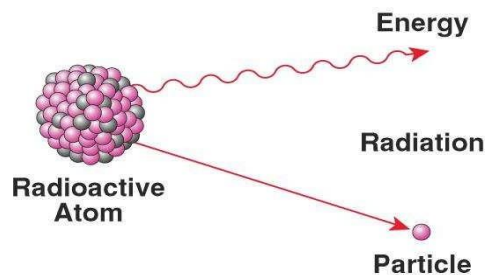

### **Activity:**

It's the number of atoms decay per unit time (disintegrations /s), it's measured by curie (Ci) or Becquerel (Bq).

### **Becquerel:**

1. It is very small unit, and multiples of Becquerel is commonly used (1 kBq= $10^3$  Bq, 1 MBq =  $10^6$  Bq, 1 GBq= $10^9$  Bq).
2. 1Bq = 1 disintegration per second (dps) or (d/s).

### **Curie:**

1. It is the activity of one gram of pure radium.
2. 1Ci = $3.7 \times 10^{10}$ Bq.
3. It's the old unit of activity.
4. It is very large amount of activity.
5. Sub-multiples of curie are commonly used; mCi,  $\mu$ Ci, nCi, pCi.

### **Law of radioactive decay:**

Unstable nuclei decay spontaneously and randomly, this process doesn't occur quickly, if it was done quickly, there were no radioactive elements heavier than lead on the earth's surface.

That means the radioactivity or disintegration rate relative to time ( $dN/dt$ ) is proportional to the number of radionuclides remain without disintegration ( $N$ ) after time ( $t$ ).

$-dN/dt \propto N$                       the negative sign means  $N$  decrease as time increase.

$dN/dt = -\lambda N$                       ( $\lambda$ ) is the decay constant in( $s^{-1}$ ), and constant for isotope.

$dN/N = -\lambda dt$                       by the integration .

$\ln [N] = -\lambda t$

$\ln(N) - \ln(N_0) = -\lambda t$

$\ln N/N_0 = -\lambda t$

$$N/N_0 = e^{-\lambda t}$$

$$\boxed{N(t) = N_0 e^{-\lambda t}}$$

...(1)                      law of radioactive decay

Where:

**$N(t)$** : number of radionuclides remaining without disintegration at any time( $t$ ).

**$N_0$**  : is the initial number of radionuclides at  $t = 0$ .

**The activity  $A(t)$ :**

It's the number of nucleus disintegrate in one second, it decreases exponentially with time, and It is defined as the radioactivity of the sample.

$$A(t) = - dN(t)/dt$$

$$A(t) = - d(N_0 \cdot e^{-\lambda t})/dt \quad \text{by substituting N with eq.(1)}$$

$$A(t) = \lambda N_0 \cdot e^{-\lambda t} \quad \dots(2) \quad \text{by differentiation.}$$

$$A(t) = \lambda N(t) \quad \dots(3) \quad \text{by substitute } N_0 \cdot e^{-\lambda t} \text{ with } N(t).$$

$$A(t) = A_0 \cdot e^{-\lambda t} \quad \dots(4) \quad \text{because } A_0 = \lambda N_0 \text{ at } t=0 .$$

Where  $A_0$  :is the initial activity of the sample at  $t=0$ .

### The half-life( $t_{1/2}$ ):

The time required for the activity of any radionuclide to decrease to one-half of its initial value. Range from microseconds to billions of years. Radium has a half-life of 1620 years; therefore, starting with 1Kg of radium, 0.5Kg remains as radium after 1620 years, 0.25Kg after 3240 years and so on

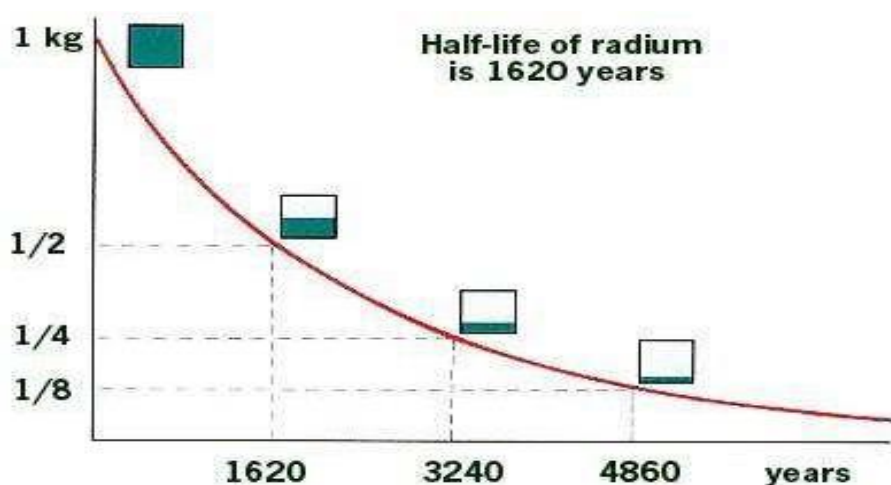

Using equation ( 1)  $N(t) = N_0 \cdot e^{-\lambda t}$

$$N(t_{1/2}) = N_0 e^{-\lambda t_{1/2}} = N_0 \cdot \frac{1}{2} \quad \rightarrow \quad e^{-\lambda t_{1/2}} = \frac{1}{2} \quad \text{at} \quad t = t_{1/2}$$

$$-\lambda t_{1/2} = \ln \frac{1}{2} = -\ln 2 \quad \rightarrow \quad t_{1/2} = \frac{\ln 2}{\lambda}$$

$$\boxed{t_{1/2} = 0.693 / \lambda} \quad \dots(6) \quad \text{because } \ln(2)=0.693$$

### **Mean or average life ( $\bar{T}$ ):**

It is the summation of the lifetimes of the individual atoms divided by the total number of atoms originally present.

$$\bar{T} = 1 / \lambda$$

$$\bar{T} = (t_{1/2}) / 0.693$$

$$\bar{T} = 1.45(t_{1/2})$$

### **Specific activity (SA):**

It is the activity per unit mass, or Bq(or ci) /mass(or volume).

$$A = \lambda N, \quad N = \frac{6.03 \times 10^{23} \text{ atoms/g}}{M}, \quad M = \frac{a}{w(g)}, \quad \text{,W: weight, a: atomic weight}$$

$$SA = \frac{A}{w} = \frac{\lambda N}{W(g)} = \frac{\lambda}{W(g)} \times \frac{6.03 \times 10^{23} \text{ Bq/g}}{a/w(g)}$$

$$SA = \frac{\lambda \times 6.03 \times 10^{23} \text{ Bq/g}}{a}$$

$$SA = \frac{0.693}{t_{1/2}} \times \frac{6.03 \times 10^{23}}{a},$$

$$SA = \frac{4.18 \times 10^{23} \text{ Bq/g}}{t_{1/2} \times a} \quad \dots (7) \quad \lambda \text{ and } t_{1/2} \text{ are given in seconds.}$$

**Q1:** One microgram ( $10^{-6}$  g) radium is found to emit  $3.7 \times 10^4$  alpha particles /second. If each of these alphas represents a radioactive transformation of radium, what is the decay constant for radium?

**Sln:**

In this case:  $dN = 3.7 \times 10^4$  ,  $dt = 1$  second,

$$N = \frac{\text{number of radium atoms}}{\text{Mass of one mole (M)}} = \frac{\text{Avogadro's number}}{1 \text{ Microgram}}$$

$$N = \frac{6.03 \times 10^{23} \text{ atoms/mole} \times W(\text{g})}{a (\text{atomic no. (g /mole)})}$$

Where :  $a = 226$  the atomic weight of radium.

$W = 1 \times 10^{-6}$  g the weight of the radium sample.

$$N = \frac{(6.03 \times 10^{23}) \times 10^{-6}}{2.26 \times 10^2} = 2.66 \times 10^{15} \text{ atoms}$$

The decay constant, therefore is:

$$\lambda = \frac{dN/N}{dt} = \frac{3.7 \times 10^4 \text{ atoms}/2.66 \times 10^{15} \text{ atoms}}{1 \text{ sec}} = 1.39 \times 10^{-11} \text{ sec}^{-1}$$

**Q2:** If the decay constant ( $\lambda$ ) of Ra-226 is  $4.38 \times 10^{-4}$  /year, calculate:

1. The half -life ( $t_{1/2}$ )
2. Activity of 1 microgram.

**Sln:**

$$1. t_{1/2} = 0.693 / \lambda = 0.693 / 4.38 \times 10^{-4} \text{ yr}^{-1} = 1.6 \times 10^3 \text{ years.}$$

$$2. A = \lambda N = 2.66 \times 10^{15} \text{ atoms} \times 1.39 \times 10^{-11} \text{ s}^{-1} = 31.414 \times 10^4 \text{ atom/s.}$$

That is, the number of atoms decays /second in one microgram of radium are 314140.

**Q3:** What is specific activity of radium if;  $a = 226$  gm/mole,  $t_{1/2} = 1600y$ .

Sln:

$$S.A = \frac{6.03 \times 10^{23} \text{ atoms/mole}}{226} \times \frac{0.693}{1600y} \times \frac{1y}{365d} \times \frac{1d}{24h} \times \frac{1h}{60min} \times \frac{1m}{60sec}$$

$$S.A. = \frac{3.66 \times 10^{10} \text{ atoms}}{g \cdot sec} = \frac{3.66 \times 10^{10}}{g} \text{ Bq}$$

$$S.A = 3.66 \times 10^{10} \text{ Bq/g} = 3.7 \times 10^{10} \text{ dps} = 1\text{Ci exactly.}$$

**Q4:** What is the remaining mass of a sample of 100 g of U -232 after 250 years?

If you know that the half-life of uranium-232 is 68.9 years.

$$A(t) = A_0 \cdot e^{-\lambda t}$$

$$A(t) = 100 \cdot e^{-(0.693/68.9)/250}$$

$$A(t) = 100 \cdot e^{-0.01/250}, \quad A(t) = 100 \cdot e^{-2.5}$$

$$A(t) = 100 \times 0.082$$

$$A(t) = 8.2 \text{ gm}$$

**Q5:** A radioactive material of 20gm, have 12.5 years. Who much gm of the sample will remain after 20years?

**Q6:** A radioactive material of 30gm and half-life of 1day. How much grams of sample will remain after 5days?

Sln 1:

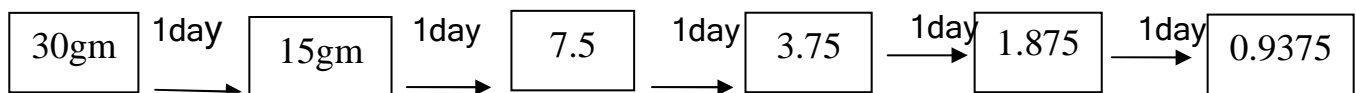

Sln2:

$$N(t) = N_0 e^{-\lambda t}, \quad N = 30 \times e^{-(0.693/1) \times 5} = 30 \times e^{-3.465} = 30 \times 0.03127 = 0.938 \text{ gm}$$

## Units of radiation

**1. Roentgen (R):** The only unit used to measure the exposure to X-ray or gamma radiation.

### **Units of radiation absorbed dose (D):**

a. **Rad**: It's the amount of any type of radiation (not only X or  $\gamma$ ) which transfer (0.01J) to a (kg) of any exposed mater. It's a biological unit, used to describe the quantity of radiation received by a patient.  $1 \text{ rad} = 0.01 \text{ Gy} = 0.01 \text{ J/kg}$ .

b. **Gray**: The radiation dose expressed as [absorbed energy/mass of tissue]:  
 $1\text{Gy} = 1\text{J/Kg} = 100\text{Rad}$

### **3. Units of equivalent dose (H):**

a. **Rem (Roentgen equivalent man)**: Equal doses of different ionizing radiation provide the same amount of energy in a given absorber but they may not have the same biological effect on the human body. it is defined by: Dose in rems= Dose in rads x R.B.E.

(R.B.E.): relative biological effectiveness. Some experimental values of R.B.E. named by quality factors (QF) are used to estimate the radiation risk on the human.

QF	Radiation type
1	Gamma ray ,and X-ray
3	Thermal neutrons
10	Fast neutrons, protons, and alpha
20	Heavy ions

b. **Sievert (Sv)**: It's the unit of radiation absorption in (SI).

$$1\text{Sv} = 1\text{Gy} = 100 \text{ rads} = 100 \text{ rem} = 1\text{J/kg}$$

## **Sources of Radiation**

There are two main sources of radiation:

### **a. Naturally occurring (background radiation):**

It is naturally present in our environment since the birth of this planet. It includes:

#### **A. Cosmic radiation:**

The earth, and all living things on it, are bombarded by radiation from space (sun and stars), this radiation interact with the Earth's atmosphere and magnetic field (typically beta and gamma). The dose from cosmic radiation varies in different parts of the world due to differences in elevation and the effects of the earth's magnetic field.

#### **B. Terrestrial radiation:**

The major isotopes of terrestrial radiation are uranium and the decay products of uranium, such as thorium, radium. Low levels of these elements and their decay products are found everywhere, and ingested with food and water.

The dose from terrestrial sources varies in different parts of the world. Locations with higher concentrations of uranium and thorium have the higher dose levels in their soil.

#### **C. Radon gas:**

It is the largest natural source of radiation exposure to humans, which exist on air, water and soil. Radon's pathway is from the earth, through the basements of houses and other buildings, and into inside air that people breathe. Radon exposures can vary depending on the soil and rock structure beneath buildings.



**D. Natural internal radiation in human body:**

It is the internal radiation comes from radioactive materials occur naturally in the human body. Potassium and Carbon are the primary sources of internal radiation exposures. The Potassium K-40 isotope enter the human body through the food chain. Carbon C-14 (represent 0.23 weight of the human body) enters the body both through the food chain and breathing.

**b. Artificial sources (man-made radiation):**

Artificial radiation sources are identical to the natural radiation in their nature and effect. The most important sources are:

1. Medical procedures: diagnostic X-rays, nuclear medicine, and radiation therapy.
2. Consumer products: tobacco (polonium-210), building materials, fuels (gas, coal, etc.).
3. Concern isotopes: cobalt ( $^{60}\text{Co}$ ), cesium ( $^{137}\text{Cs}$ ), americium ( $^{241}\text{Am}$ ), others.

**Table 1: Annual effective dose equivalent.**

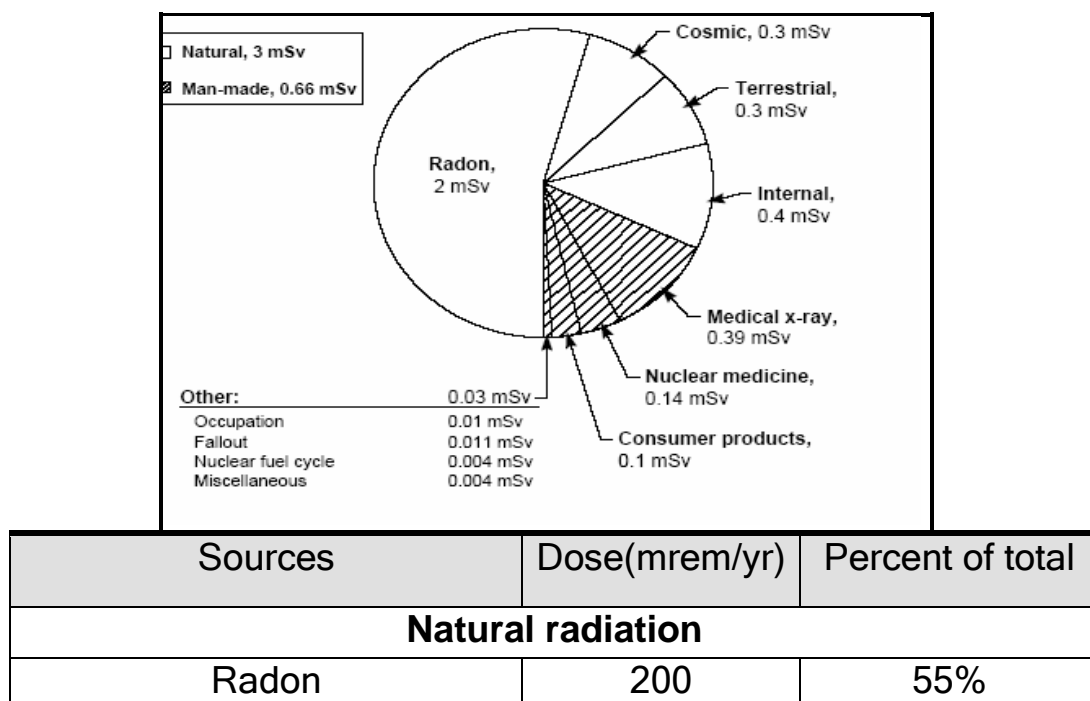

## Radiation Physics

Cosmic	27	8%
Terrestrial(rocks and soil)	28	8%
Internal (inside human body)	40	11%
<b>Total natural</b>	<b>295</b>	<b>82%</b>
<b>Man-made radiation</b>		
Medical X-ray	39	11%
Nuclear medicine	14	4%
Consumer products	10	3%
Other	-	-
Occupational	0.9	<0.3%
Nuclear fuel cycle	<1	<0.03%
<b>Total artificial</b>	<b>65</b>	<b>18%</b>
<b>The total</b>	<b>360</b>	<b>100%</b>

**Q: what is the licensee's limit of exposure to man-made radiation?**

It is **(1mSv per years)** for public exposure (individual members) and **(50mSv/year)** for occupational exposure (working with radioactive material).

**Q: what is the average exposure of person?**

Its (3.6mSv/yr), 81% of it comes from the exposure to natural sources. 19% comes from the exposure to the artificial sources.

Note: 1mSv =100 mrem

## Uranium

All isotopes of uranium undergo the same chemical reactions and possess identical physical characteristics, such as melting point and boiling point. Natural uranium, enriched uranium and depleted uranium (DU) vary only according to their isotopic composition, and therefore have identical chemical reactions, and exert the same. All of the uranium isotopes decay to shorter-lived decay products often referred to as “daughters”.

### **Properties and occurrence natural uranium:**

1. Discovered in 1789 by German chemist (Martin Klaproth) who found uranium as part of the mineral called pitchblende.
2. It is a hard, ductile, silver-white, natural occurring metal.
3. It is atomic number 92, atomic mass 238, and 92 protons and 92 electrons.
4. It is the heaviest naturally occurring element.
5. It's a dense metal, its density  $19\text{g/cm}^3 >$  lead density ( $11.3\text{g/cm}^3$ ).
6. In nature it occurs in oxidized form e ( $\text{UO}_3$ ) or ( $\text{UO}_2$ ).
7. It occurs with low concentrations in soil, rock, sea, drinking water and food.
8.  $90\mu\text{gm}$  (micrograms) of uranium exist in human body from normal intakes of water, food and air; 66% is found in the skeleton, 16% in the liver, 8% in the kidneys and 10% in other tissues.
9. All uranium isotopes have the same chemical properties because they all have the same number of protons (92), but different radiological properties.

### **2. Radiological properties:**

1. Natural uranium consists of a mixture of three radioactive isotopes  $^{238}\text{U}$ ,  $^{235}\text{U}$  and  $^{234}\text{U}$ .
2. All uranium isotopes are radioactive.
3.  $^{235}\text{U}$  &  $^{238}\text{U}$  are the origin of two different decay chains.
4.  $^{238}\text{U}$ ,  $^{235}\text{U}$ ,  $^{234}\text{U}$  Abundances are 99.27%, 0.72% and 0.0054% respectively.

### **3. Uranium isotopes:**

#### **a. Uranium-238:**

It is the head of the uranium decay series of which U-234 is a member, and it has abundance 99.27% and half-life 4500 million years. Its typical concentration in soil is (1pCi/g).

#### **b. Uranium-235:**

$^{235}\text{U}$  is the head of the actinium decay series with abundance 0.71%, and half-life 710million years, its typical concentrations in soil is (1 pCi/g).

#### **c. Uranium-234 :**

With abundance (0.0059%), and half-life 244000 years.

### **Uranium decay chains**

U-238 and U-235 together with their decay products form a “decay chain” or “series” the final decay product of which is a stable isotope of lead. These decay series include alpha, beta and gamma emitter's natural uranium has two decay chains:

**a. Uranium-238 series ( $^{238}_{92}\text{U}_{146}$ ):**

It is the longest chain beginning with U-238 , ending with stable Pb-209. Contains 16 isotopes all are solid except the radon gas (its half-life is 3.8 days) which represents the feature of this series. Its atomic mass is calculated from this relation  $(4n+2)$  i.e. its atomic mass divided by 4 and leaves a remainder 2, n is a number from (59-51).

nuclide	name	decay mode	half-life	Energy (MeV)
$^{238}\text{U}$	Uranium	$\alpha$	$4.468 \cdot 10^9$ a	4.270
$^{234}\text{Th}$	Thorium	$\beta$	24.10 d	0.273
$^{234\text{m}}\text{Pa}$	Protactinium	$\beta$ 99.84%	1.16 min	2.271
$^{234}\text{U}$	Uranium II	$\alpha$	245500 y	4.859
$^{230}\text{Th}$	Thorium	$\alpha$	75380 y	4.770
$^{226}\text{Ra}$	Radium	$\alpha$	1602 y	4.871
$^{222}\text{Rn}$	Radon	$\alpha$	3.8235 d	5.590
$^{218}\text{Po}$	Polonium	$\alpha$ 99.98%	3.10 min	6.115
$^{214}\text{Pb}$	lead	$\beta$	26.8 min	1.024
$^{214}\text{Bi}$	Bismuth	$\beta$ 99.98%	19.9 min	3.272
$^{214}\text{Po}$	Polonium	$\alpha$	0.1643 ms	7.883
$^{210}\text{Pb}$	lead	$\beta$	22.3 a	0.064
$^{210}\text{Bi}$	Bismuth	$\beta$ 99.999%	5.013 d	1.426
$^{210}\text{Po}$	Polonium	$\alpha$	138.376 d	5.407
$^{206}\text{Pb}$	lead	-	stable	-

**b. Actinium series (U-235):**

It begins with  $^{235}\text{U}$ , ending with stable lead-207, consists of 12 isotopes, its atomic mass is calculated from this relation  $(4n+3)$  i.e. All its elements are solid except Actinon-219 gas  $^{219}\text{Rn}$  (its half-life is 3.96 s) which represents the feature of this series. Its atomic mass divided by 4 and leaves a remainder 3,  $n$  is a number from (58-51).

No.	nuclide	name	decay mode	half-life	energy
1	$^{235}\text{U}$	Uranium	$\alpha$	$7.04 \cdot 10^8$ y	4.678
2	$^{231}\text{Th}$	Thorium	$\beta$	25.52 h	0.391
3	$^{231}\text{Pa}$	Protactinium	$\alpha$	32760 y	5.150
4	$^{227}\text{Ac}$	Actinium	$\beta$ 98.62%	21.772 y	0.045
5	$^{227}\text{Th}$	Thorium	$\alpha$	18.68 d	6.147
6	$^{223}\text{Fr}$	Francium	$\beta$ 99.994%	22.00 min	1.149
7	$^{223}\text{Ra}$	Radium	$\alpha$	11.43 d	5.979
8	$^{219}\text{Rn}$	Actinon	$\alpha$	3.96 s	6.946
9	$^{215}\text{Po}$	Polonium	$\alpha$	1.781 ms	7.527
10	$^{211}\text{Pb}$	lead	$\beta$	36.1 min	1.367
11	$^{207}\text{Tl}$	Thallium	$\beta$	4.77 min	1.418
12	$^{207}\text{Pb}$	lead	—	stable	—

### c. Thorium series (Th-232):

Pure thorium is a silvery-white metal it is the second radioisotope coming after uranium. Its atomic mass is 90, mass number is 232, its melting point is  $1750^\circ\text{C}$ , its boiling point  $4700^\circ\text{C}$ , and its density is  $(11.72\text{gm}/\text{cm}^3)$  it exists in very little concentration in the nature. Thorium series starting with Th-232, ending with stable Pb-208, consists of 13 isotopes all are solid except the Thoron gas ( $^{220}\text{Rn}$ ) its half-life is (55.3 seconds) which represent the feature of this series. Its atomic

mass is calculated from this relation  $(4n)$  i.e. its atomic mass divided by 4 and the remainder is zero.  $n$  is a number from (58-52).

NO.	Isotopes	decay mode	Halif_life $T_{1/2}$
1	${}^{232}_{90}\text{Th}_{142}$	Alpha	$1.41 \times 10^{10}$ y
2	${}^{226}_{88}\text{Ra}_{200}$	Beta	5.7y
3	${}^{226}_{89}\text{Ac}_{139}$	Beta	6.13h
4	${}^{220}_{90}\text{Th}_{139}$	alpha	1.91y
5	${}^{224}_{88}\text{Ra}_{136}$	alpha	3.64d
6	${}^{220}_{86}\text{Rn}_{134}$	alpha	<b>55.3sec</b>
7	${}^{210}_{84}\text{Po}_{132}$	Beta	0.15sec
8	${}^{210}_{85}\text{At}_{131}$	alpha	$3 \times 10^{-4}$ sec
9	${}^{212}_{82}\text{Pb}_{130}$	Beta	10.64h
10	${}^{212}_{83}\text{Bi}_{129}$	Beta	6.06m
11	${}^{212}_{84}\text{Po}_{128}$	alpha	$3 \times 10^{-7}$ sec
12	${}^{206}_{81}\text{Tl}_{127}$	Beta	3.1m
13	${}^{206}_{82}\text{Pb}_{126}$	-	Stable

### Depleted Uranium (DU) properties:

1. It is available since 1940.
2. It's a by-product of the enrichment process of natural uranium to make nuclear fuel. It remains after the removing of the enriched fraction ( ${}^{235}\text{U}$ ), and the remaining of the heavy and low radioactive isotope ( ${}^{238}\text{U}$ ).
3. Contains 99.8%  ${}^{238}\text{U}$ , 0.2%  ${}^{235}\text{U}$  and 0.0006%  ${}^{234}\text{U}$ .
4. DU is less radioactive than natural uranium by 60%.
5. Its dense metal, about twice that of lead.
6. It has a high penetration power.
7. Burning spontaneously when in contact with air.

**The main uses of DU depend on some properties which are:**

- a. Available and Inexpensive.
- b. Very dense metal; provide a large mass in a small volume.
- c. Higher penetrative power and greater trajectories.
- d. Very hard.
- e. Pyrophoric (Burning spontaneously).

**a. Civilian applications of depleted uranium:**

- 1. Coloring matter for porcelain and glass (in 19th century).
- 2. Dental porcelain crowns (until 1982).
- 3. Counterbalance weight in aircraft, missiles (stopped in 1980).
- 4. Radiation shield in medical radiotherapy.
- 5. Containers for the transport of radioactive materials.

**b. Military applications:**

- 1. Ammunition and projectile to penetrate armor plate. (In both Gulf Wars, 1991 and 2003, in Bosnia 1995 and Kosovo 1999). Depleted uranium used by USA forces in recent wars.
- 2. Armor plate for military vehicles, such as tanks.

Gulf war	Balkan	Iraq war
286 tons	11 tons	75 tons



**Pathways of exposure to DU or Uranium:**

**1. Inhalation:**

- a. The use of DU munitions in conflict.
- b. When DU in the environment is re-suspended in the atmosphere by wind or disturbance.
- c. Accidental inhalation from; fire in DU storage facility, an aircraft crash or the decontamination of vehicles from within or near conflict areas.

**2. Ingestion:**

- a. drinking water or food contaminated with DU.
- b. Ingestion of soil contaminated with DU by children.

**3. Dermal contact:**

- a. It is unimportant since little DU will pass across the skin into the blood.
- b. DU could enter the circulatory system through open wounds or from embedded depleted uranium fragments.

**Body retention:**

1. More than 95% of uranium entering the body is not absorbed, and eliminated via the feces.
2. 67% of uranium absorbed filtered by kidney and excreted in the urine in 24h.
3. 0.2 of uranium in food and 0.02 of uranium in water is absorbed by the gastrointestinal tract.

**Health effects:**

1. Chemical and radiological toxicity with kidney and lung.

2. Failure in the function of kidney depending on the level of exposure. Some of these failures may be temporary.
3. Inhaled of Insoluble uranium particles (1-10 $\mu$ m size) retained in the lung and lead to lung cancer if a high radiation dose results over a long period.
4. Direct contact of DU with skin, not produce erythematic.
5. Follow-up studies of veterans with embedded fragments in the tissue shown detectable levels of DU in the urine.

### **Biological effects of radiation**

Early human evidence of harmful effects as a result of exposure to radiation existed in the 1920's, based upon the experience of early radiologists, miners exposed to airborne radioactivity underground, persons working in the radium industry, and other special occupational groups.

Body cells come in two types: **Germ cells** (spermatozoa and ova) and **Somatic cells** everywhere else. Each cell contains a complete set of chromosomes; DNA carries the blueprints for life. In human the somatic cells contain 23 pairs of chromosomes (46 chromosomes). This number varies with different species of animals.

### **Effects of radiation on cells:**

Biological effect begins with the ionization of atoms; Ionizing radiation absorbed by human tissue removes electrons from the atoms that make up molecules of the tissue. The bond is broken and thus, the molecule falls apart. The following are possible effects of radiation on cells:

1. Cells are undamaged by the dose.
2. Cells are damaged, repair the damage and operate normally.
3. Cells are damaged, repair the damage and operate abnormally.
4. Cells die as a result of the damage.

Cells are not equally sensitive to radiation damage. Cells which divide rapidly tend to show effects at lower doses of radiation.

### **Cellular damage (mechanisms of radiation damage)**

Radiation absorbed in the cell impact the critical target (DNA). DNA damage causes the cell death, mutation, and carcinogenesis. These mechanisms happen via one of two scenarios.

#### **1. Direct Effect:**

In the first scenario, radiation impacts DNA directly and ionizing it, this visualized as a “direct hit”. It is uncommon occurrence because the small diameter of DNA helix (2nm). It is estimated that the radiation must produce ionization within a few nanometers of the DNA molecule in order for this action to occur.

#### **2. Indirect Action:**

In the second scenario, the radiation interacts with non-critical target usually water (80% of human body). This produces free radicals, which then attack the DNA. Radicals are the atoms that have unpaired electron and thus are highly reactive. When radiation interacts with water; it break the bonds hold the water molecule together, producing hydrogen (H<sup>\*</sup>) and hydroxyls (OH<sup>\*</sup>) .

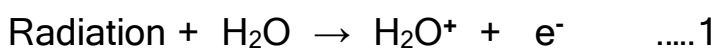

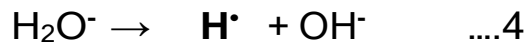
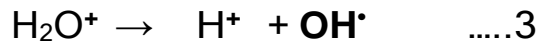

The ions ( $H^+$  &  $OH^-$ ) are no consequence, while ( $\mathbf{OH}^\bullet$ ) will combine with the organic molecule (R-H) to form water, which not harm the cells, or combine to form toxic substances, hydrogen peroxide ( $H_2O_2$ ), which destruct the cells.

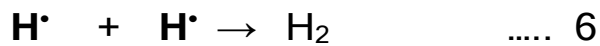

Q: why Damage from indirect action is much more common than damage from direct action.

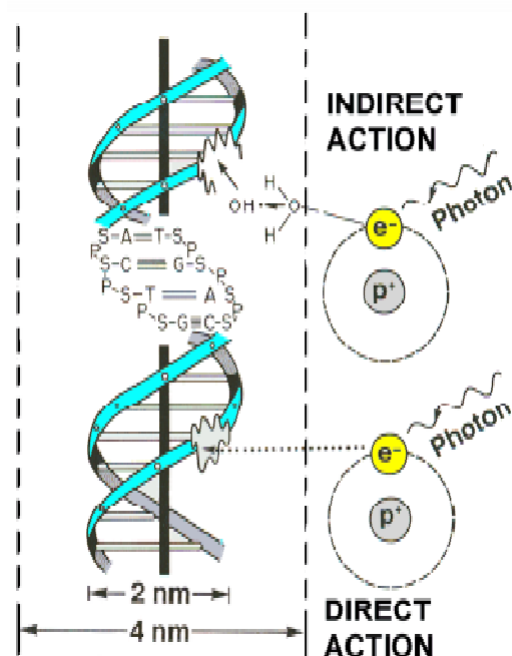

### Sensitivity to Radiation

**Cellular Sensitivity:**

Not all living cells are equally sensitive to radiation. Dividing cells are more sensitive than other, because they require DNA information in order for the cell's offspring to survive. Thus we can list human cells from most sensitive to least sensitive as:

1. White blood and Blood Forming Cells.
2. Gastrointestinal (GI) Cells.
3. Nerve and Muscle Cells.

**Organ Sensitivity:**

The sensitivity of the organs correlates with the sensitivity of their cells. Since the blood forming cells were one of the most sensitive cells, the blood forming organs are one of the most sensitive organs to radiation. Thus we can list human organ from most sensitive to least sensitive as:

1. Blood forming organs.
2. Reproductive and gastrointestinal tract organs.
3. Skin.
4. Muscle and brain.

**Whole Body Sensitivity Factors:**

Whole body sensitivity depends upon the most sensitive organs which depend upon the most sensitive cells. The biological effects of the whole body from exposure to radiation will depend upon several factors:

1. Total dose.

2. Type of cell.
3. Type of radiation.
4. Age of individual.
6. Part of body exposed.
7. General state of health.
8. Tissue volume exposed.
9. Time interval over which dose is received.

## Risks of radiation at Health Effects

All people are constantly (**chronically exposed**) to background (radiation in the environment from natural or man-made sources). Many people receive also additional exposures (**acute exposures**) like the radiation from the work we do; care is taken to protect against biological damage to cells and DNA (genetic material).

There are two types of exposure according to the amount of the dose:

### **1. Acute exposure ( high dose):**

It is the exposure to a large single dose of radiation (10 rad or greater to the whole body), or a series of doses for a short period of time (few days), high levels of acute radiation exposure can result in death within a few hours, days or weeks. It results from accidental exposures or from special medical procedures (radiation therapy).

**Q:** why only 50% of population would die within 30 days after receiving a dose to the whole body within few minutes to a few hours?

**Answer:** Because radiation affects different people in different ways. And this would vary depending on the health of the individual before the exposure and the medical care received after the exposure.

### **2. Chronic exposure (low dose):**

It is the continuous or discontinuous exposure to low levels of radiation over a long period of time. It is the type of dose received as occupational exposure. Its effects include genetic effects, cancer, benign tumors, cataracts, skin changes,

others. Low doses (less than 100mSv) effects appear over long periods of time (5-20 years) after exposure.

**Q:** can the body repair the damage after exposure to chronic dose?

**Answer:** yes the body can repair itself because a smaller percentage of the cells need repair at any given time. The body also has time to replace dead or non-functioning cells with healthy cells.

### **Radiation dose limits:**

Government agencies established regulations that set limits for exposure to radiation and radioactive material. These limits are designed to protect individual workers, the public, and the environment, and are set at “acceptable” levels of risk similar to those for industrial activities (e.g., chemical, mining, and transportation).

#### **1. Occupational dose limit:**

a. The effective dose should not exceed (50mSv/y) in any single year or (20mSv/y) over five consecutive years.

1. Annual Dose limit = 20 mSv/y.
2. Weekly Dose limit =  $20/50 = 0.4$  mSv/w.
3. Daily Dose limit =  $0.4/5 = 0.08$  mSv/d = 80  $\mu$ Sv/d.
4. Hourly Dose limit =  $80/8 = 10$   $\mu$ Sv/h.

b. The equivalent dose to the extremities (hands and feet) or the skin should not exceed (500mSv/year).



**2. Public dose limit:**

1. The effective dose should not exceed (1mSv/year) in a year or (5mSv) in a single year [provided that the average dose over five consecutive years does not exceed 1mSv/year].
2. The equivalent dose to the skin should not exceed (50mSv/year).

**Biological Effects of High Dose exposure:**

Every people exposed to acute whole body dose, and not death the following effects might be observed on them.

1. Main effects as in the table below.

Dose (Rad)	Effect Observed
15 - 25	Blood count changes in a group of people
50	Blood count changes in an individual
100	Vomiting (threshold)
150	Death (threshold)
320 - 360	LD 50/60 with minimal care
480 - 540	LD 50/60 with supportive medical care
1,100	LD 50/60 with intensive medical care

- a. The threshold values mean the doses at which the effect is first observed.
- b. LD 50/60 is the lethal dose at which 50% of those exposed will die within 60 days.

2. Skin Burns: include erythema reddening, peeling.
3. Hair loss.
4. Sterility: temporary or permanent in males, depending upon the dose. In females, it is usually permanent, but it requires a higher dose (400 rad).
5. Cataracts (a clouding of the lens of the eye).

**Biological Effects of low Doses Exposure:**

1. Genetic: Suffered by the offspring of the individual exposed involves the mutation of sperm or egg cells.
2. Somatic (Carcinogenic Effect): suffered by the individual exposed (typically cancer) which includes:
  - A. Lung cancer: uranium miners.
  - B. Bone cancer: radium dial painters.
  - C. Thyroid cancer: therapy patients.
  - D. Breast cancer: therapy patients.
  - E. Skin cancer: radiologists.
  - F. Leukemia: bomb survivors, radiologists, therapy patients.
3. In-Utero: Involves the production of malformations while the baby is still in the fetal stage of development such as:
  - a. Intrauterine Death.
  - b. Developmental Abnormalities.
  - c. Childhood Cancers.

**External and internal radiation exposure:**

**External exposure:**

It's occurring when the body is exposed to a penetrating radiation from an external source. During exposure this radiation can be absorbed by the body or it can pass completely through, similar to a chest x-ray. Exposure to a radiation does not cause an individual to become radioactive; the radiation exposure ceases as soon as the individual leaves the radiation field.

All ionizing sources produce an external radiation field. Some fields are so small they pose no external radiation risk at all. Examples low and moderate energy beta radiation emitters: H-3, C-14, Ni-63, P-33, and S-35.

Other sources of ionizing radiation produce much higher energy external radiation fields, and care must be taken to shield the source and to monitor exposure while working near these sources. Examples include:

- Am-241/Be neutron sources
- P-32 beta sources
- Cs-137 gamma sources
- Co-60 gamma sources
- X-ray machines (only when the machine is energized).

### **Internal exposure:**

its involve **contamination** with radioactive material. Contamination means that radioactive material in the form of gases, liquids, or solids are released into the environment and contaminate people externally (such as on the skin), or internally (such as by ingestion), or both. This can be the result of uptake of radioactive material by body cells, tissues, and target organs such as bone, liver, thyroid, or kidney. In general, radioactive materials are distributed throughout the body based upon their chemical properties. For example, radioiodine, such as  $^{125}\text{I}$ , is concentrated in the thyroid gland of the body.

**All radioisotopes are hazardous if inhaled or ingested.** This includes low energy isotopes such as  $^3\text{H}$  and  $^{14}\text{C}$ . Frequent monitoring for contamination is

necessary when working with any unsealed isotopes, and periodic leak tests are conducted for sealed sources (usually every 6 months).

X-ray machines contain no radioactive material, and thus pose no threat of contamination even when energized. When energized, an x-ray machine is a source of external radiation exposure.

## External and Internal Dose Calculation

### Radiation protection principles:

The methods of reducing external radiation dose are:

1. Decrease time of exposure.
2. Increase distance from the source.
3. Increase the amount of shielding present.

### Variation of dose as a function of time (dose and dose time):

The dose received is a linear function to the time of exposure, where:  $D = D \bullet \times t$

D: received dose,       $D \bullet$ : dose rate,      t: exposure time.

**Example:** Estimate the **time** required for a worker to working in 2.5mSv/h, so that he shouldn't exceed the daily limit?

**Solution:**  $D = \text{Daily limit} = 20 / (50 \times 5) = 0.08 \text{mSv}$ ,  $D \bullet = \text{dose rate} = 2.5 \text{mSv/h}$

Thus  $t = D / D \bullet = 0.08 \text{mSv} / 2.5 \text{mSv/h} = 0.032 \text{ h} = 1.92 \text{ min}$ .

**Example:** a person could expect to receive a dose of 25millirems by staying in a 50millirems/hour field for thirty minutes.

**Solution:** Dose = dose rate x time = 50mrem/hr x ½ hour = 25mrem

Note: The dose is equal to the strength of the radiation field while the (dose rate) multiplied by the length of time spent in that field.

**Variation of Dose as a Function of distance:**

Radiation dose decreases with the increasing of the distance square from the source of radiation (Inverse-square law):  $D_2 S_2^2 = D_1 S_1^2$

D<sub>1</sub>: dose rate at distance 1 , D<sub>2</sub>: dose rate at distance 2

S<sub>1</sub>: is distance 1 , S<sub>2</sub> :is distance 2.

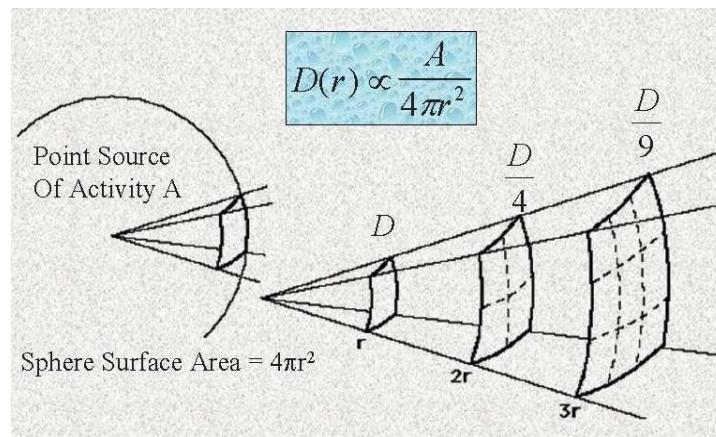

**Example:** The dose rate at 2meters away from a gamma source measures 100mSv/h. What is the dose rate at 4 meters?

Answer:  $D_2 S_2^2 = D_1 S_1^2$

$$D_2 = D_1 \times (S_1^2 / S_2^2) = 100 \times (2^2 / 4^2) = 25 \text{ mSv/h}$$

**Variation of Dose as a Function of Shielding (Narrow Beam Geometry):**

The attenuation of gamma radiation by an absorbing material is described by:

$$D = D_0 e^{(-\mu x)}$$

I<sub>0</sub> : is the original radiation intensity.

I : radiation intensity after traversing a thickness x.

μ :is the linear attenuation coefficient (cm<sup>-1</sup>).

x :is the thickness of attenuating material (cm).

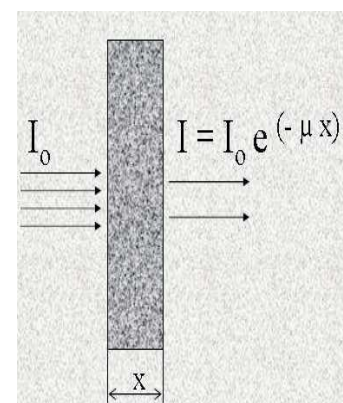

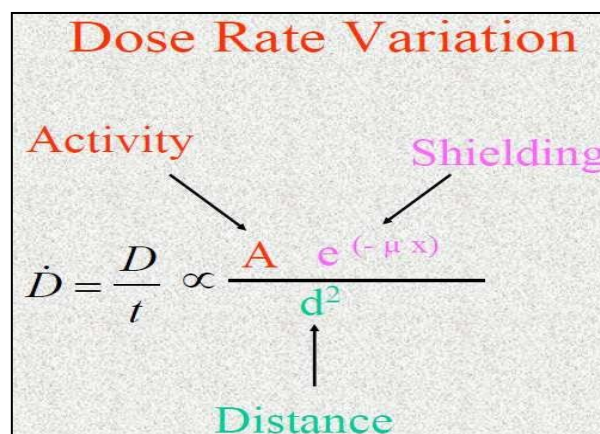
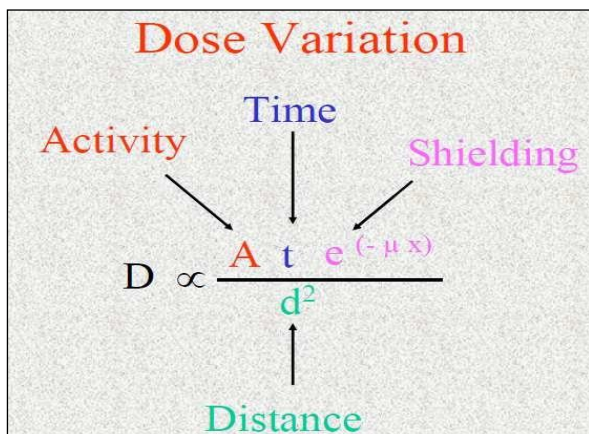

**Estimation of Dose Rate from Gamma Sources:**

The equivalent dose rate from a gamma source is calculated by:

$$D \bullet = \frac{\Gamma \times A}{d^2}$$

Where:

$D \bullet$  :is the equivalent dose rate in  $\mu\text{Sv/h}$ .

$\Gamma$  :is the gamma factor (dose rate constant) in  $\mu\text{Sv}\cdot\text{m}^2/(\text{MBq}\cdot\text{h})$ .

$A$  :is the activity of the source in MBq.

$d$  : is the distance in meters from the source.

**Specific Gamma Dose Rate Constant:**

It is the equivalent dose rate in  $\mu\text{Sv/h}$  at 1meter from 1MBq of the radionuclides in  $\mu\text{Sv}\cdot\text{m}^2/(\text{MBq}\cdot\text{h})$ .

isotope	$\Gamma$ factor
C0-60	0.351
Cs-137	0.086
Ir-192	0.13

**Estimation of Dose Rate from Gamma Sources:**

If  $\Gamma$  is not known for a certain gamma source, the equivalent dose rate is estimated by:

$$D \bullet = \frac{0.14 \times A \times E}{d^2}$$

Where:

D: is the equivalent dose rate in  $\mu\text{Sv/h}$ .

A: is the activity of the source in MBq.

E: is the gamma ray energy in MeV.

d :is the distance in meters from the source.

Example: Calculate the equivalent dose rate at a distance of 5 m from an Ir-192 gamma source which has an activity of 400MBq.

Answer :  $D = \Gamma \times A / d^2 = 0.13 \times 400 / 5^2 = 2.08 \mu\text{Sv/h}$ .

**Estimation of Dose Rate from Beta Sources:**

The equivalent dose rate from a beta source is calculated by:

$$D \bullet = \frac{5 \times A \times E}{d^2}$$

where:

D• :is the equivalent dose rate in  $\mu\text{Sv/h}$ .

A : is the activity of the source in MBq.

E :is the average energy =  $E_{\text{max}}/3$  in MeV.

d : is the distance in meters from the source.

Example: Calculate the equivalent dose rate at a distance of 20cm from a thin unshielded P-32 beta source which has an activity of 20mCi.

Answer:

$$\text{Activity in MBq} = 20 \times 10^{-3} \times 3.7 \times 10^{10} \times 10^{-6} = 740 \text{ MBq}$$

$$E_{\text{avg}} = E_{\text{max}}/3 = 1.71 / 3 = 0.57 \text{ MeV}$$

$$D \bullet = 5 \times 740 \times 0.57 / 0.2^2 = 52700 \mu\text{Sv/h}$$

**Estimation of Dose Rate from Neutron Sources:**

The equivalent dose rate from a neutron source can be calculated by:

$$D \bullet = \frac{0.08 \times C \times N}{d^2}$$

where:

$D \bullet$  : is the equivalent dose rate in  $\mu\text{Sv/h}$ .

N: is the neutron fluence in neutrons/s.

C: the neutron flux to equivalent dose rate conversion factor in  $(\mu\text{Sv/h})/(\text{n/m}^2\text{s})$ .

d : is the distance in meters from the source.

Equivalent dose rate conversion factor in  $(\mu\text{Sv/h})/(\text{n/m}^2\text{s})$  are :

neutron energy	Conversion
1KeV	$3.74 \times 10^{-6}$
10KeV	$3.56 \times 10^{-6}$
100KeV	$2.17 \times 10^{-5}$
500KeV	$9.25 \times 10^{-5}$
1MeV	$1.32 \times 10^{-4}$
5MeV	$1.56 \times 10^{-4}$
10MeV	$1.47 \times 10^{-4}$

**Example:** Calculate the equivalent dose rate at 0.5m from an Am-Be neutron source that emits  $3 \times 10^7 \text{n/s}$ , assuming the average energy of the neutron is 1MeV.

**Answer:** From table C for 1 MeV =  $1.32 \times 10^{-4} (\mu\text{Sv/h})/(\text{n/m}^2\text{s})$ .

$$D \bullet = (0.08 \times 1.32 \times 10^{-4} \times 3 \times 10^7) / 0.5^2 = 1.27 \times 10^3 \mu\text{Sv/h}.$$

**Estimation of Dose Rate from Alpha Sources:**

- Alpha particles do not present an external radiation hazard.
- Range of 8 MeV Alpha is 0.07 mm of skin.
- External dose calculations are generally not required.



**Elimination of radionuclides from the body:**

The most important factors that determining the hazard of a radioisotope inside the body are:

- 1) The amount of radioactive material deposited in the body.
- 2) The type and energy of the radiations emitted.
- 3) The time for which it effectiveness in the body. Time depends on; the radioactive half-life ( $T_r$ ) and the biological half-life ( $T_b$ ).

**Physical (Radioactive )Half-life ( $T_r$ ):**

The time required to reduce the radioactivity of a source to half of its original value due to radioactive decay.  $T_r = 0.693/\lambda$

**Biological Half-life ( $T_b$ ):**

The time required to reduce the amount of a radioactive isotope or drug in an organ or the body to a half of its original value due to biological elimination.

$$T_b = 0.693/\lambda$$

**Effective Half-life ( $T_{eff}$ ):**

The time required to reduce the radioactivity of an internal organ to half of its original value due to both biological elimination and radioactive decay.

$$\frac{1}{T_{eff}} = \frac{1}{T_p} + \frac{1}{T_b} \quad , \quad T_{eff} = \frac{T_p \times T_b}{T_p + T_b}$$

Isotope	Half-lives in days		
	$T_{\text{Physical}}$	$T_{\text{Biological}}$	$T_{\text{Effective}}$
$^3\text{H}$	$4.5 \times 10^3$	12	12
$^{14}\text{C}$	$2.1 \times 10^6$	40	40
$^{22}\text{Na}$	850	11	11
$^{32}\text{P}$	14.3	1155	14.1
$^{35}\text{S}$	87.4	90	44.3
$^{36}\text{Cl}$	$1.1 \times 10^8$	29	29
$^{45}\text{Ca}$	165	$1.8 \times 10^4$	164
$^{59}\text{Fe}$	45	600	42
$^{60}\text{Co}$	$1.93 \times 10^3$	10	10
$^{65}\text{Zn}$	244	933	193
$^{86}\text{Rb}$	18.8	45	13
$^{90}\text{Sr}$	$1.1 \times 10^4$	$1.8 \times 10^4$	$6.8 \times 10^3$
$^{99\text{m}}\text{Tc}$	0.25	1	0.20
$^{123}\text{I}$	0.54	138	0.54
$^{131}\text{I}$	8	138	7.6
$^{137}\text{Cs}$	$1.1 \times 10^4$	70	70
$^{140}\text{Ba}$	12.8	65	10.7
$^{198}\text{Au}$	2.7	280	2.7
$^{210}\text{Po}$	138	60	42
$^{226}\text{Ra}$	$5.8 \times 10^5$	$1.6 \times 10^4$	$1.5 \times 10^4$
$^{235}\text{U}$	$2.6 \times 10^{11}$	15	15
$^{239}\text{Pu}$	$8.8 \times 10^6$	$7.3 \times 10^4$	$7.2 \times 10^4$

### **Properties of some Isotopes:**

1. Tritium ( $^3\text{H}$ ): has a long physical half-life but clears from the body quickly, lessening the exposure.
2. Phosphorous ( $^{32}\text{P}$ ): is used for some kinds of bone scans. It held in the bones, leading to a long biological half-life, but its physical half-life is short enough to minimize exposure.

3. Strontium ( $^{90}\text{Sr}$ ): is very bad news in the environment. It mimics calcium and therefore gets trapped in bone. This gives it a long biological half-life to go with its long physical half-life, making it doubly dangerous.
4. Technetium ( $^{99\text{m}}\text{Tc}$ ): is one of the favorites for diagnostic scans because of short physical and biological half-lives. It clears from the body very quickly after the imaging procedures.

Problem 1:

( $\text{I}^{131}$ ) sodium iodide has a  $t_{\text{biol}}$  of 24 d. What is  $t_{\text{eff}}$  ?

$$1/t_{\text{eff}} = 1/t_{\text{phys}} + 1/t_{\text{biol}} = 1/8 + 1/24 = 1/6 \quad , \quad \text{so} \quad t_{\text{eff}} = 6 \text{ d.}$$

Problem 2:

A ( $\text{Tc}^{99\text{m}}$ ) compound has a  $t_{\text{eff}} = 1$  hr. What is  $t_{\text{biol}}$  ?

$$1/t_{\text{biol}} = 1/t_{\text{eff}} - 1/t_{\text{phys}} = 1/1 - 1/6 = 5/6 \quad , \quad \text{so} \quad t_{\text{biol}} = 1.2$$

Problem 3:

A radiopharmaceutical has a biological half-life of 4.00hr and an effective half-life of 3.075 hr. What isotope was used?

$$1/t_{\text{phys}} = 1/t_{\text{eff}} - 1/t_{\text{biol}} = 1/3.075 - 1/4.00 = 0.0752033$$

Therefore  $t_{\text{phys}} = 13.3\text{hr}$  and the radioisotope is  $\text{I}^{123}$

Problem 4:

The physical half-life for I-131 is 8 days and its biological half-life in the thyroid is 180 days. Find its effective half-life and the effective decay constant?

Answer:

$$T_{\text{eff}} = (180 \times 8) / (180 + 8) = 7.7 \text{ days} \quad , \quad \lambda_{\text{eff}} = 0.693/7.7 = 0.09 \text{ day}^{-1}$$

Problem 5:

Calculate the original activity of a radioisotope in a urine sample, if the activity of the sample is 666KBq after 6 days of the accident, and the effective decay constant is  $\lambda_{\text{eff}} = 0.1 \text{ day}^{-1}$ .

Answer:

$$A_t = A_o e^{-\lambda_{\text{eff}} t}$$

$$A_o = 666/e^{-(0.1 \times 6)} = 666/ e^{-0.6} = 666/0.5488 = 1214\text{KBq}$$

Problem 6:

What is the effective half-life of a  $\text{Po}^{210}$  in the body having  $t_{1/2} = 138\text{day}$  and  $t_{\text{biol}} = 40\text{day}$ ?

$$1/t_{\text{eff}} = 1/t_{1/2} + 1/t_{\text{biol}} = 1/138 + 1/40 = 138 \times 40 / (138 + 40) = 31 \text{ days}$$

What is the difference between intake and uptake?

Intake is what you take in, uptake is what you keep. Think of a smoker. With each suck on his cigarette, he drags all kinds of crud into his lungs. That's the intake. Fortunately most of this is exhaled, and only a part of the intake remains behind in the lungs as a deposit. That's the uptake by the lung.

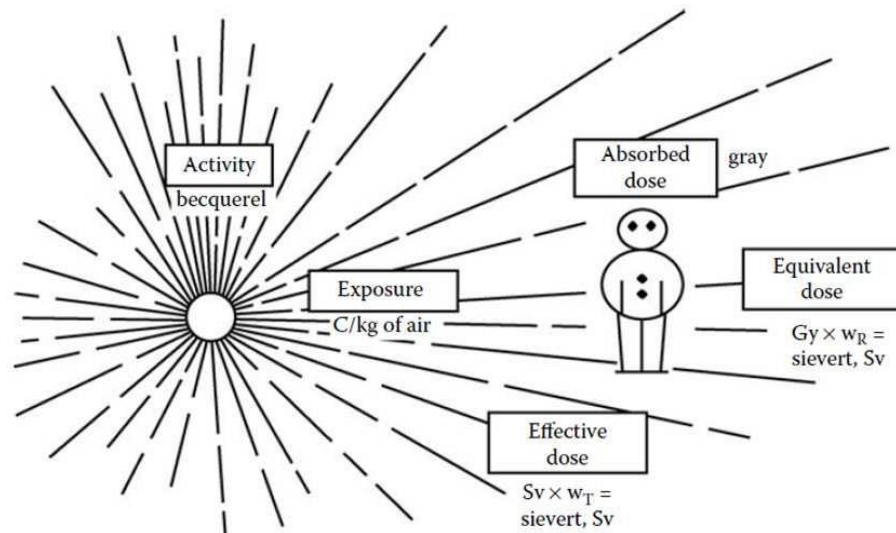

**Exposure (X)**

It is the sum of all the electrical charges (Q) of one sign produced by x- or gamma in a given mass (m) of dry air, and expressed by:

$$X = Q/m$$

Its units are (C/kg), and roentgen (R),  $1R = 2.58 \times 10^{-4}$  C/kg of dry air. Exposure applies only to x- or gamma rays under 3 MeV of energy.  $1C/kg = 3876$  roentgens.

The intensity of x- or gamma radiation field is defined as the number of photons passing through a cross section of  $1cm^2$  at some distance from the source. This is referred to flux, Intensity is measured in exposure rate at some distance from the source, and expressed in (mR/h) or ( $\mu$ Sv/h).

**Absorbed Dose (D)**

It is the radiation energy (E) transferred to a unit mass (m) of any material, and expressed by:

$$D = E/m$$

Its unit is gray (Gy), which is equal to the absorption of one joule of energy per kg of any material including the body of a patient or technologist. Its special unit is rad (radiation absorbed dose), which defined as  $1 \text{ rad} = 0.01J/kg$  of material.

To measure the absorbed dose by radiation workers, calibrated dosimeters are used. Such as film badges, (TLD) badges to monitor body dose, and TLD ring dosimeters to monitor hand dose.

### **Equivalent Dose ( $H_{T,R}$ ):**

It's introduced to account for the differences in the ionizing quality of the various types of radiations. It expressed in (Sv). It is the product of the average absorbed dose ( $D_{T,R}$ ) received by tissue(T) from radiation (R) times the radiation weighting factor ( $w_R$ ):

$$H_{T,R} = D_{T,R} \times w_R$$

Example: calculate the equivalent dose for a person accidentally inhales some radioactive dust. The absorbed dose to the respiratory tract is 50mGy from alpha particles, 30mGy from beta radiation, and 20mGy from gamma rays.

Answer:

The total absorbed dose = 50 + 30 + 20 = 100mGy,

The equivalent dose = 50x20) + (30x1) + (20x1) = 1050mSv

<b>Radiation</b>	<b><math>w_R</math></b>
Beta, gamma, x-rays	1
Neutrons, <10 keV	5
>10-100 keV	10
>100 keV-2 MeV	20
>2 MeV-20 MeV	10
>20 MeV	5
Protons, >2 MeV	2
Alpha, heavy ions	20

**Effective Dose (E):**

Due to the fact that organs and tissues have different sensitivities to radiation, the effective dose (E) was introduced and is defined as the sum of the products of the equivalent doses ( $H_{T,R}$ ) received by an organ times the tissue weighting factors

$$(w_T): \quad E = \sum(H_{T,R} \times w_T)$$

Effective doses are expressed in (Sv). NRC list a table of recommended tissue-weighting factors ( $w_T$ ).

Example: As shown in Table, an effective dose of 10mSv to the bone marrow has 12 times the risk of stochastic effect than the same dose to the skin (0.12 vs. 0.01).

<b>Tissue</b>	<b>Weighting Factors (<math>w_T</math>)</b>
Gonads	0.20
Bone marrow	0.12
Colon	0.12
Lung	0.12
Stomach	0.12
Bladder	0.05
Breast	0.05
Liver	0.05
Esophagus	0.05
Thyroid	0.05
Skin	0.01
Bone surface	0.01
Remainder	0.05
<b>Total Body</b>	<b>1</b>

**Relative biological effectiveness (RBE):**

It is used to account for the sensitivities of different biological systems to alpha, beta, electron beams, neutron fluxes of various energies and, of course, x- and gamma rays.

RBE is the ratio of the dose of 250kVP (kilovolt-peak) x-rays, which produces some effect, to the dose of another radiation that produces the same effect in the same degree.

The RBE for radiation of type  $R$  on a tissue of type  $T$  is defined as the ratio:

$$\text{RBE} = \frac{D_X}{D_R}$$

$D_X$  is a reference absorbed dose of radiation of a standard type  $X$ , and  $D_R$  is the absorbed dose of radiation of type  $R$  that causes the same amount of biological damage.

**Equilibrium**

If a parent radionuclide (p) decays to a daughter radionuclide (d), which in turn decays, then the rate of growth of radionuclide (d) becomes:

$$\frac{dN_d}{dt} = \lambda_p N_p - \lambda_d N_d \quad \text{---1}$$

$\lambda_p N_p$  is the growth rate of the daughter from the parent, and  $\lambda_d N_d$  is the decay rate of the daughter. By integration the Eq. above we get:

$$(A_d)_t = \lambda_d N_d = \frac{\lambda_d (A_p)_0}{\lambda_d - \lambda_p} (e^{-\lambda_p t} - e^{-\lambda_d t}) \quad \text{---2}$$

Equation (2) gives the net activity of radionuclide (d) at time (t) due to the growth from the decay of radionuclide (p). If there is an initial activity  $(A_d)_0$  of radionuclide (d), then the term  $(A_d)_0 e^{-\lambda_d t}$  has to be added to Eq. (2). Thus



$$(A_d)_t = \lambda_d N_d = \frac{\lambda_d (A_p)_0}{\lambda_d - \lambda_p} (e^{-\lambda_p t} - e^{-\lambda_d t}) + (A_d)_0 e^{-\lambda_d t} \quad \text{---3}$$

Equilibrium occurs when a fixed ratio exists between the activity of the parent and daughters. When equilibrium exists, the activity of the daughters is decreasing according to the half-life of the parent. There are two types of equilibrium; in addition to (no equilibrium):

1. Secular equilibrium.
2. Transient equilibrium.

### Secular Equilibrium:

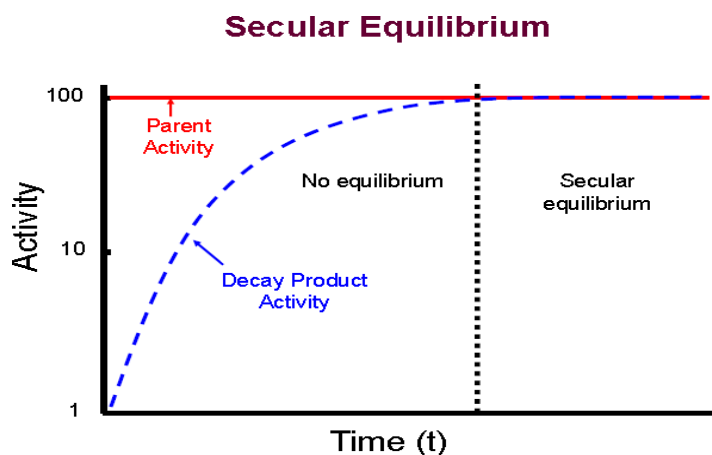

1. It is possible if the parent's half-life is much greater than that of the daughter decay product. ( $t_{1/2 P} \gg t_{1/2 d}$ ), ( $\lambda_d \gg \lambda_p$ ), we can neglect  $\lambda_p$  compared to  $\lambda_d$ . Then Eq. 3 reduces to:

$$(A_d)_t = (A_p)_t \quad \text{---4}$$

2. When (S.E.) achieved, the activity of the daughter equals that of the parent. (A Daughter = A parent).
3. Starting with nothing but the parent, the time to reach secular equilibrium is roughly five to ten half-lives of the daughter. S.E. time = (5-10)  $t_{1/2}$  of the daughter.

Example: if one curie of pure radium-226 is placed in a sealed container, the activity of radon-222 will increase until it also reached one curie. This would take 20 to 30 days given the 3.8 day half-life of Rn-222.

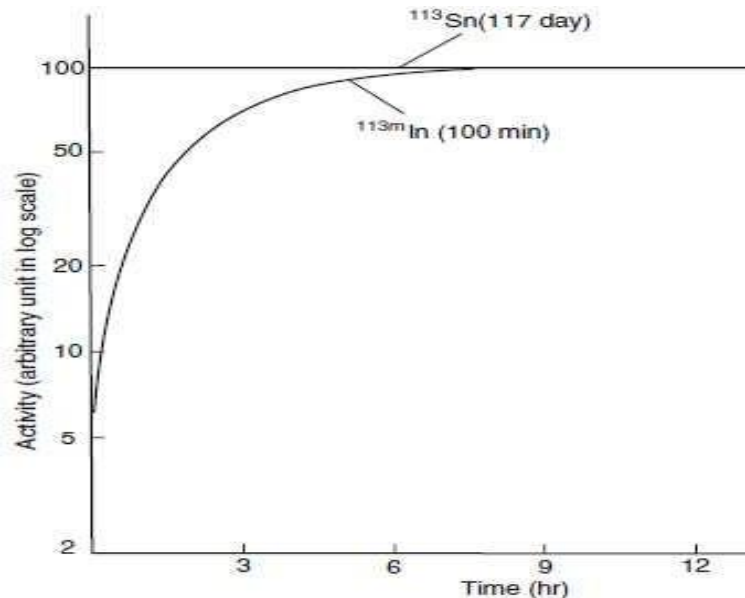

Secular equilibrium between Sn-113( $t_{1/2}$  = 117days) and In-113m( $t_{1/2}$  =100min)

Example:

Germanium-68 has a half-life of 280 days and decays to  $^{68}\text{Ga}$ , whose half-life is 68min. The activity of a pure sample of  $^{68}\text{Ge}$  is calibrated to be 450mCi (16.7GBq) at noon on Tuesday. Calculate the activity of  $^{68}\text{Ga}$  at midnight on Tuesday and at 5:00 p.m. on Wednesday.

Answer: The time from Tuesday noon to midnight Tuesday is 12h and the time from Tuesday noon until 5:00 p.m. Wednesday is 29h. Since the half-lives of  $^{68}\text{Ge}$  and  $^{68}\text{Ga}$  differ by a factor of about 5,800, a secular equilibrium is established between the two nuclides within 12h ( $\sim 11$  half-lives of  $^{68}\text{Ga}$ ) and 29h. The decay of  $^{68}\text{Ge}$  in a 29-h period is negligible, and therefore the activity of  $^{68}\text{Ge}$  at both midnight Tuesday and 5:00p.m. on Wednesday would be approximately 450mCi (16.7GBq). Then, according to Eq. 4, the activity of  $^{68}\text{Ga}$  at these times would also be 450mCi (16.7GBq).

## 2. Transient Equilibrium:

1. Transient equilibrium established if the parent nuclide's half-life is not "much" greater than that of the daughter  $(t_{1/2})_d < (t_{1/2})_p$ ,  $\lambda_d > \lambda_p$ , then  $e^{-\lambda_d t}$  (3) is negligible compared to  $e^{-\lambda_p t}$  in equation when  $t$  is sufficiently long, and the equation become:

$$(A_d)_t = \frac{\lambda_d(A_p)_0}{\lambda_d - \lambda_p} e^{-\lambda_p t} = \frac{\lambda_d(A_p)_t}{\lambda_d - \lambda_p} \quad \underline{\quad 5}$$

2. The time to reach transient equilibrium is five to ten half-lives of the daughter.
3. When transient equilibrium is achieved:
- The daughter activity exceeds that of the parent.
  - The daughter activity decreases according to the half-life of the parent.

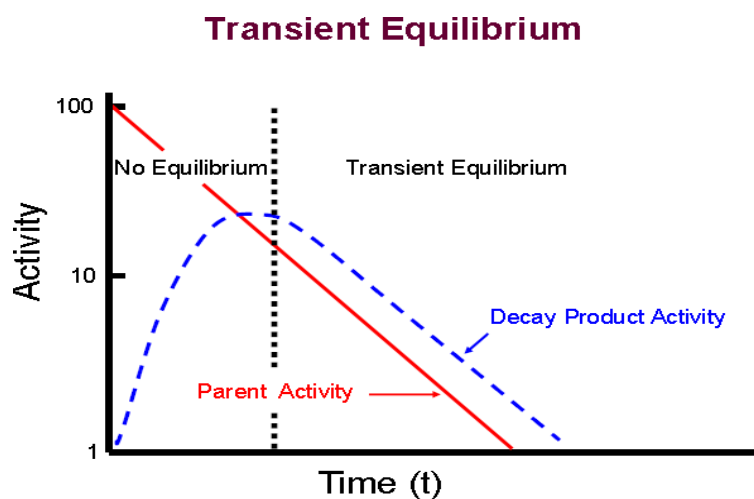

Problem:

Yttrium-87 ( $t_{1/2} = 80$  h) decays to  $^{87m}\text{Sr}$  ( $t_{1/2} = 2.83$  h). The activity of a pure sample of  $^{87}\text{Y}$  is calibrated at noon on Wednesday and measured to be 300mCi (11.1GBq). Calculate the activity of  $^{87m}\text{Sr}$  at 6:00 p.m. on Wednesday and at 6:00 p.m. on Thursday.

Answer:

$$\lambda_p = \frac{0.693}{80} = 0.0087 \text{ hr}^{-1}$$

$$\lambda_d = \frac{0.693}{2.83} = 0.2449 \text{ hr}^{-1}$$

$$\frac{\lambda_d}{\lambda_d - \lambda_p} = \frac{0.2449}{0.2449 - 0.0087} = 1.0368$$

$$(A_p)_0 = 300 \text{ mCi}$$

$$t = 6 \text{ h (from noon to 6 p.m. Wednesday)}$$

$$e^{-\lambda_p t} = e^{-0.0087 \times 6} = 0.9491$$

$$e^{-\lambda_d t} = e^{-0.2449 \times 6} = 0.2301$$

$$(A_d)_t = ?$$

Using the above values in Eq. (2.10), the activity of  $^{87\text{m}}\text{Sr}$  at 6:00 p.m. on Wednesday can be calculated as

$$(A_d)_t = 1.0368 \times 300 \times (0.9491 - 0.2301) = 223.6 \text{ mCi (8.27 GBq)}$$

For the activity of  $^{87\text{m}}\text{Sr}$  at 6:00 p.m. on Thursday, we assume a transient equilibrium between  $^{87}\text{Y}$  and  $^{87\text{m}}\text{Sr}$  because the half-lives of the parent and daughter nuclides differ by a factor of 28, and more than ten half-lives (i.e., 30 h) of the daughter nuclide have elapsed between noon Wednesday and 6:00 p.m. on Thursday. Using Eq. (2.12), we have

$$t = 30 \text{ h}$$

$$(A_p)_t = 300 \times e^{-0.0087 \times 30} = 231.1 \text{ mCi}$$

$$(A_d)_t = 1.0368 \times 231.1 = 239.6 \text{ mCi}$$

Therefore, the activity of  $^{87\text{m}}\text{Sr}$  at 6:00 p.m. on Thursday is 239.6 mCi (8.87 GBq).

A typical example of transient equilibrium is  $^{99\text{m}}\text{Mo}$  ( $t_{1/2} = 66 \text{ h}$ ) decaying to  $^{99\text{m}}\text{Tc}$  ( $t_{1/2} = 6.0 \text{ h}$ ). The  $^{99\text{m}}\text{Tc}$  activity reaches a maximum in about 23h, i.e., about four half-lives of  $^{99\text{m}}\text{Tc}$ , followed by the equilibrium. Figure above showed a Plot of  $^{99\text{m}}\text{Mo}$  and  $^{99\text{m}}\text{Tc}$  activities versus time. The activity of the daughter  $^{99\text{m}}\text{Tc}$  is less than that of the parent  $^{99\text{m}}\text{Mo}$ , because only 87% of  $^{99\text{m}}\text{Mo}$  decays to  $^{99\text{m}}\text{Tc}$ . If 100% of the parent were to decay to the daughter, then the daughter activity would be higher than the parent activity after reaching equilibrium.

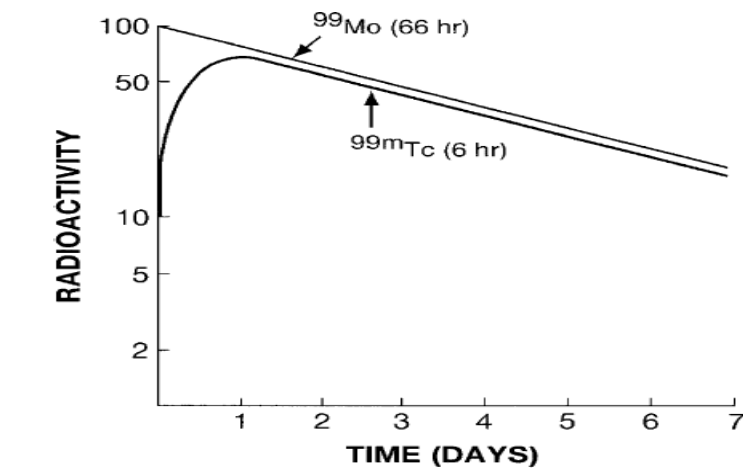

**No Equilibrium**

- If the parent's half-life is shorter than that of the daughter, equilibrium cannot be achieved.
- The daughter activity increases from zero, reaches a maximum, and decreases at a rate primarily determined by its own half-life.
- There is no increase in the total activity with time, the activity will only decrease.

**No Equilibrium**

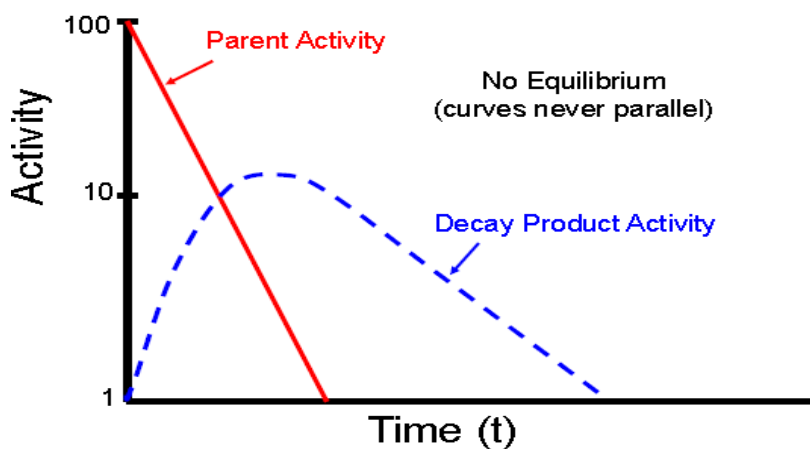

## Radiation Detectors

Humans do not possess any sense organs that can detect ionizing radiation. So, they rely completely on instruments for the detection and measurement of radiation. Example of the Instruments used in health physics are:

1. instruments measure particles:
  - a. Geiger-Muller counters.
  - b. Scintillation counter.
2. instruments measure accumulated doses:
  - a. Film badges.
  - b. Pocket dosimeters.
  - c. Thermoluminescent dosimeters.
3. Instruments measure dose and dose rate:
  - a. ionization-chamber types.

Some physical and chemical radiation effects are listed in table below:

Effect	Type of instrument	detector
Electrical	1. Ionization chamber	Gas
	2. Proportional counter	Gas
	3. Geiger counter	Gas
	4. Solid state detector	Semiconductor
Chemical	1. Photographic emulsion	Photographic emulsion
	2. Chemical dosimeter	Solid or liquid
Light	1. Scintillation counter	Crystal or liquid
	2. Cerenkov counter	Crystal or liquid
TLD	(TLD)	Crystal

### Scintillation detectors:

Scintillation detector is a transducer that changes the kinetic energy of ionizing radiation into light, which viewed electronically by photomultiplier tubes whose output pulses amplified, sorted by size, and counted. Scintillation counters

are used to count gamma and low-energy beta particles. NaI(Tl) detector coupled to a photomultiplier tube is used for gamma measurement.

Gamma photons, passing through the crystal, interact with the atoms of the crystal. The primary ionizing particles resulting from the gamma interactions dissipate their kinetic energy by exciting and ionizing the atoms in the crystal. The excited atoms return to the ground state by the emission of light. These light pulses striking the photocathode of the photomultiplier tube, cause electrons to be ejected from the cathode. These electrons are accelerated to a second electrode, called a dynode, whose potential is about 100-V positive with respect to the photocathode. Each electron that strikes the dynode causes several other electrons to be ejected from the dynode, thereby “multiplying” the original photocurrent. This current pulse, whose magnitude is proportional to the energy of the primary ionizing particle, can be amplified and counted.

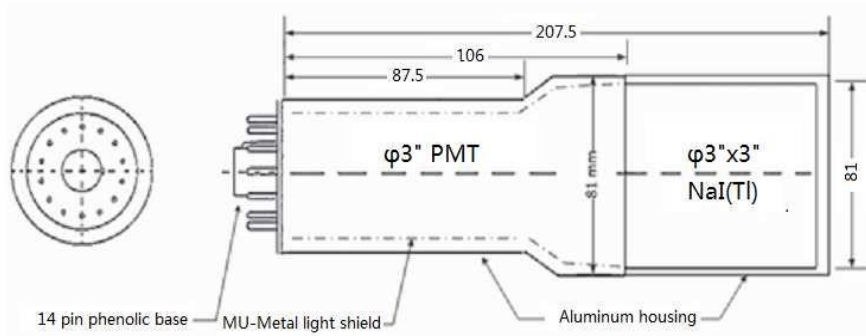

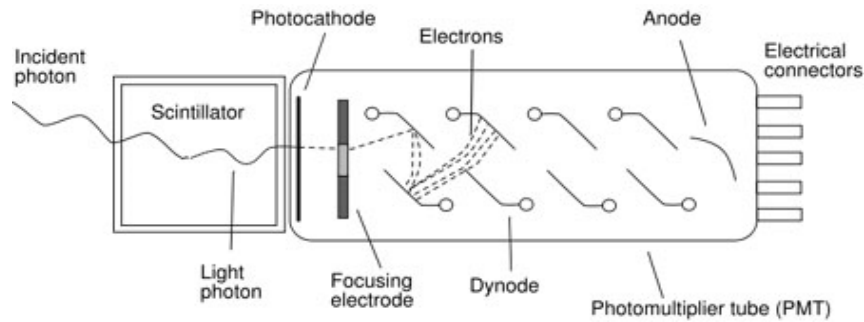

**Nuclear Spectroscopy:**

Nuclear spectroscopy is the analysis of radioisotopes by measuring their energy distribution. A spectrometer is an instrument that separates the output pulses from a detector according to size which is proportional to the energy of the detected radiation. It is useful in identifying unknown radioisotopes and in counting one isotope in the presence of others. It is available in two types:

**a. Single-channel analyzer:**

It consists of a detector, linear amplifier, pulse-height selector, and scaler, its use to discriminate between a desired radiation and noise.

**a. Multichannel analyzer (MCA):**

Has analog-to-digital converter to sort all the output pulses according to height. It also has a computer and visually displays the spectrum on screenmonitor.

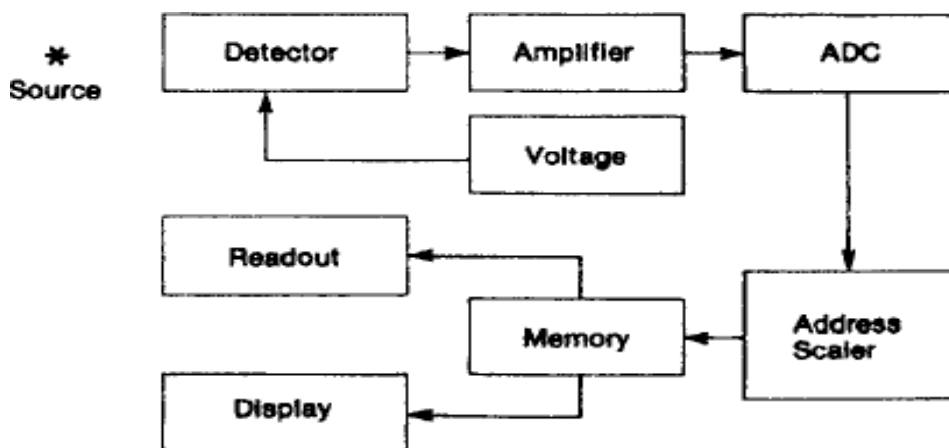



**Semiconductor Detector:**

Germanium and silicon crystals are the commonly semiconductor used as sensitive volume. A semiconductor detector acts as a solid-state ionization chamber. The ionizing particle (beta, alpha particle, etc.) interacts with atoms in the sensitive volume of the detector to produce electrons by ionization.

The collection of these ions leads to an output pulse. In contrast to the high ionization energy of 30–35 eV for counter gases, only 3.5 eV is required to produce an ionizing event in a semiconductor detector (silicon). Therefore, the charge formed by the ionizing particle in semiconductor (silicon) detector is ten times the charge formed in the gas detector by the same particle. This leads to a high resolution power and accurate determination of the ionizing particles energy.

**Types :**

- a. Silicon detectors: used for detecting alpha and protons.
- b. High -purity germanium detector: used for detecting beta and gamma

**Detector efficiency:**

The efficiency of a detector is a measure of how many pulses occur for a given number of gamma rays.

- a. Absolute Efficiency: The ratio of the number of counts produced by the detector to the number of gamma rays emitted by the source (in all directions).
- b. Intrinsic Efficiency: The ratio of the number of pulses produced by the detector to the number of gamma rays striking the detector.
- c. Relative Efficiency: Efficiency of one detector relative to another;
- d. Full-Energy Peak (or Photopeak) Efficiency: The efficiency for producing full-energy peak pulses only, rather than a pulse of any size for the gamma ray.

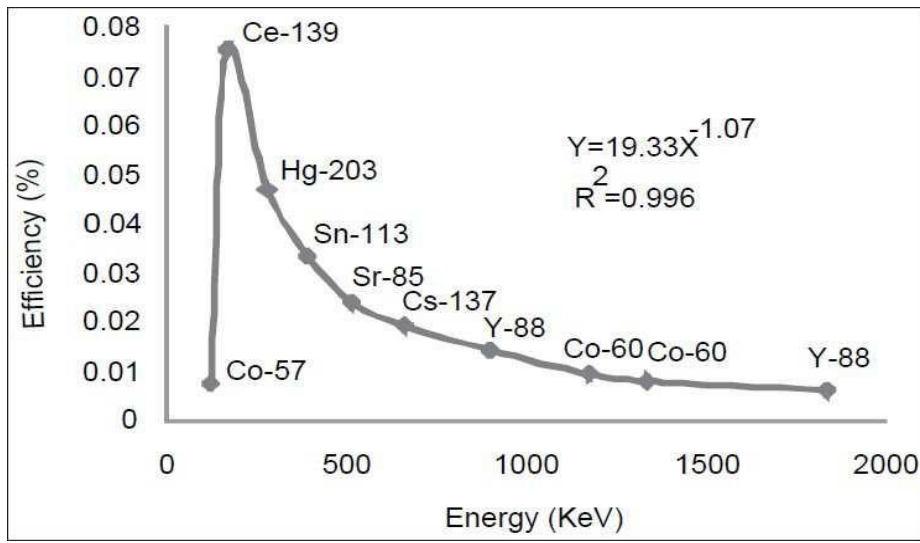

**Detector Resolution:**

It is a measure of the width (full width half max) of a single energy peak at a specific energy. Better (lower FWHM value) resolution enables the system to more clearly separate the peaks within a spectrum. Figure shows two spectra collected from the same source, one using a (NaI(Tl)) and one using (HPGe). The peaks presented by the (NaI) are overlapping to some degree, while those from the HPGe are clearly separated.

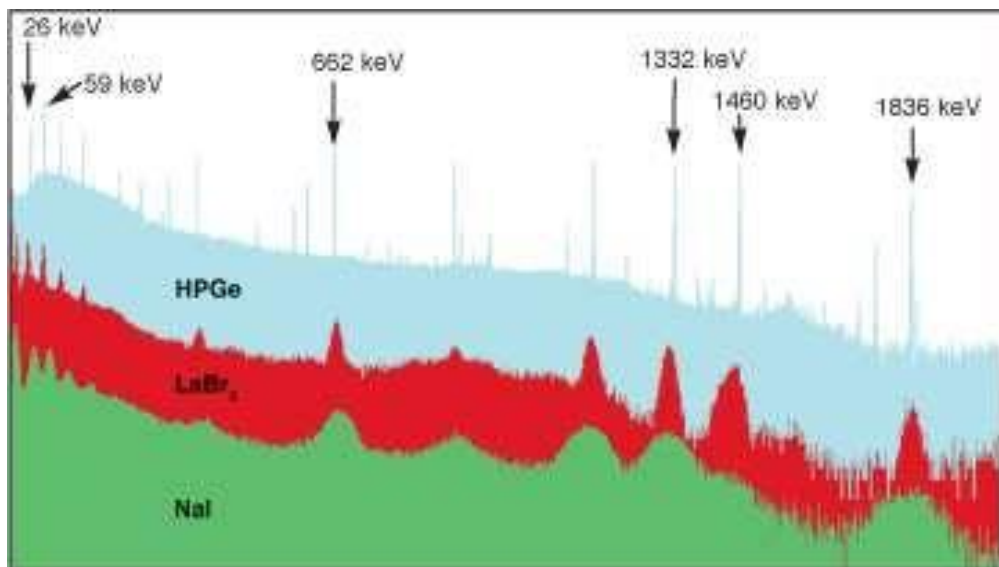

**Typical gamma spectrum**

In addition to the sharp peaks (photopeak), there are lower energies, result from scattering of electrons in the crystal by the incident gamma rays.

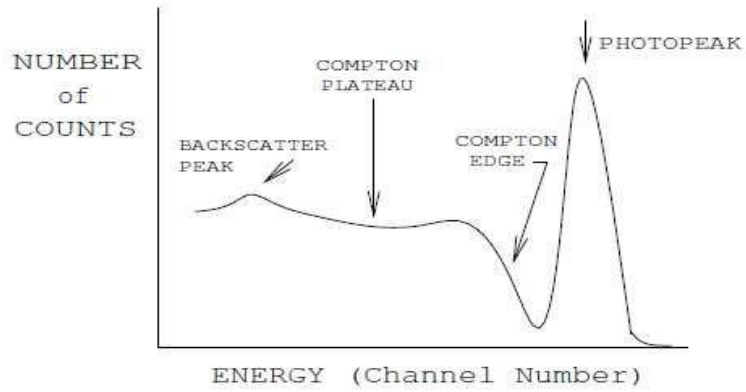

## **Solid State Nuclear Track Detectors (SSNTDs)**

SSNTDs are different from ionization chambers, proportional counters, and Geiger counters. They are used in the investigation of uranium exploration and in the detection of radon gas environmentally. They are sensitive to alpha and insensitive to beta and gamma. Because beta and gamma do not produce etch able individual tracks.

### **Advantages:**

1. Simplicity of its methodology.
2. Low cost.
3. Great versatility of its possible applications.
4. Small geometry of the detectors.
5. Ability to preserve their track record for infinite time.
6. Do not require energy source to be operated.
7. Unaffected by humidity, low temperatures, heating and light.

### **Types:**

They classify into organic and inorganic detectors, as well as into naturally occurring (feldspar, mica, quartz, etc.) And man-made detectors (CR-39, CN-85, LR-115, etc.).

#### **A) Inorganic Detectors**

They are the detectors that don't contain hydrogen in their composition, and their molecules are linked by ionic bonds.

**B) Organic Detectors**

They are containing hydrogen in their composition, and their molecules are linked by covalent bonds.

These types differ in their sensitivity which increasing with increasing the atomic number of the incident particle.

**Organic Solid State Nuclear Track Detector**

Detector material	Etching condition	Lightest detectable particle
Polycarbonate plastics (Lexan, Makrafol, milar)	6N, NaOH, 60°C, 60min	He(0.3MeV)
Allyldiglycol Polycarbonate (CR-39)	6N, NaOH, 70°C, 1-4hrs	H(1.0MeV)

**Inorganic Solid State Nuclear Track Detector**

Detector material	Etching condition	Lightest detectable particle
<b>Crystals</b>		
Olivine	KOH Solu, 160°C, 6 min	Fe
Zircon	85% H <sub>3</sub> PO <sub>4</sub> 500°C / 1min	Ca
Quartz	KOH Solu / 210°C / 10min	Ar (100Mev)
Mica	48% HF/23°C/ 3Sec-40 min	Ne (20Mev)
<b>Glasses</b>		
Sodalime glass	48 % HF / 23°C 3Sec	Ne (20MeV)
Phosphate glass	48% HF /23°C 3Sec	F (20Mev)

**Formation of a latent track:**

When a charged particle passes through an insulating solid it leaves a narrow path of damage along the incident particle's passage. In plastic, the radiation damage consists of broken polymer chains which are chemically reactive. Certain chemical reagents attack the damaged regions of the plastic and

produce cone-shaped etch pits with the damaged path as an axis, so that the damage track may be revealed by chemical etching and made visible by optical microscope. The path of radiation damage depends on the ionization produced by the incident charged particle and is different for different incident particles and different media.

The track formation only occurs when the ionization in the vicinity exceeds a certain threshold value - the registration threshold of the detector. If the ionization by the particle is below the registration threshold of the detector, then no etchable track is formed. All particles with ionization values above the threshold value will be recorded.

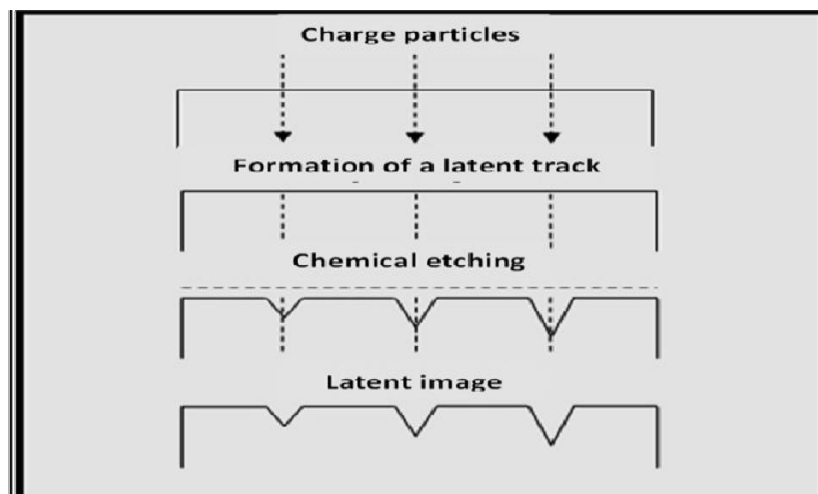
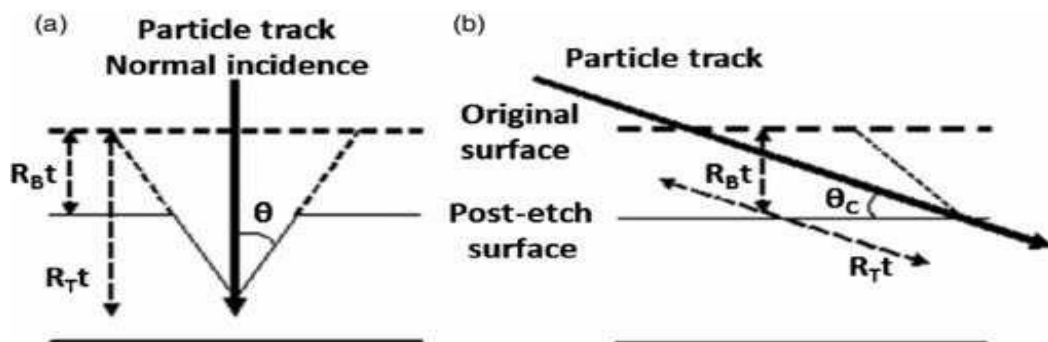

**Characteristics of nuclear latent track :**

1. The track consists of the damaged region along the path of the projectile .
2. The particle track is reactive centers towards chemical reagents due to presence of unstable centers along the trajectory.
3. The particle tracks are stable and can be viewed when required.
4. The track region has atomically continued along the path with a diameter of less than 10 nm.
5. The length of the damaged trail is equal to the range of the particle in the material.

**Detection thresholds of track detectors:**

The detection thresholds of different solid state nuclear track detectors vary considerably and depend upon the atomic number (Z) and energy (E), as well as the velocity (v) of the charged particle. The parameter  $Z/\beta$  (where  $\beta = v/c$ ) is normally used to characterize the minimum detection limit of a detector.

Some nuclear track detectors and their specifications.

Type	Atomic composition	Z threshold	Maximum detectable energy of alpha at the detector (MeV)
CR-39	$C_{12}H_{18}O_7$	1	20
LR-115, CN-85 (cellulose nitrate)	$C_6H_8O_9N_2$ $C_6H_8O_8N_2$	2	4-4.5
DNC			3.5-4
Lexan,	$C_{16}H_{14}O_3$	$\geq 6$	2-3

**Etching techniques :****1. Chemical etching (CE)**

Chemical etching is processes of path formation, during which a suitable etching attacks the detector at a sufficient speed and the damaged regions along the ion trails (latent track) are preferentially dissolved, removed and get transformed into a hollow channel.

The radiation damage trails are more vulnerable to chemical reactions as compared to other bulk material because of the large free energy associated with the disordered structure. When these channels reach a width comparable to the wavelength of visible light, they act as strong scattering centers appearing black in the normal bright illuminated field and can be seen under optical microscope.

Each SSNTDs has its own etch parameters. The choice of etching solution, the temperature of the etching and the time of etching are the critical parameters which must be taken into consideration during the etching process.

The most common etching for plastics is aqueous solutions of NaOH or KOH with concentrations ranging from 1-12 N and temperatures in the range between 40-90 C°. The etched tracks depend on the following conditions as in table below:

- Types of track detectors.
- The charge, mass and velocity of the incoming particle.
- The environmental conditions of exposed detectors.
- Type, concentration the chemical solution, temperature of etching.



Some etching conditions for organic and inorganic nuclear track detectors.

Detector material	Etching conditions (Etchant, molarity, temperature and time)
(LR-115, CN-85, DNC)	NaOH, 1-12M, 40-70°C, 2-4 h
(Lexan, Makrofol)	NaOH, 1-12 M, 40-70°C, 20 min
(CR-39)	NaOH (KOH), 6M, 60°C, 12 h

### Parameters track etching :

#### 1. Bulk etch rate ( $V_B$ ):

The bulk etch rate of the unaffected surface of the detector and is given by:

$$V_B = \frac{D}{2t}$$

Where the diameter of the track  $D$  is computed by taking the average radius of several tracks viewed by camera, and  $t$  is the etching time.

#### 2. Track etch rate ( $V_T$ ) :

The rate of etching along the latent track is given by:

$$V_T = V_B \frac{1 + \left(\frac{V_D}{V_B}\right)^2}{1 - \left(\frac{V_D}{V_B}\right)^2}$$

Where  $V_D$  is the average diameter of the tracks registered in the detector; it is computed from the slope of the track diameter ( $V_D = \Delta D / \Delta t$ ).

#### 3. Etching rate ratio ( $V$ ):

The ratio of the speed of etching the track ( $V_T$ ) to the speed of etching the surface ( $V_B$ ), and is given by:

$$V = \frac{V_T}{V_B}$$

#### 4. Critical angle of etching ( $\theta_c$ )

There are three probabilities of the angle that the particle incident on the detector relative to the critical angle.

- Particle incident at an angle larger than the critical angle ( $\theta > \theta_c$ ), in this case the latent track is never developed by etching the detector.
- Particle incident at an angle equal to the critical angle ( $\theta = \theta_c$ ), in this case the latent track is failed to developed inspite of being formed.
- Particle incident at an angle smaller than the critical angle ( $\theta < \theta_c$ ). In this case no track is observed because the surface is removed. The critical angle is calculated from the following equation.

$$\theta_c = \sin^{-1}\left(\frac{V_B}{V_T}\right)$$

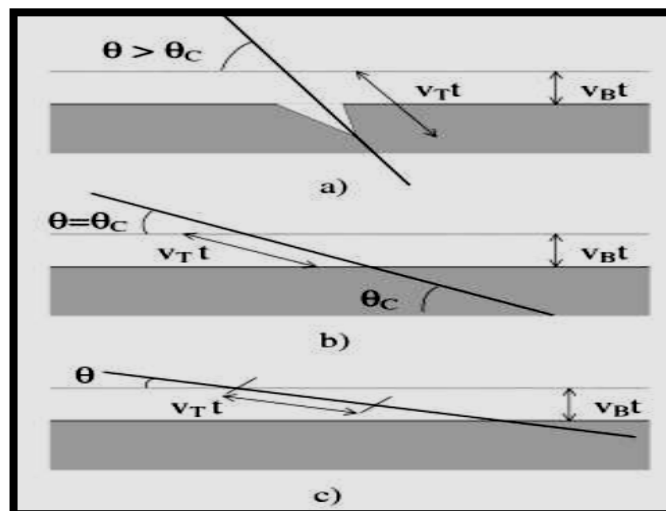

#### 5. Etching efficiency ( $\eta$ )

Etching efficiency depends on the track etched rate, velocity  $V_T$  and the bulk etched rate velocity  $V_B$ :

$$\eta = 1 - \left(\frac{V_B}{V_T}\right)$$

## Experimental Error and Data Analysis

In the measurement of any quantity, an error or a deviation from the true value of the quantity is likely to occur. Radioactive atoms decay at random, independently from each other. For that reason; all measurements of radioactivity have an inherent, uncontrollable random error.

### Types of errors:

#### 1. Systematic Errors:

Systematic errors arise from malfunctioning devices and inappropriate experimental conditions and can be corrected by rectifying the situation by:

1. Calibrate the device: by finding zero error of the device.
2. Find the error produced by the measuring instrument.

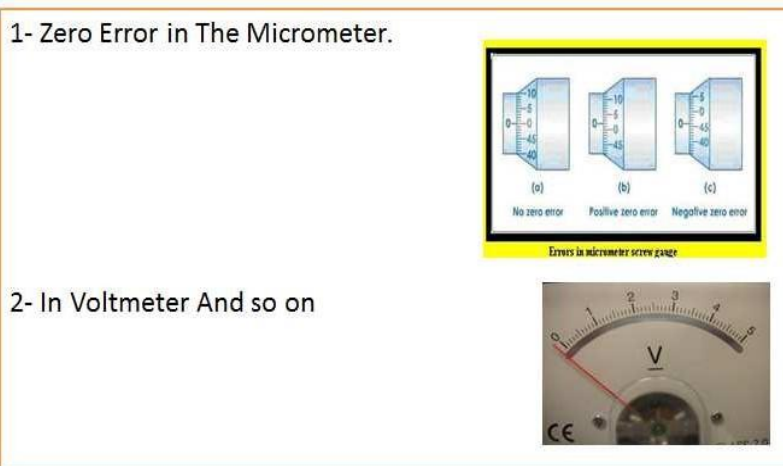

#### 2. Random Errors:

Random errors arise from random fluctuations in the experimental conditions, for example, high-voltage fluctuations. Radioactive decay is an example of this error. They are uncontrollable, and appear in most experiments from unknown reasons to the student such as:

1. Bad use of the device or extend device life.
2. Change in the circumstances surrounding the experiment: vibration, temperature, humidity, and pressure.

**3. Personal Errors "Blunders":**

It's due to carelessness, negligence, or ignorance, and are controllable.

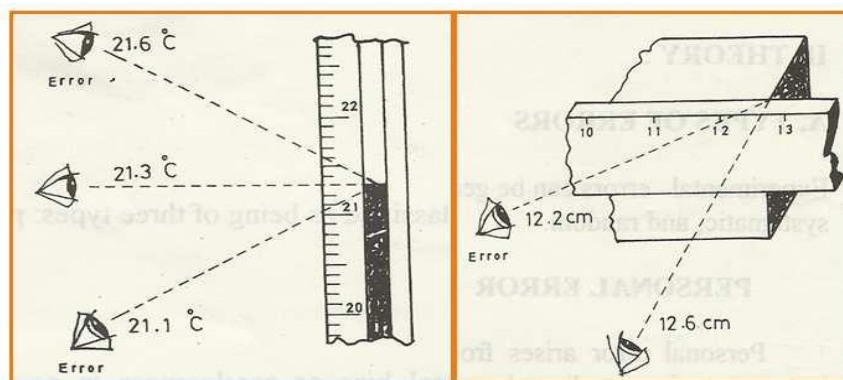

Different angle of view

**Accuracy:** الدقة

The accuracy of a measurement indicates how close the measured value to its real value.

دقیق بودن اندازه گیری را دقت می گویند. دقت به آن اشاره دارد که اندازه گیری چقدر به مقدار واقعی نزدیک است.

**Precision:** دقت

The precision of a series of measurements describes the reproducibility of the measurement and indicates the deviation from the "average" value.

دقت به آن اشاره دارد که اندازه گیری چقدر به هم نزدیک است. دقت به آن اشاره دارد که اندازه گیری چقدر به هم نزدیک است.

دقت بودن اندازه گیری را دقت می گویند. دقت به آن اشاره دارد که اندازه گیری چقدر به هم نزدیک است.

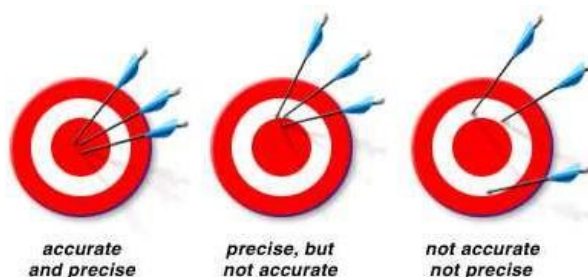

Example:

Mention the accuracy and the precision of three student's measures, for three times measures of lead density if you know that the lead density is (11.34 gm/cm<sup>3</sup>).

student	measures ( lead density gm/cm <sup>3</sup> )			Accuracy	Precision
1	11.32	11.35	11.32	accurate	Precise
2	11.42	11.44	11.42	not accurate	Precise
3	11.04	11.34	11.04	not accurate	not Precise

### Measures of Central Tendency

قياسات الميل المركزي

Measures of central tendency are a value that represents a typical, or central, entry of a data set. The most common measures of central tendency are:

#### 1. Mean or Average (x):

The sum of all the data entries divided by the number of entries.

$$\bar{x} = \frac{\sum x_i}{n}$$

**Example:**

Data Set = 2, 5, 9, 3, 5, 4, 7

Number of Elements in Data Set = 7

Mean = (2 + 5 + 9 + 7 + 5 + 4 + 3) / 7 = 5

#### 2. Median (M):

It is the value that lies in the middle of the data when the data set is ordered.

**Example:** Odd Number of Elements

Data Set = 2, 5, 9, 3, 5, 4, 7

Reordered = 2, 3, 4, 5, 5, 7, 9

Median = 5

**Example:** Even Number of Elements

Data Set = 2, 5, 9, 3, 5, 4

Reordered = 2, 3, 4, 5, 5, 9Median =  $(4 + 5) / 2 = 4.5$ **3. Mode:**

It is the data entry that occurs with the greatest frequency or repeat.

**Example (1):** find the number of mode of: 3, 6, 4, 3, 2, 4, 7, 8, 6, 3, 9

Ascending order: 2, 3, 3, 3, 4, 4, 6, 6, 7, 8, 9. The mode is = (3).

**Example (2):** find the mode of the students out of 50 in class which given below in the table:

marks	42	36	30	45	50
number of students	7	10	13	8	2

The mode is =30

**Measures of Variation:****1. Range:**

It is the difference between the maximum and minimum data entries in the set.

Range = (Max. data entry) - (Min. data entry).

**Examples:** Data Set = 2, 5, 9, 3, 5, 4, 7

Reordered = 2, 3, 4, 5, 5, 7, 9

Range =  $(9 - 2) = 7$ **2. Variance ( $\sigma^2$ ):**  $\sigma^2 = \frac{\sum (x_i - \bar{x})^2}{n}$  هو a و ط ar! ات: راف a م > ن و ط a! 1

It's the average squared deviation of values from mean. Expressed by:

$$s^2 = \frac{\sum (x - \bar{x})^2}{n} \quad \text{or} \quad \text{VAR} = \frac{\sum (x_i - \bar{x})^2}{n - 1}$$

هو N91 ذر ال91 رD^O ا; وNب 1DLH9 ان

3. **Standard deviation ( $\sigma$ )** : ا8:راف ال; 1i0 ري:

It's the square root of variance; and Expressed by:

Standard Deviation for Population 
$$\sigma = \sqrt{\frac{\sum(x_i - m)^2}{n}}$$

Standard Deviation for Sample 
$$s_x = \sqrt{\frac{\sum(x_i - \bar{x})^2}{n - 1}}$$

Where:

$m$  = mean value,

$x_i$  = value of the  $i^{\text{th}}$  measurement,

$n$  = total number of observations.

$\bar{x}$  = sample mean

4. **The standard error of the mean ( $\sigma_x$ ) :**

The standard error of the mean is given by:

$$\sigma_{\bar{x}} = \frac{\sigma}{\sqrt{n}}$$

Where  $\sigma$  is the standard deviation of the population and  $n$  is the sample size.

**Example:** find the sample variance, sample standard deviation, and mean.

No.	observation( x)	mean (x)	(xi- x)	(xi- x) <sup>2</sup>
1	17	14	17-14=3	9
2	15	14	15-14=1	1
3	23	14	9	81
4	7	14	-7	49
5	9	14	-5	25
6	13	14	-1	1
	84	14	0	166

**1. For Sample:**

$$\text{Variance} = \sigma^2 = \frac{(x_i - \bar{x})^2}{n-1} = \frac{166}{5} = 33.2$$

$$\text{Standard deviation} = \sigma = 5.76.$$

$$\text{Standard error} = \frac{\sigma}{\sqrt{n}} = \frac{5.76}{2.23} = 2.58$$

**2. For Population**

$$\text{Variance} = \sigma^2 = \frac{(x_i - \mu)^2}{n} = \frac{166}{6} = 27.66$$

$$\text{Standard deviation} = \sigma = 5.25.$$

**Example:** Find Population Mean and Sample Standard Deviation for the following data set: 5, 10, 15, 20.

*Sample statistics are estimates of population parameters:*

	symbol used for the population <i>parameter</i>	symbol used for the sample <i>statistic</i>
mean	$\mu$	$\bar{x}$
standard deviation	$\sigma$	$s$
variance	$\sigma^2$	$s^2$
standard error	$\frac{\sigma}{\sqrt{n}}$	$\frac{s}{\sqrt{n}}$

**5. Coefficient of variation (CV):**

Its expresses the S.D. as a percentage of the sample mean. Very often in dealing with biologic data we find that the s.d. is large for samples with a large  $\bar{x}$  and vice versa. To cope with this type of problem, a quantity called either the "coefficient of variation" (CV), or the "relative s.d.," or the "percent s.d." is calculated as:



$$CV = \frac{s}{\bar{x}} \times 100\%$$

This is a unit less measure; e.g., in the previous example we calculate:

$$CV = \frac{\text{s.d.}}{\bar{x}} = \frac{53.24 \text{ cpm/mg}}{47.18 \text{ cpm/mg}} = 1.13 \text{ or } 113\% \text{ s.d.,}$$

### Example:

Calculate mean, sample standard deviation, and sample variance for nine measurements, if the time of each measure is two minutes using a specific radiation detector.

no.	count result (2m)	mean count (c/m)	$X_i - \bar{X}$	$(X_i - \bar{X})^2$
1	4496	2248	2248 - 2234 = +14	196
2	4459	2230	2230 - 2234 = -4	16
3	4505	2252	2252 - 2234 = +18	324
4	4468	2234	2234 - 2234 = 0	0
5	4464	2232	2232 - 2234 = -2	4
6	4444	2222	2222 - 2234 = -12	144
7	4526	2263	2263 - 2234 = +29	841
8	4491	2246	2246 - 2234 = +12	144
9	4353	2176	2176 - 2234 = -58	3364
N = 9		$\bar{X} = 20103/9 = 2234$		4943

a. Mean ( $\bar{X}$ ) =  $\frac{\sum X_i}{N} = \frac{20103}{9} = 2233.6 \text{ c/m}$

b. Sample Variance ( $\sigma_x^2$ ) =  $\frac{\sum (X_i - \bar{X})^2}{(N-1)} = \frac{4943}{8} = 617.875$

c. Sample Standard Deviation ( $\sigma_x$ ) =  $\sqrt{617.875} = 24.857$

d. Standard error  $\sigma_x = \frac{\sigma_x}{\sqrt{n}} = \frac{24.857}{\sqrt{9}} = \frac{24.857}{3} = 8.286$

$$e. \text{ Coefficient of variation (CV)} = \frac{\sigma_x}{\sqrt{X}} = \frac{25}{2234} \times 100\% = 1.1\% \text{ for population.}$$

If we need to calculate (CV) for the 4th read accumulated at (2m) which = 4468:

$$CV = \frac{\sqrt{4468}}{4468} \times 100\% = \frac{67}{4468} \times 100\% = \pm 1.5\% .$$

## Statistical distributions

### 1. Poisson Distribution

The Poisson distribution is a discrete probability distribution for the counts of events that occur randomly in a given interval of time (or space).

If:  $X$  = the number of events in a given interval,

$\lambda$  = the mean number of events per interval,

$x$  = events in a given interval

Then, the probability of observing ( $x$ ) events in a given interval are given by:

$$P(X=x) = e^{-\lambda} \frac{\lambda^x}{x!} \quad x = 0, 1, 2, 3, 4, \dots$$

#### **Example:**

The average number of accidents at a level-crossing every year is 5. Calculate the probability that there are exactly 3 accidents there this year.

**Solution:** Here,  $\lambda = 5$ , and  $x = 3$ .

$$P(X=3) = \frac{e^{-\lambda} \lambda^x}{x!} = \frac{e^{-5} \times 5^3}{3!} = 0.1404 .$$

there is a 14% chance that there will be exactly 3 accidents there this year.

Poisson distribution is a bell-shaped curve that best describes the frequencies of radioactivity measurements around the mean value. The curve is slightly asymmetric and skewed toward the high values.

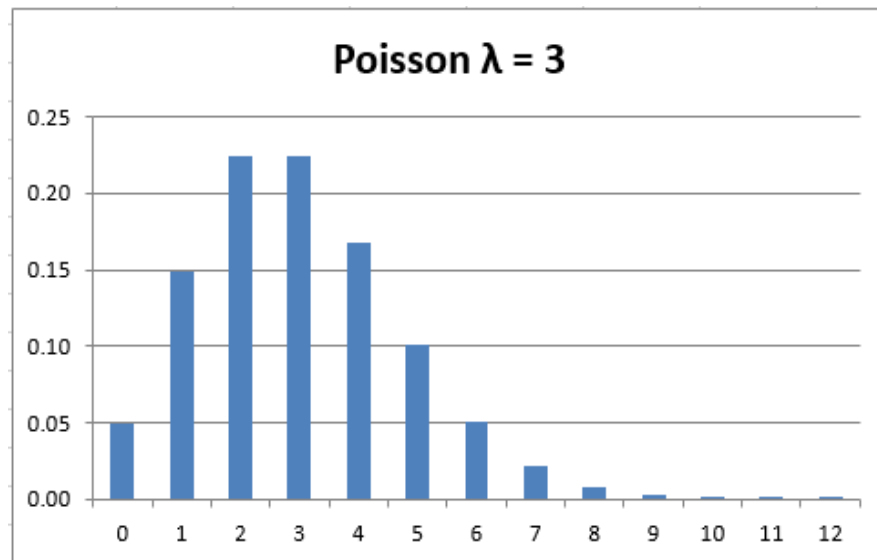

## 2. Gaussian Distribution:

Also known as "**normal distribution**", it is close to Poisson distribution. The curve is symmetrical and, for that reason, easier to use. Its parameters are  $m$ , the true mean, and  $s$ , the standard deviation.

