

Basics of Electricity

Dr Abouelwafa Salem

2022-2023

Table of Contents

Introduction.....	2
Electron Theory.....	4
Conductors, Insulators and Semiconductors.....	5
Electric Charges.....	7
Current.....	9
Voltage.....	11
Resistance.....	13
Simple Electric Circuit.....	15
Ohm's Law.....	16
DC Series Circuit.....	18
DC Parallel Circuit.....	23
Series-Parallel Circuits.....	30
Power.....	34
Magnetism.....	37
Electromagnetism.....	39
Introduction to AC.....	42
AC Generators.....	44
Frequency.....	47
Voltage and Current.....	48
Inductance.....	51
Capacitance.....	56
Inductive and Capacitive Reactance.....	61
Series R-L-C Circuit.....	67
Parallel R-L-C Circuit.....	69
Power and Power Factor in an AC Circuit.....	71
Transformers.....	75
Three-Phase Transformers.....	80
Review Answers.....	83
Final Exam.....	84

Introduction

Welcome to the first course in the STEP series, Siemens Technical Education Program designed to prepare our distributors to sell Siemens Energy & Automation products more effectively. This course covers Basics of Electricity and is designed to prepare you for subsequent courses on Siemens Energy & Automation products.

Upon completion of Basics of Electricity you will be able to:

- Explain the difference between conductors and insulators
- Use Ohm's Law to calculate current, voltage, and resistance
- Calculate equivalent resistance for series, parallel, or series-parallel circuits
- Calculate voltage drop across a resistor
- Calculate power given other basic values
- Identify factors that determine the strength and polarity of a current-carrying coil's magnetic field
- Determine peak, instantaneous, and effective values of an AC sine wave
- Identify factors that effect inductive reactance and capacitive reactance in an AC circuit
- Calculate total impedance of an AC circuit
- Explain the difference between real power and apparent power in an AC circuit
- Calculate primary and secondary voltages of single-phase and three-phase transformers
- Calculate kVA of a transformer

The objectives listed above may sound strange to you. You may also wonder why you would need to know these things to sell Siemens Energy & Automation products. Developing a basic knowledge of electrical concepts, however, will help you to better understand customer applications. In addition, you will be better able to describe products to customers and determine important differences between products.

If you are an employee of a Siemens Energy & Automation authorized distributor, fill out the final exam tear-out card and mail in the card. We will mail you a certificate of completion if you score a passing grade. Good luck with your efforts.

Electron Theory

Elements of an Atom

All matter is composed of molecules which are made up of a combination of atoms. Atoms have a nucleus with electrons orbiting around it. The nucleus is composed of protons and neutrons (not shown). Most atoms have an equal number of electrons and protons. Electrons have a negative charge (-). Protons have a positive charge (+). Neutrons are neutral. The negative charge of the electrons is balanced by the positive charge of the protons. Electrons are bound in their orbit by the attraction of the protons. These are referred to as bound electrons.

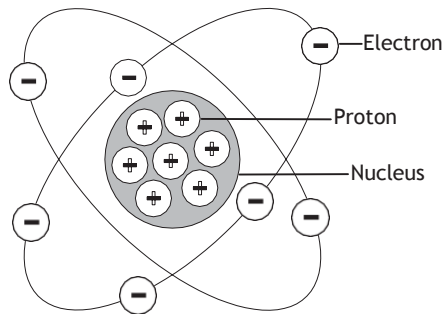

Free Electrons

Electrons in the outer band can become free of their orbit by the application of some external force such as movement through a magnetic field, friction, or chemical action. These are referred to as free electrons. A free electron leaves a void which can be filled by an electron forced out of orbit from another atom. As free electrons move from one atom to the next an electron flow is produced. This is the basis of electricity.

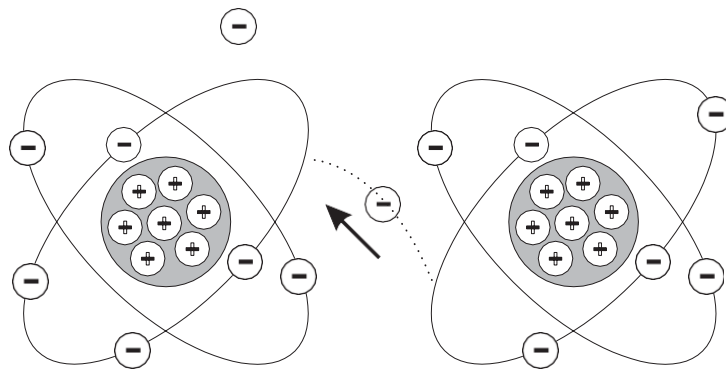

Conductors, Insulators and Semiconductors

Conductors

An electric current is produced when free electrons move from one atom to the next. Materials that permit many electrons to move freely are called conductors. Copper, silver, aluminum, zinc, brass, and iron are considered good conductors. Copper is the most common material used for conductors and is relatively inexpensive.

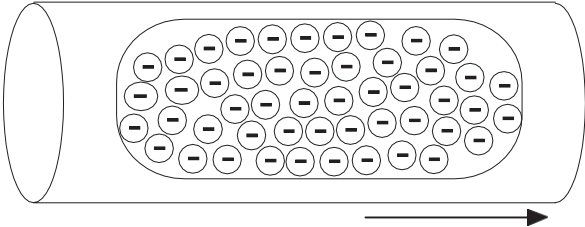

Insulators

Materials that allow few free electrons are called insulators. Materials such as plastic, rubber, glass, mica, and ceramic are good insulators.

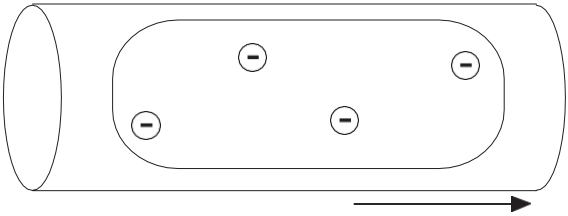

An electric cable is one example of how conductors and insulators are used. Electrons flow along a copper conductor to provide energy to an electric device such as a radio, lamp, or a motor. An insulator around the outside of the copper conductor is provided to keep electrons in the conductor.



Semiconductors

Semiconductor materials, such as silicon, can be used to manufacture devices that have characteristics of both conductors and insulators. Many semiconductor devices will act like a conductor when an external force is applied in one direction. When the external force is applied in the opposite direction, the semiconductor device will act like an insulator. This principle is the basis for transistors, diodes, and other solid-state electronic devices.

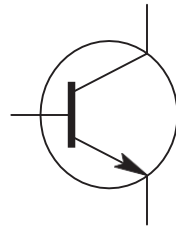

Transistor



Diode

Review 1

1. List the three basic elements of an atom and state the charge of each (positive, negative, or neutral).

Element	Charge
_____	_____
_____	_____
_____	_____

2. An electron forced out of orbit by an external force is called a _____ .
3. Conductors allow _____ free electrons to flow when an external electric force is applied.
4. Which of the following materials are good conductors?
 - a. copper
 - b. plastic
 - c. silver
 - d. rubber
 - e. aluminum
 - f. glass
 - g. iron
 - h. mica
5. Semiconductor devices can be manufactured to allow _____ electrons to flow in one direction and _____ electrons to flow in the opposite direction.

Electric Charges

Neutral State of an Atom

Elements are often identified by the number of electrons in orbit around the nucleus of the atoms making up the element and by the number of protons in the nucleus. A hydrogen atom, for example, has only one electron and one proton. An aluminum atom (illustrated) has 13 electrons and 13 protons. An atom with an equal number of electrons and protons is said to be electrically neutral.

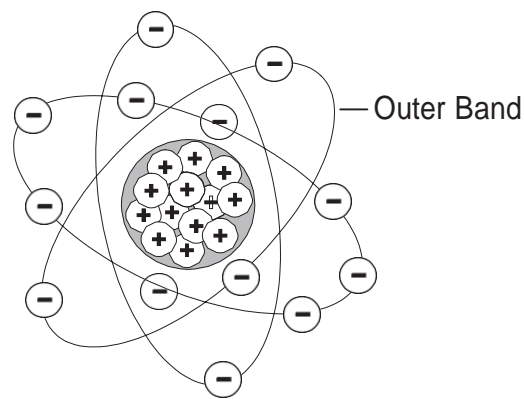

Positive and Negative Charges

Electrons in the outer band of an atom are easily displaced by the application of some external force. Electrons which are forced out of their orbits can result in a lack of electrons where they leave and an excess of electrons where they come to rest. The lack of electrons is called a positive charge because there are more protons than electrons. The excess of electrons has a negative charge. A positive or negative charge is caused by an absence or excess of electrons. The number of protons remains constant.

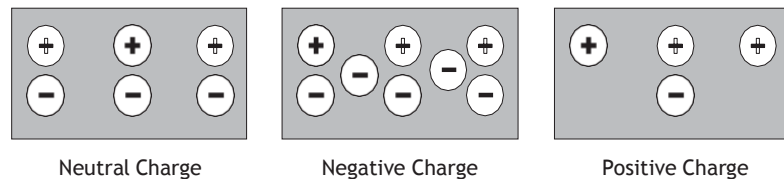

Attraction and Repulsion of Electric Charges

The old saying, “opposites attract,” is true when dealing with electric charges. Charged bodies have an invisible electric field around them. When two like-charged bodies are brought together, their electric field will work to repel them. When two unlike-charged bodies are brought together, their electric field will work to attract them. The electric field around a charged body is represented by invisible lines of force. The invisible lines of force represent an invisible electrical field that causes the attraction and repulsion. Lines of force are shown leaving a body with a positive charge and entering a body with a negative charge.

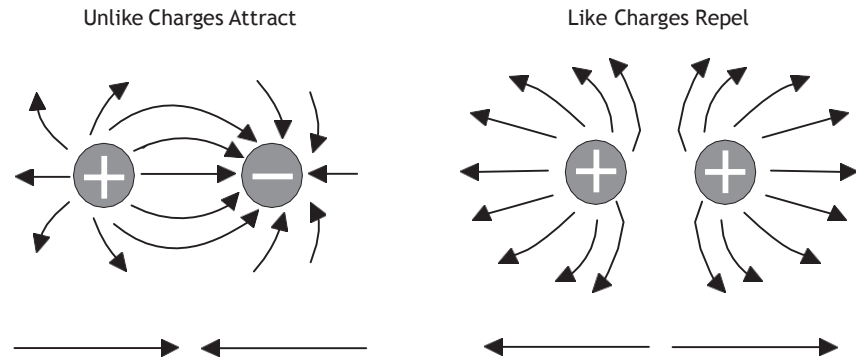

Coulomb's Law

During the 18th century a French scientist, Charles A. Coulomb, studied fields of force that surround charged bodies. Coulomb discovered that charged bodies attract or repel each other with a force that is directly proportional to the product of the charges, and inversely proportional to the square of the distance between them. Today we call this Coulomb's Law of Charges. Simply put, the force of attraction or repulsion depends on the strength of the charged bodies, and the distance between them.

Current

Electricity is the flow of free electrons in a conductor from one atom to the next atom in the same general direction. This flow of electrons is referred to as current and is designated by the symbol “I.” Electrons move through a conductor at different rates and electric current has different values. Current is determined by the number of electrons that pass through a cross-section of a conductor in one second. We must remember that atoms are very small. It takes about 1,000,000,000,000,000,000,000,000 atoms to fill one cubic centimeter of a copper conductor. This number can be simplified using mathematical exponents. Instead of writing 24 zeros after the number 1, write 10^{24} . Trying to measure even small values of current would result in unimaginably large numbers. For this reason current is measured in amperes which is abbreviated “amps.” The letter “A” is the symbol for amps. A current of one amp means that in one second about 6.24×10^{18} electrons move through a cross-section of conductor. These numbers are given for information only and you do not need to be concerned with them. It is important, however, that the concept of current flow be understood.

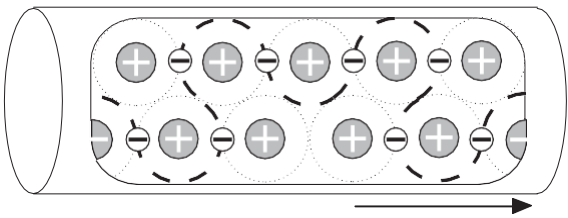

Units of Measurement

The following chart reflects special prefixes that are used when dealing with very small or large values of current:

Prefix	Symbol	Decimal
1 kiloampere	1 kA	1000 A
1 milliampere	1 mA	1/1000 A
1 microampere	1 μ A	1/1,000,000 A

Direction of Current Flow

Some authorities distinguish between electron flow and current flow. Conventional current flow theory ignores the flow of electrons and states that current flows from positive to negative. To avoid confusion, this book will use the electron flow concept which states that electrons flow from negative to positive.

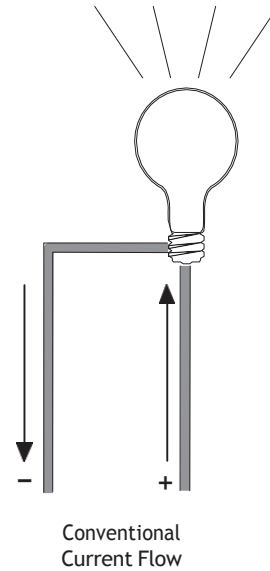
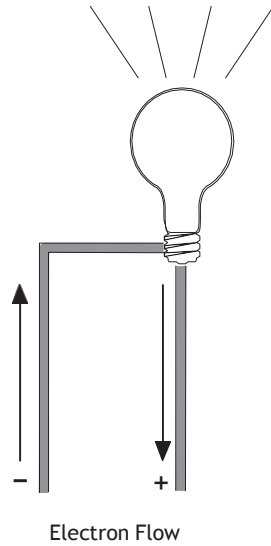

Voltage

Electricity can be compared with water flowing through a pipe. A force is required to get water to flow through a pipe. This force comes from either a water pump or gravity. Voltage is the force that is applied to a conductor that causes electric current to flow.

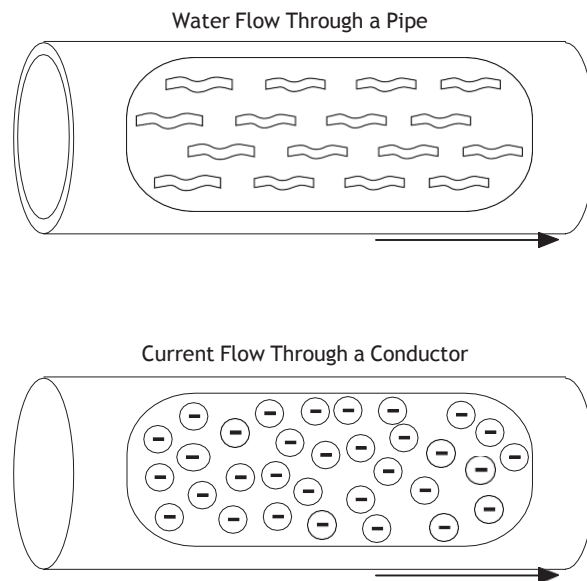

Electrons are negative and are attracted by positive charges. They will always be attracted from a source having an excess of electrons, thus having a negative charge, to a source having a deficiency of electrons which has a positive charge. The force required to make electricity flow through a conductor is called a difference in potential, electromotive force (emf), or more simply referred to as voltage. Voltage is designated by the letter "E," or the letter "V." The unit of measurement for voltage is volts which is also designated by the letter "V."

Voltage Sources

An electrical voltage can be generated in various ways. A battery uses an electrochemical process. A car's alternator and a power plant generator utilizes a magnetic induction process. All voltage sources share the characteristic of an excess of electrons at one terminal and a shortage at the other terminal. This results in a difference of potential between the two terminals.

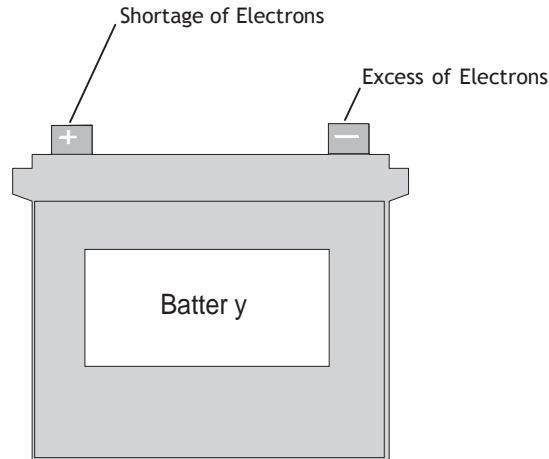

Voltage Circuit Symbol

The terminals of a battery are indicated symbolically on an electrical drawing by two lines. The longer line indicates the positive terminal. The shorter line indicates the negative terminal.

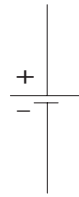

Units of Measurement

The following chart reflects special prefixes that are used when dealing with very small or large values of voltage:

Prefix	Symbol	Decimal
1 kilovolt	1 kV	1000 V
1 millivolt	1 mV	1/1000 V
1 microvolt	1 μ V	1/1,000,000 V

Resistance

A third factor that plays a role in an electrical circuit is resistance. All material impedes the flow of electrical current to some extent. The amount of resistance depends upon composition, length, cross-section and temperature of the resistive material. As a rule of thumb, resistance of a conductor increases with an increase of length or a decrease of cross-section. Resistance is designated by the symbol "R." The unit of measurement for resistance is ohms (Λ).

Resistance Circuit Symbols

Resistance is usually indicated symbolically on an electrical drawing by one of two ways. An unfilled rectangle is commonly used. A zigzag line may also be used.

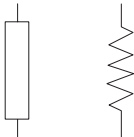

Resistance can be in the form of various components. A resistor may be placed in the circuit, or the circuit might contain other devices that have resistance.

Units of Measurement

The following chart reflects special prefixes that are commonly used when dealing with values of resistance:

Prefix	Symbol	Decimal
1 kilohm	1 k Λ	1000 Λ
1 megohm	1 M Λ	1,000,000 Λ

Review 2

1. Elements are identified by the number of _____ in orbit around the nucleus.
2. A material that has an excess of electrons is said to have a _____ charge.
3. A material that has a deficiency of electrons is said to have a _____ charge.
4. Like charges _____ and unlike charges _____ .
5. The force that is applied to a conductor to cause current flow is _____ .
6. Electrons move from _____ .
 - a. positive to negative
 - b. negative to positive
7. With an increase of length or a decrease of cross-section of a conductor, resistance will _____ .
 - a. increase
 - b. decrease

Simple Electric Circuit

An Electric Circuit

A fundamental relationship exists between current, voltage, and resistance. A simple electric circuit consists of a voltage source, some type of load, and a conductor to allow electrons to flow between the voltage source and the load. In the following circuit a battery provides the voltage source, electrical wire is used for the conductor, and a light provides the resistance. An additional component has been added to this circuit, a switch. There must be a complete path for current to flow. If the switch is open, the path is incomplete and the light will not illuminate. Closing the switch completes the path, allowing electrons to leave the negative terminal and flow through the light to the positive terminal.

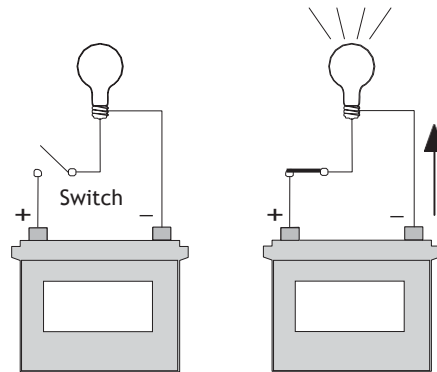

An Electrical Circuit Schematic

The following schematic is a representation of an electrical circuit, consisting of a battery, a resistor, a voltmeter and an ammeter. The ammeter, connected in series with the circuit, will show how much current flows in the circuit. The voltmeter, connected across the voltage source, will show the value of voltage supplied from the battery. Before an analysis can be made of a circuit, we need to understand Ohm's Law.

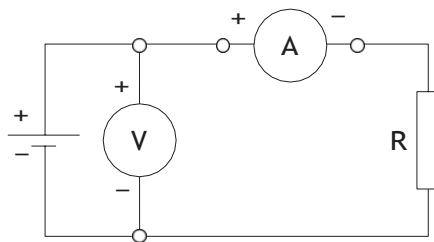

Ohm's Law

George Simon Ohm and Ohm's Law

The relationship between current, voltage and resistance was studied by the 19th century German mathematician, George Simon Ohm. Ohm formulated a law which states that current varies directly with voltage and inversely with resistance. From this law the following formula is derived:

$$I = \frac{E}{R} \quad \text{or} \quad \text{Current} = \frac{\text{Voltage}}{\text{Resistance}}$$

Ohm's Law is the basic formula used in all electrical circuits. Electrical designers must decide how much voltage is needed for a given load, such as computers, clocks, lamps and motors. Decisions must be made concerning the relationship of current, voltage and resistance. All electrical design and analysis begins with Ohm's Law. There are three mathematical ways to express Ohm's Law. Which of the formulas is used depends on what facts are known before starting and what facts need to be known.

$$I = \frac{E}{R} \quad E = I \times R \quad R = \frac{E}{I}$$

Ohm's Law Triangle

There is an easy way to remember which formula to use. By arranging current, voltage and resistance in a triangle, one can quickly determine the correct formula.

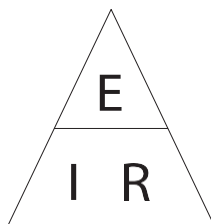

Using the Triangle

To use the triangle, cover the value you want to calculate. The remaining letters make up the formula.

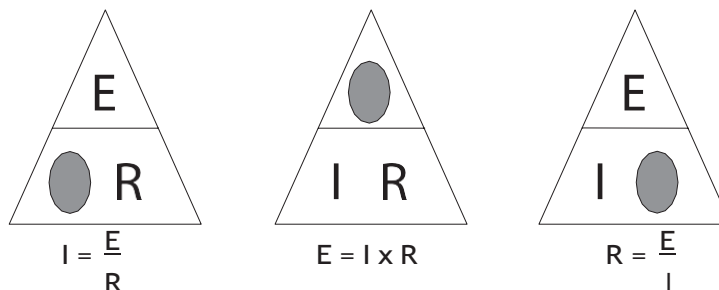

Ohm's Law can only give the correct answer when the correct values are used. Remember the following three rules:

- Current is always expressed in amperes or amps
- Voltage is always expressed in volts
- Resistance is always expressed in ohms

Examples of Solving Ohm's Law

Using the simple circuit below, assume that the voltage supplied by the battery is 10 volts, and the resistance is 5 Ω .

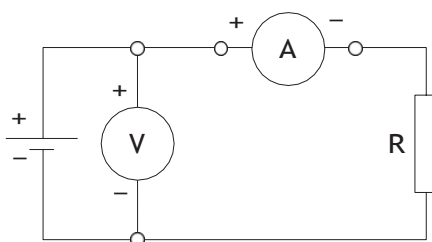

To find how much current is flowing through the circuit, cover the "I" in the triangle and use the resulting equation.

$$I = \frac{E}{R} \rightarrow I = \frac{10 \text{ Volts}}{5 \Omega} \rightarrow I = 2 \text{ Amps}$$

Using the same circuit, assume the ammeter reads 200 mA and the resistance is known to be 10 Ω . To solve for voltage, cover the "E" in the triangle and use the resulting equation.

$$E = I \times R \rightarrow E = 0.2 \times 10 \rightarrow E = 2 \text{ Volts}$$

Remember to use the correct decimal equivalent when dealing with numbers that are preceded with milli (m), micro (μ) or kilo (k). In this example had 200 been used instead of converting the value to 0.2, the wrong answer of 2000 volts would have been calculated.

DC Series Circuit

Resistance in a Series Circuit

A series circuit is formed when any number of resistors are connected end-to-end so that there is only one path for current to flow. The resistors can be actual resistors or other devices that have resistance. The following illustration shows four resistors connected end-to-end. There is one path of current flow from the negative terminal of the battery through R4, R3, R2, R1 returning to the positive terminal.

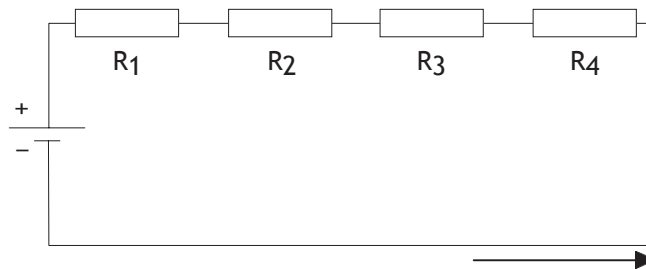

Formula for Series Resistance

The values of resistance add in a series circuit. If a 4 Ω resistor is placed in series with a 6 Ω resistor, the total value will be 10 Ω . This is true when other types of resistive devices are placed in series. The mathematical formula for resistance in series is:

$$R_t = R_1 + R_2 + R_3 + R_4 + R_5$$

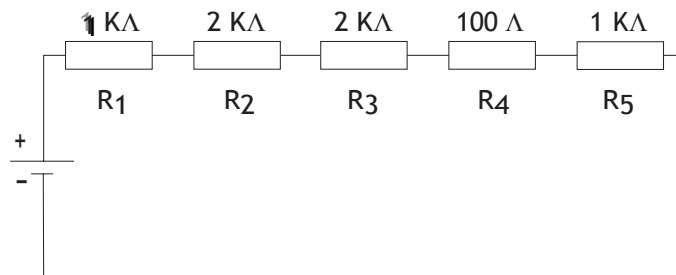

$$\begin{aligned} R_t &= R_1 + R_2 + R_3 + R_4 + R_5 \\ R_t &= 1,000 + 2,000 + 2,000 + 100 + 1,000 \\ R_t &= 16,100 \Omega \end{aligned}$$

Current in a Series Circuit

The equation for total resistance in a series circuit allows us to simplify a circuit. Using Ohm's Law, the value of current can be calculated. Current is the same anywhere it is measured in a series circuit.

$$I = \frac{E}{R}$$

$$I = \frac{12}{10}$$

$$I = 1.2 \text{ Amps}$$

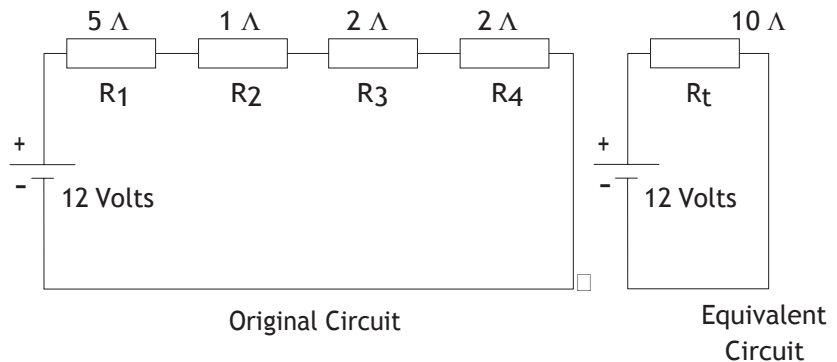

Voltage in a Series Circuit

Voltage can be measured across each of the resistors in a circuit. The voltage across a resistor is referred to as a voltage drop. A German physicist, Kirchhoff, formulated a law which states *the sum of the voltage drops across the resistances of a closed circuit equals the total voltage applied to the circuit*. In the following illustration, four equal value resistors of 1.5 Ω each have been placed in series with a 12 volt battery. Ohm's Law can be applied to show that each resistor will "drop" an equal amount of voltage.

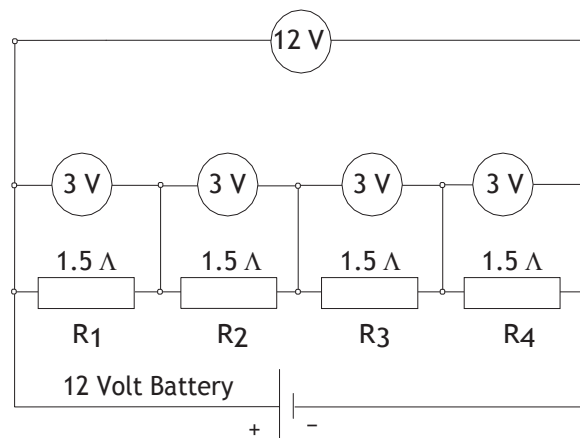

First, solve for total resistance:

$$\begin{aligned}R_t &= R_1 + R_2 + R_3 + R_4 \\R_t &= 1.5 + 1.5 + 1.5 + 1.5 \\R_t &= 6 \text{ } \Lambda\end{aligned}$$

Second, solve for current:

$$\begin{aligned}I &= \frac{E}{R} \\I &= \frac{12}{6} \\I &= 2 \text{ Amps}\end{aligned}$$

Third, solve for voltage across any resistor:

$$\begin{aligned}E &= I \times R \\E &= 2 \times 1.5 \\E &= 3 \text{ Volts}\end{aligned}$$

If voltage were measured across any single resistor, the meter would read three volts. If voltage were read across a combination of R_3 and R_4 the meter would read six volts. If voltage were read across a combination of R_2 , R_3 , and R_4 the meter would read nine volts. If the voltage drops of all four resistors were added together the sum would be 12 volts, the original supply voltage of the battery.

Voltage Division in a Series Circuit

It is often desirable to use a voltage potential that is lower than the supply voltage. To do this, a voltage divider, similar to the one illustrated, can be used. The battery represents E_{in} which in this case is 50 volts. The desired voltage is represented by E_{out} , which mathematically works out to be 40 volts. To calculate this voltage, first solve for total resistance.

$$\begin{aligned}R_t &= R_1 + R_2 \\R_t &= 5 + 20 \\R_t &= 25 \text{ } \Lambda\end{aligned}$$

Second, solve for current:

$$I = \frac{E_{in}}{R_t}$$

$$I = \frac{50}{25}$$

$$I = 2 \text{ Amps}$$

Finally, solve for voltage:

$$E_{out} = I \times R_2$$

$$E_{out} = 2 \times 20$$

$$E_{out} = 40 \text{ Volts}$$

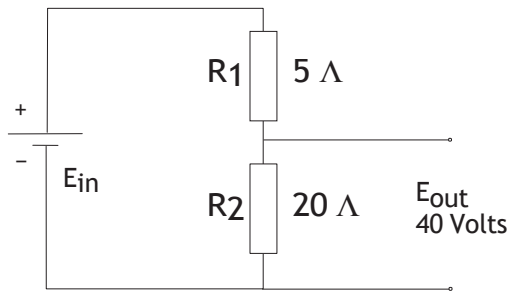

Review 3

1. The basic Ohm's Law formula is _____.
2. When solving circuit problems; current must always be expressed in _____, voltage must always be expressed in _____ and resistance must always be expressed in _____.
3. The total current of a simple circuit with a voltage supply of 12 volts and a resistance of 24Ω is _____ amps.
4. What is the total resistance of a series circuit with the following values: $R_1=10 \Omega$, $R_2=15 \Omega$, and $R_3=20 \Omega$? _____ Ω .
5. What is total current of a series circuit that has a 120 volt supply and 60Ω resistance?
6. In the following circuit the voltage dropped across R_1 is _____ volts and R_2 is _____ volts.

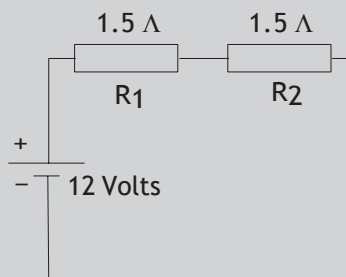

7. In the following circuit voltage dropped across R_1 is _____ volts, and R_2 is _____ volts.

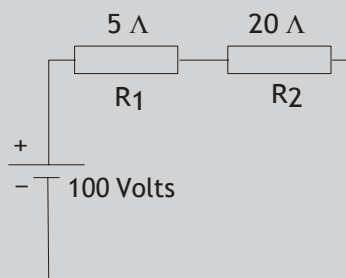

DC Parallel Circuit

Resistance in a Parallel Circuit

A parallel circuit is formed when two or more resistances are placed in a circuit side-by-side so that current can flow through more than one path. The illustration shows two resistors placed side-by-side. There are two paths of current flow. One path is from the negative terminal of the battery through R_1 returning to the positive terminal. The second path is from the negative terminal of the battery through R_2 returning to the positive terminal of the battery.

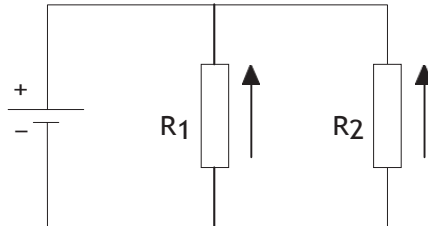

Formula for Equal Value Resistors in a Parallel Circuit

To determine the total resistance when resistors are of equal value in a parallel circuit, use the following formula:

$$R_t = \frac{\text{Value of any one Resistor}}{\text{Number of Resistors}}$$

In the following illustration there are three 15Ω resistors. The total resistance is:

$$R_t = \frac{\text{Value of any one Resistor}}{\text{Number of Resistor}}$$

$$R_t = \frac{15}{3}$$

$$R_t = 5 \Omega$$

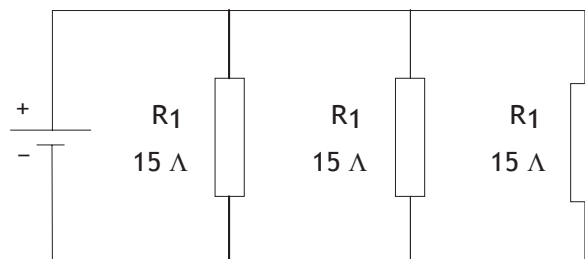

Formula for Unequal Resistors in a Parallel Circuit

There are two formulas to determine total resistance for unequal value resistors in a parallel circuit. The first formula is used when there are three or more resistors. The formula can be extended for any number of resistors.

$$\frac{1}{R_t} = \frac{1}{R_1} + \frac{1}{R_2} + \frac{1}{R_3}$$

In the following illustration there are three resistors, each of different value. The total resistance is:

$$\frac{1}{R_t} = \frac{1}{R_1} + \frac{1}{R_2} + \frac{1}{R_3}$$

$$\frac{1}{R_t} = \frac{1}{5} + \frac{1}{10} + \frac{1}{20} \quad \text{Insert Value of the Resistors}$$

$$\frac{1}{R_t} = \frac{4}{20} + \frac{2}{20} + \frac{1}{20} \quad \text{Find Lowest Common Denominator}$$

$$\frac{1}{R_t} = \frac{7}{20} \quad \text{Add the Numerators}$$

$$\frac{R_t}{1} = \frac{20}{7} \quad \text{Invert Both Sides of the Equation}$$

$$R_t = 2.86 \, \Omega \quad \text{Divide}$$

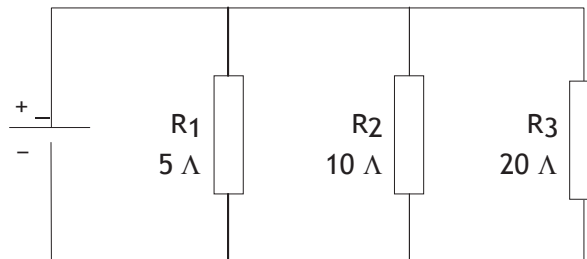

The second formula is used when there are only two resistors.

$$R_t = \frac{R_1 \times R_2}{R_1 + R_2}$$

In the following illustration there are two resistors, each of different value. The total resistance is:

$$R_t = \frac{R_1 \times R_2}{R_1 + R_2}$$

$$R_t = \frac{5 \times 10}{5 + 10}$$

$$R_t = \frac{50}{15}$$

$$R_t = 3.33 \ \Omega$$

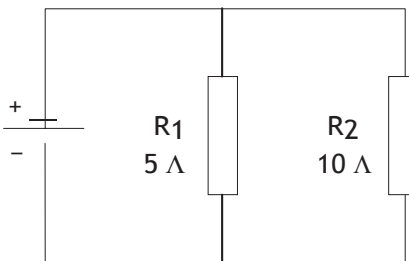

Voltage in a Parallel Circuit

When resistors are placed in parallel across a voltage source, the voltage is the same across each resistor. In the following illustration three resistors are placed in parallel across a 12 volt battery. Each resistor has 12 volts available to it.

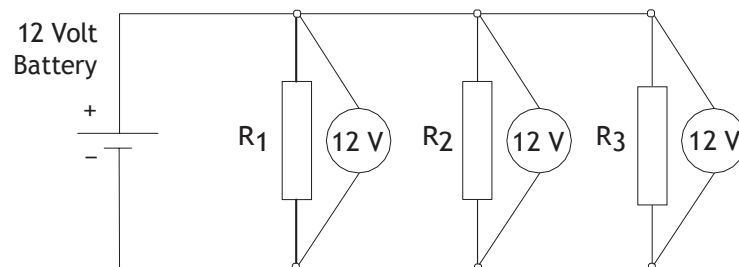

Current in a Parallel Circuit

Current flowing through a parallel circuit divides and flows through each branch of the circuit.

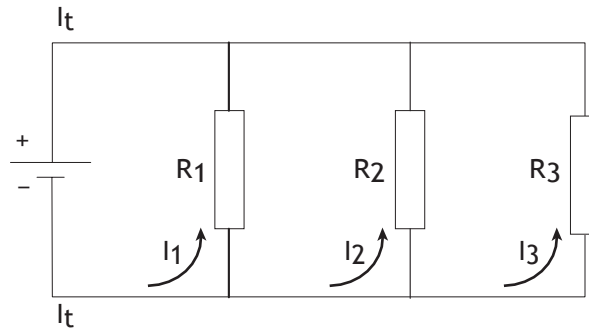

Total current in a parallel circuit is equal to the sum of the current in each branch. The following formula applies to current in a parallel circuit.

$$I_t = I_1 + I_2 + I_3$$

Current Flow with Equal Value Resistors in a Parallel Circuit

When equal resistances are placed in a parallel circuit, opposition to current flow is the same in each branch. In the following circuit R_1 and R_2 are of equal value. If total current (I_t) is 10 amps, then 5 amps would flow through R_1 and 5 amps would flow through R_2 .

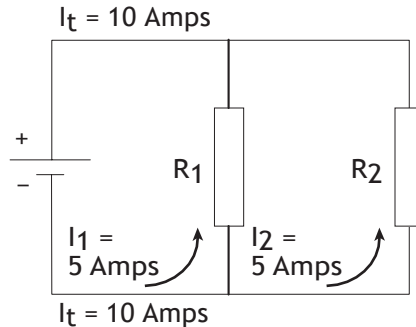

$$I_t = I_1 + I_2$$
$$I_t = 5 \text{ Amps} + 5 \text{ Amps}$$
$$I_t = 10 \text{ Amps}$$

Current Flow with Unequal Value Resistors in a Parallel Circuit

When unequal value resistors are placed in a parallel circuit, opposition to current flow is not the same in every circuit branch. Current is greater through the path of least resistance. In the following circuit R_1 is 40Ω and R_2 is 20Ω . Small values of resistance means less opposition to current flow. More current will flow through R_2 than R_1 .

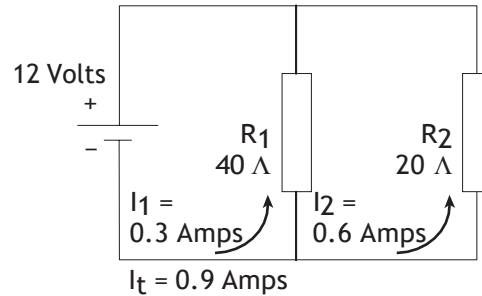

Using Ohm's Law, the total current for each circuit can be calculated.

$$I_1 = \frac{E}{R_1}$$

$$I_1 = \frac{120 \text{ Volts}}{40 \Omega}$$

$$I_1 = 0.3 \text{ Amps}$$

$$I_2 = \frac{E}{R_2}$$

$$I_2 = \frac{120 \text{ Volts}}{20 \Omega}$$

$$I_2 = 0.6 \text{ Amps}$$

$$I_t = I_1 + I_2$$

$$I_t = 0.3 \text{ Amps} + 0.6 \text{ Amps}$$

$$I_t = 0.9 \text{ Amps}$$

Total current can also be calculated by first calculating total resistance, then applying the formula for Ohm's Law.

$$R_t = \frac{R_1 \times R_2}{R_1 + R_2}$$

$$R_t = \frac{40 \, \Omega \times 20 \, \Omega}{40 \, \Omega + 20 \, \Omega}$$

$$R_t = \frac{800 \, \Omega}{60 \, \Omega}$$

$$R_t = 13.333 \, \Omega$$

$$I_t = \frac{E}{R_t}$$

$$I_t = \frac{12 \, \text{Volts}}{13.333 \, \Omega}$$

$$I_t = 0.9 \, \text{Amps}$$

Review 4

1. The total resistance of a parallel circuit that has four 20Ω resistors is _____ Ω .

2. R_t for the following circuit is _____ Ω .

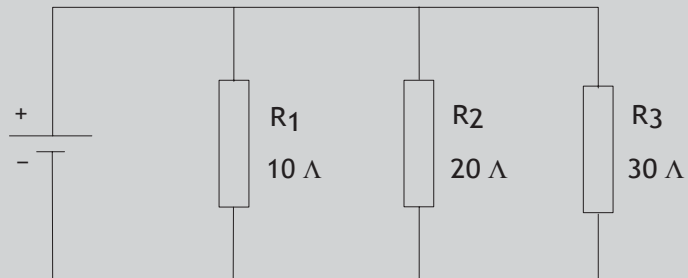

3. R_t for the following circuit is _____ Ω .

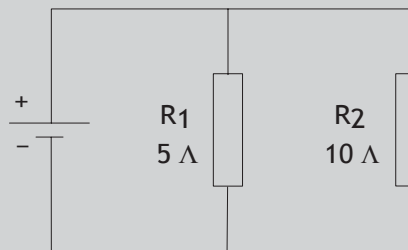

4. Voltage available at R_2 in the following circuit is _____ volts.

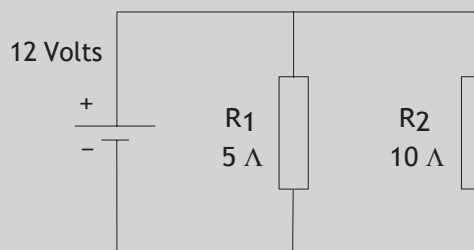

5. In a parallel circuit with two resistors of equal value and a total current flow of 12 amps, the value of current through each resistor is _____ amps.

6. In the following circuit current flow through R_1 is _____ amps, and R_2 is _____ amps.

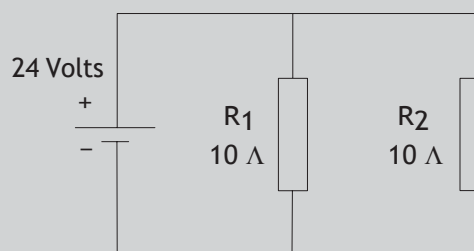

Series-Parallel Circuits

Series-parallel circuits are also known as compound circuits. At least three resistors are required to form a series-parallel circuit. The following illustrations show two ways a series-parallel combination could be found.

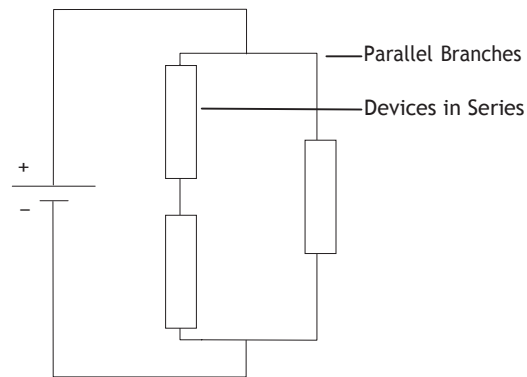
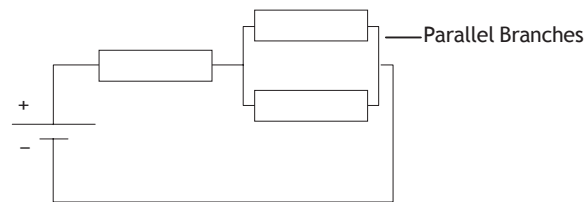

Simplifying a Series-Parallel

The formulas required for solving current, voltage and resistance problems have already been defined. To solve a series-parallel circuit, reduce the compound circuits to equivalent simple circuits. In the following illustration R_1 and R_2 are parallel with each other. R_3 is in series with the parallel circuit of R_1 and R_2 .

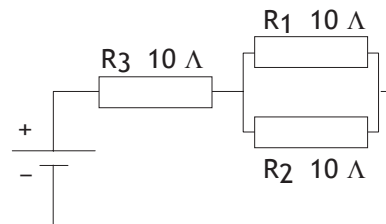

First, use the formula to determine total resistance of a parallel circuit to find the total resistance of R_1 and R_2 . When the resistors in a parallel circuit are equal, the following formula is used:

$$R = \frac{\text{Value of any One Resistor}}{\text{Number of Resistors}}$$

$$R = \frac{10 \Omega}{2}$$

$$R = 5 \Omega$$

Second, redraw the circuit showing the equivalent values. The result is a simple series circuit which uses already learned equations and methods of problem solving.

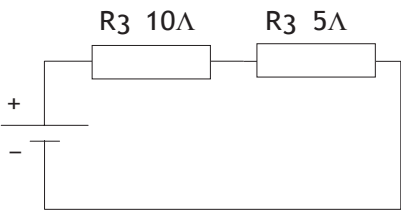

Simplifying a Series-Parallel Circuit to a Parallel Circuit

In the following illustration R_1 and R_2 are in series with each other. R_3 is in parallel with the series circuit of R_1 and R_2 .

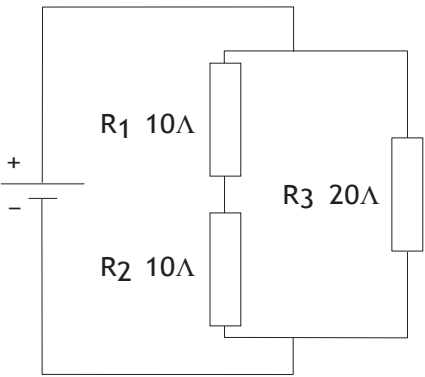

First, use the formula to determine total resistance of a series circuit to find the total resistance of R_1 and R_2 . The following formula is used:

$$R = R_1 + R_2$$

$$R = 10 \Omega + 10 \Omega$$

$$R = 20 \Omega$$

Second, redraw the circuit showing the equivalent values. The result is a simple parallel circuit which uses already learned equations and methods of problem solving.

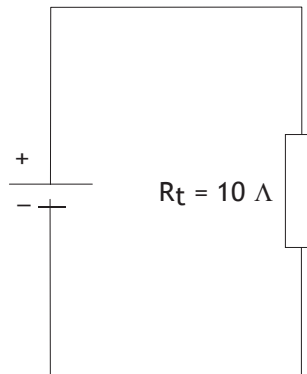
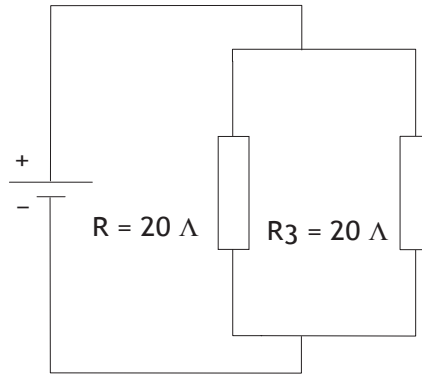

Review 5

1. Calculate equivalent resistance for R_1 and R_2 and total resistance for the entire circuit.

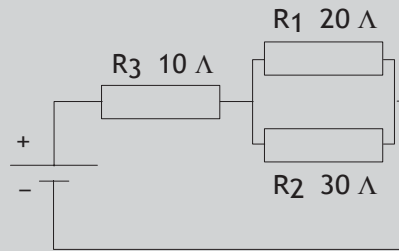

R_1/R_2 equivalent resistance = _____ Ω

Total resistance = _____ Ω

2. Calculate equivalent resistance for R_1 and R_2 and total resistance for the entire circuit.

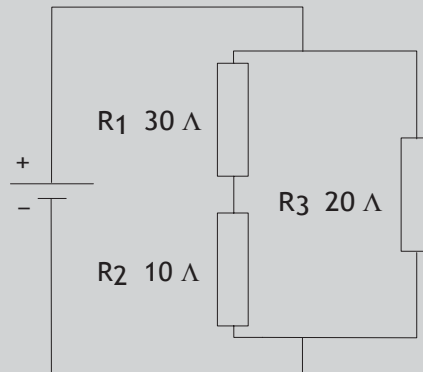

R_1/R_2 equivalent resistance = _____ Ω

Total resistance = _____ Ω

Power

Work

Whenever a force of any kind causes motion, work is accomplished. In the illustration below work is done when a mechanical force is used to lift a weight. If a force were exerted without causing motion, then no work is done.

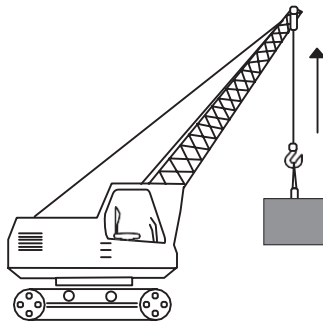

Electric Power

In an electrical circuit, voltage applied to a conductor will cause electrons to flow. Voltage is the force and electron flow is the motion. The rate at which work is done is called power and is represented by the symbol “P.” Power is measured in watts and is represented by the symbol “W.” The watt is defined as *the rate work is done in a circuit when 1 amp flows with 1 volt applied.*

Power Formulas

Power consumed in a resistor depends on the amount of current that passes through the resistor for a given voltage. This is expressed as voltage times current.

$$P = E \times I$$

or

$$P = EI$$

Power can also be calculated by substituting other components of Ohm’s Law.

$$P = I^2R$$

and

$$P = \frac{E^2}{R}$$

Solving a Power Problem

In the following illustration power can be calculated using any of the power formulas.

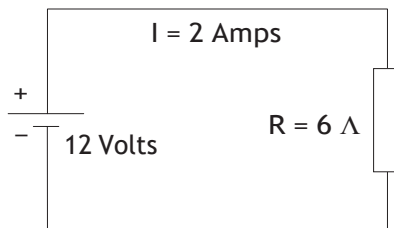

$$P = EI$$
$$P = 12 \text{ Volts} \times 2 \text{ Amps}$$
$$P = 24 \text{ Watts}$$

$$P = I^2R$$
$$P = (2 \text{ Amps})^2 \times 6 \Omega$$
$$P = 24 \text{ Watts}$$

$$P = \frac{E^2}{R}$$

$$P = \frac{(12 \text{ Volts})^2}{6 \Omega}$$

$$P = \frac{144}{6}$$

$$P = 24 \text{ Watts}$$

Power Rating of Equipment

Electrical equipment is rated in watts. This rating is an indication of the rate at which electrical equipment converts electrical energy into other forms of energy, such as heat or light. A common household lamp may be rated for 120 volts and 100 watts. Using Ohm's Law, the rated value of resistance of the lamp can be calculated.

$$P = \frac{E^2}{R} \text{ which can be transposed to } R = \frac{E^2}{P}$$

$$R = \frac{(120 \text{ Volts})^2}{100 \text{ Watts}}$$

$$R = 144 \Omega$$

Using the basic Ohm's Law formula, the amount of current flow for the 120 volt, 100 watt lamp can be calculated.

$$I = \frac{E}{R}$$

$$I = \frac{120 \text{ Volts}}{144 \text{ } \Omega}$$

$$I = 0.833 \text{ Amps}$$

A lamp rated for 120 volts and 75 watts has a resistance of 192 Ω and a current of 0.625 amps would flow if the lamp had the rated voltage applied to it.

$$R = \frac{E^2}{P}$$

$$R = \frac{(120 \text{ Volts})^2}{75 \text{ Watts}}$$

$$R = 192 \text{ } \Omega$$

$$I = \frac{E^2}{P}$$

$$I = \frac{120 \text{ Volts}}{192 \text{ } \Omega}$$

$$I = 0.625 \text{ Amps}$$

It can be seen that the 100 watt lamp converts energy faster than the 75 watt lamp. The 100 watt lamp will give off more light and heat.

Heat

Current flow through a resistive material causes heat. An electrical component can be damaged if the temperature is too high. For this reason, electrical equipment is often rated for a maximum wattage. The higher the wattage rating, the more heat the equipment can dissipate.

Magnetism

The principles of magnetism are an integral part of electricity. Electromagnets are used in some direct current circuits. Alternating current cannot be understood without first understanding magnetism.

Types of Magnets

The three most common forms of magnets are the horse-shoe, bar and compass needle.

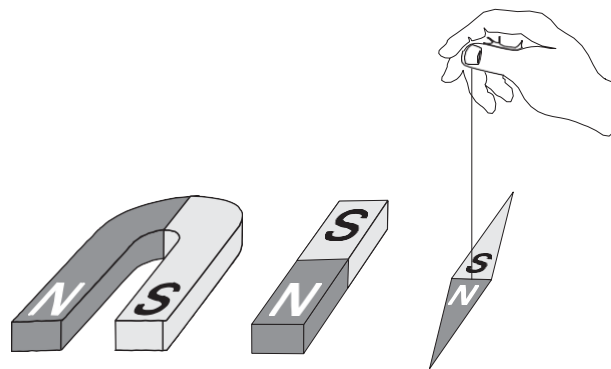

All magnets have two characteristics. They attract and hold iron. If free to move, like the compass needle, the magnet will assume roughly a north-south position.

Magnetic Lines of Flux

Every magnet has two poles, one north pole and one south pole. Invisible magnetic lines of flux leave the north pole and enter the south pole. While the lines of flux are invisible, the effects of magnetic fields can be made visible. When a sheet of paper is placed on a magnet and iron filings loosely scattered over it, the filings will arrange themselves along the invisible lines of flux.

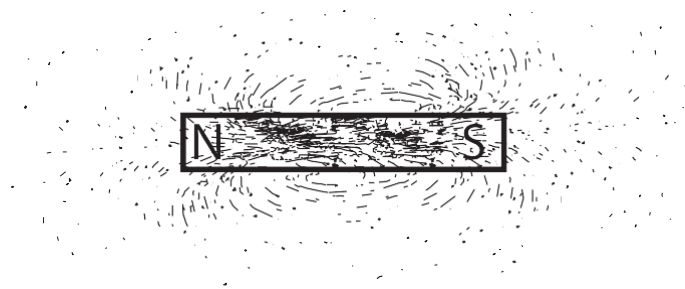

By drawing lines the way the iron filings have arranged themselves, the following picture is obtained. Broken lines indicate the paths of magnetic flux lines. The field lines exist outside and inside the magnet. The magnetic lines of flux always form closed loops. Magnetic lines of flux leave the north pole and enter the south pole, returning to the north pole through the magnet.

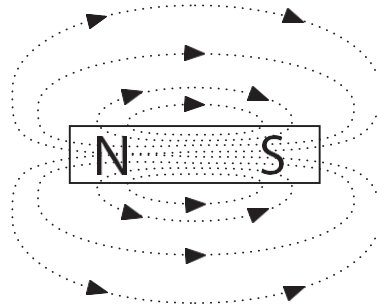

Interaction between Two Magnets

When two magnets are brought together, the magnetic flux field around the magnet causes some form of interaction. Two unlike poles brought together cause the magnets to attract each other. Two like poles brought together cause the magnets to repel each other.

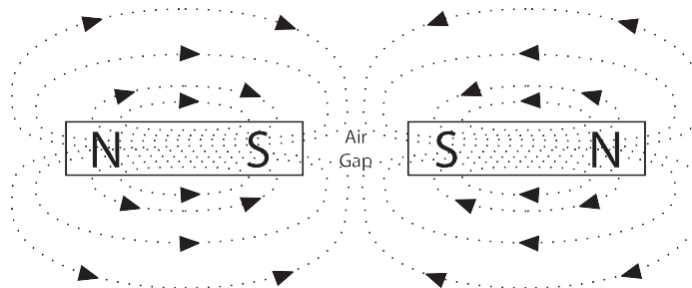
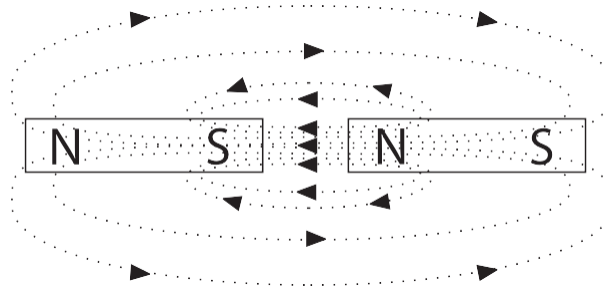

Electromagnetism

Left-Hand Rule for Conductors

An electromagnetic field is a magnetic field generated by current flow in a conductor. Whenever current flows a magnetic field exists around the conductor. Every electric current generates a magnetic field. A definite relationship exists between the direction of current flow and the direction of the magnetic field. The left-hand rule for conductors demonstrates this relationship. If a current-carrying conductor is grasped with the left hand with the thumb pointing in the direction of electron flow, the fingers will point in the direction of the magnetic lines of flux.

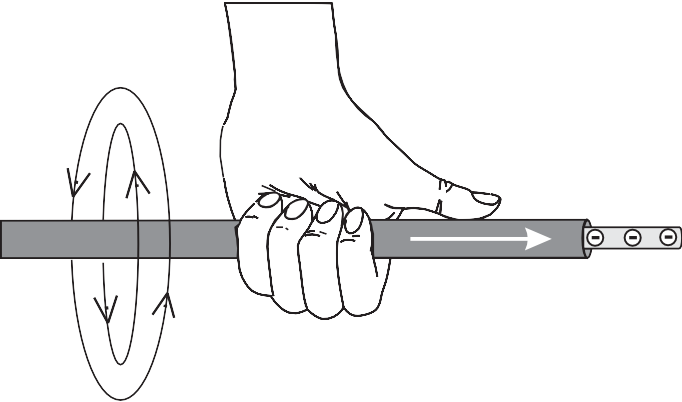

Current-Carrying Coil

A coil of wire carrying a current, acts like a magnet. Individual loops of wire act as small magnets. The individual fields add together to form one magnet. The strength of the field can be increased by adding more turns to the coil. The strength can also be increased by increasing the current.

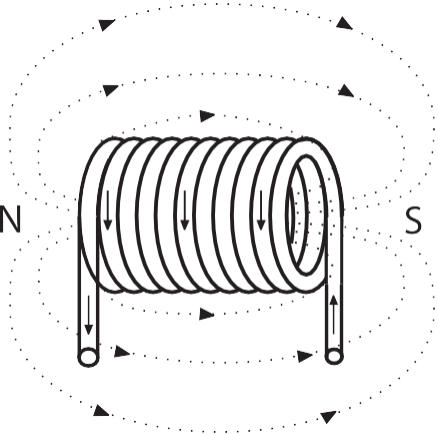

Left-Hand Rule for Coils

A left-hand rule exists for coils to determine the direction of the magnetic field. The fingers of the left hand are wrapped around the coil in the direction of electron flow. The thumb points to the north pole of the coil.

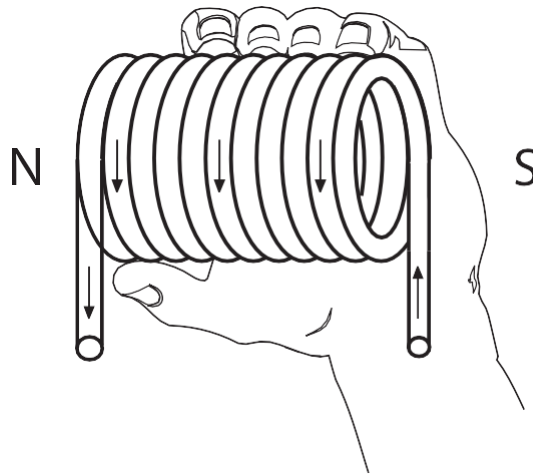

Electromagnets

An electromagnet is composed of a coil of wire wound around a core. The core is usually a soft iron which conducts magnetic lines of force with relative ease. When current is passed through the coil, the core becomes magnetized. The ability to control the strength and direction of the magnetic force makes electromagnets useful. As with permanent magnets, opposite poles attract. An electromagnet can be made to control the strength of its field which controls the strength of the magnetic poles.

A large variety of electrical devices such as motors, circuit breakers, contactors, relays and motor starters use electromagnetic principles.

Review 6

1. The rate at which work is done is called _____ .
2. The basic formula for power is_____.
3. In a circuit with a 12 volt supply and 4 Ω resistance the power consumed is_____watts.
4. The two characteristics of all magnets are; they attract and hold_____, and if free to move will assume roughly a_____position.
5. Lines of flux always leave the_____pole and enter the_____pole.
6. The left-hand rule for conductors states that when the_____hand is placed on a current-carrying conductor with the_____pointing in the direction of electron flow, the fingers will point in the direction of_____.

Introduction to AC

The supply of current for electrical devices may come from a direct current source (DC), or an alternating current source (AC). In direct current electricity, electrons flow continuously in one direction from the source of power through a conductor to a load and back to the source of power. Voltage in direct current remains constant. DC power sources include batteries and DC generators. In allowing current an AC generator is used to make electrons flow first in one direction then in another. Another name for an AC generator is an alternator. The AC generator reverses terminal polarity many times a second. Electrons will flow through a conductor from the negative terminal to the positive terminal, first in one direction then another.

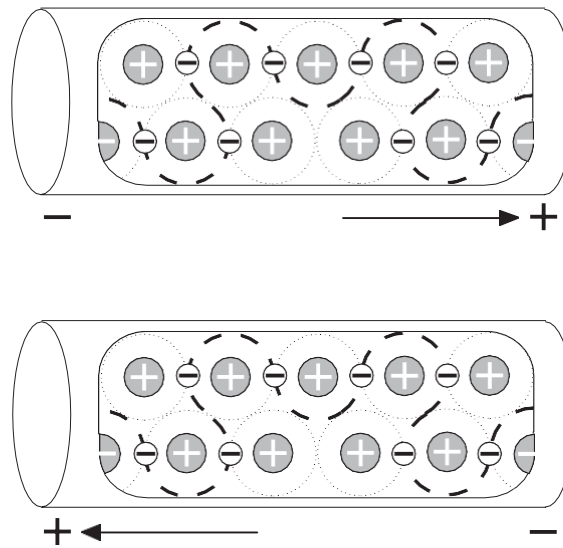

AC Sine Wave

Alternating voltage and current vary continuously. The graphic representation for AC is a sine wave. A sine wave can represent current or voltage. There are two axes. The vertical axis represents the direction and magnitude of current or voltage. The horizontal axis represents time.

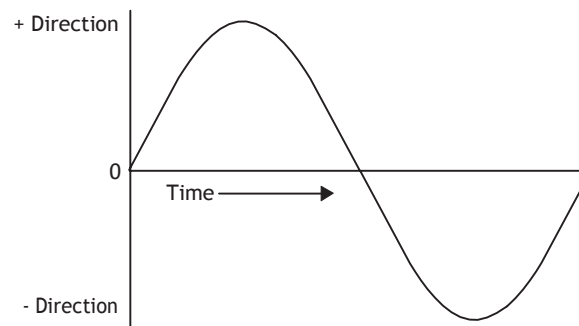

When the waveform is above the time axis, current is flowing in one direction. This is referred to as the positive direction. When the waveform is below the time axis, current is flowing in the opposite direction. This is referred to as the negative direction. A sine wave moves through a complete rotation of 360 degrees, which is referred to as one cycle. Alternating current goes through many of these cycles each second. The unit of measurement of cycles per second is hertz. In the United States alternating current is usually generated at 60 hertz.

Single-Phase and Three-Phase AC Power

Alternating current is divided into single-phase and three-phase types. Single-phase power is used for small electrical demands such as found in the home. Three-phase power is used where large blocks of power are required, such as found in commercial applications and industrial plants. Single-phase power is shown in the above illustration. Three-phase power, as shown in the following illustration, is a continuous series of three overlapping AC cycles. Each wave represents a phase, and is offset by 120 electrical degrees.

