



The Special Theory of Relativity

Dr. Nasr Eldien Faried Elansary

Faculty of Science
South Valley University

بِسْمِ اللَّهِ الرَّحْمَنِ الرَّحِيمِ

فَلْيَسِّرْ لَنَا مَنَاسِكَ الْفَرَائِدِ وَالْعُرْجِ جَمًّا

صَدَقَ اللَّهُ الْعَظِيمَ

بِسْمِ اللَّهِ الرَّحْمَنِ الرَّحِيمِ

لَا تَجْعَلْ مَعِيَ الْعِلْمَ وَالْحِلْمَ

صَدَقَ اللَّهُ الْعَظِيمَ

رؤية الكلية

التميز فى العلوم الأساسية والبحث العلمى للمساهمة فى التنمية
المستدامة

رسالة الكلية

تقديم تعليم مميز فى مجالات العلوم الاساسية وإنتاج بحوث علمية
تطبيقية للمساهمة فى التنمية المستدامة من خلال إعداد خريجين
متميزين طبقاً للمعايير الأكاديمية القومية ، وتطوير مهارات وقدرات
الموارد البشرية وتوفير خدمات مجتمعية وبيئية تلبى طموحات مجتمع
جنوب الوادى ، وبناء الشراكات المجتمعية الفاعلة.

Contents

INTRODUCTION -----	1
CHAPTER ONE -----	3
REFERENCE FRAME-----	3
NEWTON'S LAWS OF MOTION-----	4
<i>The first law:</i> -----	4
<i>The second law</i> -----	4
<i>The third law</i> -----	5
ABSOLUTE TIME-----	5
THE PRINCIPLE OF SYMMETRY OF OBSERVERS - GALILEO TRANSFORMATION-----	7
RESULT-----	8
NEWTON'S LAW OF GENERAL ATTRACTION-----	9
THE ELECTROMAGNETIC THEORY OF LIGHT-----	9
SYNCHRONIZATION OF DISTANT CLOCKS-----	10
SCIENTIFIC CONTRADICTIONS IN CLASSICAL PHYSICS-----	12
<i>Fizeau & Fresnel experiment</i> -----	12
<i>Michelson & Morely experiment</i> -----	12
SCIENTISTS' ATTEMPTS TO EXPLAIN PREVIOUS RESULTS-----	14
<i>Ether Drag assumption</i> -----	14
<i>Fitzgeald-Lorentz assumption</i> -----	15
THE SCIENTIFIC IDEAS THAT PAVED THE WAY FOR THE THEORY OF SPECIAL RELATIVITY-----	15
<i>Lorentz's theory</i> -----	15
<i>Poincare Ideas</i> -----	16
CHAPTER TWO -----	17
THE POSTULATES OF SPECIAL RELATIVITY-----	17
<i>The first postulate</i> -----	17
<i>The second postulate</i> -----	17
THE LORENTZ TRANSFORMATION-----	17
SETTING THE SPACED CLOCKS-----	21
PROPERTIES OF LORENTZ TRANSFORMATION-----	21

PROPERTIES OF LORENTZ TRANSFORMATION-----	23
<i>Fitzgerald - Lorentz contraction</i> -----	23
<i>Simultaneity of events</i> -----	24
<i>Time dilatation</i> -----	25
<i>Velocity transformations</i> -----	25
IMPORTANT PROPERTY OF THE LORENTZ TRANSFORMATION-----	27
CLOCK PARADOX-----	31
PROBLEMS -----	33
CHAPTER THREE -----	34
THE 4 – DIMENSIONAL SPACE-TIME OF MINKOWSKI-----	34
WORLD LINE OF A PARTICLE-----	36
<i>World line of a static particle</i> -----	36
<i>World line of a moving particle</i> -----	36
GEOMETRIC REPRESENTATION OF KINEMATIC PHENOMENA-----	37
<i>Fitzgerald and Lorentz contraction</i> -----	37
<i>Simultaneity of events</i> -----	38
<i>Time dilatation</i> -----	39
PROPER TIME-----	40
LIGHT CONE-----	41

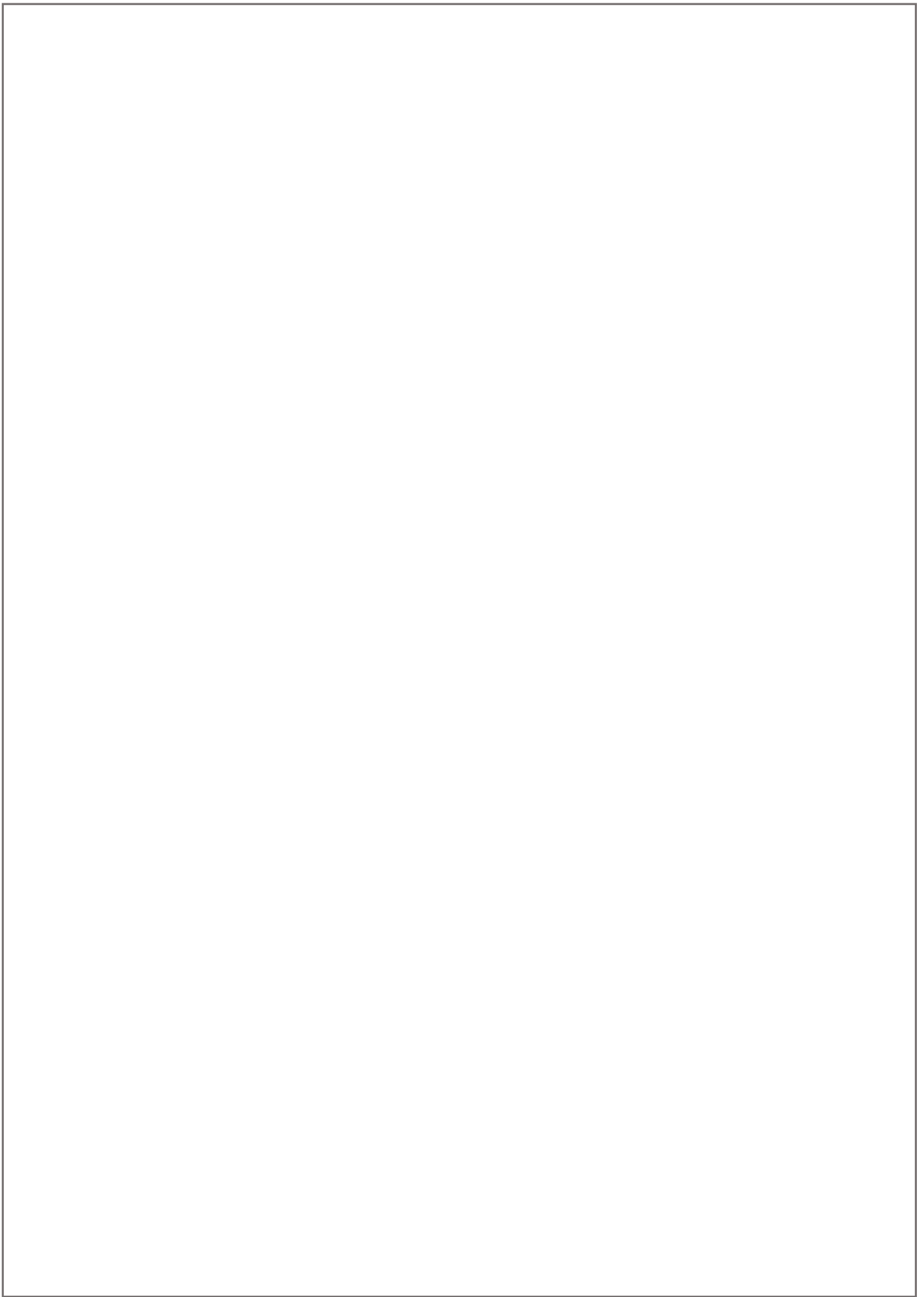

Introduction

The different branches of theoretical physics are concerned with the study of all physical phenomena that occur in the universe. These phenomena consist of a group of mechanical phenomena that relate to the states of static and movement of physical bodies under the influence of natural forces, and electromagnetic phenomena that consist of electric and magnetic fields that arise from the presence of static or moving electrical charges that generate light radiation from them. The many in the form of waves that propagate and interact with matter, and besides that there are other phenomena that occur in the range of the atom and its components. To understand these phenomena, the human mind resorts to science, which depends mainly on experience, and the method of science is to make certain models stemming from experience and experience that a person touches when he observes a certain type of phenomena. In the model, the mind names some things and knows other things, and then uses these concepts to put his experimental notes in the form of principles and laws, and he may add to this assumptions from his creations.

In most of these models mathematics with its laws and mathematical logic plays a constructive role. Theories are based on this basis using the rules of logic, and their correctness or error is judged by experience. Until the late nineteenth century, mechanical phenomena and the phenomena of gravity were interpreted in a very satisfactory manner using Newton's laws of motion and Newton's law of general attraction, which led scientists to believe that the mental framework of these laws is the correct and appropriate framework for describing all physical phenomena. At the same time (in 1864 A.D.) Maxwell's electromagnetic theory appeared, which was successful when explaining electric and magnetic phenomena and considering light to be electromagnetic waves. It was possible that the path of science based on Newton's laws in classical mechanics, and Maxwell's theory of electromagnetic fields lined with wreaths of success, especially after the great technological progress and the success of celestial mechanics in discovering new planets. Except that some contradictions and questions arose when scientists attempted to link the laws of classical mechanics with electromagnetic theory to explain some common phenomena. This link stems from the (false) belief that the mental framework of Newton's laws is the correct framework for building

physical theories. Here it was the collision of basic concepts, the beginning of thinking to revisit classical physics, which resulted in the emergence of new ideas and modern science. Among the recent theories that have resulted from this collision:

The Theory of Relativity developed by the scientist Albert Einstein between 1905 and 1917 AD and is in two parts: The first part is called the theory of special relativity **The Special (Restricted) Theory of Relativity** it was developed in 1905, and it is the subject of our studies in these lectures. The second part is called The General Theory of Relativity and takes into account the fields of gravitation. In the first section, we will try to clarify the questions in classical physics that led to the emergence of relativity.

Since ancient times, scholars and philosophers have spoken of relativistic knowledge and relativistic movement. And "Newton" was aware of the relativistic movement, until he announced in 1687 what he called "the principle of relativity to Newton", which is: "Does the movement of objects in relation to one another in a framework (ie somewhere: a train or other) change if this framework moves?" Which contains the objects a regular movement after he was still. " As for the theory of relativity, it searches for laws that explain physical phenomena, and are not affected by time, space and conditions.

Chapter One

Pre-Relativity Physics

Chapter One

Pre-Relativity Physics

1. Reference Frame

Physical phenomena are events that occur at a specific location and time. In order to measure these events and formulate the laws that govern them, we need an accurate hour to know the time of their occurrence and space engineering that enables us to determine their locations and the distances between these events. In the mathematical model, the event represents with a geometrical point whose location is determined by measuring its dimensions (Coordinates) from three planes called the basic planes, as it is called the lines of its intersection with the basic axes. The main set of axes, in addition to the clock, is known as a reference frame, and it is denoted by the symbol S .

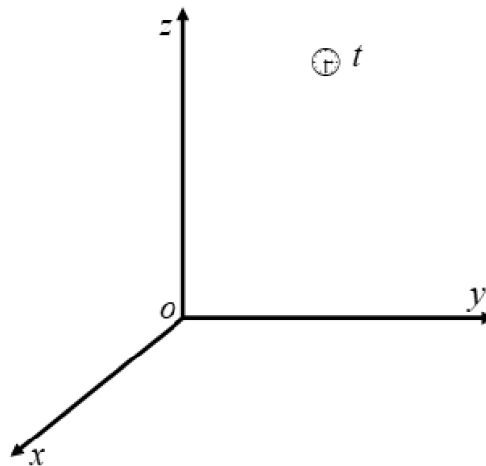

Fig. (1)

Where the spatial coordinates are: (x, y, z) And time is t form fig.(1) as the name of the observer is called for those who make the observations and measurements in this frame, and it is symbolized by the symbol A . There is an infinite number of correlative frames that are suitable for measuring physical phenomena, and usually the observer chooses the affiliate frame that is consistent with his mechanical state.).

We will symbolize these animated frames as $S'' , S' \dots\dots\dots$

Where the spatial coordinates are: $(x'' , y'' , z'') , (x' , y' , z') \cdot$ The corresponding times are $t'' , t' \cdot \dots$ and so on $\dots\dots\dots$

In order to relate the results to the measurements obtained by the observers **A, B, C**..... each in its affiliation frame, we need a relationship between the coordinates:

(x, y, z) and time t , and coordinates (x', y', z') and time t' , and coordinates (x'', y'', z'') and time t'' ,

This relationship is called a transformation, and transformations play an important role in the formulation of physical laws, as it is through them that the frameworks of affiliation can be chosen in which the physical law takes its simplest form.

2. Newton's laws of motion:

Newton assumed the existence of an affiliate frame preferable to others, and all phenomena can be measured from static or movement with respect to it, and it is called the Absolute Frame: Newton formulated his three known laws regarding the absolute frame. If we code for this frame **S**, then Newton's laws take the formula:

The first law:

If the force \vec{F} acting on a particle is null, then it is moving at a regular velocity \vec{v}_0 in a straight line, i.e if: $\vec{F} = \vec{0}$ then:

$$\vec{v} = \frac{d\vec{r}}{dt} = \vec{v}_0 \quad (1)$$

Where \vec{r} the position vector of the particle, t time is measured with respect to the absolute frame, so the path of the particle is as:

$$\vec{r} = \vec{r}_0 + \vec{v}_0 t \quad (2)$$

This is the equation of a straight line in the vector form.

The second law:

If a force \vec{F} acts on a particle of mass m , it moves with acceleration \vec{a} as:

$$\vec{F} = m \vec{a} = m \frac{d^2 \vec{r}}{dt^2} \quad (3)$$

The path of the particle depends on the form of the force \vec{F} , i.e. the form of the law of force.

The third law:

Every action has a reaction of equal magnitude and opposite to it in direction.

If it \vec{F}_{12} is the force that body 1 acts on body 2, \vec{F}_{21} that which body 2 acts on body 1 at the same moment, then:

$$\vec{F}_{12} = - \vec{F}_{21} \quad (4)$$

This law means that if the two bodies are far apart, then each of them is affected by the other at the same moment, meaning that the influence of the forces is instantaneous.

3. Absolute Time:

From Newton's first law, we find that if the force acting on a particle vanishes, the particle's path measured with respect to the frame \mathcal{S} is a straight line. If we consider another frame \mathcal{S}' moving at a uniform velocity \vec{V} in a straight line with respect to the frame \mathcal{S} , we find that the particle is moving with respect \mathcal{S}' at regular velocity \vec{v}' , which is given by the formula:

$$\vec{v}' = \vec{v} - \vec{V} \quad (5)$$

Where \vec{v} the velocity of the particle is with respect to \mathcal{S} . If \vec{r}' is the vector of the position of the particle with respect to the frame \mathcal{S}' then:

$$\frac{d\vec{r}'}{dt'} = \vec{v} - \vec{V} \quad (6)$$

Where t' the time measured with respect to \mathcal{S}' , and by substituting \vec{v} from equation (1) into equation (6):

$$\frac{d\vec{r}'}{dt'} = \vec{v}_0 - \vec{V} \quad (7)$$

By integrating with respect to time: t' we find that:

$$\vec{r}' = (\vec{v}_0 - \vec{V}) t' + \vec{r}'_0 \quad (8)$$

Where \vec{r}'_0 is the position of the particle at the moment: $t' = 0$ Equation (8) is the equation of the path of the particle if it is observed by the observer \mathcal{B} in the frame \mathcal{S}' , but \mathcal{B} he also notices that the particle is not

under the influence of a force, so its path must be a straight line with respect to it. Assuming that the two frames S, S' apply when: $t' = t = 0$ it is $\vec{r}'_o = \vec{r}_o$ also produced - from fig. (2). That:

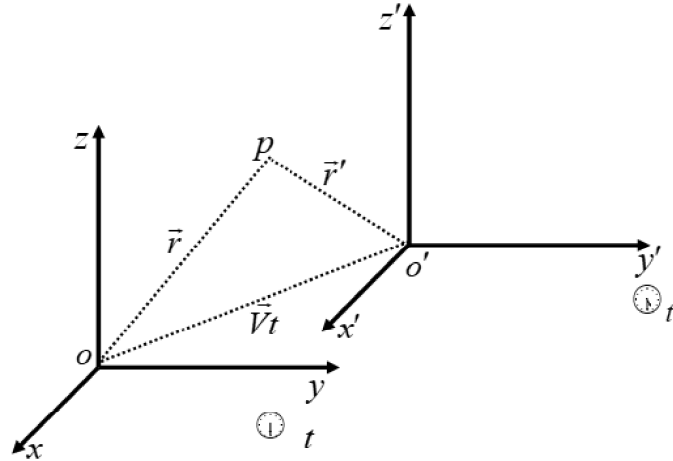

Fig. (2)

$$\vec{r}' = \vec{r} - \vec{V}t = (\vec{v}_o - \vec{V})t + \vec{r}_o \tag{9}$$

In comparison with equation (8), we find that:

$$t = t' \tag{10}$$

Condition (10) means that time is absolute and does not depend on the enrollment framework measured against it. We conclude from this - assuming that time is absolute - that if Newton's first law applies in the frame S , then it also applies in S' reality. There is a set of proportional frames that move relative to each other at a regular velocity in a straight line, and in each of them Newton's first law applies. These frames are called **inertial frames**, and they play a large role in physical laws. These frames can be considered a substitute for the absolute frame imposed by Newton, and he recently called them "the alpha particles"

4. The principle of symmetry of observers - Galileo

Transformation:

The physical phenomena that occur in the universe are completely independent of the observer who observes them. If the observer **A** finds that the path of a particle is a straight line and deduces from this that the particle is not under the influence of a force, then the observer **B**- who moves at a uniform velocity in a straight line with respect to the observer **A** - must find that as well.

It is expressed that the observers in inertial frames are the same or equivalent to describe physical phenomena. All the difference between them is that they use different symbols, but the form of the law that governs the physical phenomenon they reach is one.

The relationship between measurements of the observers in inertial frames can be found by transformations. Assume that the frame **S'** moves with respect to the a frame **S** at a regular velocity \vec{V} in a straight line - Figure (2) – if \vec{r}, \vec{r}' are the two locations of the event **p** at the two times t, t' , with respect to each of **S, S'**, then:

$$\begin{aligned} t' &= t \quad , \\ \vec{r}' &= \vec{r} - \vec{V} t \quad . \end{aligned} \quad (11)$$

The two equations (11) are known as the Galileo transformation. This transformation is the basis on which classical mechanics are built. Under this transformation, which links the measurements of each of the observers **A, B** to each other, we find that Newton's second law preserves its form, so if we assume that the form of this law in relation to the observer **A** is:

$$m \frac{d^2 \vec{r}}{dt^2} = \vec{F} \quad .$$

For what is observed **B** is:

$$\frac{d^2\vec{r}'}{dt^2} = \frac{d^2}{dt^2}(\vec{r} - \vec{V}t) = \frac{d^2\vec{r}}{dt^2} . \quad (12)$$

This is because a \vec{V} vector is constant.

If we denote the measured force with respect to the observer **B** symbol \vec{F}' , then:

$$\vec{F}' = m \frac{d^2\vec{r}'}{dt'^2} = m \frac{d^2\vec{r}}{dt^2} = \vec{F} . \quad (13)$$

This means that Newton's laws are "invariant in form" under Galileo transformation. That is observers **A**, **B** obtain the same form of laws in the language of the affiliated frameworks to which they belong. This is called the principle of relativity of Galileo. It is noticed that in the last step of equation (13) we assumed - with Newton - that:

$$m = m' \quad (14)$$

That is, the mass of a particle is absolute, not dependent on the frame measured with respect to it.

5. Result:

If we impose two events that are localized in relation to the frame **S** they are \vec{r}_1, \vec{r}_2 , at the same moment **t**, then their localization in relation to the frame **S'** are:

$$\vec{r}'_1 = \vec{r}_1 - \vec{V}t \quad , \quad \vec{r}'_2 = \vec{r}_2 - \vec{V}t .$$

Subtraction and quadrature we find that:

$$(\vec{r}'_1 - \vec{r}'_2)^2 = (\vec{r}_1 - \vec{r}_2)^2 . \quad (15)$$

That is, the distance between the two events remains "invariant in the form" under Galileo transformation, and this means that the measured

lengths are absolute. If we take the two events very close to each other, then (15) becomes:

$$\begin{aligned} (d\vec{r}')^2 &= (d\vec{r})^2 , \\ (dx')^2 + (dy')^2 + (dz')^2 &= (dx)^2 + (dy)^2 + (dz)^2 . \end{aligned} \quad (16)$$

This quadratic form is called "the square of the element of length in the Euclidean triple space" and is denoted by the symbol $(ds)^2$ where ds the element is length. It is known that vectors in the triple space (triple vectors) do not depend on choosing a specific affiliate frame, and it can also be shown that the scalar product of two vectors remains "invariant in the form" under Galileo information, and accordingly the laws governing physical phenomena in the triple space (It does not depend on the observer measuring it) it must be an absolute relationship.

6. Newton's Law of General Attraction:

It states that everything attracts everything. The force of attraction \vec{F} between two masses m_1, m_2 separated by a distance r is measured by the inverse square law:

$$\vec{F} = \gamma \frac{m_1 m_2}{r^3} \vec{r} . \quad (17)$$

According to this law, the planets revolve in constant elliptical paths around the sun, which is at one of their foci, but in 1882 the French astronomer *Louvriere* discovered that the path of Mercury is not fixed, but rather it rotates at a very small angle.

7. The electromagnetic theory of light:

Maxwell developed the equations known by his name, which link electrical and magnetic phenomena, and according to Maxwell's theory all radiation (especially light) appears as electromagnetic waves traveling at a constant speed in space equal to about 3×10^{10} cm / sec and usually denoted by the symbol c . As found - by observing Even stars - that the velocity of light does not depend on the velocity of the source that radiates the light waves, but with which correlational frame is the speed of light measured?

Waves generally need a physical medium for their propagation, and their velocity can be measured relative to the frame in which this material medium is static. For example, sound waves we find that the velocity of sound is measured in relation to the static air, and nineteenth century scientists proposed an invisible medium that fills all space and penetrates all materials and allows waves to travel. Electromagnetism as a carrier of it. The velocity of light relative to the frame in which the medium is static is c . This medium was named: *Ether*

Until the late nineteenth century, scientists were trying to attribute physical phenomena (and in particular electromagnetic phenomena) to mechanics, so all physical laws had to be "invariant in form" under Galileo transformation, which is the basis of the laws of classical mechanics. But the assumption of the existence of the *Ether* made it possible to distinguish an associative frame from other frames, which is in which the *Ether* is static, and this distinction makes Maxwell's equations "not invariant in form" under Galileo transformation. Here was the question: Can the imposition of the existence of the ether be dispensed with? And if so, what other transformations between inertial frames make Maxwell's equations "invariant in form"?

8. Synchronization of distant clocks:

To measure the multiple events in the universe, we assume the presence of an observer in an affiliate framework, and we assume that there is a group of observers distributed at different points in the triple space, and each of them is equipped with a clock, and these clocks are identical and read the same time when they are next to each other, that is, they are accurate. But what happens when the clocks run apart? Is it also correct? To verify this we attend one of the distant clocks and compare its reading to our reading.

Assuming absolute time, the readings must apply.

Another question is whether clocks read the same time when spaced apart. In another phrase, this question can be asked: When we say "now" in one place, is it also "now" in another place with respect to the same static frame S ?

In the classical nature we get the answer yes, that is, there is an absolute "Anne". But let us discuss the following ideal experiment: Suppose that we have two hours P , Q , set at the beginning - Fig. (3) - at the moment t_{1P} we let a light signal go from P to Q where

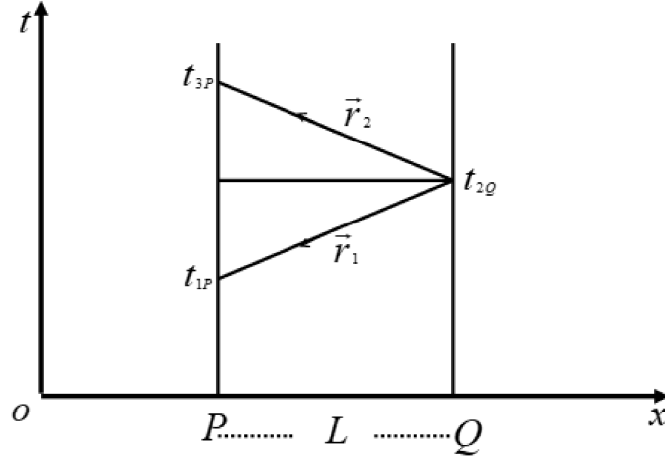

Fig. (3)

you reach it at the moment t_{2Q} with speed v_1 , and at this moment a symmetric signal from Q to P again, and it reaches it at the moment t_{3P} with speed v_2 . If the distance between the two hours L is:

$$L = v_1(t_{2Q} - t_{1P}) = v_2(t_{3P} - t_{2Q}) \quad (18)$$

This is the condition that must be met if the two clocks are accurate. Assuming that this condition is fulfilled, the question that arises now is whether P , Q each of the two is static in relation to the space in which the light (ether) is traveling. Assuming that the speed of light with respect to the ether is higher c , and the speed of the ether with respect to the affiliate frame S is u :

$$c = \frac{1}{2}(v_1 + v_2) , \quad (19)$$

$$u = \frac{1}{2}(v_1 - v_2) .$$

From this it becomes clear that P, Q , they are not static in relation to the ether, and that by knowing each v_1, v_2 , their velocity can be determined with respect to the *Ether* and we will see in the next item when we discuss the experiment of Michelson and Morley that this conflicts with the results of the experiment.

9. Scientific Contradictions in Classical Physics:

In the second half of the nineteenth century, scholars conducted experiments to verify the correctness of classical assumptions and laws. Which led to the emergence of scientific contradictions and many questions that called for the need to reconsider the basic concepts on which Newton's laws and Maxwell's theory are based. We will address some of these experiences here.

a) Fizeau & Fresnel experiment

Both *Fizeau and Fresnel* conducted experiments around 1859 to measure the velocity of light in moving materials. *Fizeau* found that the speed of light u in a fluid moving in a tube at a velocity v is:

$$u = \frac{c}{n} \pm v \left(1 - \frac{1}{n^2}\right) . \quad (20)$$

Where n is the refractive index of the liquid and the signal \pm depending on whether the liquid is moving in a direction or opposite to the velocity of light. It was expected, according to Newton's laws, that the velocity of light in this case would be:

$$u = \frac{c}{n} \pm v . \quad (21)$$

b) Michelson & Morely experiment

Scientists have assumed the existence of the ether as a material medium that carries light waves and allows the movement of physical bodies without friction and the velocity of light in which the *Ether* is present is c and it is assumed that the Earth moves around

The sun has a velocity of about **30 km / sec**. Under the assumption of the presence of the *Ether*, this velocity represents the Earth's velocity

with respect to the ether, and therefore it can be measured with respect to it.

Both Mickelson and Morley made an experiment to discover the relative motion of the Earth with respect to the ether, using the device shown in Figure (4)

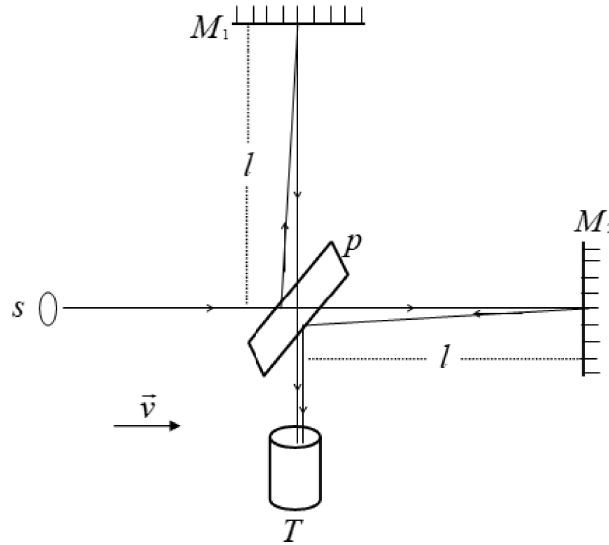

Fig. (4)

M_1 , M_2 two flat mirrors, p a half-silvered sheet of glass to let in and reflect the light, a s light source, a T telescope.

Assume that the velocity of the Earth (the device) in relation to the ether is v , and that the length of the arms pM_1 , pM_2 are equal and equal to l use: the light comes out from the light source s , where some of it enters the mirror M_2 , is reflected back to the telescope T , and some is reflected from p to the mirror M_1 and then reflected back to the telescope T , where it records the arrival time of the two rays. As the velocities of light and device with respect to the ether are c , v , respectively. If the velocity of light with respect to the device in both directions pM_2 , M_2p , is $c \pm v$ in the vertical direction pM_1 it is equal to: $\sqrt{c^2 - v^2}$ From this, the arrival time of the ray pM_2 to the telescope is equal to:

$$\frac{l}{c - v} + \frac{l}{c + v} = 2lc / (c^2 - v^2) \ .$$

And the arrival time of the ray pM_1 to the telescope:

$$2l / \sqrt{c^2 - v^2} \ .$$

It is clear that there is a time difference for the arrival of the two rays, assuming that is Δt :

$$\begin{aligned} \Delta t &= 2l / \sqrt{c^2 - v^2} - 2lc / (c^2 - v^2) \\ &= \frac{2l}{\sqrt{c^2 - v^2}} \left[1 - \frac{c}{\sqrt{c^2 - v^2}} \right] \ . \end{aligned} \quad (22)$$

And since $v \ll c$, by approximation, equation (22) becomes in the form:

$$\Delta t = \frac{l}{c} \frac{v^2}{c^2} \ . \quad (23)$$

This time difference causes interference in the light, which results in light rings that can be seen with the telescope. If n the number of rings , λ is the length of the light wave, then:

$$\Delta t = n\lambda \ . \quad (24)$$

Although the experiment was repeated at different times of the year and over many years, no light rings were observed. This means that there is no time difference between the arrival of the two rays.

10. Scientists' attempts to explain previous results:

a) Ether Drag assumption

To explain the results of the two previous experiments, the scientists assumed that the bodies "drag" the *Ether* with them, resulting in the velocity of the bodies with respect to the *Ether* is equal to zero. This

assumption contrasts with measurements made on the diffraction of light from the stars, where it was found that the measurements are consistent with the movement of the *Earth* at a velocity of about **30 km / sec.**

b) Fitzgeald-Lorntz assumption

The previous result of the Michelson and Morley experiment can be explained by assuming that moving objects contract their lengths in the direction of motion by:

$1: \sqrt{1 - v^2/C^2}$. That is, the length pM_1 does not equal l , but rather shrinks to become: $l\sqrt{1 - v^2/C^2}$. In this case, the time of arrival of the ray pM_2 to the telescope is:

$$\frac{2lc \sqrt{1 - v^2/c^2}}{c^2 - v^2} = 2l \sqrt{1 - v^2/c^2} .$$

This is exactly equal to the ray's arrival time pM_1 .

11. The scientific ideas that paved the way for the theory of special relativity:

a) Lorentz's theory

In the period between the years 1895 - 1904, Lorentz was able to formulate a theory that explains the contradictions that have appeared in physics until this time. In his theory, Lorentz believed in Newtonian notions of absolute time and space, as he assumed that the frame in which the *Ether* is static is the absolute frame (in which Maxwell's equations take the simplest form) and when he tried to find the transformations that make Maxwell's equations "invariant in form" in the same frames Inertia, Lorentz arrived at the following formulas, which are known by his name:

$$\begin{aligned} x' &= \beta (x - Vt) & y' &= y & z' &= z \\ t' &= \beta \left(t - \frac{Vx}{c^2} \right) & \beta &= 1 / \sqrt{1 - V^2/c^2} . \end{aligned} \quad (25)$$

Where V the tire velocity S' is relative to S , and the relative movement in the direction of the axis ox . By means of this transformation, it can be concluded that objects contract their lengths in the direction of motion while not occurring in other directions. Since movement means that the body has traveled some distance in a certain time, the period of time must also change the result of the movement. This explains the change of time from one frame to another, as is evident from the Lorentz Transformation (25). On this basis, the physical structure of the universe is such that moving objects contract in the direction of their movement, and this contraction cannot be measured by natural means, as the "*meterstick*" also suffers the same amount of contraction, so it is not possible, for example, to measure the velocity of the *Earth* with respect to the *Ether*.

b) Poincare Ideas

Since the relative motion of bodies in relation to the *Ether* cannot be detected, the physical scientist Poincaré wondered in 1904 AD whether this *Ether* has a real and natural existence. Likewise, in Newton's mechanics, the action or action of the force moves momentarily, that is, if we have two bodies, each of them It affects the other with a force felt by both bodies at the same moment of their effect - Newton's third law - and if we change the position of one of them, the effect changes and moves to the new position at the same time. This situation can be envisioned by imposing an infinite velocity in magnitude for the transmission of influence or action. But this proved to be incorrect, as light as one of the paths of influence takes time to travel from one place to another (the time of transmission of light from the sun to the earth is about 8 minutes). Poincaré declared that the actions spread with a limited speed and assumed that the velocity of light c in space represented the ultimate end of all possible velocities. Therefore, Newton's laws must be replaced by others in which all possible velocities are less than the velocity of light in space. That is, the velocity of light denotes the final velocity. This was the situation in the year 1904 - 1905 AD when Einstein came out with his theory, without knowing about Lorentz's theory or Poincaré ideas, as he called for the abandonment of the idea of the *Ether* and the absolute concepts of Newton.

Chapter Two

The Special Theory of Relativity

Chapter Two

The Special Theory of Relativity

1. The Postulates of Special Relativity:

Einstein had built the special theory of relativity on two main postulates:

a) The first postulate:

Physical laws do not depend on the movement of inertial frames attributed to and measured in it. In other words, all inertial frames are equivalent to describe physical phenomena. This is called Einstein's principle of relativity.

It is noted that this principle dispenses with the assumption of the existence of the ether, since if it is assumed that the aether can be discovered, then it is possible to specify the motions of all inertial frames with respect to it, which contradicts the principle of relativity and does not agree with the observations. This principle can be seen as a generalization of Galileo principle of relativity, which requires the preservation of physical laws in their inertial frames under the Galileo transformation, while Einstein's principle does not require this, but - as we shall see later - it leads to other transformations more general than Galileo transformation.

b) The second postulate:

The velocity of light does not depend on the speed of the source of radiation or the observer who measures it, this is called the principle of the constant speed of light.

2. The Lorentz Transformation:

According to Einstein's assumptions, transformation formulas between inertial frames could be found.

Consider two observers A, B in S, S' frames. Fig. (5). At $t = t' = 0$, let A, B are equals.

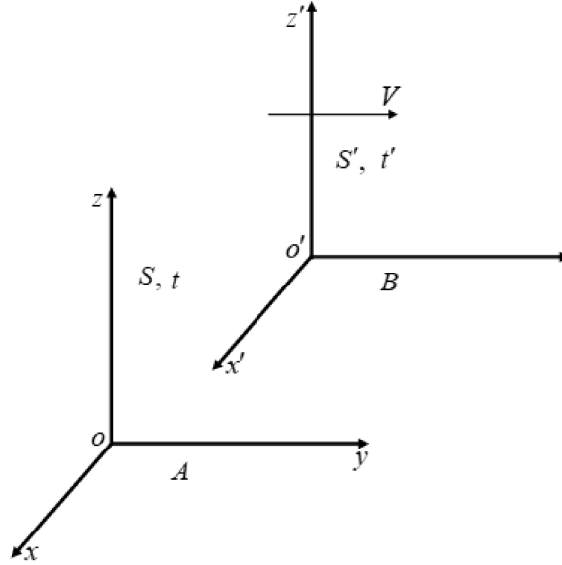

Fig. (5)

At the same moment, each of them emits a light signal. Let S' (and the observer B) moves relative to S (observer A) with a constant velocity V in ox direction. In this case the light signal propagates from both observations as a spherical wave. Consider A, B measurements.

A- Measurements:

At the moment t the equation of the wave surface appears as:

$$x^2 + y^2 + z^2 - c^2 t^2 = 0 \quad (1)$$

B - Measurements:

At the moment (t') the equation of the wave surface appears as:

$$x'^2 + y'^2 + z'^2 - c'^2 t'^2 = 0 \quad (2)$$

Using the principle of the constant speed of light from the second postulate:

$$c = c' \quad (3)$$

Then equation (2) will be

$$x'^2 + y'^2 + z'^2 - c^2 t'^2 = 0 \quad (4)$$

From this we see that the necessary transformation should be such that:

$$x'^2 + y'^2 + z'^2 - c^2 t'^2 = x^2 + y^2 + z^2 - c^2 t^2 \quad (5)$$

If the lengths do not change in the vertical directions on the movement, we can say that.

$$y' = y, \quad z' = z \quad (6)$$

In this case the relationship (5) becomes :

$$x'^2 - c^2 t'^2 = x^2 - c^2 t^2 \quad (7)$$

Assume that the transformation has the following formula:

$$x' = \beta x + \alpha t, \quad (8)$$

$$t' = \gamma x + \delta t.$$

Where $\delta, \gamma, \beta, \alpha$ constants are to be determined in the following manner: we consider the movement of the origin O' with respect to S'' :
 O' coordinate is $x' = 0$ Substituting in the first equation of equation (8), we can get O' velocity relative to S as :

$$\frac{x}{t} = -\frac{\alpha}{\beta} = V.$$

So, we get:

$$\alpha = -\beta V.$$

Considering O movement in relative to S' and O coordinate is $x=0$
 Substituting in the two equations (8) we find that:

$$\frac{x'}{t'} = \frac{\alpha}{\delta} = -V.$$

From that we get:

$$\delta = \frac{\alpha}{V} = \beta \quad . \quad (10)$$

In this case the two equations (8) become:

$$\begin{aligned} x' &= \beta (x - Vt) \ , \\ t' &= \gamma x + \beta t \quad . \quad (11) \end{aligned}$$

Substituting in (7) we find that.

$$\beta^2 (x - Vt)^2 - c^2 (\gamma x + \beta t)^2 = x^2 - c^2 t^2 \quad . \quad (12)$$

Comparing the factors of the two sides results in:

$$\beta = 1 / \sqrt{1 - V^2 / c^2} \quad , \quad \gamma = -\beta V / c^2 \quad . \quad (13)$$

Thus, it will be concluded that the required transformation takes the following form:

$$\begin{aligned} x' &= \beta (x - Vt) \quad y' = y \quad z' = z \\ t' &= \beta (t - \frac{Vx}{c^2}) \quad \beta = 1 / \sqrt{1 - V^2 / c^2} \quad . \end{aligned} \quad (14)$$

This transformation is called the Lorentz transformation, and it is noted that the transformation formulas fit perfectly with the transformations that Lorentz imposed on his theory.

Except Its physical meaning is completely different from what Lorentz conceived .While Lorentz built his theory on absolute concepts and explains the change of lengths from frame to another as a real contraction, we find that Einstein refuses absolute concepts, which is produced from his postulates that length and time change from one frame to another according to the Lorentz transformation (14)

The Lorentz transformation (14) corresponds to Galileo Transformation (11) in the first chapter when it tends to infinity, this is the meaning of saying that the velocity of light denotes infinite velocity in Newton laws, from another point of view, a Lorentz transformation is corresponding to the transformation of Galileo roughly when:

$$V \ll c \quad (15)$$

This is the condition for applying Newton's laws of motion to physical phenomena. but if the velocity of the objects is close to the velocity of light, then Newton mechanics, fails to explain the natural phenomena that arises in this case and it must be replaced by mechanics of another kind that is consistent with Einstein's postulates (Lorentz transform) he calls it relativistic mechanics.

3. Setting the spaced clocks:

By repeating the same experiment in section 8 from the first chapter – fig. (3) – and considering the second postulate of Einstein, So:

$$v_1 = v_2 = c \quad (15)$$

So, the condition of setting the P , Q clocks in the static frames S

$$t_{2Q} = \frac{1}{2}(t_{1P} + t_{3P}) \quad (16)$$

4. Properties of Lorentz transformation:

The basis of relativistic mechanics is in the Lorentz transformation and to show the changes in classic concepts its preferred to Lorentz transformation mode in the differential form:

$$\begin{aligned} dx' &= \beta (dx - Vdt) , dy' = dy , dz' = dz , \\ dt' &= \beta (dt - \frac{V}{c^2} dx) \quad (17) \end{aligned}$$

From this form, the following properties of the Lorentz transformation could be deduced.

a) **Inverse Lorentz transformation** is also the Lorentz transformation :

By solving equations (17). to find dx, dt by knowing dx', dt'

$$\begin{aligned} dx &= \beta (dx' + V dt') \quad , \\ dt &= \beta (dt' + \frac{V}{c^2} dx') \quad . \end{aligned} \quad (18)$$

This is the same as the Lorentz transformation by substituting the velocity ($-V$) instead of V .

b) **Under Lorentz transformation the expression:**

$$(dx)^2 + (dy)^2 + (dz)^2 - c^2 (dt)^2$$

Is "invariant" in form:

If we gave the symbol $(ds)^2$ to this expression and by using The Lorentz transformation inverse then we get :

$$\begin{aligned} (ds)^2 &= \beta^2 (dx' + V dt')^2 + (dy')^2 + (dz')^2 - \beta^2 c^2 (dt' + \frac{V}{c^2} dx')^2 \\ &= \beta^2 (1 - \frac{V^2}{c^2}) (dx')^2 + (dy')^2 + (dz')^2 - \beta^2 c^2 (1 - \frac{V^2}{c^2}) (dt')^2 \quad (19) \\ &= (dx')^2 + (dy')^2 + (dz')^2 - c^2 (dt')^2 \quad . \end{aligned}$$

This expression $(ds)^2$ which maintains its form under Lorentz transformation, Geometrically, it is the square of the total distance between two nearby events specified by the coordinates $(x, y, z, t), (x + dx, y + dy, z + dz, t + dt)$ in the 4-space-time Also (ds) is called the (Space-time interval). this result is completely different from that in Galileo transformation that separates the immutable $(d\vec{r})^2$ and the temporal variable $(dt)^2$

$$\begin{aligned} (d \vec{r})^2 &= (d \vec{r}')^2 \quad , \\ (dt)^2 &= (dt')^2 \quad . \end{aligned} \quad (20)$$

This separation in time and space is the result of assuming that time is absolute but in Lorentz transformation, time changes from one frame to

another, completely like changing spatial coordinates. Which makes time and space connected quadrantally (space-time). In this 4 – space - time, events are represented by coordinates (x, y, z, t) and the connecting line between them gives the evolution event from his past to his future and this line is called the "World line".

5. Properties of Lorentz transformation:

a) Fitzgerald - Lorentz contraction:

Consider two rods exactly the same when they are still with respect to each other, fix the rods parallel to the axis ox one of them in the S frame and the other in S' frame so that the two grades are easy to compare when sliding one on the other Fig. (6)

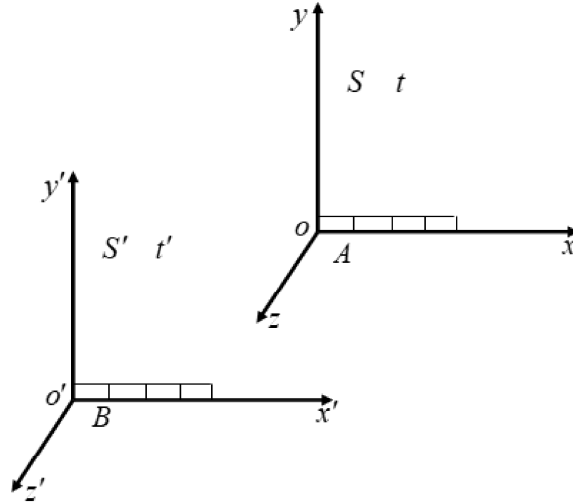

Fig. (6)

Let observer B puts two signs on the rod which determine the distance dx' , and the observer A observes two events of occlusion of both ends of the distance dx' on the scale of his rod when S' moves across it. In this case the two events must be recorded at the same moment $dt = 0$, from the Lorentz transformation (17) we find that

$$dx' = \beta dx = dx / \sqrt{1 - V^2 / c^2} \quad (21)$$

Where V is the velocity of S' relative to S

$$dx = dx' \sqrt{1 - V^2 / c^2} \quad (22)$$

From which it results that :

$$dx < dx' \quad .$$

If the length of the rod in S' is L_0 and in S is L :

$$L = L_0 \sqrt{1 - V^2 / c^2} \quad . \quad (23)$$

This means that a rod of length L_0 is measured by B (static with respect to S') it appears shrunk if measured by A (moving relative to it). It must be understood here that this contraction can not be measured by natural methods or, it corresponds to real contraction of objects as a result of their movements with respect to an absolute frame in which length and time are absolute concepts.

In the theory of relativity, we have replaced the absolute concepts of Newton with the last relativity changes according to the moving frames that we measure these concepts relative to.

b) Simultaneity of events:

According to Galileo transformation:

$$dt = dt' = 0 \quad .$$

That means, if two events happen at the same moment within a framework, they both happen at the same moment in all other frames .But we'll find that the ultimate concept of instantaneous events takes on another meaning, according to the Lorentz transformation.

Consider two simultaneous events with respect to S' at $dt' = 0$.
Using the Lorentz transformation (17) we find that :

$$dt = \frac{V}{c^2} dx \quad . \quad (24)$$

This means that the events in the two immediate situations S' is not the same as in S .

c) Time dilatation:

Consider two events that happen consecutively took place relative to the observer B in S' , if we assumed that the time period between them is dt' so, using equation (18) after putting $dx' = 0$ that:

$$dt = \beta dt' \quad (25)$$

Then we get

$$dt > dt'$$

If T_0 is the time period measured in S' and T at S then

$$T = T_0 / \sqrt{1 - V^2 / c^2} . \quad (26)$$

From this it is evident that a clock is given a power time lapse T_0 that measured by B (Static relative to B) will give a time of T if measured by A (moving relative to itself).

d) Velocity transformations:

Assume that a particle is moving with velocity \vec{u} with respect to S and \vec{u}' with respect to S' .

$$\begin{aligned} \vec{u}' &= (u'_1, u'_2, u'_3) , \quad \vec{u} = (u_1, u_2, u_3) , \\ u_1 &= \frac{dx}{dt} , \quad u_2 = \frac{dy}{dt} , \quad u_3 = \frac{dz}{dt} , \end{aligned} \quad (27)$$

Using the Lorentz transformation in the formulas (27) we get :

$$u_1 = \frac{dx' + V dt'}{dt' + \frac{V}{c^2} dx'} = \frac{u'_1 + V}{1 + \frac{V u'_1}{c^2}} , \quad (28)$$

$$u_2 = \frac{1}{\beta} \frac{u'_2}{1 + \frac{V u'_1}{c^2}} , \quad (29)$$

$$u_3 = \frac{1}{\beta} \frac{u'_3}{1 + \frac{V u'_1}{c^2}} . \quad (30)$$

Results

- (i) **It is** observed that \mathbf{u}_1 is the resultant of the two velocities $\mathbf{V}, \mathbf{u}'_1$ in the same direction .According to classical mechanics:

$$\mathbf{u}_1 = \mathbf{u}'_1 + \mathbf{V} \quad .$$

This can be obtained from the formula (28) if we assumed that \mathbf{c} corresponds to the infinity or $\mathbf{V} \ll \mathbf{c}$.So, if \mathbf{u} is the resultant of the two-velocities \mathbf{v} and \mathbf{w} in the same direction. It will be formulated in the theory of Special relativity such that:

$$u = \frac{v + w}{1 + \frac{vw}{c^2}} \quad (31)$$

This formula is called Einstein's law of summation of velocities.

- (ii) It is noted that the velocity components that move in the perpendicular direction ($\mathbf{u}_2, \mathbf{u}_3$) are changing also, other than coordinates, however If $\mathbf{u}'_2, \mathbf{u}'_3$ **vanish** then $\mathbf{u}_2, \mathbf{u}_3$ **will** vanish

- (iii) Formula (31) can be written as :

$$\begin{aligned} 1 - \frac{u}{c} &= 1 - \frac{1}{c} \frac{v + w}{1 + \frac{vw}{c^2}} \\ &= \left(1 - \frac{v}{c}\right) \left(1 - \frac{w}{c}\right) / \left(1 + \frac{vw}{c^2}\right) \quad . \end{aligned} \quad (32)$$

From this we conclude that if $\mathbf{v} = \mathbf{c}$ or $\mathbf{w} = \mathbf{c}$ then $\mathbf{u} = \mathbf{c}$ also that means, the resultant of two velocities, one of them is the velocity of light in space, is equal to the velocity of light in space .This means that velocity of light in space is the fastest possible velocity.

- (iv) To find the transformation of the square velocity , $(\vec{u})^2$ put (30) - (28) in the form :

$$u'_1 = \frac{u_1 - V}{1 - \frac{V u_1}{c^2}} \quad . \quad (28)'$$

$$u'_2 = \frac{1}{\beta} \frac{u_2}{1 - \frac{V u_1}{c^2}} \quad (29)'$$

$$u'_3 = \frac{1}{\beta} \frac{u_3}{1 - \frac{V u_1}{c^2}} \quad (30)'$$

By squaring and adding together and noting that $u_1 V = \vec{u} \cdot \vec{V}$ we get :

$$\begin{aligned} (\vec{u}')^2 &= \frac{1}{\left(1 - \frac{\vec{u} \cdot \vec{V}}{c^2}\right)^2} \left[u_1^2 - 2\vec{u} \cdot \vec{V} + V^2 + \frac{1}{\beta^2}(u_2^2 + u_3^2) \right] \quad (33) \\ &= \frac{1}{\left(1 - \frac{\vec{u} \cdot \vec{V}}{c^2}\right)^2} \left[(\vec{u})^2 - 2\vec{u} \cdot \vec{V} + V^2 - \frac{1}{c^2}(\vec{u} \wedge \vec{V})^2 \right] \end{aligned}$$

6. Important property of the Lorentz transformation:

We know that the Galileo transformation can be formed as follows:

$$\begin{aligned} \vec{r}' &= \vec{r} - \vec{V}t, \quad (34) \\ t' &= t. \end{aligned}$$

If we have three frames of inertia $\mathcal{S}, \mathcal{S}', \mathcal{S}''$ where \vec{V} is the velocity of \mathcal{S}' relative to \mathcal{S} in Ox direction and \mathcal{S}'' moves with \vec{V}' relative to \mathcal{S}' on Ox' direction. The Galileo transformation connecting between \mathcal{S}' and \mathcal{S}'' is :

$$t'' = t' \quad \vec{r}'' = \vec{r}' - \vec{V}'t', \quad (35)$$

and this results from the transformation, which connects \mathcal{S} and \mathcal{S}''

$$\begin{aligned} \vec{r}'' &= \vec{r} - \vec{V}t - \vec{V}'t' \\ &= \vec{r} - (\vec{V} + \vec{V}')t, \quad (36) \\ t'' &= t. \end{aligned}$$

Also converting Galileo in velocity ($\vec{V} + \vec{V}'$) to all directions of velocity expressing about it that Galileo transfers between frames with inertia be with each group is characterized by this group two special characteristics:

- (i) It contains the unit element that transforms the frame itself, and this element is denoted by the symbol:

$$e : S \longrightarrow S$$

- (ii) The resultant of the two components (two transformations) also be an element in the group .That is, if G_1, G_2 are two elements of the group where :

$$G_1 : S \longrightarrow S' \quad , \quad G_2 : S' \longrightarrow S''$$

Then the resultant of them is

$$G_2 G_1 : S \longrightarrow S''$$

It is clear from this that the elements (transformations) differ with the change of velocity frames. It is expressed that the group has a parameter \vec{v}

$$G_1 = G(\vec{v}) \quad , \quad G_2 = G(\vec{v}')$$

The product of $G_2 G_1$ is an element with the parameter $\vec{v} + \vec{v}'$.Where:

$$G_2 G_1 = G(\vec{v}') G(\vec{v}) = G(\vec{v} + \vec{v}')$$

This property is also applied to Lorentz transformations in case of parallel velocities \vec{v} , \vec{v}' only .To prove this, suppose the frames S, S', S'' move relative to each other in the direction of ox with the velocities V, V' respectively .

If we denote to the two transformations among the three frames, respectively, by the two symbols $L(V), L(V')$ then:

$$L(V) :$$

$$\begin{aligned} x' &= \beta (x - Vt) \quad , & (37) \\ t' &= \beta \left(t - \frac{Vx}{c^2} \right) \quad , \quad \beta = 1 / \sqrt{1 - V^2 / c^2} \quad . \end{aligned}$$

$L(V')$:

$$x'' = \beta' (x' - V't') \quad , \quad (38)$$

$$t'' = \beta' \left(t' - \frac{V'x'}{c^2} \right) \quad , \quad \beta' = 1 / \sqrt{1 - V'^2 / c^2} \quad .$$

By substituting x', t' from equation (37) in equation (38)
We get the product of the two elements $L(V), L(V')$

$L(V') L(V)$:

$$\begin{aligned} x'' &= \frac{1}{\sqrt{1 - u^2 / c^2}} (x - ut) \quad , \\ t'' &= \frac{1}{\sqrt{1 - u^2 / c^2}} \left(t - \frac{u}{c} x \right) \quad . \end{aligned} \quad (39)$$

Where u is the sum of the two velocities V, V' according to Einstein's law (31) From this results that:

$$L(V') L(V) = L(u) \quad .$$

The resulting transformation is a Lorentz transformation with velocity u is called as the resultant of the last two transformations.

We will now study the case when the two velocities V, V' are not in one direction, but orthogonal. Take V in the direction ox , the velocity V' is in the direction oy . In this case, they become transfers Lorentz on the formula:

$$\begin{aligned} x'' &= x' = \beta (x - Vt) \quad , \\ t'' &= t' = \beta \left(t - \frac{Vx}{c^2} \right) \quad , \\ y'' &= \beta' (y - V't') \\ &= \beta' \left(y + \beta \frac{VV'}{c^2} x - \beta V't \right) \quad . \end{aligned} \quad (40)$$

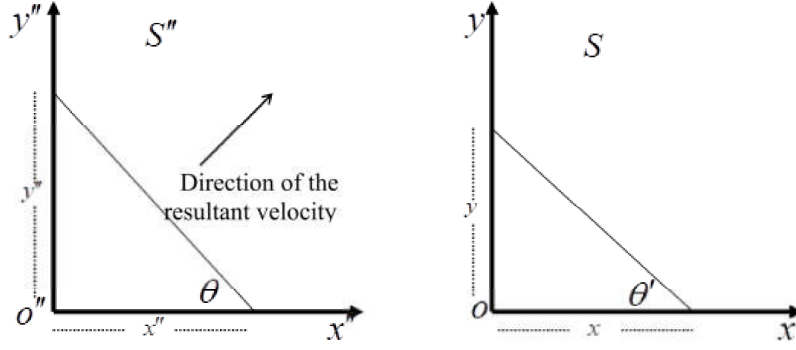

Fig. (7)

If θ was the angle that the straight line laying between the two axes $o''y''$, $o''x''$ in S'' with $o''x''$, then the length of this part – fig. (7) – equals:

$$x'' \cos \theta + y'' \sin \theta = \beta x \left(\cos \theta + \beta' \frac{VV'}{c^2} \sin \theta \right) + \beta' y \sin \theta - \beta t \left(V \cos \theta + \beta' V' \sin \theta \right) \quad (41)$$

As the length of the perpendicular part on the movement is static, then the θ value of that corresponds the perpendicular direction of movement is found by equaling the coefficient of t with zero:

$$\tan \theta = -V / V' \beta' \quad (42)$$

By substituting in equation (41), we find that:

$$x'' \cos \theta + y'' \sin \theta = -V'x / \beta U + Vy / U \quad (43)$$

$$= x \cos \theta' + y \sin \theta' \quad .$$

Where:

$$U^2 = V^2 + V'^2 - V^2 V'^2 / c^2 \quad , \quad (44)$$

$$\tan \theta' = -V \beta / V'^2 \quad . \quad (45)$$

It's clear that $\theta \neq \theta'$. We conclude that there is a rotation by $\theta - \theta'$ beside the resultant Lorentz transformation, to find the value of rotation we know that:

$$\begin{aligned} \tan(\theta - \theta') &= \frac{\tan \theta - \tan \theta'}{1 + \tan \theta \tan \theta'} \\ &= \frac{V(\beta - 1/\beta')}{V'(1 + V^2\beta/V'^2\beta')} \\ &= \frac{VV'(\beta\beta' - 1)}{\beta V'^2 + \beta' V^2} . \end{aligned} \quad (46)$$

If $V, V' \ll c$, we can make the following rounding:

$$\beta \cong 1 + \frac{1}{2} \frac{V^2}{c^2}, \quad \beta' \cong 1 + \frac{1}{2} \frac{V'^2}{c^2} .$$

By substituting in (46) and considering the angle $\theta - \theta'$. Is small, then:

$$\tan(\theta - \theta') \cong \theta - \theta' = \Delta\theta = \frac{1}{2} \frac{VV'}{c^2} . \quad (47)$$

This rotation is called Thomas precession and has a big role in the new biology science (Electron rotation)

7. Clock Paradox:

In the early days of relativity there were many discussions about It is called the "clock paradox" although there is no contradiction in the correct mean. Consider observers, each supplied with a watch. At first, we assume that they are together, and their clocks are correct. Let **A** moves with speed V with respect to **B**, and after a certain distance it goes back to **B** where he compares with **B** watch according to the phenomenon of **Time dilatation**, the **A** hour will appear slower than the **B** hour. But we can Suppose that **A** it is still, and that **B** it moves in the opposite direction with $-V$ speed. From that we deduced that the two hours must be affected by the same time resolves this paradox is shown in the assumption that the observers **A**, **B** are equivalent, but there is no natural equivalence, as one of them **B** was still, while the other **B** moved and

then changed the direction of its movement which necessitates the impact of force on him.

Problems

- 1- Prove that Lorentz transformations is a reciprocal group if speeds were in the same direction.
- 2- Prove that the element of length and the element of time in the triple space are not under Lorentz transformation.
- 3- Find the transformation of the element of volume for an object with respect to the two inertia of frames S, S' , and prove that the volume is shrinking in the direction of movement.
- 4- If a rocket traveled around the earth with a speed of $\frac{1}{10} c$, where c is the speed of light. **Find** rocket's percentage of shrinkage with respect to an observer on the earth.
- 5- If the speed of light in a liquid was $\frac{c}{n}$, where n is the coefficient of light refraction, show that the speed of light u in the liquid when it moves with $V \ll c$ is given by: $u = \frac{c}{n} \pm V(1 - \frac{1}{n^2})$ according to the direction of liquid movement with respect to light.

Chapter Three

Geometric Representation of The Theory of Special Relativity

Chapter Three

Geometric Representation of The Theory of Special Relativity

1. The 4 – dimensional space-time of Minkowski:

We know that under the Lorentz transform (14) the square of the space-time component :

$$(ds)^2 = (dx)^2 + (dy)^2 + (dz)^2 - c^2(dt)^2 \quad (1)$$

remains "Invariant" in form

In 1908 AD, Minkowski introduced the following variables:

$$x_1 = x, \quad x_2 = y, \quad x_3 = z, \quad x_4 = ict \quad . \quad (2)$$

Where $i = \sqrt{-1}$. In this case $(ds)^2$ takes the form:

$$(ds)^2 = (dx_1)^2 + (dx_2)^2 + (dx_3)^2 + (dx_4)^2 \quad . \quad (3)$$

From the geometric point of view ds is called in the equation (3), the left of the Euclidean quadrilaterals (ie the plane) is called where the differential coefficients dx_1, dx_2, \dots are equal to the unit. In the general case, the geometric properties of space can be deduced from these coefficients in "Euclidean" geometry. The differential coefficients are functions of the variables. Likewise, if the differential coefficients are in order $(1, 1, 1, -1)$ then the space is called a *Pseudo-Euclidean* space, sometimes called the Euclidean space in which the coordinate is The fourth x_4 is to imagine the quadrant of Minkowski space. In terms of coordinates (x_1, x_2, x_3, x_4) , the Lorentz transform can be placed on the formula:

$$\begin{aligned} x'_1 &= \beta \left(x_1 + i \frac{V}{c} x_4 \right), \quad x'_2 = x_2, \quad x'_3 = x_3, \\ x'_4 &= \beta \left(x_4 - i \frac{V}{c} x_1 \right) \quad . \quad (4) \end{aligned}$$

Using compensation:

$$\tan \theta = i \frac{V}{c} . \quad (5)$$

We find that equations (4) become as:

$$\begin{aligned} x'_1 &= x_1 \cos \theta + x_4 \sin \theta , \\ x'_4 &= x_4 \cos \theta - x_1 \sin \theta . \end{aligned} \quad (6)$$

(We will dispense with the other coordinates later x_2, x_3)

This means that the Lorentz transform can be represented geometrically by the rotation of the axes ox_1, ox_4 , in the quadrilaterals of Minkowski with an imaginary angle θ given by the formula (5).

In other words, to turn from the frame S to S' rotate the axes ox_1, ox_4 , by the angle θ . With this geometric method, the event is represented by a point in the quadrilateral space (x_1, x_2, x_3, x_4) , in order to describe the event with respect to the moving frame, we have to read the new coordinates

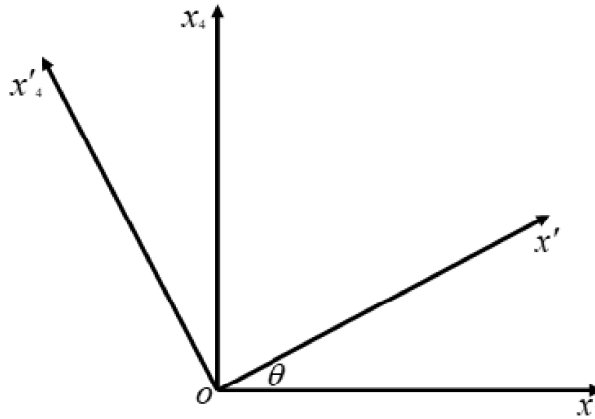

Fig. (8)

(x'_1, x'_2, x'_3, x'_4) we get it by rotating the two axes ox_1, ox_4 , by an angle:

$$\hat{x}_1 o x_4 = \theta = \tan^{-1}(iV/c) .$$

Also, an inverse Lorentz transform takes the picture:

$$\begin{aligned} x_1 &= x'_1 \cos \theta - x'_4 \sin \theta , \\ x'_4 &= x_4 \cos \theta - x_1 \sin \theta . \end{aligned} \quad (6)'$$

2. World line of a particle:

A particle's natural state (its history) is described by the set of events occurring in its past, present, and future. These events are represented by points in the Minkowski 4 – dimensional space - time.

a) World line of a static particle:

Since the static particle occupies the same subject (place) at different times, the world line for it is a straight line **LM** that

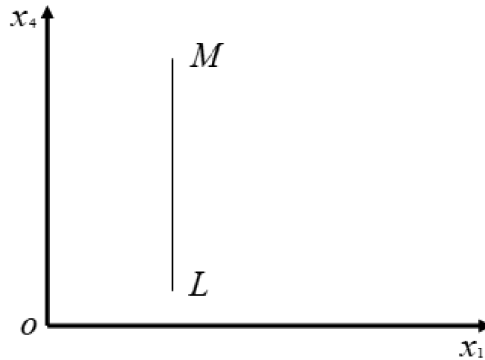

Fig. (9)

Parallel to the axis ox_4 in the plane – Fig. (9).

b) World line of a moving particle:

If we impose a particle moving with uniform velocity V parallel to the axis ox in the associative frame S , then the equation of its trajectory with respect to the observer A is:

$$x = x_o + Vt . \quad (7)$$

Using Minkowski coordinates, we get equation (7) in the form

$$x_1 = x_0 - x_4 \tan \theta \quad (8)$$

Where

$$\tan \theta = iV/c \quad (9)$$

Equation (8) represents a straight line LM that is inclined at an angle $\left(\frac{\pi}{2} + \theta\right)$ to the axis ox_1 in the plane x_1ox_4 - Fig. (3)- By rotating the two axes ox_1, ox_4 , at an angle $\theta = \tan^{-1}(iV/c)$, it becomes clear that the line LM is parallel to the axis ox_4 . That is, the particle is static with respect to the new axes - Fig. (10).

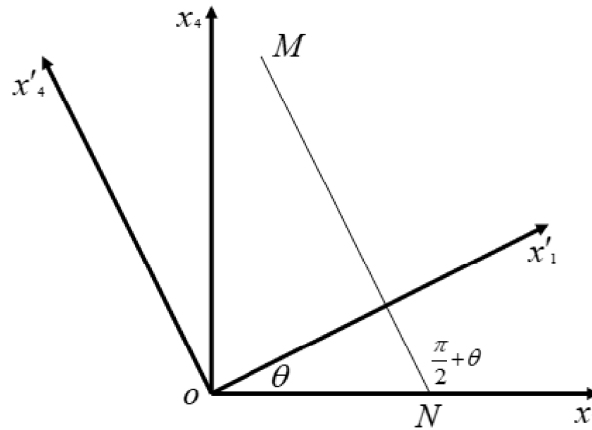

Fig. (10)

3. Geometric representation of kinematic phenomena:

a. Fitzgerald and Lorentz contraction

Since the moving rod, whose length L_0 is static with respect to the frame moving with it, i.e. with respect to the axes ox'_1, ox'_4 , the paths of different points are parallel to the axis - Fig. (11) Likewise, the bar whose length L is static with respect to the frame S i.e. with respect to the axes ox_1, ox_4 , so the paths of a point are parallel to the axis ox_4 of Fig. (11) we conclude that:

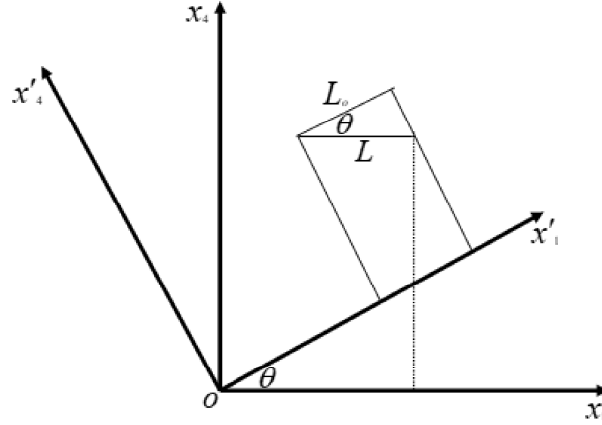

Fig. (11)

$$L_0 = L \cos \theta \quad . \quad (10)$$

From the equation (9) we find that:

$$\cos \theta = 1 / \sqrt{1 - V^2 / c^2} = \beta \quad . \quad (11)$$

From this it follows that:

$$L = L_0 \sqrt{1 - V^2 / c^2} \quad .$$

It is the same as the previous relationship (Equation (23 in Chapter Two)).

b. Simultaneity of events

Consider two simultaneous events P, Q , with respect to the frame S' these two events are represented by two points so that the connecting line between them is parallel

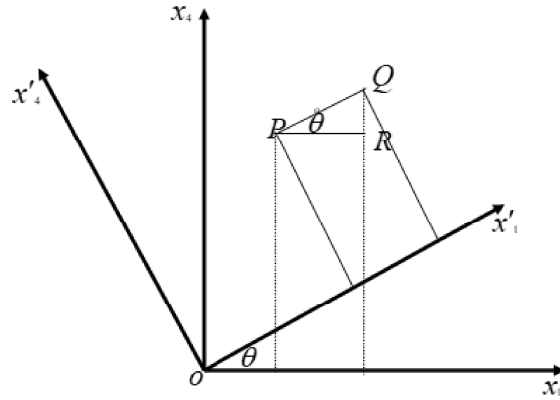

Fig. (12)

to the axis ox'_1 - Fig. (12) - it is clear from the figure that there is a time difference between the two events with respect to the frame S equal to \overline{QR} .

c. Time dilation :

Consider two events occurring at the same place with respect to S' . These two events are represented by the two points P, Q , where the connecting line between them is parallel to the axis ox'_4 – Fig. (13) - the time difference between the two events measured with respect to S' is:

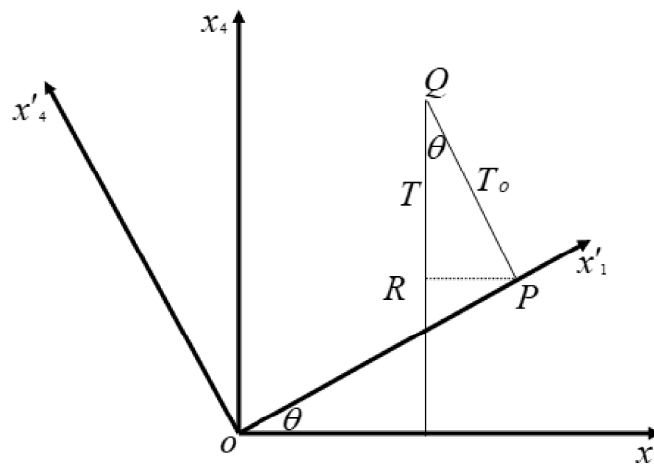

Fig. (13)

$$T_o = \overline{PQ} \quad . \quad (13)$$

For \mathcal{S} the time difference is:

$$T = \overline{RQ} \quad . \quad (14)$$

It is clear from the figure that:

$$T = T_o \cos \theta = T_o / \sqrt{1 - V^2 / c^2} \quad . \quad (15)$$

It is the same as the previous relationship.

4. Proper Time:

We found that the Quadro space ds apron remains "Invariant" under Lorentz transformation, meaning that:

$$\begin{aligned} (dx_1)^2 + (dx_2)^2 + (dx_3)^2 - c^2(dt)^2 &= \quad (16) \\ (dx'_1)^2 + (dx'_2)^2 + (dx'_3)^2 - c^2(dt')^2 & \quad . \end{aligned}$$

$$\text{Or} \quad (ds)^2 = (ds')^2 \quad . \quad (17)$$

Assuming that a particle is moving with a velocity \vec{v} with respect to \mathcal{S} , then it can be considered static with respect to another frame \mathcal{S}' moving with respect to \mathcal{S} the same velocity \vec{v} and thus be:

$$\left(\frac{dx'_1}{dt'}\right)^2 + \left(\frac{dx'_2}{dt'}\right)^2 + \left(\frac{dx'_3}{dt'}\right)^2 = 0 \quad . \quad (18)$$

$$v^2 = \left(\frac{dx_1}{dt}\right)^2 + \left(\frac{dx_2}{dt}\right)^2 + \left(\frac{dx_3}{dt}\right)^2 \quad . \quad (19)$$

By substituting in (16) it comes to:

$$(ds)^2 = (v^2 - c^2)(dt)^2 = -c^2(dt')^2 \quad . \quad (20)$$

$$\text{Or} \quad dt' = \sqrt{1 - v^2 / c^2} dt \quad (21)$$

$$= -\frac{i}{c} ds \quad . \quad (22)$$

From the last equation (22) it becomes clear that the period of time dt' remains "invariant" under Lorentz transformation. That is, it does not change from one frame to another from one of the inertial frames. The time t' in this case is called the local time and is symbolized by the symbol τ where

$$d\tau = \sqrt{1 - v^2/c^2} dt \quad . \quad (23)$$

5. Light Cone:

If two neighboring events occur, in the 4 – dimensional space-time then square distance between them is given by the formula:

$$\begin{aligned} (ds)^2 &= (dx_1)^2 + (dx_2)^2 + (dx_3)^2 - c^2(dt)^2 \\ &= (v^2 - c^2) (dt)^2 \\ &\leq 0 \\ &> \end{aligned} \quad (24)$$

We will now study three cases:

- i. If they are then to be less than, this is consistent with natural phenomena. In this case, the distance is called "Time Like" Because by switching to another frame in which the particle is stationary, we find that:

$$(ds)^2 = -c^2 (dt')^2 \quad . \quad (25)$$

That is, the space-time is measured in time difference only.

- ii. If $(ds)^2 = 0$ it was, then: $v^2 = c^2$. the particle moves at the velocity of light in space, and we will return to study this case later.

- iii. If $(ds)^2 > 0$ it is, then v^2 is greater than c^2 and this is not consistent with physical phenomena, so there are no physical particles moving faster than light in space. ds in this case the distance is called a "space like" because in this case it is possible to convert to another frame in which it is:

$$(ds)^2 = (dx'_1)^2 + (dx'_2)^2 + (dx'_3)^2 . \quad (26)$$

In the 4 – space time of Minkowski the equation is represented:

$$(ds)^2 = 0 . \quad (27)$$

A cone (two straight lines in the figure (14), inside the cone corresponds to the "Time Like" distances while outside it corresponds to the "space like" distances.

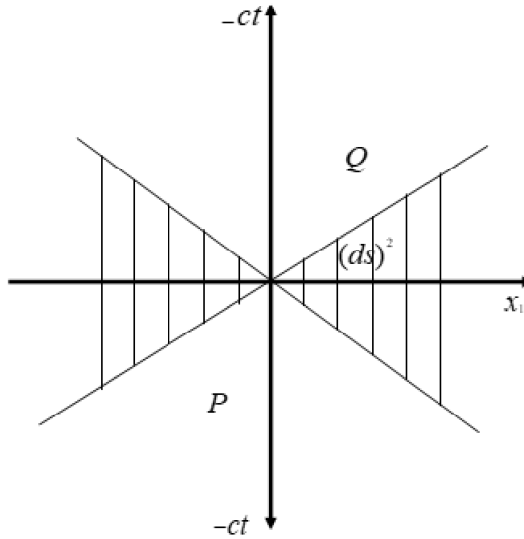

Fig. (14)

Physical events correspond to points within a cone: the lower portion **P** represents the past, the upper **Q** the future. Any line **P** that reaches **Q** through **o** is a world line. From the "Invariant" characteristic of ds under the Lorentz transform, it can be concluded that the "space like" distance always remains space like and so the "space like" always remains space like. This means that it is not possible to relate the inside of the cone

(physical events) to the outside (the abnormal events). This is known as the Causality Principle.