



**Lectures**  
**IN**  
**Atomic Physics**  
**(Modern Physics)**  
**For**  
**Third Year Students**  
**Faculty of Education**

**Prepared By**

**Dr. Badry N. Abdalla**

**2023 - 2024م**

<b>No</b>	<b>Chapter One</b>
	<b>Particle Nature of Radiation</b>
<b>4-6</b>	Introduction
<b>7</b>	Quantum theory of radiation
7-13	Black body radiation
14	Classical and Quantum postulations for black body Radiation
14-15	Classical Rayleigh-Jeans's postulate
15	Classical Wien's postulate
15-17	Quantum Max Planck's postulate
17-21	<b>Consistency of quantum Max Planck's postulate with classical postulations</b>
22-33	Photoelectric Effect Phenomenon
34-40	Compton Effect Phenomenon
<b>41-70</b>	X-ray production phenomenon
71	<b>Chapter Two</b>
	<b>Wave Nature Of Particle</b>
71-76	Matter waves (De Broglie's Hypothesis).
76-81	Experimental Varifacation of De Broglie's Hypothesis
۹۹-۸۲	<b>Heisenberg Uncertainty Principle</b>
101	<b>Chapter Two</b>
	<b>Special Relativity</b>
101-102	<b>The Galilean Transformation</b>
103-107	<b>The Michelson-Morley Experiment</b>
107	<b>Lorantz Transformation</b>
107-110	Time Dilation, Length contaction
116-118	pler Effect RelativisticDop
118-125	Relativisistic, Energy, Momentum

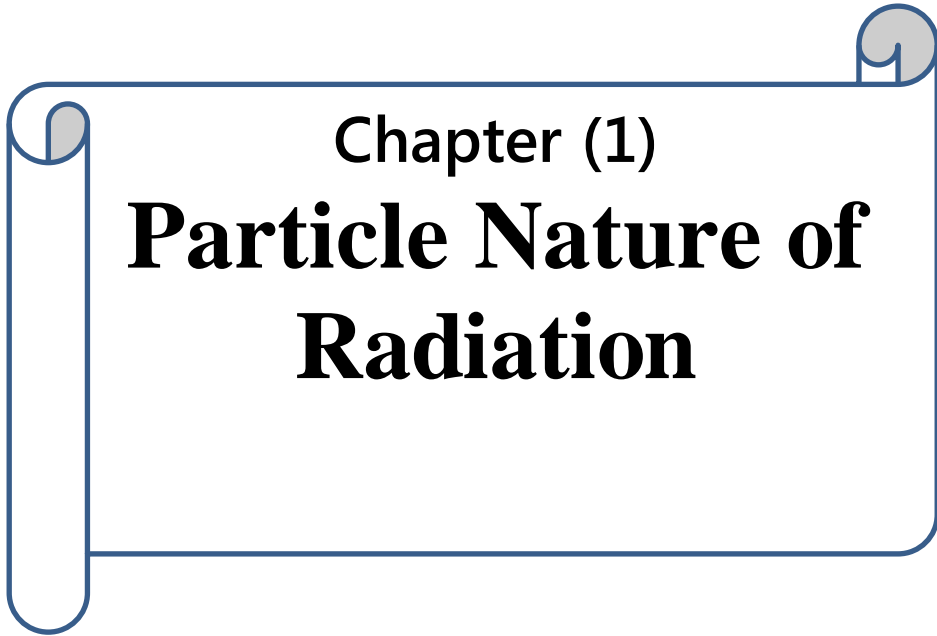

**Chapter (1)**  
**Particle Nature of  
Radiation**

**•The Failure of Classical Physics**

The failure of classical physics to explain several microscopic phenomena—such as blackbody radiation, the photoelectric effect, atomic stability, and atomic spectroscopy—had cleared the way for seeking new ideas outside its purview.

The first real breakthrough came in 1900 when Max Planck introduced the concept of the *quantum* of energy. In his efforts to explain the phenomenon of blackbody radiation, he succeeded in reproducing the experimental results only after postulating that the energy exchange between *radiation* and its surroundings takes place in *discrete, or quantized*, amounts. He argued that the energy exchange between an *electromagnetic wave* of frequency  $\nu$  and matter occurs *only in integer multiples* of  $h\nu$ , which he called the energy of a *quantum*, where  $h$  is a fundamental constant called *Planck’s constant*. The quantization of electromagnetic radiation turned out to be an idea with far-reaching consequences.

Planck’s idea, which gave an accurate explanation of blackbody radiation, prompted new thinking and triggered an avalanche of new discoveries that yielded solutions to the most outstanding problems of the time.

In 1905 Einstein provided a powerful consolidation to Planck’s quantum concept. In trying to understand the photoelectric effect, Einstein recognized that Planck’s idea of the quantization of the *electromagnetic waves* must be valid for *light* as well. So, following Planck’s approach, he posited that *light itself is made of discrete bits of energy (or tiny particles)*, called *photons*, each of energy  $h\nu$ ,  $\nu$  being the frequency of the light. The introduction of the photon concept enabled Einstein to give an elegantly accurate

explanation to the photoelectric problem, which had been waiting for a solution ever since its first experimental observation by Hertz in 1887. Another seminal breakthrough was due to Niels Bohr. Right after Rutherford's experimental discovery of the atomic nucleus in 1911, and combining Rutherford's atomic model, Planck's quantum concept, and Einstein's photons, Bohr introduced in 1913 his model of the hydrogen atom. In this work, he argued that atoms can be found only in *discrete states* of energy and that the interaction of atoms with radiation, i.e., the emission or absorption of radiation by atoms, takes place only in *discrete amounts* of  $h\nu$  because it results from transitions of the atom between its various discrete energy states. This work provided a satisfactory explanation to several outstanding problems such as atomic stability and atomic spectroscopy.

Then in 1923 Compton made an important discovery that gave the most conclusive confirmation for the corpuscular aspect of light. By scattering X-rays with electrons, he confirmed that the X-ray photons behave like particles with momenta  $h\nu / c$  ;  $\nu$  is the frequency of the X-rays.

This series of breakthroughs—due to Planck, Einstein, Bohr, and Compton—gave both the theoretical foundations as well as the conclusive experimental confirmation for the particle aspect of waves; that is, the concept that waves exhibit particle behavior at the microscopic scale. At this scale, classical physics fails not only quantitatively but even qualitatively and conceptually. As if things were not bad enough for classical physics, de Broglie introduced in 1923 another powerful new concept that classical physics could not reconcile: he postulated that not only does radiation exhibit particle-like behavior but, conversely, *material particles* themselves display

*wave-like* behavior. This concept was confirmed experimentally in 1927 by Davisson and Germer; they showed that interference patterns, a property of waves, can be obtained with material particles such as electrons.

Although Bohr’s model for the atom produced results that agree well with experimental spectroscopy, it was criticized for lacking the ingredients of a theory. Like the “quantization” scheme introduced by Planck in 1900, the postulates and assumptions adopted by Bohr in 1913

**●Concept of Particle-Wave properties**

According to classical physics, a particle is characterized by an energy  $E$  and a momentum  $p$ , whereas a wave is characterized by an amplitude and a wave vector  $k$  ( $k = 2\pi/\lambda$ ) that specifies the direction of propagation of the wave. Particles and waves exhibit entirely different behaviors; for instance, the “particle” and “wave” properties are mutually exclusive. We should note that waves can exchange *any* (continuous) amount of energy with particles.

In this section we are going to see how these rigid concepts of classical physics led to its failure in explaining a number of microscopic phenomena such as blackbody radiation, the photoelectric effect, and the Compton effect. As it turned out, these phenomena could only be explained by abandoning the rigid concepts of classical physics and introducing a new concept:

**the *particle* aspect of radiation.**

## Quantum Theory of Radiation

### ●Black body radiation experiment

Blackbody radiation is a common phenomenon that probably is familiar to you. When you see stars of different colors, when you observe an electric heating coil on a stove turn red, or when you observe a lightbulb, you are observing blackbody radiation. A blackbody is a device that converts heat into radiant energy. Heating an object to different temperatures causes that object to radiate energy of different wavelengths and therefore, different colors.

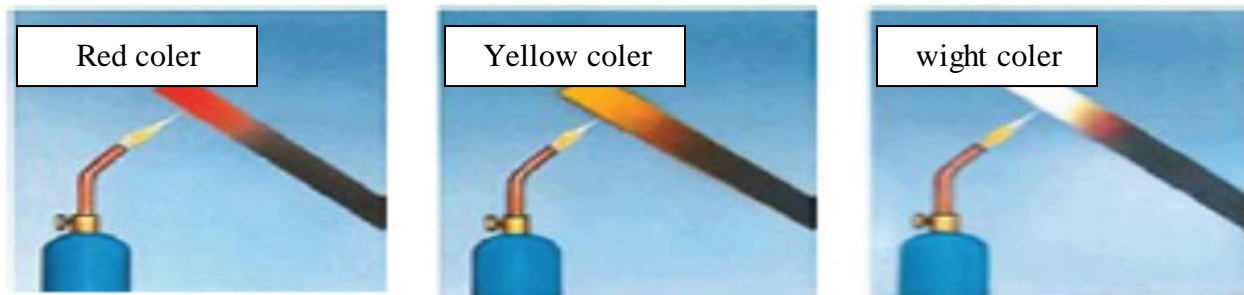

E.g. Heating a steel □ color changes by increasing temperature Color depends only on **temperature** *Not* on **type** of material.

Color observed due to characteristic distribution of light emission at a range of wavelengths If you know the color you know the temperature.

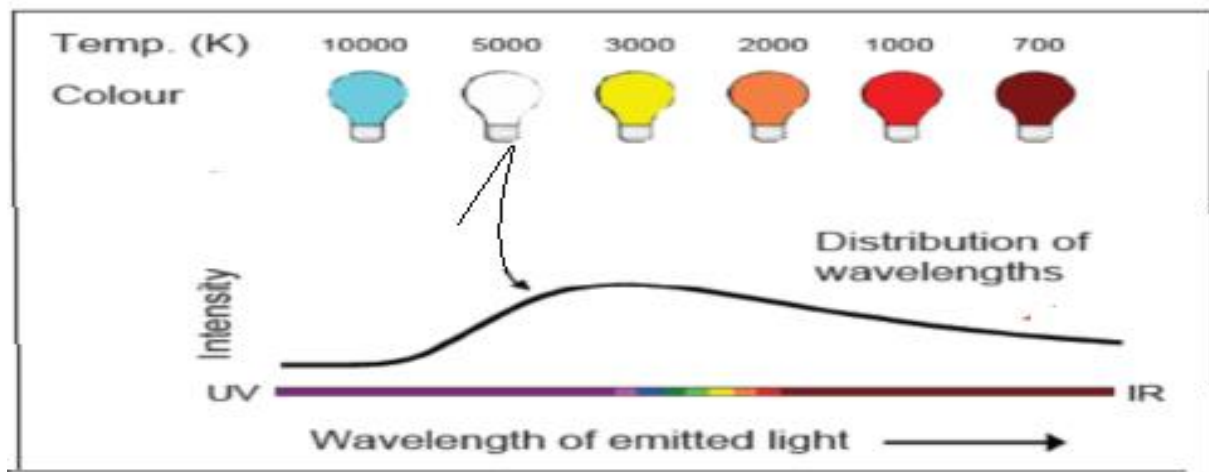

If you know the color you know the temperature

When black-body *heated* it is observed to *radiate* a spectrum of wavelengths having a characteristic *energy density* at each *frequency*.

Experience show that the temperature of a hot and a cold objects placed close to each other equalize in vacuum as well. All macroscopic objects in all temperature emit (and absorb) thermal radiation spontaneously. This radiation consists of electromagnetic waves.

The energy of the electromagnetic waves emitted by a surface, in unit time and in unit area, depends on the nature of the surface and on its temperature.

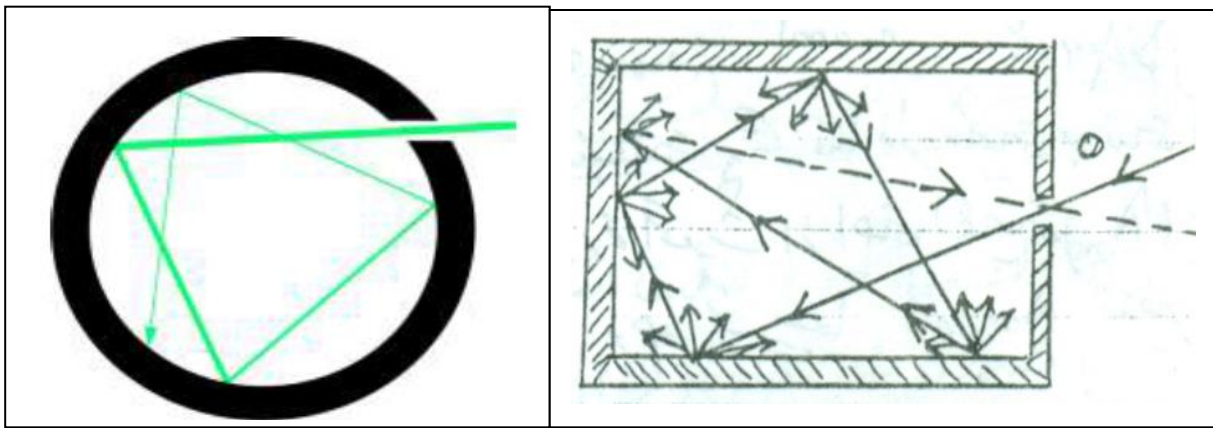

The thermal radiation emitted by many ordinary objects can be approximated as blackbody radiation. A perfectly insulated enclosure that is in thermal equilibrium internally contains black-body radiation and will emit it through a hole made in its wall, provided the hole is small enough to have negligible effect upon the equilibrium.

A black-body at room temperature appears black, as most of the energy it radiates is infra-red and cannot be perceived by the human eye. Black-body radiation has a characteristic, continuous frequency spectrum that depends only on the body's temperature.



## •Black Curve

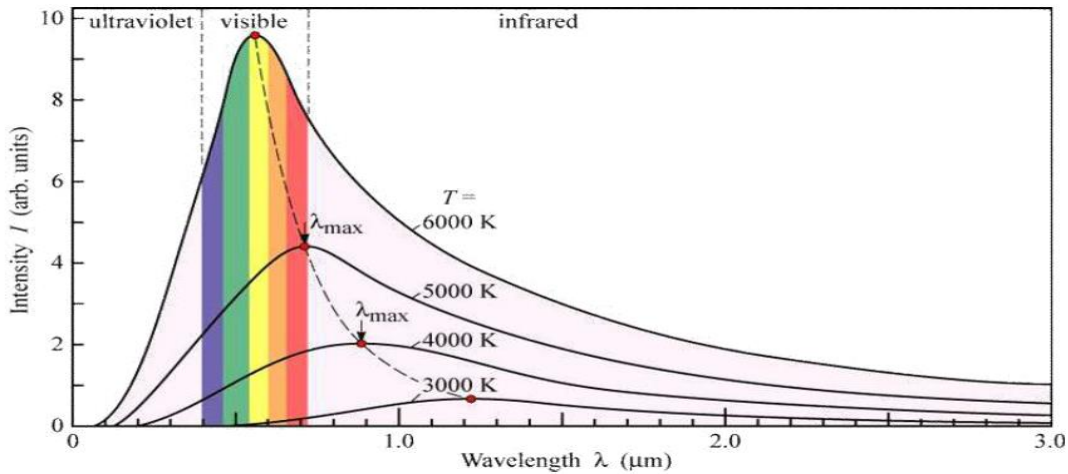

The spectrum is peaked at a characteristic frequency that shifts to higher frequencies (shorter wavelengths) with increasing temperature, and at room temperature most of the emission is in the infrared region of the electromagnetic spectrum.

**Wien's displacement law** indicates that the maximum of the energy distribution is displaced within the radiation spectrum of a blackbody in case of a change in temperature.

$$\lambda_{\text{max}} T = b \quad \dots\dots\dots(1)$$

where  $b$  is called Wien's displacement constant =  $2.89 \times 10^{-3} \text{ Km}$ .

**The Stefan–Boltzmann law** states that the power emitted by the surface of a black body is directly proportional to the fourth power of its absolute temperature and, of course, its surface area  $A$ :

$$E = \sigma T^4 A \quad \dots\dots\dots(2)$$

where  $\sigma \approx 5,67 \cdot 10^{-8} \text{ W}/(\text{m}^2 \text{K}^4)$  is the Stefan–Boltzmann constant.

It was impossible to explain the measured spectral emissivity distribution by the concepts and laws of classical physics. In 1900 Max Planck theoretically derived a formula, which accurately described the radiation. In order to do that, he had to suppose that **electromagnetic energy could be emitted not continuously, but only in quantized form**, in other words, the energy could only be a multiple of an elementary unit

$$E = h f \quad \dots\dots\dots(3)$$

where h is Planck's constant,  $h = 6,626 \cdot 10^{-34}$  Js. Planck's quantum hypothesis is a pioneering work, heralding advent of a new era of modern physics and quantum theory.

**•Number of Standing Wave:**

**The energy of incident electromagnetic**

**Wave  $E_1$  in x axes:**

$$E_1 = E_0 \cos(\omega t - K_x X) \dots\dots(1)$$

**The reverse electromagnetic wave**

**$E_2$  in oposit x axes:**

$$E_2 = -E_0 \cos(\omega t + K_x X) \dots\dots(2)$$

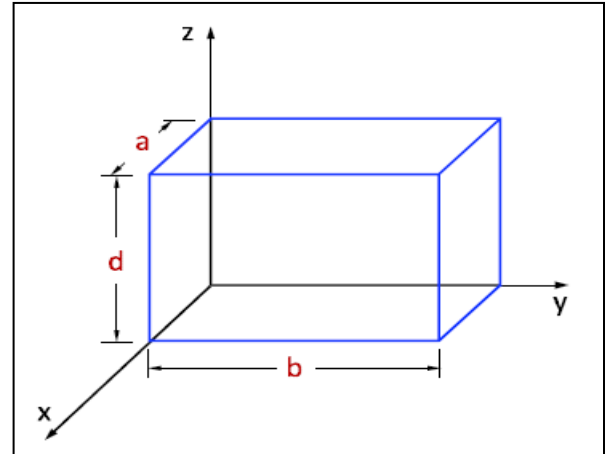

**Then the equation of the standing wave:**

$$E = E_1 + E_2 = E_0 [\cos(\omega t - K_x X) - \cos(\omega t + K_x X)] \dots\dots(3)$$

Using the following proberity kn Eq(3):

$$\cos A - \cos B = 2 \sin \frac{A+B}{2} \cdot \sin \frac{A-B}{2}$$

$$E = 2E_0 \sin \omega t \cdot \cos K_x X \dots\dots(4)$$

From the above digram, the standing wave in the x- direction between  $(0 < x < a)$ . Node formed at  $x=0$  and  $x=a$  (reverse side). Then  $E|_{x=a} = 0$

$$E|_{X = a} = 2E_0 \sin \omega t \cdot \cos K_x a = zero \dots\dots(5)$$

Then;  $\cos K_x a = zero \dots\dots(6)$

ie )  $K_x a = \pi, 2\pi, 3\pi, \dots\dots n\pi \dots\dots x \pi n_x = 1, 2,$

$$or \therefore K_x = \frac{\pi}{a} n_x \dots\dots(7)$$

Simalary, the wave number (K) in both y and z directions :

$$K_y = \frac{\pi}{b} n_y \dots\dots(8)$$

$$K_z = \frac{\Pi}{d} n_z \dots\dots\dots(9)$$

By Re-arranging these equations, we get the following :

$$n_x = \frac{a}{\pi} K_x$$

$$n_y = \frac{b}{\pi} K_y$$

$$n_z = \frac{d}{\pi} K_z \quad (10)$$

Where,  $n_x, n_y, n_z$  number of stasionary wave. By re-writing uicse eqs:

$$(dn_k)_x = \frac{a}{\pi} .dk_x$$

$$(dn_k)_y = \frac{b}{\pi} .dk_y$$

$$(dn_k)_z = \frac{d}{\pi} .dk_z \dots\dots\dots(11)$$

Then, the total number of standing wave :

$$\begin{aligned} dn_{k_x, k_y, k_z} &= \frac{abd}{\pi^3} .dk_x .dk_y .dk_z \\ &= \frac{V}{\pi^3} dk_x .dk_y .dk_z \dots\dots(12) \end{aligned}$$

$$K = \frac{2\pi}{\lambda} = \frac{2\pi\nu}{c} \therefore dK = -\frac{2\pi}{\lambda^2} d\lambda \dots\dots(13)$$

By substituting from (13) in (12), we get :

$$dn_\nu = V \cdot \frac{\nu^2}{2\pi^2} \cdot \frac{d\nu}{c^3} \dots\dots(14)$$

The number of standing wave per uint volum V :

$$dn_\nu = \frac{\nu^2}{2\pi^2} \cdot \frac{d\nu}{c^3} \dots\dots(15) \quad \text{OR}$$

Taking the direction of polarization between the incident and reverse EM wave

$$dn_\nu = \frac{\nu^2}{\pi^2} \cdot \frac{d\nu}{c^3}$$

$$n(\nu) = \frac{8\pi\nu^2}{c^3} \quad \& \quad n(\lambda) = \frac{8\pi}{\lambda^4} \quad \longrightarrow \quad (16)$$

## 2- Classical and Quantum Postulations for calculating average Energy

### Classical Explanation (Rayleigh-Jeans law)

They supposed that

1. Blackbody radiation is coming from standing electromagnetic waves in the cavity that are in thermal equilibrium with the vibrating atoms (or electrons) in the walls
2. The atoms in the blackbody are assumed to vibrate like harmonic oscillators
3. according to the principle of equipartition of energy an oscillator in thermal equilibrium with its environment should have an average energy equal to  $kT$

$$E = k_B T \quad \text{-----}(1)$$

4. **Rayleigh-Jeans** using classical theory have calculated number of standing waves  $n(\lambda)$  or  $n(\nu)$  :

$$n(\lambda) = \frac{8\pi}{\lambda^4} \quad \text{Or} \quad \text{-----}(2)$$

$$n(\nu) = \frac{8\pi\nu^2}{c^3}$$

From both Eqs

$$n(\nu) = n(\lambda) \cdot \left| \frac{d\lambda}{d\nu} \right| = n(\lambda) \cdot \frac{c}{\nu^2} \quad \text{-----}(3)$$

Assigning energy to the electromagnetic standing waves in a cavity draws on the principle of equipartition of energy. Each standing wave mode will have average energy  $kT$  where  $k$  is Boltzmann's constant and  $T$  the temperature in Kelvins. Letting  $u$  represent the energy density:

$$R = I_{\nu} d\nu = E dn_{\nu} = k_B T \frac{8\pi}{\lambda^4} \text{-----(4)}$$

And the **Intensity of thermal radiation** and the **wavelength** of the radiation is (for unit volume) :

$$I(\lambda, T) = k_B T \cdot n(\lambda) = \frac{8\pi}{\lambda^4} k_B T \quad (5)$$

This is an important relationship in classical electromagnetic cavity theory. It can also be expressed in terms of the frequency  $\nu$  by making use of the chain rule and the wave relationship:

$$\rho(\nu, T) d\nu = \frac{8\pi kT}{c^3} \nu^2 d\nu \quad (6)$$

This is known as the Rayleigh-Jeans law. A clear implication of this law is that as the **frequency** becomes **larger**, the **energy density increases** as the square of the frequency.

Where,

$I(\nu, T)$  = is the **Intensity of thermal radiation**

$\nu$  = is the frequency of *emitted* radiation,

$T$  = is the temperature of the blackbody,

$K$  = is Boltzmann's constant, and

$c$  = is the speed of light.

The disagreement of Ryligh iJeen's law at short uv wavelength is called **ultra-violet catastrophe**.

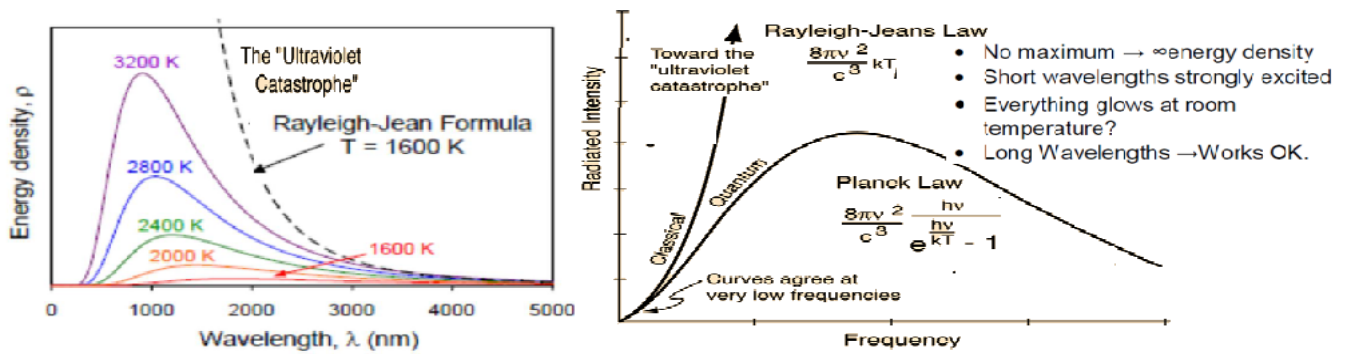

The Rayleigh-Jeans curve agrees with the Planck radiation formula for long wavelengths, low frequencies

**Notice that:**

- 1- Rayleigh Jeans law is valid only at low-frequency limit  $h\nu \ll KT$ .
- 2- Intensity of radiation is proportional to frequency squared because the volume of a cavity in three dimensions is proportional to frequency squared.
- 3- It is assumed that all modes have , the classical assumption that breaks down at high frequencies.
- 4-  $I_\nu$  diverges at high frequencies. This is called the "ultraviolet catastrophe".
5.  $I_\nu$  is independent of direction.

**2-Second Classical Model By (Wein's postulation)**

The second model suggested by Wien used the Newtonian view of radiation as a flux of particles. Applying to such particles Boltzmann's statistical treatment, Also Wien Has agreed with

Rayleigh-Jeans model, that EM wave generated by oscillators modes. These oscillators consider energy carriers for EM waves. Applying Maxwell-Boltzmann's statistical distribution law:

$$\Delta N = N_0 e^{-E_\nu / KT} \dots\dots\dots(1)$$

Where;

$N_0$  is the total number of oscillating carriers,  $\Delta N$  is the number of oscillating carriers which have energy  $E_\nu = h\nu$ , and  $K$  is the Boltzmann's constant.

Equation (1) can be written as :

$$\Delta N = N_0 e^{-h\nu / KT} \dots\dots\dots(2)$$

According to these assumptions , the average energy  $\bar{E}$  for each oscillator:

$$\bar{E} = E_0 / \Delta N \dots\dots(3)$$

$$\bar{E} = \frac{\Delta N}{N_0} \cdot E_0 = E_0 \cdot e^{-E_0/KT} = \bar{E} = E_0 \cdot e^{-h\nu/KT} \dots\dots(3)$$

And we have before number of standing wave (No. of Oscillators ):

$$n(\nu) = \frac{8\pi\nu^2}{c^3}$$

Then; substituting from eq (2) and (3) in to the following Eq. we get :

$$R = I_\nu d\nu = \bar{E} dn_\nu = h\nu \cdot e^{-h\nu/KT} \cdot \left(\frac{8\pi\nu^2}{c^3}\right) \dots\dots(4)$$

$$I_{(\nu,T)} = \frac{8\pi h\nu^3}{c^3} \cdot e^{-h\nu/KT} \dots\dots(5)$$

$$I(\lambda,T) = a \lambda^{-5} \cdot e^{-b/\lambda T} \dots\dots(6)$$

This is the Wein radiation Law

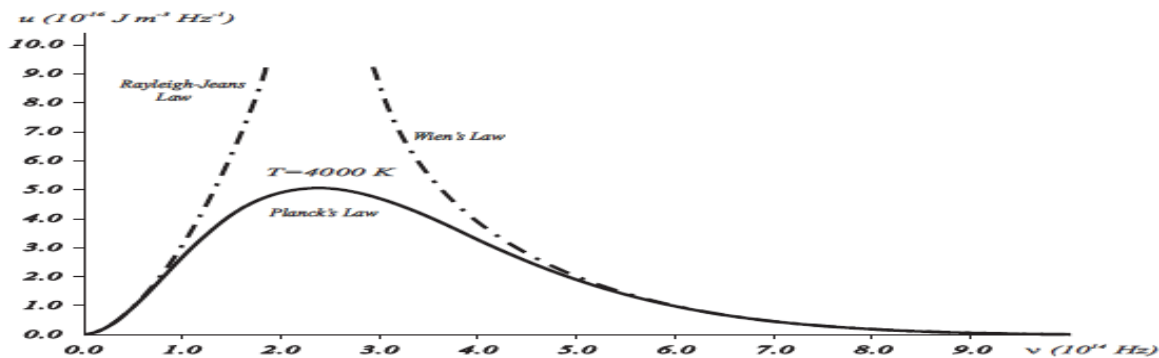

Figure . Comparison of various spectral densities: while the Planck and experimental distributions match perfectly (solid curve), the Rayleigh-Jeans and the Wien distributions (dotted curves) agree only partially with the experimental distribution.

**Notice that:**

1- Wein's law is valid only at high-frequency limit  $h\nu \gg KT$ .

2-Intensity of radiation is proportional to cubic frequency because the volume of a cavity in three dimensions is proportional to frequency to the order three.

3-It is assumed that all modes have , the classical assumption that breaks down at low frequencies.

4-  $I_\nu$  diverges at low frequencies.

5.  $I_\nu$  is independent of direction.

### **Quantum Postulation (Max Planck's Model)**

Max Planck started from the standard assumption, that :

1. blackbody could be modeled as a collection of oscillators
2. Planck postulated that possible mode energies are not continuously distributed, they take on a discrete quantized energies and must satisfy

$$E = h\nu, 2h\nu, 3h\nu, \dots, nh\nu \quad \text{-----(1)}$$

Suppose that,  $N_0$  is the number of oscillators have energy  $E = h\nu$  equal zero, and other oscillators have energies  $2h\nu, 3h\nu, \dots$  and they obey Boltzmann distribution law as follow:

$$\begin{aligned} N(h\nu) &= N_0 \cdot e^{-h\nu/KT} \\ N(2h\nu) &= N_0 \cdot e^{-2h\nu/KT} \\ &\text{-----} \\ &\text{-----} \dots \dots \dots (2) \\ N(nh\nu) &= N_0 \cdot e^{-nh\nu/KT} \end{aligned}$$

Then, Total number of oscillators becomes :

$$\begin{aligned} N &= N_0 + N_0 \cdot e^{-h\nu/KT} + N_0 \cdot e^{-2h\nu/KT} + \dots + N_0 \cdot e^{-nh\nu/KT} \\ &= N_0 \left[ 1 + e^{-h\nu/KT} + e^{-2h\nu/KT} + \dots + e^{-nh\nu/KT} \right] \dots \dots \dots (3) \\ N &= N_0 \left( 1 - e^{-nh\nu/KT} \right)^{-1} \end{aligned}$$

**Energies of different oscillators = (number of oscillators) x (energy of one oscillator) eg**



$$\begin{aligned} \therefore E_1 &= h\nu \cdot N_0 e^{-h\nu/KT} \\ E_2 &= 2h\nu \cdot N_0 e^{-2h\nu/KT} \\ E_3 &= 3h\nu \cdot N_0 e^{-3h\nu/KT} \\ &\text{-----} \\ E_n &= nh\nu \cdot N_0 e^{-nh\nu/KT} \text{-----}(4) \end{aligned}$$

Then the energy of all oscillators becomes :

$$\begin{aligned} E &= E_1 + E_2 + \dots + E_n \\ &= h\nu \cdot N_0 e^{-\frac{h\nu}{KT}} + 2h\nu \cdot N_0 e^{-\frac{2h\nu}{KT}} + \dots + nh\nu \cdot N_0 e^{-\frac{nh\nu}{KT}} \\ E &= h\nu \cdot N_0 e^{-\frac{h\nu}{KT}} \left( 1 + e^{-\frac{h\nu}{KT}} + e^{-\frac{2h\nu}{KT}} + \dots \right) \dots\dots\dots(5) \end{aligned}$$

**Average energy =  $\frac{\text{Total energy}}{\text{Number of oscillators}}$**

$$\begin{aligned} \bar{E} &= \frac{E}{N} = h\nu \cdot e^{-\frac{h\nu}{KT}} \frac{\left[ N_0 \left( 1 + e^{-\frac{h\nu}{KT}} + e^{-\frac{2h\nu}{KT}} + \dots \right) \right]}{N_0 \left( 1 + e^{-\frac{h\nu}{KT}} + e^{-\frac{2h\nu}{KT}} + \dots \right)^{-1}} \\ \bar{E} &= \frac{h\nu \cdot e^{-\frac{h\nu}{KT}}}{\left( 1 + e^{-\frac{h\nu}{KT}} + e^{-\frac{2h\nu}{KT}} + \dots \right)} = \frac{h\nu}{\left( e^{h\nu/KT} - 1 \right)} \dots\dots\dots(6) \end{aligned}$$

$$\langle E \rangle = \frac{h\nu}{e^{h\nu/kT} - 1}$$

This is the average energy per "mode" or "quantum" is the energy of the quantum times the probability that it will be occupied. The number of modes per unit volume per unit wavelength or frequency is expressed as :

$$\rho(\nu) = \frac{dn_s}{d\nu} = \frac{8\pi}{c^3} \nu^2 \quad \rho(\lambda) = \frac{dn_s}{d\lambda} = \frac{8\pi}{\lambda^4}$$

gives the energy density, the Planck radiation formulas :

**Intensity per unit volume per unit wavelength**

$$I(\lambda, T) = \frac{8\pi hc}{\lambda^5} \frac{1}{e^{hc/\lambda kT} - 1}$$

**Intensity per unit volume per unit frequency**

$$I(\nu, T) = \frac{8\pi h \nu^3}{c^3} \frac{1}{e^{h\nu/kT} - 1}$$

the exponential dominates the cubic in  $\nu$  and so  $\rho$  goes to zero. So using quantization is required, for correct behavior at *high* frequencies. **(Energy is quantized)**

The constant  $h$  has come to be called Planck's constant, and its value is  $6.626 \times 10^{-34}$  J s.

**Relation between classical and quantum postulations**

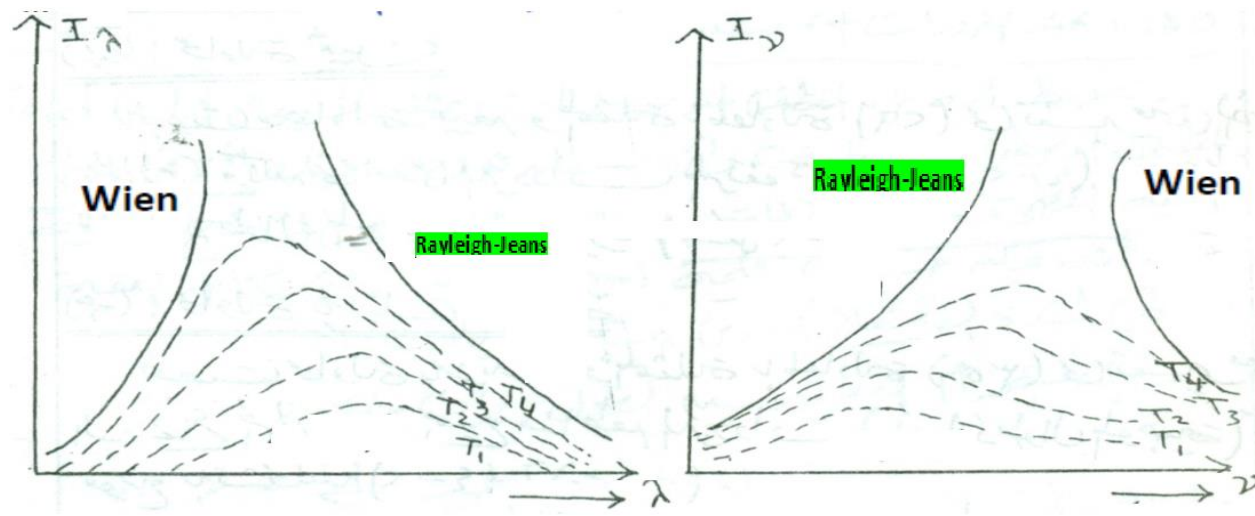

- Planck result fits experiment perfectly
- R-J is accurate in infrared but diverges in ultraviolet
- Wien works well except in the infrared

1- At low frequencies  $\left(\frac{h\nu}{kT} \ll 1\right)$ ;

Using the series expansion for the exponential

$$\text{when } \frac{h\nu}{kT} \ll 1, \text{ Then } \exp \frac{h\nu}{kT} \Rightarrow \left(1 + \frac{h\nu}{kT}\right)$$

we recover the Rayleigh-Jeans formula.

$$\rho(\nu, T) d\nu = \frac{8\pi kT}{c^3} \nu^2 d\nu$$

2- At high frequencies  $\left(\frac{h\nu}{kT} \gg 1\right)$ ; then  $\exp(h\nu/kT) \gg 1$

We can neglect the integer number one in planck's law. So we get:

$$\rho(\nu, T) d\nu = \frac{8\pi h\nu^3}{c^3} e^{-h\nu/kT} d\nu$$

We recover ween's formula.

The exponential dominates the cubic in  $\nu$  and so  $I_\nu$  goes to zero. So using quantization is required, for correct behavior at *high* frequencies. (**Energy is quantized**).

Expression of the energy density  $\rho(\nu, T)$  in terms of wavelength  $\rho(\lambda, T)$

$$\rho(\nu, T) d\nu = \frac{8\pi h\nu^3}{c^3(e^{h\nu/kT} - 1)} d\nu$$

$$\nu = \frac{c}{\lambda} \Rightarrow d\nu = \frac{-c}{\lambda^2} d\lambda$$

$$\rho(\lambda, T) d\lambda = \frac{8\pi hc}{\lambda^5(e^{hc/\lambda kT} - 1)} d\lambda$$

Wien displacement law

He states that the wavelength distribution of thermal radiation from a black body at any temperature has essentially the same shape as the distribution at any other temperature, except that each wavelength is displaced on the graph.

He states that if  $\lambda_{\max}$  is the wavelength at which  $\rho(\lambda, T)$  is a maximum, and so

$$\frac{d(\rho(\lambda, T))}{d\lambda} = \frac{d\left(\frac{8\pi hc}{\lambda^5(e^{hc/\lambda kT} - 1)}\right)}{d\lambda} = 0$$

By differentiation of the above equation with respect to  $\lambda$  and substitution by the constants value ( $h, c, k$ ) it is found that

$$\lambda_{max}T = 2.897 \times 10^{-3}$$

Example: calculate the temperature used to heat a black body to emit radiation at 400 nm

$$T = \frac{2.897 \times 10^{-3}}{\lambda_{max}} = \frac{2.897 \times 10^{-3}}{400 \times 10^{-9}} = 7242.5 \text{ K}$$

### Stefan-Boltzmann law

The law states that the total energy radiated per unit surface area of a black body per unit time (also known as the black-body irradiance or emissive power),  $P$ , is directly proportional to the fourth power of the black body's thermodynamic temperature  $T$ .

$$P = \sigma T^4$$

$$\text{Where } \sigma = 5.6697 \times 10^{-8} \text{ J s}^{-1} \text{ m}^{-2} \text{ K}^{-4}$$

By integration the Plank's law to get the total energy density so

$$E = \int_0^{\infty} \rho(\nu, T) d\nu = \int_0^{\infty} \frac{8\pi h\nu^3}{c^3(e^{h\nu/kT} - 1)} d\nu$$

$$\therefore E = \frac{8\pi^5 k^4 T^4}{15h^3 c^3}$$

The relation between the emissive power and the total energy density is

$$P = \frac{c}{4} E$$

$$\therefore E = \frac{4}{c} \times \frac{2\pi^5 k^4}{15h^3 c^2} T^4 \Rightarrow \frac{c}{4} E = \frac{2\pi^5 k^4}{15h^3 c^2} T^4$$

$$\therefore P = \frac{2\pi^5 k^4}{15h^3 c^2} T^4 = \sigma T^4$$

By substitution by the constants value ( $\pi, h, c, k$ ) it is found that

$$\sigma = 5.670 \times 10^{-8} \text{ J s}^{-1} \text{ m}^{-2} \text{ K}^{-4}$$

### • Total Energy

By integration the Plank's law to get the total energy density  $E$  :

$$E = \int_0^{\infty} I(\nu, T) = \int_0^{\infty} \frac{h\nu^3 / \pi^2 c^3}{\left[ \exp\left(\frac{h\nu}{kT}\right) - 1 \right]} d\nu$$

$$E = \frac{8\pi^2 k^4 T^4}{15h^3 c^3}$$

The relation between the emissive power and the total energy density is :

$$P = \frac{c}{4} E \rightarrow E = \frac{4}{c} P$$

$$P = \frac{2\pi^5 k^4}{15h^3 c^3} T^4 = \sigma T^4$$

By substitution by the constants value ( $\pi, h, c, k$ ) it is found that

### • Comparison between classical and quantum theories for average energy

$$\sigma = 5.6697 \times 10^{-8} \text{ J} \cdot \text{S}^{-1} \cdot \text{m}^{-2} \cdot \text{K}^{-4}$$

Radiation modes in a hot cavity provide a test of quantum theory

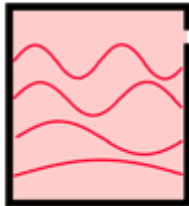

	#Modes per unit frequency per unit volume	Probability of occupying modes	Average energy per mode
CLASSICAL	$\frac{8\pi\nu^2}{c^3}$	Equal for all modes	$kT$
QUANTUM	$\frac{8\pi\nu^2}{c^3}$	Quantized modes: require $h\nu$ energy to excite upper modes, less probable	$\frac{h\nu}{e^{\frac{h\nu}{kT}} - 1}$

## Photoelectric Effect Phenomenon

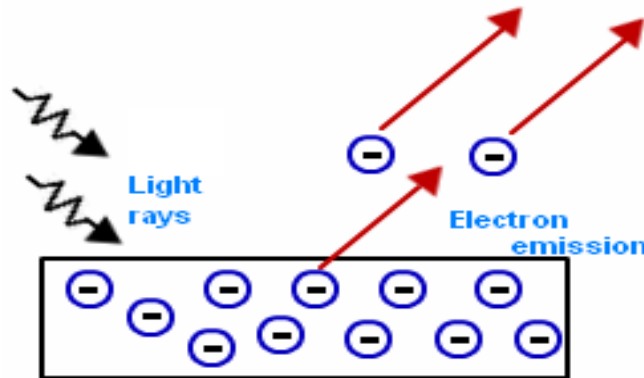

The photoelectric effect was discovered by Hertz in 1887 as he confirmed Maxwell's electromagnetic wave theory of light. In the photoelectric effect, incident electromagnetic radiation (light) shining upon a material transfers energy to electrons so that they can escape from the surface of the material.

Electromagnetic radiation acts on electrons within metals, increasing their total energy. Because electrons in metals are weakly bound, you would expect that light would give electrons enough extra kinetic energy to allow them to escape from the metal's surface. The released electrons are often referred to as photoelectrons. The minimum extra kinetic energy that allows electrons to escape the material is the called the work function  $W_{min}$ . The work function is the minimum binding energy of an electron to the material.

### • Classical explanation of photoelectric effect

When light is incident on some metal surface electron is emitted from the surface. This phenomenon is called photoelectric effect. Classical wave theory of light cannot explain the features of this phenomenon. The main features that cannot be explained in terms of classical wave theory of light.

Wave theory requires that the oscillating electric vector  $E$  of light waves increase in amplitude as the intensity of the light beam is increased. Since the force applied to the electron is  $eV$ , this suggests that the kinetic energy of the photoelectrons should also increase as the light beam is made more intense. However, the maximum kinetic energy of the emitted photoelectron is independent of the light intensity. Thus, the minimum potential  $V_s$  at which

photocurrent drops to zero must equal (in eV) the kinetic energy ( $K_{\max}$ ) of the fastest electrons emitted by the photoelectric process.

$$K_{\max} = eV_s = \frac{1}{2} m v_{\max}^2$$

So far everything that has been said is correct experimentally and agrees in principle with concepts of classical physics. But let us analyze the detail of the process according to classical electromagnetic theory. In these terms the incident electromagnetic radiation is considered as wave of oscillation frequency  $f$  and electric field amplitude  $\epsilon_0$ . The intensity of the wave is proportional to the modulus square of the amplitude:

$$I = \alpha \epsilon_0^2$$

The electron, being bound to the surface, has a surface binding energy  $\phi$  which is termed as the work function for the metal. Thus in a time interval  $t$ , the amount of energy received by a surface atomic layer of area  $A$  is  $IAt$ . This energy is partially used to overcome the Work Function and the rest appears as kinetic energy for the emitted electron

$$K = I.A.t - \phi = \alpha \epsilon_0^2 t - \phi$$

**This classically derived relation implies the following assumptions:**

- 1- *Kinetic energies of electrons emitted are independent of the radiation frequency.*
- 2- *Kinetic energies of electrons emitted are directly related to the intensity of the incident electromagnetic radiation (i.e. by increasing the intensity electrons can be liberated irrespective of the radiation frequency, and  $K_{\max}$  may be thus increased.*
- 3 . *According to the wave theory the photoelectric effect should occur for any frequency of light, provided only that the light is intense enough to give the energy needed to eject the photoelectrons.* However, it is experimentally found that there exists a characteristic cutoff frequency  $f_0$  below which photoelectric effect does not occur, no matter how intense the illumination.
4. *According to wave theory a measurable time lag between the time when light starts to impinge on the surface and the ejection of photoelectron should exist. But no detectable time lag has ever measured. But these features can be explained by classical wave theory of light*

### ● Experimental results of the photoelectric effect

Experiments around 1900 showed that when visible and ultraviolet light were incident upon a clean metal surface, electrons were ejected from the surface. Experiments used an evacuated tube known as a photocell. The light incident upon an emitter electrode ejected the electrons, producing an electric current  $I$  that was measured using a sensitive Ameter. A voltage was applied between the emitter and collector electrodes.

The polarity of this voltage could be reversed to either accelerate the photoelectrons from the emitter to the collector or retard their movement and prevent them reaching the collector electrode. When the applied voltage was such that collector was negative, it could be adjusted to set the current measured by the Ameter to zero ( $I = 0$ ). This voltage is called the **stopping voltage**  $V_s$ .

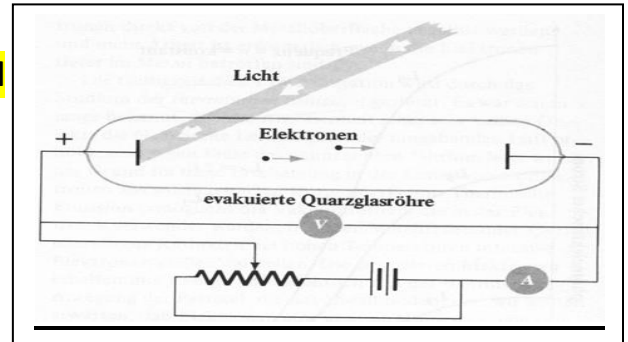

Classical theory on electromagnetic radiation predicts that electrons would be ejected from a material as the electrons absorb energy from the incident electromagnetic wave.

**Key experimental finding (many of which were very surprising in terms of classical physics predictions):**

1. The kinetic energies of the photoelectrons are independent of the intensity of the incident light. A given stopping voltage  $V_s$  stops all photoelectrons from reaching the collecting electrode ( $I = 0$ ), no matter what the intensity of the light. For a given light intensity, there is a maximum photocurrent reached as the applied voltage increases from negative to positive.

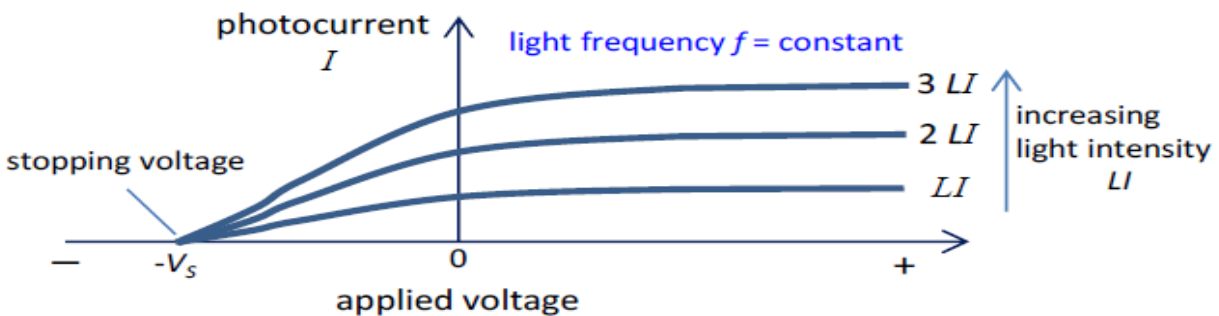



⊗ Classical theory: The greater the amplitude of the wave then the greater the energy and intensity of the wave. Therefore, electrons should be ejected with more kinetic energy as the light intensity increases. **Key finding #1** can't be explained by classical theory because the maximum kinetic energy of the photoelectrons depends on the value of the light frequency and **not** the intensity.

2. The maximum kinetic energy of the photoelectrons depends only of the frequency  $f$  of the light for a given material. Hence, a different stopping voltage is required for different frequencies: the greater the frequency, the larger the stopping voltage to reduce the photocurrent to zero. The value of  $V_s$  depends on the frequency  $f$  of the light and not on its intensity  $LI$ .

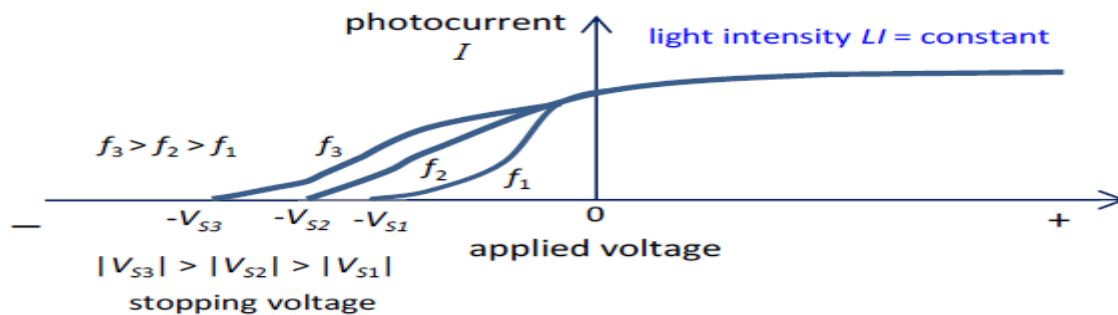

3. If the frequency of the incident is too small, zero electrons are ejected from the emitter electrode, no matter how large the intensity of the incident light. A photocurrent is only observed when the frequency of light is greater than some threshold value, called the **critical frequency**  $f_c$ . The smaller the work function  $W_{min}$  of the material, the smaller the value of the critical frequency  $f_c$ .

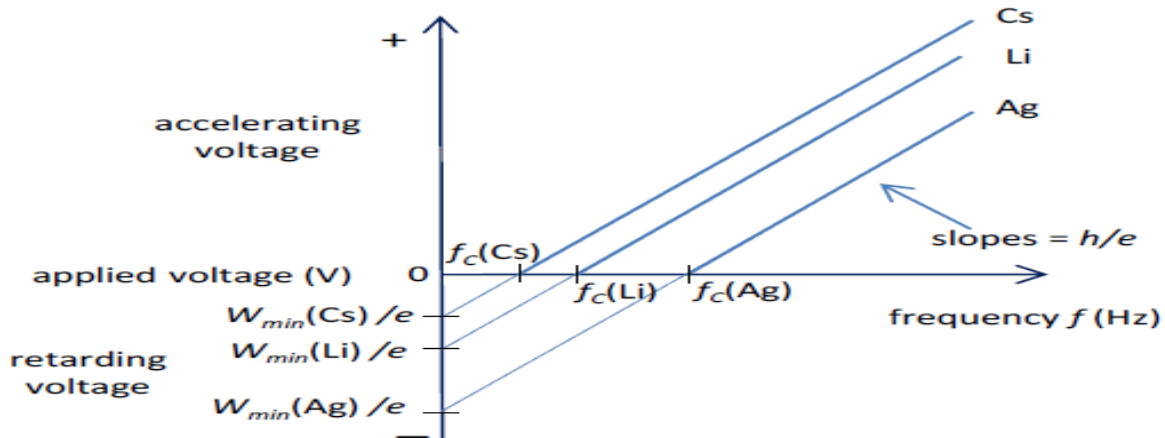

⊗ **Classical theory:** the existence of a threshold frequency is completely inexplicable as are the results for the linear relationship between applied voltage

and frequency as shown in the above graph. This graph investigates the relation between the kinetic energy of the fastest electrons emitted ( $K_{\max}$ ) and the frequency of the incident radiation. From these experimental results we conclude the following :

- $K_{\max}$  is independent of the intensity of the incident electromagnetic radiation (curve 5-a). The intensity change changes the number of electrons emitted (current) but has no effect on the kinetic energies of the emitted electrons.
- $K_{\max}$  is linearly related to the frequency of the incident electromagnetic radiation (curve 5-b) such that below some characteristic frequency ( $f_0$ ) no electrons are emitted irrespective of the radiation intensity. The characteristic frequency differs for different metals and is termed the **threshold frequency**.

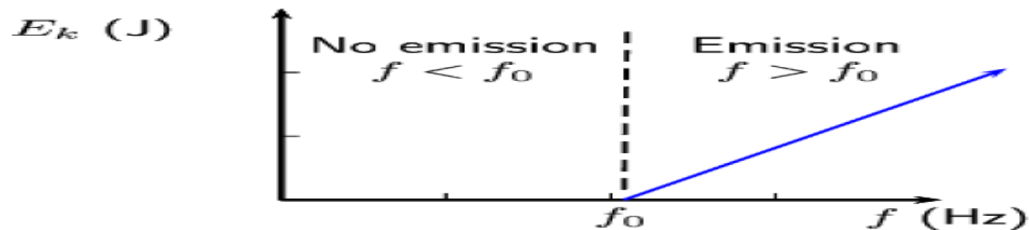

- There is no measurable time lag for the photoelectrons to be emitted, provided the radiation frequency is above the threshold frequency for the metal under consideration.

Experimental results, as seen above, are all in direct conflict with classical electromagnetic theory, hence, a new model is required to remove this discrepancy.

4. When photoelectrons are emitted from the emitter electrode, their number is proportional to the intensity of the light, hence, maximum photocurrent is proportional to the light intensity.

⊠ Classical theory does predict that the number of photoelectrons ejected will increase with intensity.

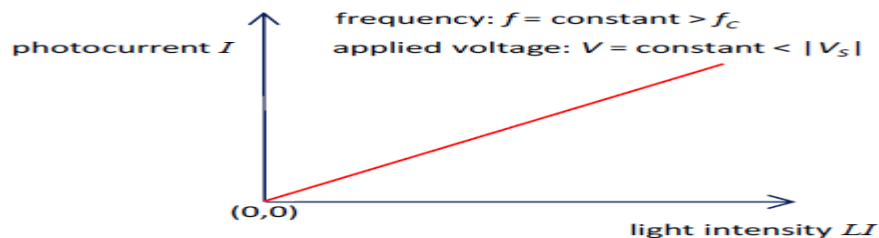

5. Photoelectrons are emitted almost instantly ( $< 3 \times 10^{-9}$  s) following the illumination of the emitter electrode, and this time is independent of the intensity of the light.

⊠ Classical theory would predict that for low light intensities, a long time would elapse before any one electron could obtain sufficient energy to escape.

### **Quantum Interpretation and Einstein's Theory**

To explain the experimental observations of the photoelectric effect, it was necessary to model the incident electromagnetic wave as a stream of particles. The light interacting with the electrons in the material is like a stream of bullets hitting a target.

*Einstein took Planck's idea about quantization of energy for an oscillator a step further and suggested that the electromagnetic radiation field is itself quantized and that the energy of a beam of light spreading out from a source is not continuously distributed over an increasing space but consists of a finite number of energy quanta which are localized at points in space which move without dividing, and which can only be produced and absorbed as complete units. These quantized energy units of light are called **photons**. Each individual photon has an energy quantum :*

$$E = hf$$

**Einstein's proposal meant that as well as light behaving as a wave as shown by its interference effects, light must also have a particle-like aspect.**

**To explain the photoelectric effect, each photon delivers its entire energy ( $hf$ ) to a single electron in the material. For an electron to be ejected from the material, the photon's energy must be greater than the energy binding the electron to the material. If the photons energies are less than the binding energies, zero electrons can be emitted from the material, irrespective of how intense the incident light beam. Hence, using the principle of conservation of energy :**

Energy before (photon)  $E$  = Energy after (ejection of electron from material  $W$  + K.E. of ejected electron  $E_k$ )

$$E = hf = w + E_k \dots\dots\dots(2)$$

When the energy required to remove an electron from the material is a minimum  $W_{min}$ , ( $W_{min}$  is the **work function** of the material), the kinetic energy of the ejected electron will be a maximum  $E_{Kmax}$ , hence,

$$E = hf = w_{min} + E_{k \max} \dots\dots\dots(3a)$$

$$E = hf = w_{min} + (1/2) m_e V_{\max}^2 \dots\dots\dots(3b)$$

The applied potential can be used to retard the electrons from reaching the collector. The retarding voltage, when the photocurrent  $I$  becomes zero, is called the **stopping voltage** and its value can be used to measure the maximum kinetic energy of the photoelectrons :

$$eV_s = w_{min} + (1/2) m_e V_{\max}^2 \dots\dots\dots(4)$$

Einstein's quantum interpretation can explain all the details of photoelectric effect experiments.

**Key findings #1 and #2** are easily explained because the kinetic energy of the electrons does not depend upon the light intensity at all, but only on the light frequency and work function of the material :  $(1/2) m_e V_{\max}^2 = hf - w_{min} \dots\dots\dots(5)$

A potential slightly more positive than  $-VS$  will not be able to repel all electrons and a small current will be measured. As the applied voltage increases in a positive sense the current will increase until most of the electrons will be collected and the current will be at a maximum. If the light intensity increases, there will be more photons ejecting electrons, and therefore a higher photocurrent as shown in graph for #1. If a different frequency is used, then a different stopping voltage is needed to stop the most energetic photoelectrons. The higher the incident light frequency, then, the greater the magnitude of the stopping voltage, as shown in graph for #2.

**Key finding #3:** Equations (3) and (4) can be rearranged to give a linear relationship between the stopping voltage and the light frequency, hence the quantum explanation accounts for the results shown in graph #3.

$$V_s = (hf/e) - (w_{min}/e) \dots\dots\dots(5)$$

From the linear graph of equation (5) when  $V_s$  is plotted against  $f$ , the slope  $(h/e)$  can be used to estimate the value of Planck's constant  $h$  and the y-intercept  $(W_{min}/e)$  to give the value of the work function  $W_{min}$  of the material. The x-intercept corresponding to  $V_s = 0$  gives the value for the critical frequency  $f_c = W_{min}/h$ .

**Key finding #4:** The number of photons increases in proportion to the increase in light intensity. Hence, increasing light intensity means more photons, hence more photoelectrons released and a higher photocurrent measured as shown in graph #4.

**Key finding #5:** Electrons will be ejected from the material without delay because an electron will absorb all the energy from an individual photon, thus, it is “kicked out” almost immediately.

## Solved Problems

**Example: 1** The work function of a substance is  $4.0 \text{ eV}$ . The longest wavelength of light that can cause photoelectron emission from this substance is approximately

- (a)  $540 \text{ nm}$     (b)  $400 \text{ nm}$     (c)  $310 \text{ nm}$     (d)  $220 \text{ nm}$

**Solution :** (c) By using  $\lambda_0 = \frac{12375}{W_0(\text{eV})} \Rightarrow \lambda_0 = \frac{12375}{4} = 3093.7 \text{ \AA} \approx 310 \text{ nm}$

**Example: 2** Photo-energy  $6 \text{ eV}$  are incident on a surface of work function  $2.1 \text{ eV}$ . What are the stopping potential

- (a)  $-5 \text{ V}$     (b)  $-1.9 \text{ V}$     (c)  $-3.9 \text{ V}$     (d)  $-8.1 \text{ V}$

**Solution :** (c) By using Einstein's equation  $E = W_0 + K_{\max} \Rightarrow 6 = 2.1 + K_{\max} \Rightarrow$

$$K_{\max} = 3.9 \text{ eV} \quad \text{Also} \quad V_0 = -\frac{K_{\max}}{e} = -3.9 \text{ V.}$$

**Example: 3** When radiation of wavelength  $\lambda$  is incident on a metallic surface the stopping potential is  $4.8 \text{ volts}$ . If the same surface is illuminated with radiation of double the wavelength, then the stopping potential becomes  $1.6 \text{ volts}$ . Then the threshold wavelength for the surface is

- (a)  $2\lambda$     (b)  $4\lambda$     (c)  $6\lambda$     (d)  $8\lambda$

**Solution :** (b) By using  $V_0 = \frac{hc}{e} \left[ \frac{1}{\lambda} - \frac{1}{\lambda_0} \right]$   $4.8 = \frac{hc}{e} \left[ \frac{1}{\lambda} - \frac{1}{\lambda_0} \right]$  .....(i) and  $1.6 = \frac{hc}{e} \left[ \frac{1}{2\lambda} - \frac{1}{\lambda_0} \right]$  ..... (ii)

**From equation (i) and (ii)**  $\lambda_0 = 4\lambda$ .

**Example: 4** When radiation is incident on a photoelectron emitter, the stopping potential is found to be  $9 \text{ volts}$ . If  $e/m$  for the electron is  $1.8 \times 10^{11} \text{ Ckg}^{-1}$  the maximum velocity of the ejected electrons is

- (a)  $6 \times 10^5 \text{ ms}^{-1}$     (b)  $8 \times 10^5 \text{ ms}^{-1}$     (c)  $1.8 \times 10^6 \text{ ms}^{-1}$     (d)  $1.8 \times 10^5 \text{ ms}^{-1}$

**Solution :** (c)  $\frac{1}{2} m v_{\max}^2 = eV_0 \Rightarrow v_{\max} = \sqrt{2 \left( \frac{e}{m} \right) \cdot V_0} = \sqrt{2 \times 1.8 \times 10^{11} \times 9} = 1.8 \times 10^6 \text{ m/s}.$

**Example:5** The lowest frequency of light that will cause the emission of photoelectrons from the surface of a metal (for which work function is  $1.65 \text{ eV}$ ) will be

- (a)  $4 \times 10^{10} \text{ Hz}$     (b)  $4 \times 10^{11} \text{ Hz}$     (c)  $4 \times 10^{14} \text{ Hz}$     (d)  $4 \times 10^{-10} \text{ Hz}$

**Solution :** (c) Threshold wavelength  $\lambda_0 = \frac{12375}{W_0(\text{eV})} = \frac{12375}{1.65} = 7500 \text{ \AA}.$

$\therefore$  so minimum frequency  $\nu_0 = \frac{c}{\lambda_0} = \frac{3 \times 10^8}{7500 \times 10^{-10}} = 4 \times 10^{14} \text{ Hz}.$

**Example: 6** Light of two different frequencies whose photons have energies 1 eV and 2.5 eV respectively, successively illuminates a metal of work function 0.5 eV. The ratio of maximum kinetic energy of the emitted electron will be  
 (a) 1 : 5                      (b) 1 : 4                      (c) 1 : 2                      (d) 1 : 1

**Solution :** (b) By using  $K_{\max} = E - W_0 \Rightarrow \frac{(K_{\max})_1}{(K_{\max})_2} = \frac{1 - 0.5}{2.5 - 0.5} = \frac{0.5}{2} = \frac{1}{4}$ .

**Example: 7** Photoelectric emission is observed from a metallic surface for frequencies  $\nu_1$  and  $\nu_2$  of the incident light rays ( $\nu_1 > \nu_2$ ). If the maximum values of kinetic energy of the photoelectrons emitted in the two cases are in the ratio of 1 : k, then the threshold frequency of the metallic surface is :

- (a)  $\frac{\nu_1 - \nu_2}{k - 1}$       (b)  $\frac{k\nu_1 - \nu_2}{k - 1}$       (c)  $\frac{k\nu_2 - \nu_1}{k - 1}$       (d)  $\frac{\nu_2 - \nu_1}{k - 1}$

**Solution :** (b) By using  $h\nu - h\nu_0 = k_{\max} \Rightarrow h(\nu_1 - \nu_0) = k_1$  and  $h(\nu_2 - \nu_0) = k_2$

Hence  $\frac{\nu_1 - \nu_0}{\nu_2 - \nu_0} = \frac{k_1}{k_2} = \frac{1}{k} \Rightarrow \nu_0 = \frac{k\nu_1 - \nu_2}{k - 1}$

**Example: 8** Light of frequency  $8 \times 10^{15} \text{ Hz}$  is incident on a substance of photoelectric work function 6.125 eV. The maximum kinetic energy of the emitted photoelectrons is :

- (a) 17 eV                      (b) 22 eV                      (c) 27 eV                      (d) 37 eV

**Solution :** (c) Energy of incident photon

$E = h\nu = 6.6 \times 10^{-34} \times 8 \times 10^{15} = 5.28 \times 10^{-18} \text{ J} = 33 \text{ eV}$ .

From  $E = W_0 + K_{\max} \Rightarrow K_{\max} = E - W_0 = 33 - 6.125 = 26.87 \text{ eV} \approx 27 \text{ eV}$ .

**Example: 9** A photo cell is receiving light from a source placed at a distance of 1 m. If the same source is to be placed at a distance of 2 m, then the ejected electron

- (a) Moves with one-fourth energy as that of the initial energy  
 (b) Moves with one fourth of momentum as that of the initial momentum  
 (c) Will be half in number  
 (d) Will be one-fourth in number

**Solution :** (d) **Number of photons**  $\propto$  **Intensity**  $\propto \frac{1}{(\text{distance})^2} \Rightarrow \frac{N_1}{N_2} = \left(\frac{d_2}{d_1}\right)^2 \Rightarrow$

$\frac{N_1}{N_2} = \left(\frac{2}{1}\right)^2 \Rightarrow N_2 = \frac{N_1}{4}$ .

**Example: 10** When yellow light incident on a surface no electrons are emitted while green light can emit. If red light is incident on the surface then

- (a) No electrons are emitted
- (b) Photons are emitted
- (c) Electrons of higher energy are emitted
- (d) Electrons of lower energy are emitted

**Solution :** (a)  $\lambda_{\text{Green}} < \lambda_{\text{Yellow}} < \lambda_{\text{Red}}$  . According to the question  $\lambda_{\text{Green}}$  is the maximum wavelength for which photoelectric emission takes place. Hence no emission takes place with red light.

**Example: 11** When a metal surface is illuminated by light of wavelengths 400 nm and 250 nm the maximum velocities of the photoelectrons ejected are  $v$  and  $2v$  respectively. The work function of the metal is ( $h =$  Planck's constant,  $c =$  velocity of light in air)

- (a)  $2hc \times 10^6 J$
- (b)  $1.5hc \times 10^6 J$
- (c)  $hc \times 10^6 J$
- (d)  $0.5hc \times 10^6 J$

**Solution :** (a) By using  $E = W_0 + K_{\text{max}} \Rightarrow \frac{hc}{\lambda} = W_0 + \frac{1}{2}mv^2$

$$\frac{hc}{400 \times 10^{-9}} = W_0 + \frac{1}{2}mv^2 \dots\dots(i) \text{ and } \frac{hc}{250 \times 10^{-9}} = W_0 + \frac{1}{2}m(2v)^2 \dots\dots(ii)$$

From equation (i) and (ii)  $W_0 = 2hc \times 10^6 J$ .

**Example: 12** The work functions of metals A and B are in the ratio 1 : 2. If light of frequencies  $f$  and  $2f$  are incident on the surfaces of A and B respectively, the ratio of the maximum kinetic energies of photoelectrons emitted is ( $f$  is greater than threshold frequency of A,  $2f$  is greater than threshold frequency of B)

- (a) 1 : 1
- (b) 1 : 2
- (c) 1 : 3
- (d) 1 : 4

**Solution :** (b) By using  $E = W_0 + K_{\text{max}} \Rightarrow E_A = hf = W_A + K_A$  and  $E_B = h(2f) = W_B + K_B$

So,  $\frac{1}{2} = \frac{W_A + K_A}{W_B + K_B} \dots\dots(i)$  also it is given that  $\frac{W_A}{W_B} = \frac{1}{2} \dots\dots(ii)$

From equation (i) and (ii) we get  $\frac{K_A}{K_B} = \frac{1}{2}$ .

**Example: 13** When a point source of monochromatic light is at a distance of 0.2m from a photoelectric cell, the cut-off voltage and the saturation current are 0.6 volt and 18 mA respectively. If the same source is placed 0.6 m away from the photoelectric cell, then

- (a) The stopping potential will be 0.2 V
- (b) The stopping potential will be 0.6 V



- (c) The saturation current will be 6 mA      (d) The saturation current will be 18 mA

**Solution :** (b) Photoelectric current ( $i$ )  $\propto$  Intensity  $\propto \frac{1}{(\text{distance})^2}$ . If distance becomes 0.6 m

(i.e. three times) so current becomes  $\frac{1}{9}$  times i.e. 2mA. Also stopping potential is independent of intensity i.e. it remains 0.6 V.

**Example: 14** In a photoemissive cell with exciting wavelength  $\lambda$ , the fastest electron has speed  $v$ . If the exciting wavelength is changed to  $3\lambda/4$ , the speed of the fastest emitted electron will be :

- (a)  $v(3/4)^{1/2}$  (b)  $v(4/3)^{1/2}$  (c) Less than  $v(4/3)^{1/2}$  (d) Greater than  $v(4/3)^{1/2}$

**Solution :** (d) From  $E = W_0 + \frac{1}{2}mv_{\max}^2 \Rightarrow v_{\max} = \sqrt{\frac{2E}{m} - \frac{2W_0}{m}}$  (where  $E = \frac{hc}{\lambda}$ )

If wavelength of incident light changes from  $\lambda$  to  $\frac{3\lambda}{4}$  (decreases)

Let energy of incident light changes from  $E$  to  $E'$  and speed of fastest electron changes from  $v$  to  $v'$  then  $v = \sqrt{\frac{2E}{m} - \frac{2W_0}{m}}$  .....(i) and

$$v' = \sqrt{\frac{2E'}{m} - \frac{2W_0}{m}} \quad \dots\dots(ii) \text{ As } E \propto \frac{1}{\lambda} \Rightarrow E' = \frac{4}{3}E \text{ hence } v' = \sqrt{\frac{2\left(\frac{4}{3}E\right)}{m} - \frac{2W_0}{m}}$$

$$\Rightarrow v' = \left(\frac{4}{3}\right)^{1/2} \sqrt{\frac{2E}{m} - \frac{2W_0}{m\left(\frac{4}{3}\right)^{1/2}}} \Rightarrow v' = \left(\frac{4}{3}\right)^{1/2} X = \sqrt{\frac{2E}{m} - \frac{2W_0}{m\left(\frac{4}{3}\right)^{1/2}}} > v \text{ SO } v' > \left(\frac{4}{3}\right)^{1/2} v.$$

**Example: 15** The minimum wavelength of X-rays produced in a Coolidge tube operated at potential difference of 40 kV is

- (a) 0.31 Å      (b) 3.1 Å      (c) 31 Å      (d) 311 Å

**Solution :** (a)  $\lambda_{\min} = \frac{12375}{40 \times 10^3} = 0.309 \text{ \AA} \approx 0.31 \text{ \AA}$

**Example: 16** The X-ray wavelength of  $L_\alpha$  line of platinum ( $Z = 78$ ) is 1.30 Å. The X-ray wavelength of  $L_\alpha$  line of Molybdenum ( $Z = 42$ ) is

- (a) 5.41 Å      (b) 4.20 Å      (c) 2.70 Å      (d) 1.35 Å

**Solution :** (a) The wave length of  $L_\alpha$  line is given by  $\frac{1}{\lambda} = R(z-7.4)^2 \left( \frac{1}{2^2} - \frac{1}{3^2} \right) \Rightarrow \lambda \propto \frac{1}{(z-7.4)^2}$

## Compton Effect Phenomenon

### ● Photons

Einstein presented his quantum theory of light and its elucidation of the photoelectric effect in a scientific paper that appeared in the spring of **1905**. He followed it, just a few weeks later, with a ground-breaking paper on the mathematics of Brownian motion. His special theory of relativity was published in the summer of that *annus mirabilis* and before the year's end he had also completed his doctoral thesis. In the space of just a few months, Einstein had set much of the agenda of physics for the next **so** years. *photon-whose* existence Einstein first conceived.

### ● Photon Mass

The **quantum** theory of light postulates that electromagnetic radiation propagates as particles-photons-that travel at the speed of light. According to this theory, the energy **possessed** by a photon depends only on the frequency,  **$f$** ; of the radiation with which it is associated :  $E_{photon} = hf$  (1)

According to the special theory of relativity, the **total** energy,  **$E$** , of any particle is given by :

$$E^2 = m_0^2 c^4 + c^2 p^2 \quad (2)$$

where  **$m_0$**  is the rest-mass of the particle,  **$p$**  is its linear momentum and  **$c$**  is the velocity of light. How can these two definitions of the particle's energy be reconciled in the *case* of the photon?

According to the principle of the constancy of the speed of light, no inertial observer **can** ever catch up with a photon in free space and move together with it such that it appears to be at rest; photons are never at rest. Consequently, the concept of the 'rest-mass of a photon' has no meaning; the rest-mass of a photon can be taken to be zero. Substituting the photon's zero rest-mass,  **$m_0 = 0$** , in equation (2) gives :

$$E_{photon}^2 = c^2 p_{photon}^2 \quad (3)$$

from which we **obtain**:  $p_{photon} = E_{photon} / c$  (4)

Thus, even though a photon has no rest-mass, a linear momentum,  **$P_{photon}$**  can be attributed to it. Substituting  **$E_{photon} = hf$**  and  **$c = f\lambda$** , in equation (3) gives

$$p_{\text{photon}} = \frac{hf}{c} = \frac{h}{\lambda} \dots\dots\dots(3)$$

where  $\lambda$  is the radiation's wavelength in *vacuo*. This simple relationship between the photon's linear momentum, **&,hoton**, and the wavelength,  $A$ , or frequency,  $fi$  of the radiation with which it is associated, is the fundamental link between the quantum theory of light and the wave theory of light. Although photons have no rest-mass, it is often useful to attribute a moving mass to them. Equating the relativistic expression for the total energy of a particle,  $E = mc^2$ , with that for the energy of a photon,  $E = hf$ , gives:

$$m_{\text{photon}} = \frac{hf}{c^2}$$

In his 1923 experiment, Compton provided the most conclusive confirmation of the particle aspect of radiation. By scattering X-rays off free electrons, he found that the wavelength of the scattered radiation is larger than the wavelength of the incident radiation. This can be explained only by assuming that the X-ray photons behave like particles.

At issue here is to study how X-rays scatter off free electrons. According to classical physics, the incident and scattered radiation should have the same wavelength. This can be viewed as follows. Classically, since the energy of the X-ray radiation is too high to be absorbed by a free electron, the incident X-ray would then provide an oscillatory electric field which sets the electron into oscillatory motion, hence making it radiate light with the same wavelength but with an intensity  $I$  that depends on the intensity of the incident radiation  $I_0$  (i.e.,  $I \propto I_0$ ). Neither of these two predictions of classical physics is compatible with experiment.

Compton succeeded in explaining his experimental results only after treating the incident radiation as a stream of particles—photons—colliding *elastically* with individual electrons. In this scattering process, which can be illustrated by the elastic scattering of a photon from a free electron (Figure ), the laws of elastic collisions can be invoked, notably the *conservation* of energy and momentum.

**The experimental findings** of Compton reveal that the wavelength of the scattered X-radiation *increases* by an amount  $\Delta\lambda$ , called the wavelength shift, and

that  $\Delta\lambda$  depends not on the intensity of the incident radiation, but only on the scattering angle.

**Quantum Explanation:** The explanation was given by Compton which was based on quantum theory of light. According to quantum theory when photon of energy  $h\nu$  strikes with the substance some of the energy of photon is transferred to the electrons, therefore the energy (or frequency) of photon reduces and wavelength increases.

Various assumptions were made for explaining the effect these were:

- (i) Compton Effect is the result of interaction of an individual particle and free electron of target.
- (ii) The collision is relativistic and elastic.
- (iii) The laws of conservation of energy and momentum hold good.

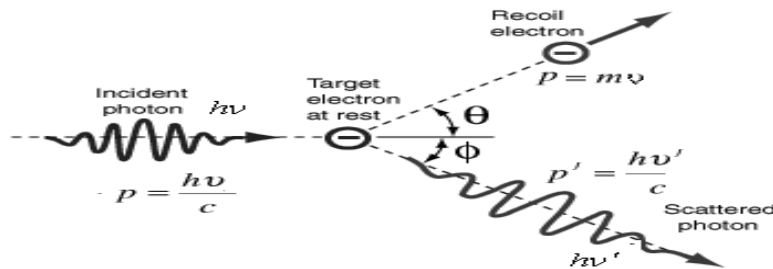

### Derivation of Compton Shift

Physical quantity	Before collision	After collision
The energy of incident photon	$= h\nu$	$= h\nu'$
The energy of electron	$= m_0c^2$	$= mc^2$
The momentum of the photon	$= \frac{h\nu}{c}$	$= \frac{h\nu'}{c}$
The momentum of electron	$= 0$	$= m\nu$

The energy of the system before collision  $= h\nu + m_0c^2$

The energy of the system after collision =  $h\nu' + mc^2$

According to the principle of conservation of energy

$$h\nu + m_0c^2 = h\nu' + mc^2 \quad \text{i.e. } mc^2 = h\nu - h\nu' + m_0c^2 \quad \dots\dots(1)$$

According to the principle of conservation of linear momentum along and perpendicular to the direction of incident photon (i.e., along x and y axis), we have

$$\frac{h\nu}{c} + 0 = \frac{h\nu'}{c} \cos\phi + mv \cos\theta$$

i.e.  $mvc \cos\theta = h\nu - h\nu' \cos\phi \quad \dots\dots(2)$  And

$$0 = \frac{h\nu'}{c} \sin\phi - mv \sin\theta \rightarrow \text{i.e. } mvc \sin\theta = h\nu' \sin\phi \quad \dots\dots(3)$$

Squaring (2) and (3) and then adding, we get

$$m^2v^2c^2 = (h\nu - h\nu' \cos\phi)^2 + (h\nu' \sin\phi)^2$$

Or  $m^2v^2c^2 = (h\nu)^2 + (h\nu')^2 \cos^2\phi - 2(h\nu)(h\nu') \cos\phi + (h\nu')^2 \sin^2\phi$

Or  $m^2v^2c^2 = (h\nu)^2 + (h\nu')^2 - 2(h\nu)(h\nu') \cos\phi \quad \dots\dots(4)$

Squaring equation (1), we get

$$m^2c^4 = m_0^2c^4 + (h\nu)^2 + (h\nu')^2 - 2(h\nu)(h\nu') + 2m_0c^2 [h\nu - h\nu'] \dots\dots(5)$$

Subtracting (4) from (5), we get

$$m^2c^4 - m^2v^2c^2 = m_0^2c^4 + 2(h\nu)(h\nu') [\cos\phi - 1] + 2m_0c^2 [h\nu - h\nu'] \dots\dots(6)$$

According to the theory of relativity :

$$m = \frac{m_0}{\sqrt{1 - \frac{v^2}{c^2}}}, m^2 = \frac{m_0^2}{\left(1 - \frac{v^2}{c^2}\right)}$$

$$\text{Or } m^2 \left( 1 - \frac{v^2}{c^2} \right) = m_o^2 \rightarrow m^2 c^2 - m^2 v^2 = m_o^2 c^2$$

Multiplying both sides by  $c^2$ , we get:  $m^2 c^4 - m^2 v^2 c^2 = m_o^2 c^4$  ....(7)

Using equation (7) equation (6) becomes :  $0 = 2(hv)(hv')[\cos \phi - 1] + 2m_o c^2 [hv - hv']$

$$\text{Or } 2(hv)(hv')[1 - \cos \phi] = 2m_o c^2 [hv - hv']$$

$$\frac{v - v'}{vv'} = \frac{h}{m_o c^2} (1 - \cos \phi) \rightarrow \frac{1}{v'} - \frac{1}{v} = \frac{h}{m_o c^2} (1 - \cos \phi) \dots\dots(8)$$

To find the relation in term of wavelength, let us substitute  $v' = c/\lambda'$  and  $v = c/\lambda$ , we thus have :  $\Delta \lambda = \lambda' - \lambda = \frac{h}{m_o c} (1 - \cos \phi)$

$$\text{Compton shift } \Delta \lambda = \frac{h}{m_o c} (1 - \cos \phi) \dots\dots(9)$$

**From above equations (8) and (9) following conclusions can be drawn**

1- The wavelength of the scattered photon  $\lambda' >$  that of the incident photon  $\lambda$ .

2-  $\Delta \lambda$  is independent of the incident wavelength.

3-  $\Delta \lambda$  have the same value for all substance containing free electron

4-  $\Delta \lambda$  only depend on the scattering angle  $\theta$ .

5-when  $\theta = 0$ ;  $\cos \theta = 1$   $\Delta \lambda = \lambda' - \lambda = 0$  &  $\lambda' = \lambda$ , the scattered wavelength is same as the incident wavelength in the direction of incidence.

$$6\text{-when } \theta=90; \cos \theta = 0: \Delta \lambda = \lambda' - \lambda = \frac{h}{m_o c} \rightarrow \Delta \lambda = \frac{h}{m_o c} = 0.02426 \text{ \AA} = \lambda_c \dots\dots(10)$$

Where  $\lambda_c$  is called the Compton wavelength of the electron.

$$\text{when } \theta=180^\circ; \cos \theta = -1 \quad \rightarrow \quad \Delta\lambda_{\max} = \frac{2h}{m_0c} = 0.04652 \text{ \AA} \dots\dots(11)$$

### Why Compton Effect is not observed in visible spectrum

The maximum change in wavelength  $\lambda_{\max}$  is  $0.04652 \text{ \AA}$  or roughly  $0.05 \text{ \AA}$ . This small therefore can not be observed for wavelength longer than few angstrom units. For example-

Incident adiation	Incident avelength	$\Delta\lambda_{\max}$	incident radiation %
X-ray	$1 \text{ \AA}$	$0.05 \text{ \AA}$	5% (detectable)
Visible	$5000 \text{ \AA}$	$0.05 \text{ \AA}$	0.001% (undetectable)

### ●Direction of Recoil electron

Dividing equation (5) by (4) direction of recoil electron is given by

$$\tan \theta = \frac{h\nu' \sin \phi}{h\nu - h\nu' \cos \phi} \quad \rightarrow \quad \tan \theta = \frac{c/\lambda \sin \phi}{c/\lambda - c/\lambda' \cos \phi} \quad \rightarrow \quad \tan \theta = \frac{\lambda \sin \phi}{\lambda - \lambda' \cos \phi} \dots\dots(12)$$

### ●Kinetic Energy of Recoil Electron

The kinetic energy gained by electron is equal to the energy loss by the scattered

$$\text{photon } (m - m_0)c^2 = h\nu - h\nu' \rightarrow (m - m_0)c^2 = hc \left( \frac{\lambda - \lambda'}{\lambda\lambda'} \right)$$

$$E = hc \left( \frac{\lambda - \lambda'}{\lambda\lambda'} \right) \quad \text{Where } \lambda' = \lambda + \frac{h}{m_0c}(1 - \cos \phi) \dots\dots(13)$$

●**Verification of Compton Effect:** A beam of monochromatic X-ray of known wavelength  $\lambda$  is made incident on a graphite scatterer. These were observed at different angles with a Bragg spectrometer.

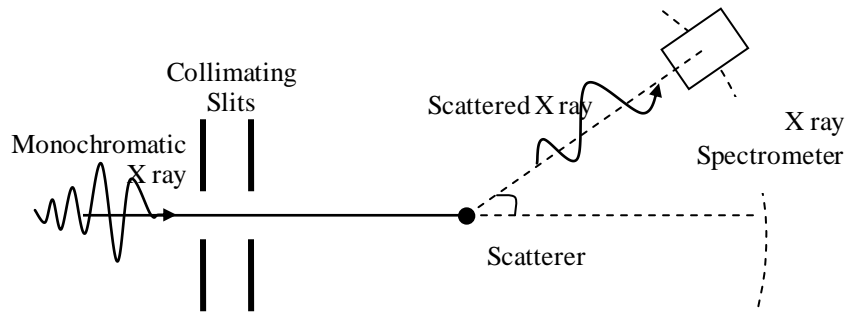

**Figure: Experimental verification of Compton Effect**

The intensity distribution versus wavelength for various angles is plotted as shown in figure. It is obvious that the curves have two peaks, one corresponding to modified radiations and the other to unmodified radiations. The difference between the two peaks on the wavelength axis gives the Compton shift ( $\Delta\lambda$ ). The curve shows the greater is the scattering angle; greater is the Compton shift in accordance with :  $\Delta\lambda = \lambda' - \lambda = \frac{h}{m_0c}(1 - \cos \phi)$  At  $\phi = 90^\circ$ ,  $\Delta\lambda = 0.02426\text{\AA}$

Thus Compton Effect is experimentally verified.

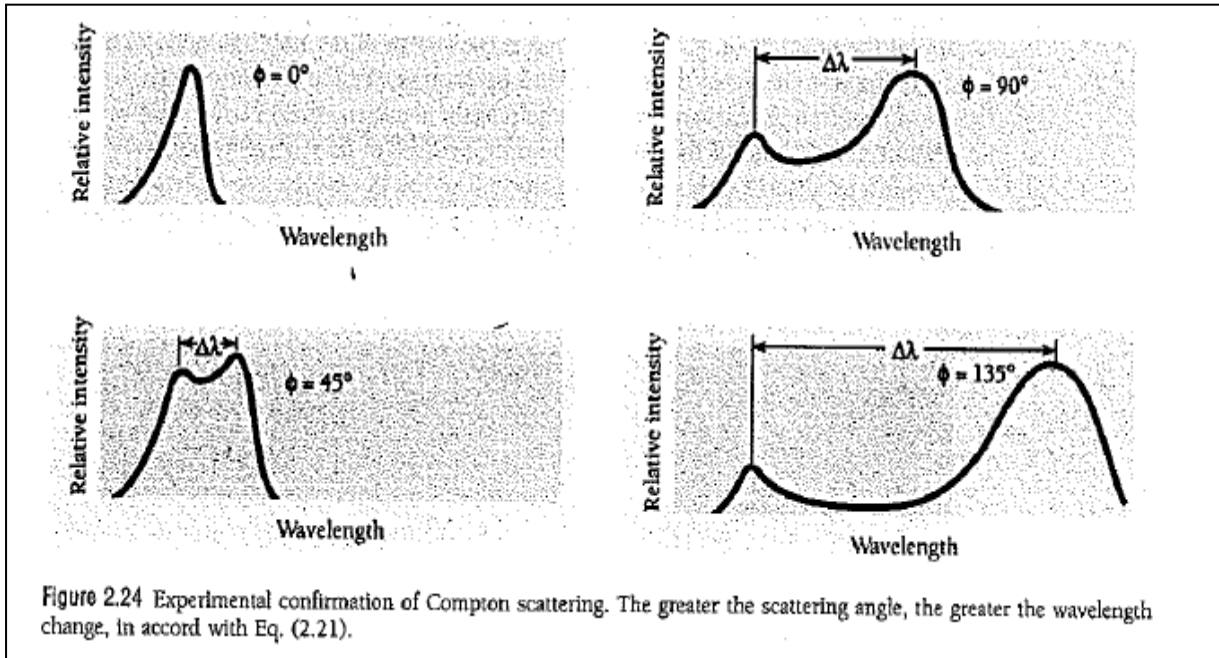



## X-Ray Phenomenon

The photoelectric effect provides convincing evidence that photons of light can transfer energy to electrons. Is the inverse process also possible? That is, can part or all of the kinetic energy of a moving electron be converted into a photon? As it happens, the inverse photoelectric effect not only does occur but had been discovered (though not understood) before the work of Planck and Einstein.

In 1895, by chance, experimenting with cathode rays (doing similar things to J.J Thomson). X-rays was discovered by **scientist Rontgen** that's why they are also called Rontgen rays. He discovered that when pressure inside a discharge tube kept  $10^{-3}$  mm of Hg and potential difference is 25 kV . While experimenting in the dark ,there was a sheet of paper covered with a phosphor sitting around at the other end of the laboratory, Rontgen noticed that phosphor lights up when he switches on his cathode ray tube. **He found that a highly penetrating radiation of unknown nature is produced when fast electrons impinge on matter.**

Not long after this discovery it became clear that, **X-rays** are electromagnetic waves of very short wavelengths in the range of 0.01 to 10 nanometers corresponding to frequencies in the range 30 Peta-hertz ( $10^{15}$  Hz) to 30 Exa-hertz ( $10^{18}$  Hz) and because of their high frequency, their energy are also high and its energies varies in the range (100 eV to 100 keV) .

### **Braking radiation: The source of X-rays in the Crookes tube:**

Braking radiation (*Bremsstrahlung* in German) is wide-spectrum electromagnetic radiation created by the deceleration of electric charges.

When a target is bombarded with a beam of electrons, the electric field of the nuclei in the target cause the electrons to brake and be deflected. According to Maxwell-Lorentz equations, electric charges whose velocity varies, whether in magnitude or direction, will emit electromagnetic radiation.

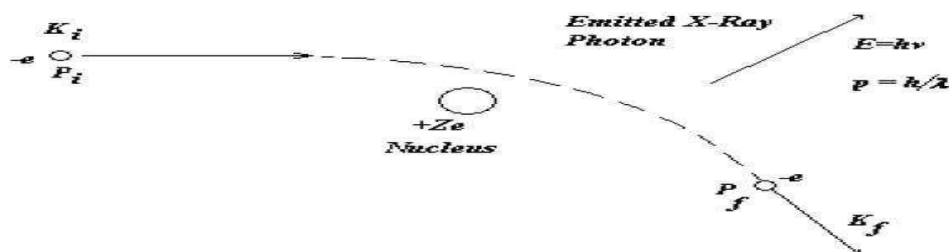

Figure 1: Braking radiation. The electrons moving close to the (positive) nuclei in the atoms in the target are deflected. They lose energy and, for each electron, the energy difference corresponds to that of the emitted photon.

As the deceleration is unquantified, the braking radiation is a flow of photons with a continuous energy spectrum. The energy emitted as X photons is taken from the kinetic energy  $E_c$  of the e-charged electron, which continues its trajectory with a lower kinetic energy  $E'_c$  such as:

$$E_c - E'_c = E = h\nu$$

If the electron was accelerated with a difference in potential  $U$  and all the energy of the incident electron was transformed into radiation, this would give max. min  $h\nu_{\max} = eU$  and, for the minimum wavelength of the spectrum:  $h c / \lambda_{\min} = eU$

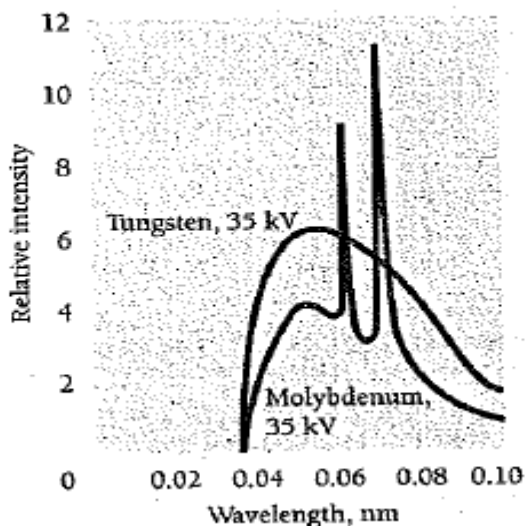

Figure X-ray spectra of tungsten and molybdenum at 35 kV accelerating potential.

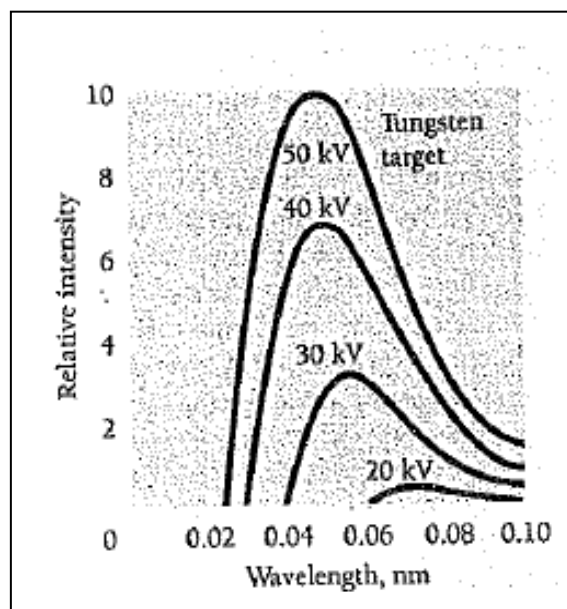

Figure X-ray spectra of tungsten at various accelerating potentials

*Note: The right figure described the spectra obtained by bombarding tungsten with electrons whose energy varied between 20 and 50 kV. The graph shows that the greater  $V$  is, the shorter the wavelength becomes ( $V = 20\text{kV}$ ,  $\lambda_{\text{min}} = 0,6\text{\AA}$ ;  $U = 40\text{ kV}$ ,  $\lambda_{\text{min}} = 0,3\text{\AA}$ ). The graph also shows that most of the spectrum corresponds to a wavelength of between  $0.3$  and  $1\text{\AA}$ , and therefore to a frequency  $C/\lambda$  of between  $3.1018\text{ Hz}$  and  $1019\text{ Hz}$ , in the X-ray range.*

Energy loss due to bremsstrahlung is more important for electrons than for heavier particles because electrons are more violently accelerated when passing near nuclei in their paths. The greater the energy of an electron and the greater the atomic number of the nuclei it encounters, the more energetic the bremsstrahlung

### (1) Production of X-rays

There are three essential requirements for the production of X-rays

- (i) A source of electron
- (ii) An arrangement to accelerate the electrons
- (iii) A target of suitable material of high atomic weight and high melting point on which these high speed electrons strike.

### (2) Coolidge X-ray tube

It consists of a highly evacuated glass tube containing cathode and target. The cathode consist of a tungsten filament. The filament is coated with oxides of barium or strontium to have an emission of electrons even at low temperature. The filament is surrounded by a molybdenum cylinder kept at negative potential *w.r.t.* the target.

It was found that a target will be better and produces X rays if it has the following :

1. has high atomic number
2. high melting point.
3. high conductivity towards heat and electricity.
4. low vapour pressure at high temperature.

The face of the target is set at  $45^\circ$  to the incident electron stream, it is made from Tantalum, platinum, tungsten or molybdenum

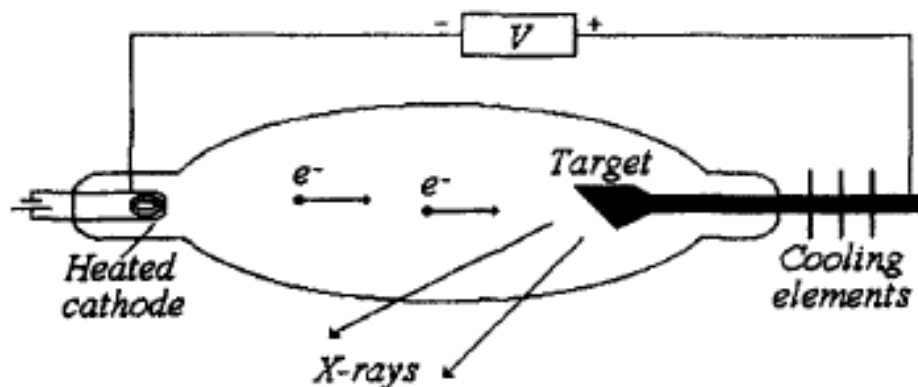

The filament is heated by passing the current through it. A high potential difference ( $\approx 10\text{ kV}$  to  $80\text{ kV}$ ) is applied between the target and cathode to accelerate the electrons which are emitted by filament. The stream of highly energetic electrons are focused on the target.

Most of the energy of the electrons is converted into heat (above 98%) and only a small fraction of the energy of the electrons (about 2%) is used to produce X-rays.

During the operation of the tube, a huge quantity of heat is produced in this target, this heat is conducted through the copper anode to the cooling fins from where it is dissipated by radiation and convection.

Electric current through the filament heats the cathode, and the electrons in the cathode gain enough kinetic energy to overcome their binding to the cathode surface and be released (this is called thermionic emission). The electrons are then accelerated across the evacuated tube by a large electrostatic potential difference  $V$ , typically several thousand volts, and strike the target, which is the anode. The kinetic energy,  $E_k$ , acquired by the electrons just before striking the target is given by :

$$E_k = eV \quad (1)$$

Upon striking the target the electrons are decelerated and brought essentially to rest in collisions. Each electron loses its kinetic energy,  $eV$ , because of its impact with the target. Most of this energy appears as thermal energy in the target. (For this reason x-ray targets are usually water-cooled.) In addition, however, there is the production of electromagnetic radiation (x-rays) through the bremsstrahlung process. Bremsstrahlung (German for braking radiation) is the name given to the

x-rays produced when a charged particle is accelerated. When an electron strikes the target it will experience deflections of its path due to near collisions with the nuclei of the target atoms. These deflections (accelerations) are accompanied by the emission of one or more bremsstrahlung photons (x-rays). From conservation of energy, the electron loses an amount of kinetic energy in the bremsstrahlung process equal to the energy ( $h\nu$ ) of the photon or photons created. Any electron striking the target may make a number of bremsstrahlung collisions with atoms in the target thereby producing a number of photons. The most energetic photon is produced by an electron whose entire kinetic energy is converted into the electromagnetic energy of a single x-ray photon when the electron is brought to rest in a single collision.

$$\therefore E_K = h\nu_{\max} \tag{2}$$

$$eV = h\nu_{\max} \tag{3}$$

or in terms of wavelength,

$$eV = hc/\lambda_{\min} \tag{4}$$

Thus, the energy distribution of x-ray photons produced in an x-ray tube operated at a given voltage  $V$  is continuous, with a well-defined maximum frequency  $\nu_{\max}$  or minimum wavelength  $\lambda_{\min}$ . Superimposed on the typical continuous x-ray spectrum, with its minimum wavelength dependent on the tube voltage  $V$ , are sharp spikes dependent on the target material.

**(2) Properties of X-rays**

1. X-rays are not deflected by electric and magnetic field, as they have no charge.
2. They are highly penetrating and can pass through many solids
3. They cause fluorescence in many substances *i.e.* barium, plato-cyanide, cadmium, tungsten, zinc sulphide etc.
4. They affect a photographic plate.
5. They ionize a gas and also knock out electrons from certain metals on which they fall. This effect is known as photoelectric effect.
6. They travel in straight line with velocity of light.

- 7. X-rays show reflection, refraction interference, diffraction and polarization in a similar way as light.
- 8. Today X ray Laser are also made and being used.
- 9. *Scattered X-rays*: They are practically of same nature and wavelength as the primary X-rays. Their properties do not depend upon the nature of the scattering substance.
- 10. Long exposure to X-rays is injurious for human body.
- 11. Lead is the best absorber of X-rays.
- 12. For X-ray photography of human body parts,  $BaSO_4$  is the best absorber.
- 13. They produce photoelectric effect and Compton effect
- 14. X-rays are not emitted by hydrogen atom.
- 15-These cannot be used in Radar because they are not reflected by the target.

**(3): Quality of X-rays Spectra.**

Quality of X-rays implies the penetrating power of X-rays, which can be controlled by varying the potential difference between the cathode and the target.

For large potential difference, energy of bombarding electrons will be large and hence larger is the penetration power of X-rays.

**Depending upon the penetration power, X-rays are of two types :**

Hard X-rays	Soft X-rays
More penetration power	Less penetration power
More frequency of the order of $\approx 10^{19}$ Hz	Less frequency of the order of $\approx 10^{16}$ Hz
Lesser wavelength range (0.1Å – 4Å)	More wavelength range (4Å – 100Å)

**(i):Control of intensity of X-rays :** Intensity implies the number of X-ray photons produced from the target. The intensity of X-rays emitted is directly proportional to the electrons emitted per second from the filament and this can be increased by increasing the filament current. So *intensity of X-rays*  $\propto$  *Filament current*

**Note : Wavelength of continuous X-ray photon ranges from certain minimum ( $\lambda_{min}$ ) to infinity.**

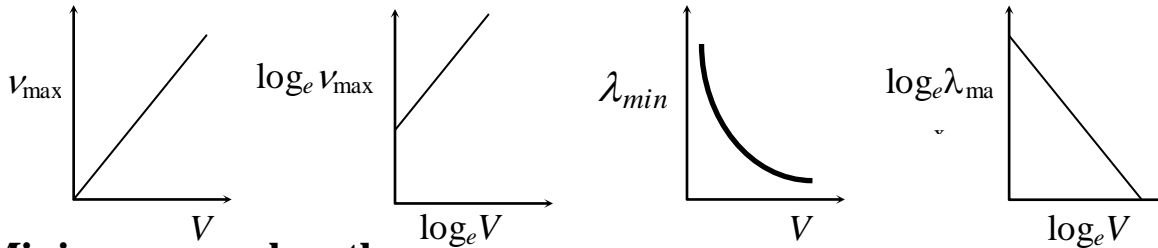

**Minimum wavelength**

When the electron loses whole of it's energy in a single collision with the atom, an X-ray photon of maximum energy  $h\nu_{max}$  is emitted i.e.

$$\frac{1}{2}mv^2 = eV = h\nu_{max} = \frac{hc}{\lambda_{min}}$$

Where;

- $v$  = velocity of electron before collision with target atom,
- $V$  = potential difference through which electron is accelerated,
- $c$  = speed of light =  $3 \times 10^8$  m/s ,

$\nu_{max}$  = Maximum frequency of radiations (X-rays)  $\nu_{max} = \frac{eV}{h}$

$\lambda_{min}$  = Minimum wave length = cut off wavelength of X-ray

$$\lambda_{min} = \frac{hc}{eV} = \frac{12375}{V} \text{ \AA}$$

**(4): X-rays Spectra.**

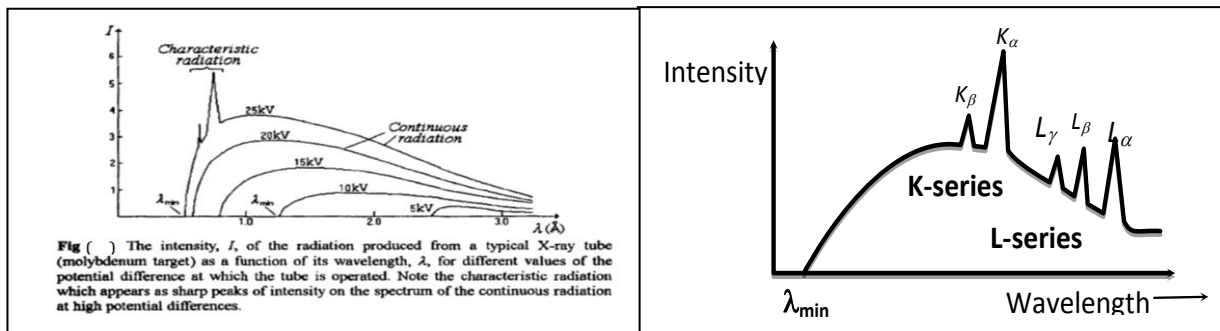

Fig ( ) The intensity,  $I$ , of the radiation produced from a typical X-ray tube (molybdenum target) as a function of its wavelength,  $\lambda$ , for different values of the potential difference at which the tube is operated. Note the characteristic radiation which appears as sharp peaks of intensity on the spectrum of the continuous radiation at high potential differences.

In X-ray tube, when high speed electrons strikes the target, they penetrate the target. They loses their kinetic energy and comes to rest inside the metal. The

electron before finally being stopped makes several collisions with the atoms in the target. At each collision one of the following two types of X-rays may get form.

**Typical** intensity spectra of **the** X-ray radiation produced at various potential differences by such devices are shown in Fig 2.20. All the spectra exhibit a **sharp cut-off at** a specific wavelength below which radiation is not produced. **This** minimum wavelength, **& in,** is inversely proportional to the potential difference, **V,** at which the device is operated. At low and **medium** potential differences, **5kV** to **20kV,** the **spectrum** above the cut-off is continuous. Changing the material from which the target in the **tube** is made has no effect on the spectrum of this continuous radiation. At high potential differences, **>20kV,** sharp intensity **peaks** appear in the spectrum at wavelengths that are a characteristic of the material from which the anode target is made

**(5) : ORIGIN OF X-RAYS**

At certain sharply defined wavelengths, the intensity of X-rays is very large as marked  $K_{\alpha}, K_{\beta}$ ..... As shown in figure. These X-rays are known as

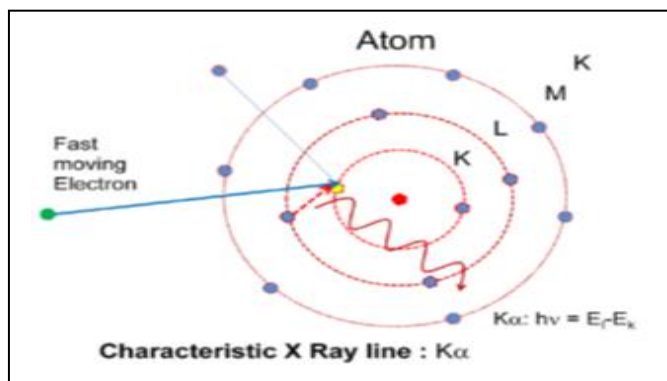

**charctersitic or line X-rays spectra.** At other wavelengths the intensity varies gradually and these X-rays are **called continuous X-rays.**

It is noticed that the spectrum of X-rays is different if the target element/metal is different.. *The sharp line in the spectrum was related to the material of the target and its atomic number. Also the sharp lines suggest that the X-rays are originated from the jumping of an electron from one orbit to another as it is a case of many emission spectrum. While the continuous spectrum is explained through phenomenon of Bremsstrahlung (Braking radiation).*



When a high speed electron from the cathode strike the target, then the electron eject one electron from its lower orbits (K, L or M). To fill the space created by leaving electron from lower orbit (K, L or M) the electron comes from higher orbit (L or M) to lower orbit which in turn radiates extra energy of fixed quanta in the form of X-rays photons  $h\nu = E_1 - E_2$

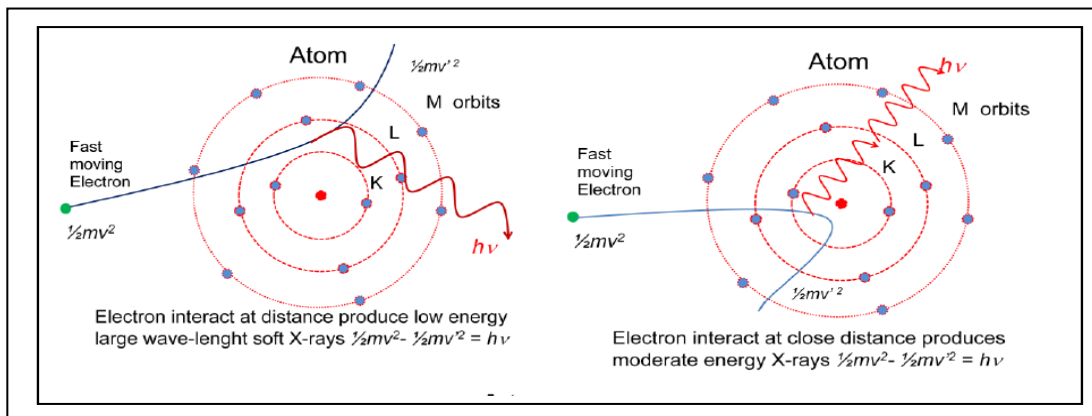

To explain continuous spectrum of X-rays it is referred to as "Bremsstrahlung", which means braking radiation in general. In this process, the high energy electron passes through the atom, it is attracted by the positive charge of the nucleus and is deflected in its path. During the deflection of the fast moving electron in the strong electric field of the nucleus, the Electron loses its velocity and energy in form of Electromagnetic radiation of high frequency and the energy  $h\nu$  is emitted. By the law of conservation of energy  $\frac{1}{2}mv^2 - \frac{1}{2}mv'^2 = h\nu$

The highest frequency that is possible is the one in which the electron is completely stopped ( $v'=0$ ) by the atom. The electron makes an impact with the nucleus of the atom. In this special case,  $\frac{1}{2}mv^2 = h\nu_{max}$ . The kinetic energy of the electrons in the beam striking the target is given by the voltage  $V$  applied to the tube, we may use equation:

$$eV = h\nu_{max}$$

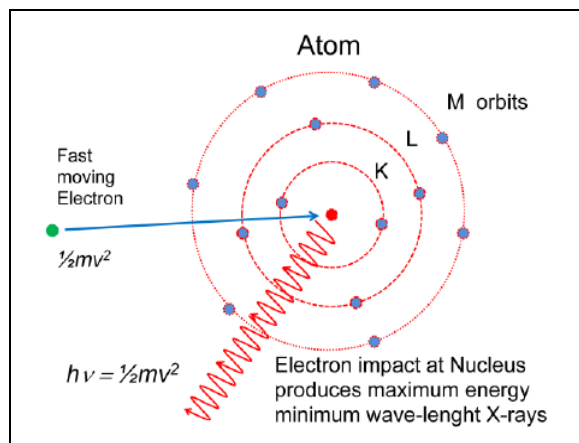

The spectrum has a sharp cutoff at low wavelength, which is due to the limited energy of the incoming electrons. For example, if an electron in the tube is

accelerated through 60 kV, then it will acquire a kinetic energy of 60 keV, and when it strikes the target it can create X-rays with energy of at most 60 keV. A photon with energy of at most 60 keV has minimum wavelength of 21 pm, so the continuous X-ray spectrum has exactly that cutoff, as seen in the graph. More generally the formula for the low-wavelength cutoff is :  $\lambda_{\min}$  ( in nm) :  $hc/eV \sim 1.24/V$  (in KV) where  $h$  is Planck's constant,  $c$  is the speed of light,  $V$  is the voltage that the electrons are accelerated through and  $e$  is the elementary charge,  $pm$  is picometres. This is called the Duane–Hunt law.

As explained above in the origin of X-rays, the X-ray spectrum consists of (a) continuous spectrum and (b) line spectrum

### (a) Continuous Spectrum

As an electron passes close to the positive nucleus of atom, the electron is deflected from it's path as shown in the left figure. This results in deceleration of electron. The loss in energy of the electron during deceleration is emitted in the form of X-rays. The X-ray photons emitted so form the continuous X-ray spectrum as in right figure. It has a sharply defined

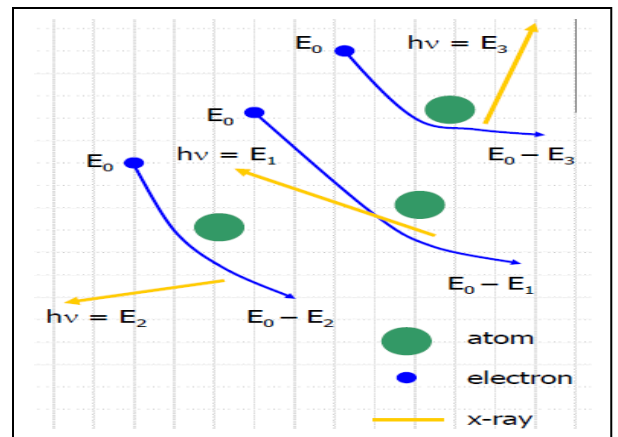

short wavelength limit given by :  $\lambda_{\min} = 1240/V \text{ \AA}$

The cut-off wavelength  $\lambda_{\min}$  is independent of the nature of the target material but is inversely proportional to the potential difference between the cathode and anode of an X-ray tube. The value of  $\lambda_{\min}$  decreases as this potential difference is increased. The intensity of the continuous spectrum is found very nearly proportional to the square of the applied voltage for a given target and the atomic number of the target material when a constant potential difference is applied. There is a shift of maximum intensity position towards the short wavelength side as voltage is increased.

### Properties of the Continuous Spectrum

- Smooth, monotonic function of intensity vs wavelength.

- The intensity is zero up to a certain wavelength – short wavelength limit (SWL). The electrons transfer all their energy into photon energy:

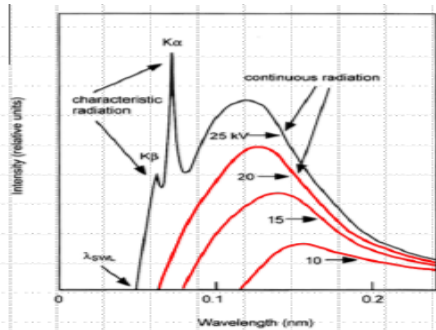

$$eV = h\nu_{\max}$$

$$\lambda_{SWL} = \frac{c}{\nu_{\max}} = \frac{hc}{eV}$$

$$\lambda_{SWL} = \frac{12.398 \times 10^3}{V}$$

$\lambda$ - in  $\text{\AA}$   
 $V$ - in volts

- The total x-ray energy emitted per second depends on the atomic number  $Z$  of the target material and on the x-ray tube current. This total x-ray intensity is given by :

$$I_{\text{cont}} = A i Z V^m$$

where,

$A = \text{proportionality constant}$  &  $i = \text{tube current}$  (measure of the number of electrons per second striking the target) & and  $m = \text{constant equal } 2$

- Continuous X-rays are produced due to the phenomenon called "Bremsstrahlung". It means slowing down or braking radiation

**(b) charctersitic or Line Spectrum**

Few of the fast moving electrons having high velocity penetrate the surface atoms of the target material and knock out the tightly bound electrons even from the inner most shells of the atom.

When the electron is knocked out, a vacancy is created at that place. To fill this vacancy electrons from higher shells jump to fill the created vacancies, we know that when an electron jumps from a higher energy orbit  $E_1$  to lower energy orbit  $E_2$ , it radiates energy  $(E_1 - E_2)$ . Thus this energy difference is radiated in the form of X-rays of very small but definite wavelength which depends upon the target material. The X-ray spectrum consist of sharp line is **called line or characteristic X-ray spectrum.**

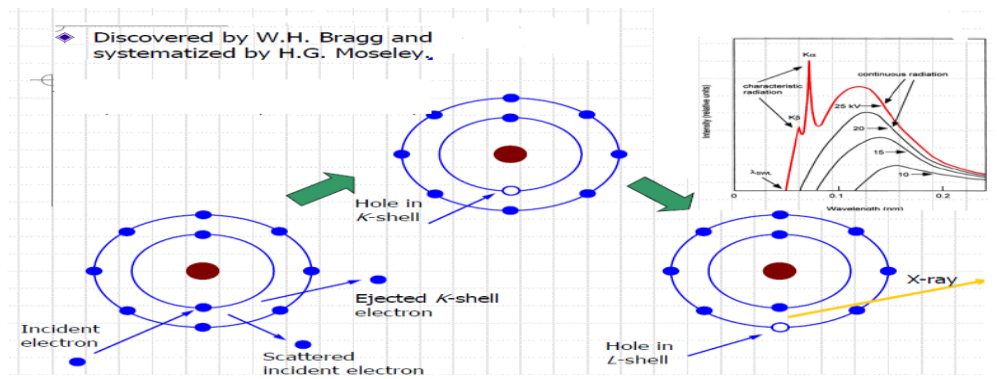

***K, L, M, ..... series***

If the electron striking the target eject an electron from the *K*-shell of the atom, a vacancy is crated in the *K*-shell. Immediately an electron from one of the outer shell, say *L*-shell jumps to the *K*-shell emitting an X-ray photon of energy equal to the energy difference between the two shells. Similarly if an electron from the *M*-shell jumps to the *K*-shell, X- ray photon of higher energy is emitted. The X-ray photons emitted due to the jump of electron from th to the *K*-shells gives  $K_{\alpha}$ ,  $K_{\beta}$ ,  $K_{\gamma}$  lines of the *K*-series of the spectrum.

Similarly, if the electron striking the target ejects an electron from the *L*-shell of the target atom, an electron from the *M*, *N* .. shells jumps to the *L*-shell so that X-rays photons of lesser energy are emitted. These photons form the lesser energy emission. These photons form the *L*-series of the spectrum. In a similar way the formation of *M* series, *N* series etc. may be explained .

*K*-series being most energetic constitute the hard X-rays whereas *L* series and *M* series form the soft X-rays. Line spectrum is the characteristics of the target material used. The number of lines present in the spectrum depends both on the nature of the target material and the excitation voltage.

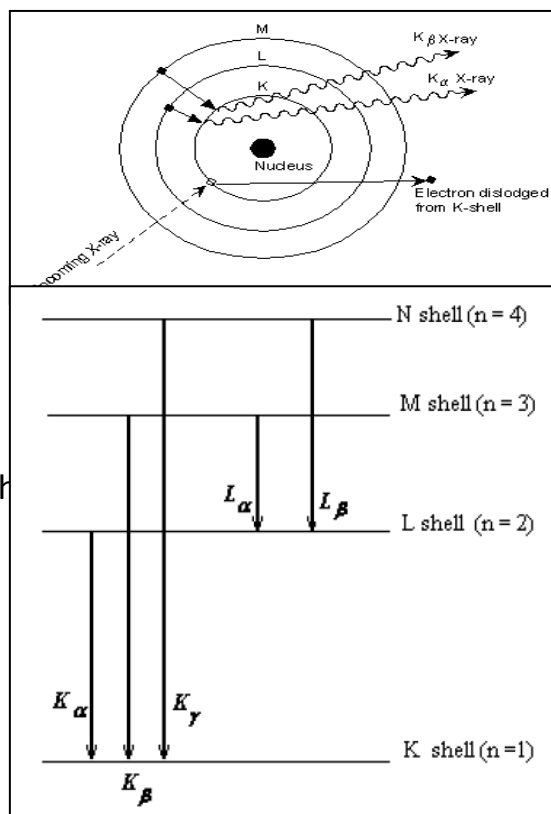

There is a regular shift towards shorter wavelength in the K spectrum as the atomic number of the target is increased. The exact relationship, as found by Moseley, is given as :

$$\nu_2 / \nu_1 = (Z_2 + 1)^2 / (Z_1 + 1)^2$$

where  $\nu_1$  = frequency of  $K_\alpha$  line for a target material having atomic number  $Z_1$  and  $\nu_2$  and  $Z_2$  are similar quantities for some different target material.

**Energy and wavelength of different lines**

Series	Transition	Energy	Wavelength
$K_\alpha$	$L_{(2)} \rightarrow K_{(1)}$	$E_L - E_K = h\nu_{K\alpha}$	$\lambda_{K\alpha} = \frac{hc}{E_L - E_K} = \frac{12375}{(E_L - E_K)eV} \text{ \AA}$
$K_\beta$	$M_{(3)} \rightarrow K_{(1)}$	$E_M - E_K = h\nu_{K\beta}$	$\lambda_{K\beta} = \frac{hc}{E_M - E_K} = \frac{12375}{(E_M - E_K)eV} \text{ \AA}$
$L_\alpha$	$M_{(3)} \rightarrow L_{(2)}$	$E_M - E_L = h\nu_{L\alpha}$	$\lambda_{L\alpha} = \frac{hc}{E_M - E_L} = \frac{12375}{(E_M - E_L)eV} \text{ \AA}$

**Note :** The wavelength of the line spectra of doesn't depend on accelerating voltage. It depends on the atomic number (Z) of the target material.

- $\lambda_{K\alpha} < \lambda_{L\alpha} < \lambda_{M\alpha}$  and  $\nu_{K\alpha} > \nu_{L\alpha} > \nu_{M\alpha}$
- $\lambda_{K\alpha} > \lambda_{L\beta} < \lambda_{K\gamma}$

**Properties of the Line Spectrum**

- Usually only the K-lines are useful in x-ray diffraction.
- There are several lines in the K-set. The strongest are  $K_{\alpha 1}$  ,  $K_{\alpha 2}$  ,  $K_{\beta 1}$  .
- $\alpha_1$  and  $\alpha_2$  components are not always resolved –Kadoublet.  $K_{\alpha 1}$  is always about twice as strong as  $K_{\alpha 2}$  , while ratio of  $K_{\alpha 1}$  to  $K_{\beta 1}$  averages about 5/1.
- The intensity of any characteristic line depends both on the tube current  $i$  and the amount by which the applied voltage  $V$  exceeds the critical excitation voltage for that line. For a K-line:

$$I_{K\text{-line}} = Bi(V - V_K)^n$$

B – proportionality constant  
 $V_K$  – the K excitation voltage  
 $n \approx 1.5$

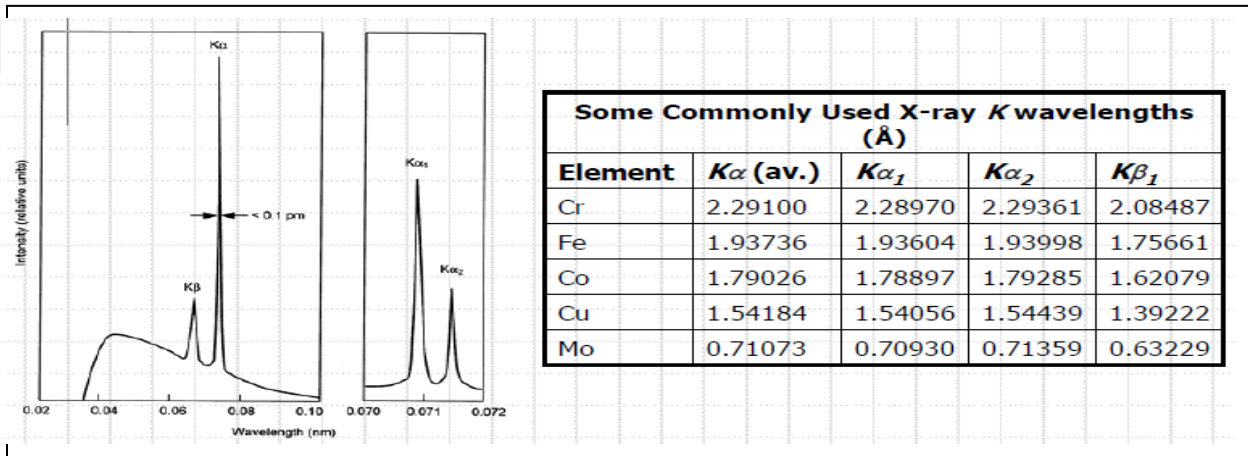

- Characteristic lines are also very narrow, most of them less than 0.001 Å wide (Full Width At Half Maximum).
- High intensity and narrow K-lines makes x-ray diffraction possible, since it generally requires the use of monochromatic radiation

**(4) Absorption of X-rays**

X-rays are absorbed when they incident on substance. Intensity of emergent X-rays

$I = I_0 e^{-\mu x}$  So intensity of absorbed X-rays

$I' = I_0 - I = I_0 (1 - e^{-\mu x})$

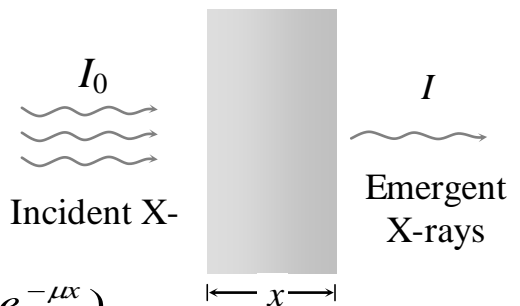

where  $x$  = thickness of absorbing medium,  $\mu$  = absorption coefficient

**Note** : The thickness of medium at which intensity of emergent

X-rays becomes half *i.e.*  $I = \frac{I_0}{2}$  is called half value thickness ( $x_{1/2}$ ) and it is given

as  $x_{1/2} = \frac{0.693}{\mu}$ .

**Mosley'Law**

Studied the characteristic X-ray spectrum of a number of a heavy elements and concluded that the spectra of different elements that are very similar and

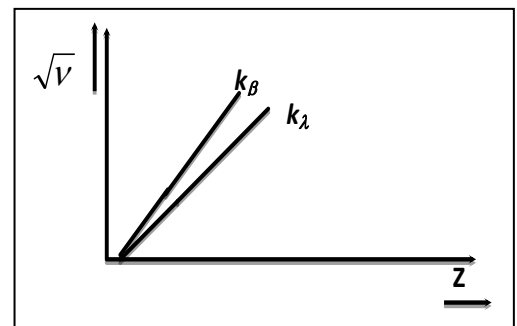

with increasing atomic number, the spectral lines merely shift towards higher frequencies. He also gave the following relation  $\sqrt{\nu} = a(Z - b)$

where;  $\nu$  = Frequency of emitted line,  $Z$  = Atomic number of target,  $a$  = Proportionality constant,  $b$  = Screening constant.

**Notes :**

•  $a$  and  $b$  doesn't depend on the nature of target. Different values of  $b$  are as follows

$$b = 1 \quad \text{for } K\text{-series}$$

$$b = 7.4 \quad \text{for } L\text{-series}$$

$$b = 19.2 \quad \text{for } M\text{-series}$$

•  $(Z - b)$  is called effective atomic number.

**More about Mosley's law**

(i) It supported Bohr's theory

(ii) It experimentally determined the atomic number ( $Z$ ) of elements.

(iii) This law established the importance of ordering of elements in periodic table by atomic number and not by atomic weight.

(iv) Gaps in Moseley's data for  $A = 43, 61, 72, 75$  suggested existence of new elements which were later discovered.

(v) The atomic numbers of  $Cu, Ag$  and  $Pt$  were established to be 29, 47 and 78 respectively.

(vi) When a vacancy occurs in the  $K$ -shell, there is still one electron remaining in the  $K$ -shell. An electron in the  $L$ -shell will feel an effective charge of  $(Z - 1)e$  due to  $+Ze$  from the nucleus and  $-e$  from the remaining  $K$ -shell electron, because  $L$ -shell orbit is well outside the  $K$ -shell orbit.

(vii) Wave length of characteristic spectrum  $\frac{1}{\lambda} = R(Z - b)^2 \left( \frac{1}{n_1^2} - \frac{1}{n_2^2} \right)$  and energy of

X-ray radiations.  $\Delta E = h\nu = \frac{hc}{\lambda} = Rhc(Z - b)^2 \left( \frac{1}{n_1^2} - \frac{1}{n_2^2} \right)$

(viii) If transition takes place from  $n_2 = 2$  to  $n_1 = 1$  ( $K_\alpha$  - line)

(a)  $a = \sqrt{\frac{3RC}{4}} = 2.47 \times 10^{15} \text{ Hz}$

(b)  $\nu_{K\alpha} = RC(Z - 1)^2 \left( 1 - \frac{1}{2^2} \right) = \frac{3RC}{4} (Z - 1)^2 = 2.47 \times 10^{15} (Z - 1)^2 \text{ Hz}$

(c) In general the wavelength of all the  $K$ -lines are given by  $\frac{1}{\lambda_K} = R(Z-1)^2 \left(1 - \frac{1}{n^2}\right)$  where  $n = 2, 3, 4, \dots$

$$\text{While for } K_\alpha \text{ line } \lambda_{K\alpha} = \frac{1216}{(Z-1)} \text{ \AA}$$

(d)  $E_{K\alpha} = 10.2(Z-1)^2 eV$

### •Diffraction of X-rays

In 1912 a method was devised for measuring the wavelengths of x-rays. A diffraction experiment had been recognized as ideal, but as we recall from physical optics, the spacing between adjacent lines on a diffraction grating must be of the same order of magnitude as the wavelength of the light for satisfactory results, and gratings cannot be ruled with the minute spacing required by x-rays.

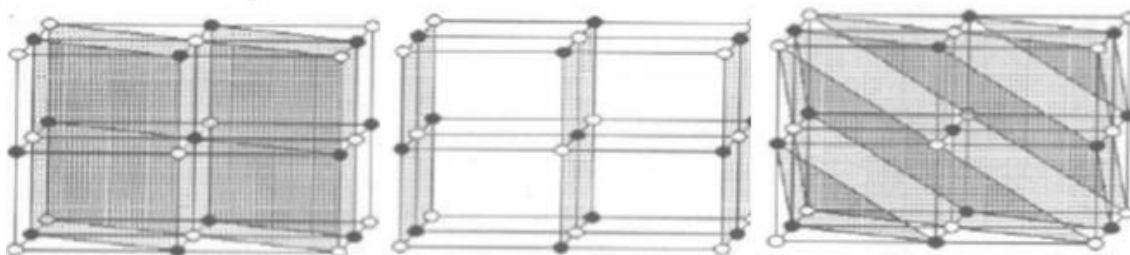

Fig ( ): 'Families' of parallel planes in the same crystal. In each family the distance between the planes is different.

The first X-ray diffraction experiments were carried out by M. von Laue. Using the continuous X-ray spectrum and the geometry shown in Fig. 2, he obtained a picture containing a pattern of spots, each of which corresponds to coherent reflection of the X-ray beam from one set of the crystal planes. This experiment is a striking demonstration of the wave nature of X-rays.

- *Single Crystal (Laue) Diffraction* – a beam of X-rays of all wavelengths is directed at a single crystal, which sits stationary in front of a photographic plate. **A series of diffraction spots surround the central point of the beam, corresponding to diffraction from a given series of atomic planes (at right).**

Max von Laue realized that the wavelengths suggested for x-rays were comparable to the spacing between adjacent atoms in crystals. He therefore proposed that crystals be used to diffract x-rays, with their regular lattices acting



as a kind of three-dimensional grating. **The idea was tried and diffraction patterns were indeed obtained.**

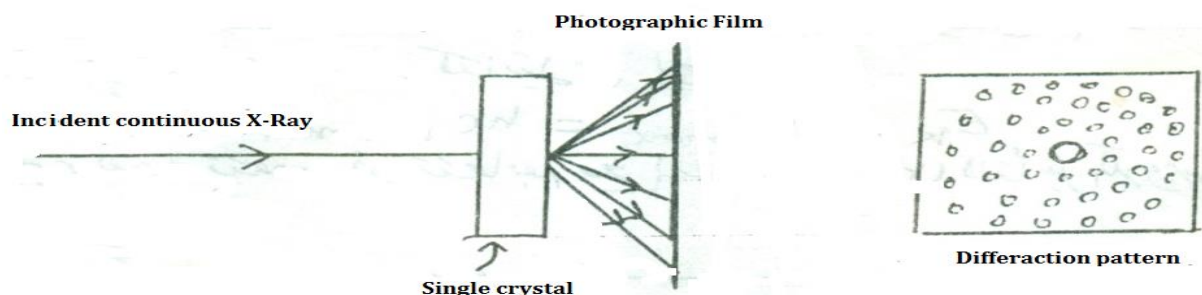

The pattern of the spots was characteristic of the crystal structure of the material being examined. In the case of Laue diffraction a continuous spectrum is used to irradiate the crystal; thus every crystal plane contributes to the diffraction pattern. **The result was viewed as confirmation of the wave nature of X-ray.**

**In 1913, Wifliam Bragg and his son Lawrence proposed a simple method of measuring the wavelengths of X-rays by means of their 'reflection' from crystal planes.**

Crystals comprise atoms (or ions) that are arranged in a spatial lattice, such that they define 'families' of parallel planes (Fig ). **The Braggs proposed that beams of X-rays would be reflected from these planes as though they were plane mirrors (Fig ).**

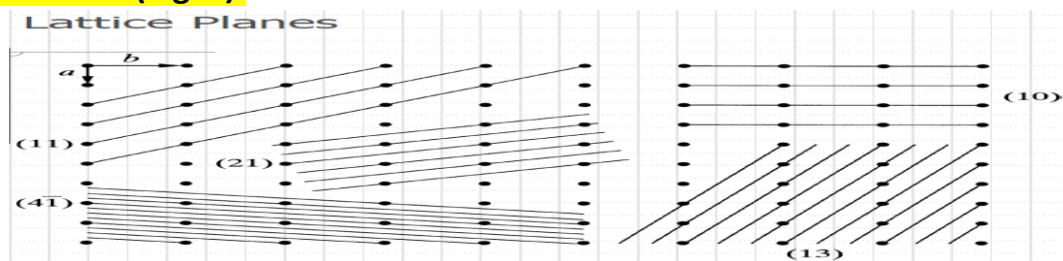

**The reflection of X-rays from a crystal plane can be understood in terms of Huygens' principle, in the same way as it explains the reflection of a beam of light from a plane mirror.** According to this principle, when a wave-front strikes a reflecting surface, each point on the surface acts as a source of secondary light waves, The **secondary** waves interfere constructively only where the angle of reflection of the beam **equals** its angle of incidence such that the new wave-front is the common tangent to these secondary waves (Fig 2.23). Similarly, when a beam

of X-rays is aimed at a crystal, its atoms act as sources of secondary waves and the beam is reflected at an angle equal to its angle of incidence.

The X-rays reflected from a family of parallel planes all emerge from the crystal at the same glancing angle  $\theta$  relative to the planes. However, the distances the rays have travelled inside the crystal may differ, depending on the depth of the plane from which they were reflected. Whether these rays interfere constructively or destructively when they are recombined in the reflected beam depends on their path difference.

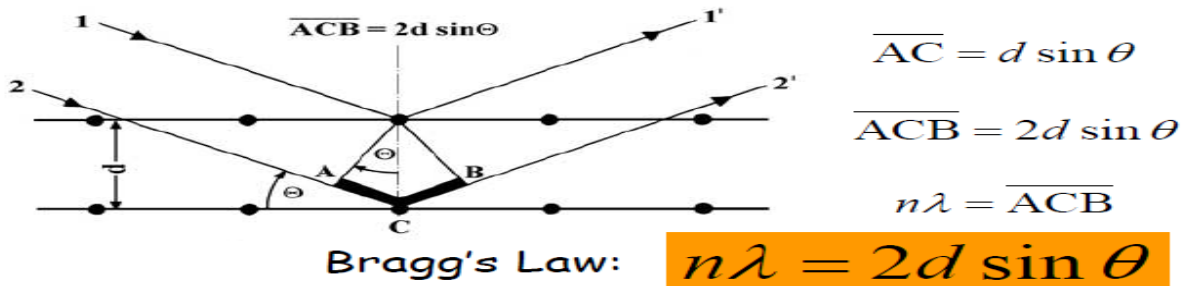

Consider rays reflected from two adjacent planes spaced at a distance  $d$ . The path difference between the rays is

$$AB + BC = 2d \sin \theta \quad (1)$$

Constructive interference occurs when the path difference equals an even number of half the radiation's wavelength:

$$n \lambda = 2d \sin \theta \quad (2)$$

at these angles, the reflected beam will then be of maximum intensity. The reflected beam of radiation will be of maximum intensity at glancing angles given by  $\theta = \sin^{-1} (n\lambda / 2d)$

Destructive interference occurs when the path difference equals an odd number of half the radiation's wavelength:

$$(2n + 1)\lambda = 2d \sin \theta \quad (n = 1, 2, 3, \dots) \quad (3)$$

at these angles, the reflected beam will then be of minimum intensity. The reflected beam of radiation will be of minimum intensity at glancing angles given by  $\theta = \sin^{-1} ( (2n+1)\lambda / 2d )$

## X-rays pectrophotometer

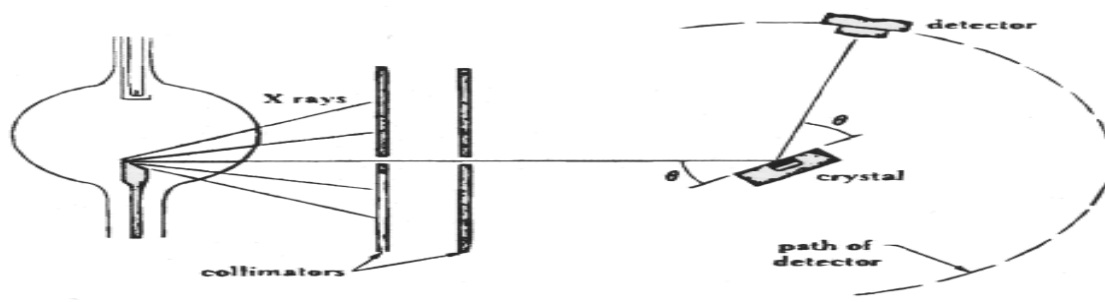

The x-ray spectrometer contains two collimating slits which confine the x-rays into a sharp beam. This beam falls upon the single crystal and some of the x-rays are diffracted in accordance with the Bragg equation.

### Uses of X-rays

- (i) In studying crystal structure: Structure of DNA was determined using X-ray diffraction.
- (ii) In medical science.
- (iii) In radiograph
- (iv) In radio therapy
- (v) In engineering
- (vi) In laboratories
- (vii) In detective department
- (viii) In art the change occurring in old oil paintings can be examined by X-rays.

### Concepts

- ☞ Nearly all metals emits photoelectrons when exposed to UV light. But alkali metals like lithium, sodium, potassium, rubidium and cesium emit photoelectrons even when exposed to visible light.
- ☞ Oxide coated filament in vacuum tubes is used to emit electrons at relatively lower temperature.
- ☞ Conduction of electricity in gases at low pressure takes because colliding electrons acquire higher kinetic energy due to increase in mean free path.
- ☞ Kinetic energy of cathode rays depends on both voltage and work function of cathode.
- ☞ Photoelectric effect is due to the particle nature of light.
- ☞ Hydrogen atom does not emit X-rays because it's energy levels are too close to each other.
- ☞ The essential difference between X-rays and of  $\gamma$ -rays is that,  $\gamma$ -rays emits from nucleus while X-rays from outer part of atom.
- ☞ There is no time delay between emission of electron and incidence of photon i.e. the electrons are emitted out as soon as the light falls on metal surface.

Lectures in Atomic Phys. (Modern phys.) Dr. Badry Abdalla- South Valley Unis-Faculty of sci- Phys. Dept.

- ☞ *If light were wave (not photons) it will take about an year take about an year to eject a photoelectron out of the metal surface.*
- ☞ *Doze of X-ray are measured in terms of produced ions or free energy via ionisaiton.*
- ☞ *Safe doze for human body per week is one Rontgen (One Rontgon is the amount of X-rays which emits  $2.5 \times 10^4$  J free energy through ionization of 1 gm air at NTP*

## Solved Problems

**Question 1 :** Calculate the energy released per carbon atom when 1 g of carbon is totally converted to energy.

**Answer 1 :** Energy E is expressed by Einstein's relation of  $E = mc^2$  where m is mass and c is the speed of light. If this relationship is utilized, considering SI unit that expresses mass in kg,

$$E = 1 \times 10^{-3} \times (2.998 \times 10^{10})^2 = 8.99 \times 10^{13} \text{ J}$$

The atomic weight per mole (molar mass) for carbon is 12.011 g from reference table (for example, Appendix A.2). Thus, the number of atoms included in 1 g carbon is calculated as  $(1/12.011) \times 0.6022 \times 10^{24} = 5.01 \times 10^{22}$  because the numbers of atoms are included in one mole of carbon is the Avogadro's number

$(0.6022 \times 10^{24})$  Therefore, the energy release per carbon atom can be estimated as:

$$\frac{(8.99 \times 10^{13})}{(5.01 \times 10^{22})} = 1.79 \times 10^{-9} \text{ J}$$

**Answer 2 :** The work, W , if electric charge Q (coulomb,C) moves under voltage V is expressed by  $W = V Q$ . When an electron is accelerated under 1V of difference in potential, the energy obtained by the electron is called 1 eV. Since the elementary charge e is  $1.602 \times 10^{-19} \text{ (C)}$ ,

$$\begin{aligned} 1\text{eV} &= 1.602 \times 10^{-19} \times 1 \quad (\text{C})(\text{V}) \\ &= 1.602 \times 10^{-19} \quad (\text{J}) \end{aligned}$$

Electric field E can be expressed with  $E = V / d$ , where the distance, d, between electrodes and the applied voltage being V . The force F on the electron with elementary charge e is given by;

$$F = eE \quad (\text{N})$$

Here, the unit of F is Newton. Acceleration , of electrons is given by the following equation in which m is the mass of the electron:

$$\alpha = \frac{eE}{m} \quad (\text{m/s}^2)$$

$$(1) E = \frac{10 \text{ (kV)}}{10 \text{ (mm)}} = \frac{10^4 \text{ (V)}}{10^{-2} \text{ (m)}} = 10^6 \quad (\text{V/m})$$

$$(2) F = 1.602 \times 10^{-19} \times 10^6 = 1.602 \times 10^{-13} \quad (\text{N})$$

$$(3) \alpha = \frac{1.602 \times 10^{-13}}{9.109 \times 10^{-31}} = 1.76 \times 10^{17} \quad (\text{m/s}^2)$$

**Question 3 :** X-rays are generated by making the electrically charged particles (electrons) with sufficient kinetic energy in vacuum collide with cathode, as widely used in the experiment of an X-ray tube. The resultant X-rays can be divided into two parts: continuous X-rays (also called white X-rays) and characteristic X-rays. The wavelength distribution and intensity of continuous X-rays are usually depending upon the applied voltage. A clear limit is recognized on the short wavelength side.

(1) Estimate the speed of electron before collision when applied voltage is 30,000V and compare it with the speed of light in vacuum.

(2) In addition, obtain the relation of the shortest wavelength limit  $\lambda_{\text{SWL}}$  of X-rays generated with the applied voltage  $V$ , when an electron loses all energy in a single collision.

**Answer 3 :** Electrons are drawn out from cathode by applying the high voltage of tens of thousands of V between two metallic electrodes installed in the X-ray tube in vacuum. The electrons collide with anode at high speed. The velocity of electrons is given by,

$$eV = \frac{mv^2}{2} \quad \rightarrow \quad v^2 = \frac{2eV}{m}$$

where  $e$  is the electric charge of the electron,  $V$  the applied voltage across the electrodes,  $m$  the mass of the electron, and  $v$  the speed of the electron before the

collision. When values of rest mass  $m_e = 9.110 \times 10^{-31}$  .kg as mass of electron, elementary electron charge  $e = 1.602 \times 10^{-19}$  C and  $V = 3 \times 10^4$  .V are used for calculating the speed of electron  $v$ .

$$v^2 = \frac{2 \times 1.602 \times 10^{-19} \times 3 \times 10^4}{9.110 \times 10^{-31}} = 1.055 \times 10^{16}, \quad v = 1.002 \times 10^8 \text{ m/s}$$

Therefore, the speed of electron just before impact is about one-third of the speed of light in vacuum ( $v = 2.998 \times 10^8$  m/s).

Some electrons release all their energy in a single collision. However, some other electrons behave differently. The electrons slow down gradually due to successive collisions. In this case, the energy of electron (eV) which is released partially and the corresponding X-rays (photon) generated have less energy compared with the energy ( $h_{\max}$ ) of the X-rays generated when electrons are stopped with one collision. This is a factor which shows the maximum strength moves toward the shorter wavelength sides, as X-rays of various wavelengths generate, and higher the intensity of the applied voltage, higher the strength of the wavelength of X-rays (see Fig. 1). Every photon has the energy  $h_{\nu}$ , where  $h$  is the Planck constant and  $\nu$  the frequency.

The relationship of  $eV = h\nu_{\max}$  can be used, when electrons are stopped in one impact and all energy is released at once. Moreover, frequency ( $\nu$ ) and wavelength ( $\lambda$ ) are described by a relation of  $\lambda = c / \nu$  where  $c$  is the speed of light. Therefore, the relation between the wavelength  $\lambda_{SWL}$  in m and the applied voltage  $V$  may be given as follows:

$$\lambda_{SWL} = c/\nu_{\max} = hc/eV = \frac{(6.626 \times 10^{-34}) \times (2.998 \times 10^8)}{(1.602 \times 10^{-19})V} = \frac{(12.40 \times 10^{-7})}{V}$$

This relation can be applied to more general cases, such as the production of electromagnetic waves by rapidly decelerating any electrically charged particle including electron of sufficient kinetic energy, and it is independent of the anode material. When wavelength is expressed in nm, voltage in kV, and the relationship becomes  $\lambda V = 1.240$ .

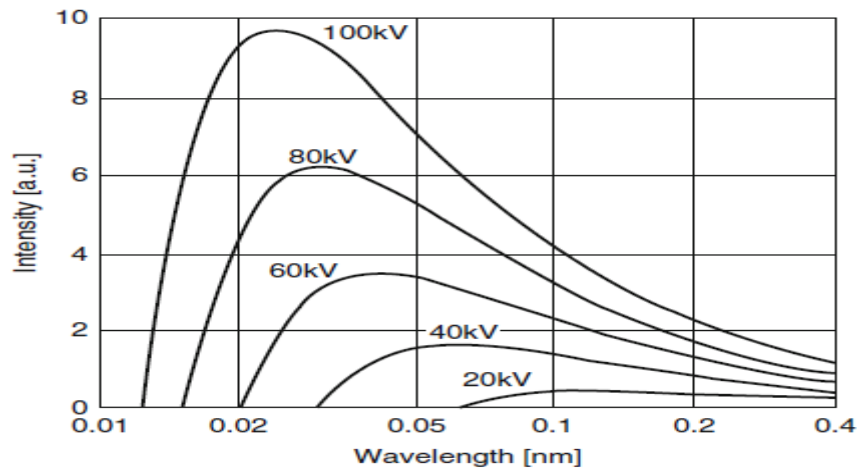

**Fig. 1 Schematic diagram for X-ray spectrum as a function of applied voltage**

**Reference:** The electrons released from a filament have sufficient kinetic energy and collide with the Fe target. Therefore, an electron of K-shell is readily ejected. This gives the state of FeC ion left in an excited state with a hole in the K-shell. When this hole is filled by an electron from an outer shell (L-shell), an X-ray photon is emitted and its energy is equal to the difference in the two electron energy levels. This variation responds to the following electron arrangement of FeC.

Before release	K1	L8	M14	N2
After release	K2	L7	M14	N2

**Question 4 :**  $K\alpha_1$  radiation of Fe is the characteristic X-rays emitted when one of the electrons in L shell falls into the vacancy produced by knocking an electron out of the K-shell, and its wavelength is 0.1936 nm. Obtain the energy difference related to this process for X-ray emission.

**Answer 4 :** Consider the process in which an L shell electron moves to the vacancy created in the K shell of the target (Fe) by collision with highly accelerated electrons from a filament. The wavelength of the photon released in this process is given by  $\lambda$  (with frequency  $\nu$ ). We also use Planck's constant  $h$  of ( $6.626 \times 10^{-34}$  Js ) and the velocity of light  $c$  of ( $2.998 \times 10^8$  m/ s). Energy per photon is given by:

$$E = h\nu = \frac{hc}{\lambda}$$



Using Avogadro's number  $N_A$ , one can obtain the energy difference  $\Delta E$  related to the X-ray release process per mole of Fe.

$$\begin{aligned}\Delta E &= \frac{N_A hc}{\lambda} = \frac{0.6022 \times 10^{24} \times 6.626 \times 10^{-34} \times 2.998 \times 10^8}{0.1936 \times 10^{-9}} \\ &= \frac{11.9626}{0.1936} \times 10^{-7} = 6.1979 \times 10^8 \text{ J/mole}\end{aligned}$$

**Question 5 :** Explain atomic density and electron density.

**Answer 5 :** The atomic density  $N_a$  of a substance for one-component system is given by the following equation, involving atomic weight  $M$ , Avogadro's number  $N_A$ , and the density  $\rho$ .

$$N_a = \frac{N_A}{M} \rho. \quad (1)$$

In the SI system,  $N_a$  ( $\text{m}^{-3}$ ),  $N_A = 0.6022 \times 10^{24}$  ( $\text{mol}^{-1}$ )  $\rho$  ( $\text{kg} / \text{m}^3$ ), and  $M$  ( $\text{kg} / \text{mol}$ ), respectively. The electron density  $N_e$  of a substance consisting of single element is given by:

$$N_e = \frac{N_A}{M} Z \rho \quad (2)$$

Each atom involves  $Z$  electrons (usually  $Z$  is equal to the atomic number) and the unit of  $N_e$  is also  $\text{m}^{-3}$ .

The quantity  $N_a = N_A / M$  in (1) or  $N_e = (N_A Z) / M$  in (2), respectively, gives the number of atoms or that of electrons per unit mass ( $\text{kg}$ ), when excluding density,  $\rho$ . They are frequently called "atomic density" or "electron density." However, it should be kept in mind that the number per  $\text{m}^3$  (per unit volume) is completely different from the number per 1  $\text{kg}$  (per unit mass). For example, the following values of atomic number and electron number per unit mass (= 1 $\text{kg}$ ) are obtained for aluminum with the molar mass of 26.98  $\text{g}$  and the atomic number of 13.

$$N_a = \frac{0.6022 \times 10^{24}}{26.98 \times 10^{-3}} = 2.232 \times 10^{25} \quad (\text{kg}^{-1})$$

$$N_e = \frac{0.6022 \times 10^{24}}{26.98 \times 10^{-3}} \times 13 = 2.9 \times 10^{26} \quad (\text{kg}^{-1})$$

Since the density of aluminum is  $2.70 \text{ Mg} / \text{m}^3 = 2.70 \times 10^3 \text{ kg} / \text{m}^3$  from reference table , we can estimate the corresponding values per unit volume s

$N_a = 6.026 \times 10^{28} \text{ (m}^{-3}\text{)}$  and  $N_e = 7.83 \times 10^{29} \text{ (m}^{-3}\text{)}$ , respectively.

**Reference:** Avogadro's number provides the number of atom(or molecule) included in one mole of substance. Since the atomic weight is usually expressed by the number of grams per mole, the factor of  $10^{-3}$  is required for using Avogadro's number in the SI unit system.

**Question 6:** The energy of a photoelectron,  $E_{ej}$ , emitted as the result of photoelectron absorption process may be given in the following with the binding energy  $E_B$  of the electron in the corresponding shell.

$$E_{ej} = h\nu - E_B$$

Here,  $h\nu$  is the energy of incident X-rays, and this relationship has been obtained with an assumption that the energy accompanying the recoil of atom, which necessarily occurs in photoelectron absorption, is negligible.

Calculate the energy accompanying the recoil of atom in the following condition for Pb. The photoelectron absorption process of K shell for Pb was made by irradiating X-rays with the energy of 100 keV against a Pb plate and assuming that the momentum of the incident X-rays was shared equally by Pb atom and photoelectron. In addition, the molar mass (atomic weight) of Pb is 207.2 g and the atomic mass unit is  $1 \text{ amu} = 1.66054 \times 10^{-27} \text{ kg} = 931.5 \times 10^3 \text{ keV}$ .

**Answer 6 :** The energy of the incident X-rays is given as 100 keV, so that its momentum can be described as being  $100 \text{ keV}/c$ , using the speed of light  $c$ . Since the atom and photoelectron shared the momentum equally, the recoil energy of atom will be  $50 \text{ keV}/c$ . Schematic diagram of this process is illustrated in Fig. 1.

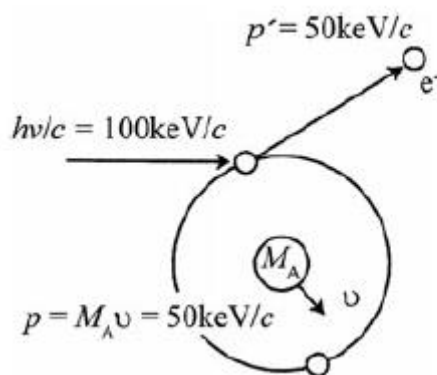

Fig. 1 Schematic diagram for the photo electron absorption process assuming that the momentum of the incident X-rays was shared equally by atom and photoelectron. Energy of X-ray radiation is 100 keV

On the other hand, one should consider for the atom that 1amu D 931:5\_103 keV is used in the same way as the energy which is the equivalent energy amount of the rest mass for electron,  $m_e$ . The molar mass of 207.2 g for Pb is equivalent to 207.2 amu, so that the mass of 1 mole of Pb is equivalent to the energy of  $207.2 \times 931.5 \times 10^3 = 193006.8 \times 10^3$  keV/c.

When the speed of recoil atom is  $v$  and the molar mass of Pb is  $M_A$ , its energy can be expressed by  $\frac{1}{2} M_A v^2$ . According to the given assumption and the momentum described as  $p = M_A v$ , the energy of the recoil atom,  $E_r^A$ , may be obtained as follows:

$$E_r^A = \frac{1}{2} M_A v^2 = \frac{p^2}{2M_A} = \frac{(50)^2}{2 \times (193006.8 \times 10^3)} = 0.0065 \times 10^{-3} \quad (\text{keV})$$

The recoil energy of atom in the photoelectron absorption process shows just a very small value as mentioned here using the result of Pb as an example, although the recoil of the atom never fails to take place.

#### Reference:

$$\text{Energy of 1 amu} = \frac{1.66054 \times 10^{-27} \times (2.99792 \times 10^8)^2}{1.60218 \times 10^{-19}} = 9.315 \times 10^8 \quad (\text{eV})$$

On the other hand, the energy of an electron with rest mass  $m_e = 9.109 \times 10^{-31}$  kg can be obtained in the following with the relationship of  $1 \text{ eV} = 1.602 \times 10^{-19} \text{ J}$ :

$$E = m_e c^2 = \frac{9.109 \times 10^{-31} \times (2.998 \times 10^8)^2}{1.602 \times 10^{19}} = 0.5109 \times 10^6 \text{ (eV)}$$

---

**Question 7 :** Explain the Rydberg constant in Moseley's law with respect to the wavelength of characteristic X-rays, and obtain its value.

**Answer 7 :** Moseley's law can be written as,

$$\frac{1}{\lambda} = R(Z - S_M)^2 \left( \frac{1}{n_1^2} - \frac{1}{n_2^2} \right) \quad (1)$$

The wavelength of the X-ray photon  $\lambda$  corresponds to the shifting of an electron from the shell of the quantum number  $n_2$  to the shell of the quantum number of  $n_1$ . Here,  $Z$  is the atomic number and  $S_M$  is a screening constant.

Using the elementary electron charge of  $e$ , the energy of electron characterized by the circular movement around the nucleus charge  $Ze$  in each shell (orbital) may be given, for example, with respect to an electron of quantum number  $n_1$  shell in the following form:

$$E_n = -\frac{2\pi^2 m e^4 Z^2}{h^2 n_1^2} \quad (2)$$

Here,  $h$  is a Planck constant and  $m$  represents the mass of electron. The energy of this photon is given by,

$$h\nu = E_{n_2} - E_{n_1} = \Delta E = \frac{2\pi^2 m e^4}{h^2} Z^2 \left( \frac{1}{n_1^2} - \frac{1}{n_2^2} \right) \quad (3)$$

The following equation will also be obtained, if the relationship of  $E = h\nu = hc/\lambda$  is employed while using the velocity of photon,  $c$ :

$$\frac{1}{\lambda} = \frac{2\pi^2 m e^4}{ch^3} Z^2 \left( \frac{1}{n_1^2} - \frac{1}{n_2^2} \right) \quad (4)$$

If the value of electron mass is assumed to be rest mass of electron and a comparison of (1) with (4) is made, the Rydberg constant  $R$  can be estimated. It may be noted that the term of  $(Z - S_M)^2$  in (1) could be empirically obtained from the measurements on various characteristic X-rays as reported by H.G.J. Moseley in 1913.

$$R = \frac{2\pi^2 me^4}{ch^3} = \frac{2 \times (3.142)^2 \times (9.109 \times 10^{-28}) \times (4.803 \times 10^{-10})^4}{(2.998 \times 10^{10}) \times (6.626 \times 10^{-27})^3}$$

$$= 109.743 \times 10^3 (\text{cm}^{-1}) = 1.097 \times 10^7 (\text{m}^{-1}) \quad (5)$$

The experimental value of R can be obtained from the ionization energy (-13.6 eV) of hydrogen (H). The corresponding wave number (frequency) is  $109737:31 \text{ cm}^{-1}$ , in good agreement with the value obtained from (5). In addition, since Moseley's law and the experimental results are all described by using the cgs unit system (gauss system),  $4.803 \times 10^{-10}$  esu has been used for the elemental electron charge e. Conversion into the SI unit system is given by (SI unit  $\times$  velocity of light  $\times 10^{-1}$ ) (e.g., 5th edition of the Iwanami Physics-and-Chemistry Dictionary p. 1526 (1985)). That is to say, the amount of elementary electron charge e can be expressed as:

$$1.602 \times 10^{-19} \text{Coulomb} \times 2.998 \times 10^{10} \text{ cm/s} \times 10^{-1} = 4.803 \times 10^{-10} \text{ esu}$$

The Rydberg constant is more strictly defined by the following equation:

$$R = \frac{2\pi^2 \mu e^4}{ch^3} \quad (6)$$

$$\frac{1}{\mu} = \frac{1}{m} + \frac{1}{m_p} \quad (7)$$

Here, m is electron mass and  $m_p$  is nucleus (proton) mass. The detected difference is quite small, but the value of  $m_p$  depends on the element. Then, it can be seen from the relation of (6) and (7) that a slightly different value of R is obtained for each element. However, if a comparison is made with a hydrogen atom, there is a difference of about 1,800 times between the electron mass  $m_e = 9.109 \times 10^{-31} \text{ kg}$  and the proton mass which is  $m_p = 1.67 \times 10^{-27} \text{ kg}$ . Therefore, the relationship of (6) is usually treated as  $\mu = m$ , because  $m_p$  is very large in comparison with  $m_e$ .

$$R = \frac{2\pi^2 \mu e^4}{ch^3} \times \left( \frac{1}{4\pi\epsilon_0} \right)^2 = \frac{me^4}{8\epsilon_0^2 ch^3}$$

$$= \frac{9.109 \times 10^{-31} \times (1.602 \times 10^{-19})^4}{8 \times (8.854 \times 10^{-12})^2 \times (2.998 \times 10^8) \times (6.626 \times 10^{-34})^3}$$

$$= \frac{9.109 \times (1.602)^4 \times 10^{-107}}{8 \times (8.854)^2 \times (2.998) \times (6.626)^3 \times 10^{-118}} = 1.097 \times 10^7 (\text{m}^{-1})$$

**Reference:** The definition of the Rydberg constant in the SI unit is given in the form where the factor of  $1/4\pi\epsilon_0$  is included by using the dielectric constant  $\epsilon_0$  ( $8.854 \times 10^{-12}$  F/m) in vacuum for correlating with nucleus charge  $Z_e$ .

---

**Question 8:** There is a substance of linear absorption coefficient  $\mu$ .

(1) Obtain a simple relation to give the sample thickness  $x$  required to reduce the amount of transmitted X-ray intensity by half.

(2) Calculate also the corresponding thickness of Fe-17 mass % Cr alloy (density =  $7.76 \times 10^6$  g / m<sup>3</sup>) for Mo-K<sub>α</sub> radiation, using the relation obtained in (1).

**Answer 8:** Let us consider the intensity of the incident X-rays as  $I_0$  and that of the transmitted X-rays as  $I$ . Then,

$$I = I_0 e^{-\mu x} \quad (1)$$

If the condition of  $I = \frac{I_0}{2}$  is imposed, taken into account, one obtains,

$$\frac{I_0}{2} = I_0 e^{-\mu x} \quad (2)$$

$$\frac{1}{2} = e^{-\mu x} \quad (3)$$

When the logarithm of both sides is taken, we obtain  $\log 1 - \log 2 = -\mu x \log e$ . The result is  $-\log 2 = \mu x$ , as they are  $\log 1 = 0$ , and  $\log e = 1$ . Here, natural logarithm is used and the required relation is given as follows:

$$x = \frac{\log 2}{\mu} \simeq \frac{0.693}{\mu} \quad (4)$$

The values of mass absorption coefficients of Fe and Cr for the Mo-K<sub>α</sub> radiation are 37.6 and 29.9 cm<sup>2</sup>/g obtained from Appendix reference table, respectively. The concentration of Cr is given by 17 mass %, so that the weight ratio of two alloy components can be set as  $w_{Fe} = 0.83$  and  $w_{Cr} = 0.17$ . Then, the mass absorption coefficient of the alloy is expressed in the following:

$$\begin{aligned}\left(\frac{\mu}{\rho}\right)_{\text{Alloy}} &= w_{\text{Fe}} \left(\frac{\mu}{\rho}\right)_{\text{Fe}} + w_{\text{Cr}} \left(\frac{\mu}{\rho}\right)_{\text{Cr}} \\ &= 0.83 \times (37.6) + 0.17 \times (29.9) = 36.3 \text{ (cm}^2/\text{g)}\end{aligned}$$

Next, note that the unit of the density of the Fe–Cr alloy is expressed in cgs,  $7.76 \times 10^6 \text{ g / m}^3 = 7.76 \text{ g / cm}^3$ . We obtain,

$$\mu_{\text{Alloy}} = 36.3 \times 7.76 \text{ (cm}^{-1}\text{)} = 281.7 \text{ (cm}^{-1}\text{)}$$

$$x = \frac{0.693}{281.7} = 0.0025 \text{ cm} = 0.025 \text{ mm} = 25 \mu\text{m}$$

**9-Question 1.10** Calculate the mass absorption coefficient of lithium niobate ( $\text{LiNbO}_3$ ) for Cu- $K_\alpha$  radiation.

**10-Question 1.11** A thin plate of pure iron is suitable for a filter for Co- $K_\alpha$  radiation, but it is also known to easily oxidize in air. For excluding such difficulty, we frequently utilize crystalline hematite powder ( $\text{Fe}_2\text{O}_3$ : density  $5.24 \times 10^6 \text{ g/m}^3$ ). Obtain the thickness of a filter consisting of hematite powder which reduces the intensity of Co- $K_\beta$  radiation to 1/500 of the  $K_\alpha$  radiation case. Given condition is as follows. The intensity ratio between Co- $K_\alpha$  and Co- $K_\beta$  is found to be given by 5:1 without a filter. The packing density of powder sample is known usually about 70% of the bulk crystal.

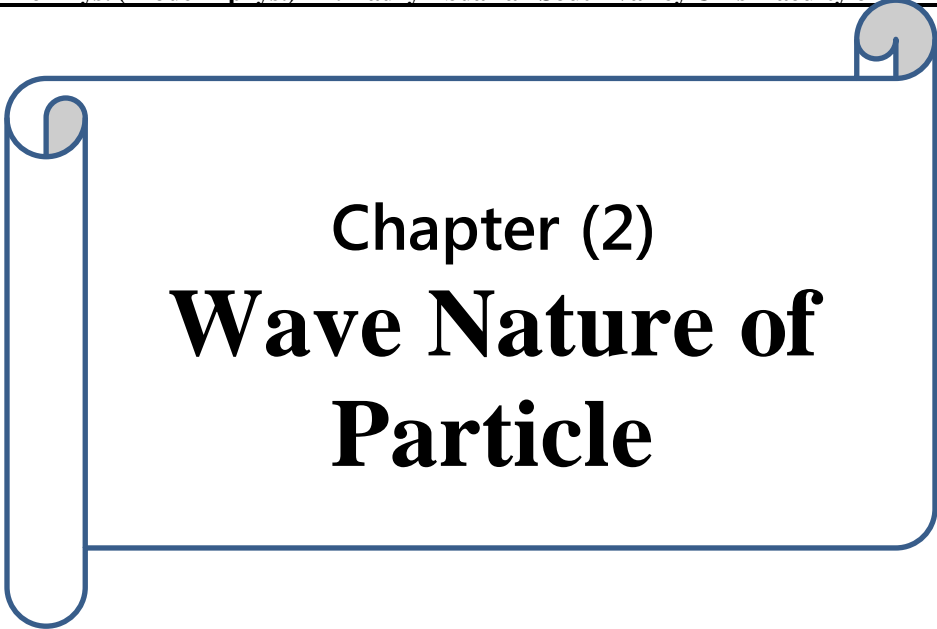

Chapter (2)  
**Wave Nature of  
Particle**



## Chapter (2)

### Wave Nature of Particles

#### **Matter waves (De Broglie's Hypothesis)**

In the early 20<sup>th</sup> Century (1924) DeBroglie proposed that, since light, which was then considered to be a purely wave phenomenon, had been found to appear sometimes to exhibit particle behavior; perhaps matter, which was accepted as being particle in nature might sometimes exhibit wave behavior. DeBroglie reasoned that, the wavelength of a photon being equal to Planck's constant divided by the photon's momentum, the same relationship should apply to a particle of matter .

Theory and experiment indicate that waves sometimes act like particles (photons) and particles can sometimes act like waves. In experiments like photoelectric effect and Compton effect, radiation behaves like particles.

De Broglie asked whether in some situations, the reverse could be true, i.e., would objects which are generally regarded as particles (e.g. electrons) behave like waves ?.

The wave associated with moving particle is called matter wave or de-Broglie wave ( $\lambda = h / P$ ) and it propagates in the form of wave packets with group velocity  $V_g$  .

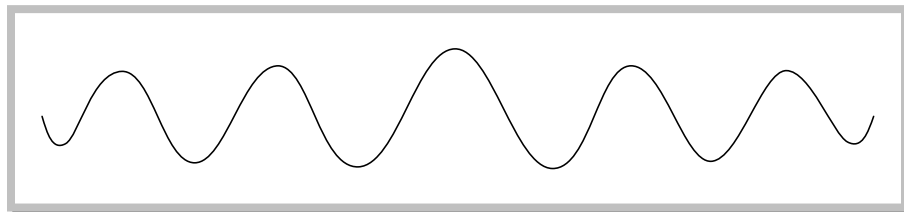

**1-Derivation of De Broglie's Law :**

First considering a photon, its energy is :

$$E_w = h\nu \text{ -----(1),}$$

and the energy equivalent of a mass,  $m$ , is :

$$E_m = mC^2 \text{ -----(2),}$$

While the photon's rest mass is zero it has kinetic mass corresponding to its energy. If the photon equivalent mass,  $m$ , actually appears as a wave its energy as a wave must be the same as its energy as a mass. Therefore

$$E_w = E_m$$

$$h\nu = mC^2 \text{ -----(3)}$$

$$m = h\nu / C^2 \text{ -----(4)}$$

Where,  $\nu = C / \lambda$

Then,  $m = h / \lambda c \text{ -----(5)}$

And finally,

$$\lambda = h / mc \text{ -----(6)}$$

$\lambda = h / P = \frac{h}{\text{photon momentum}}$
--

**Other Derivation :**

According to Special Relativity (and Maxwell's equations) light of energy  $E$  carries momentum  $p = \frac{E}{c}$ . De Broglie argues that the same equations apply to particles and introduces the idea of *matter waves*.

From Relativity :  $E = m_o C^2 = (m^2_o C^4 + P^2 C^2)^{1/2}$  at  $m_o = 0$

Then ,  $P = E / C \text{ .....(1)}$

From Planck Energy Equation:  $E = h\nu = hC / \lambda$

Then,  $E / C = h / \lambda \text{ .....(2)}$

From eqs (1) and (2) we have :

$\lambda = h / P \text{ .....(3)}$
------------------------------------

**Notes: For photons:**  $E_\gamma = hf = h \frac{c}{\lambda}$  . and  $p_\gamma = \frac{E_\gamma}{c} = \frac{h}{\lambda} = \hbar k$ .

$$\text{de Broglie relations: } E = hf = \hbar \omega , \quad p = \frac{h}{\lambda} = \hbar k$$

**2-De-Broglie wavelength**

According to de-Broglie theory, the wavelength of de-Broglie wave

is given by 
$$\lambda = \frac{h}{p} = \frac{h}{mv} = \frac{h}{\sqrt{2mE}} \quad \Rightarrow \quad \lambda \propto \frac{1}{p} \propto \frac{1}{v} \propto \frac{1}{\sqrt{E}}$$

Where  $h$  = Plank's constant,  $m$  = Mass of the particle,  $v$  = Speed of the particle,  $E$  = Energy of the particle. The smallest wavelength whose measurement is possible is that of  $\gamma$ -rays. The wavelength of matter waves associated with the microscopic particles like electron, proton, neutron,  $\alpha$ -particle *etc.* is of the order of  $10^{-10} m$ .

**(i) de-Broglie wavelength associated with the charged particles.**

The energy of a charged particle accelerated through potential

difference  $V$  is 
$$E = \frac{1}{2}mv^2 = qV$$

Hence de-Broglie wavelength 
$$\lambda = \frac{h}{p} = \frac{h}{\sqrt{2mE}} = \frac{h}{\sqrt{2mqV}}$$

$$\lambda_{electron} = \frac{12.27}{\sqrt{V}} \text{ \AA}, \quad \lambda_{proton} = \frac{0.286}{\sqrt{V}} \text{ \AA}, \quad \lambda_{neutron} = \frac{0.202 \times 10^{-10}}{\sqrt{V}} \text{ \AA},$$

$$\lambda_{\alpha\text{-particle}} = \frac{0.101}{\sqrt{V}} \text{ \AA}$$

**(ii) de-Broglie wavelength associated with uncharged particles.**

For Neutron de-Broglie wavelength is given as

$$\lambda_{Neutron} = \frac{0.286 \times 10^{-10}}{\sqrt{E(\text{in eV})}} m = \frac{0.286}{\sqrt{E(\text{in eV})}} \text{ \AA}$$

Energy of thermal neutrons at ordinary temperature

$$\therefore E = kT \Rightarrow \lambda = \frac{h}{\sqrt{2mkT}}; \quad \text{where } k = \text{Boltzman's constant} = 1.38 \times 10^{-23} \text{ Joules/kelvin}, T = \text{Absolute temp.}$$

So

$$\lambda_{\text{Thermal Neutron}} = \frac{6.62 \times 10^{-34}}{\sqrt{2 \times 1.07 \times 10^{-17} \times 1.38 \times 10^{-23} T}} = \frac{30.83}{\sqrt{T}} \text{ \AA}$$

### Some graphs

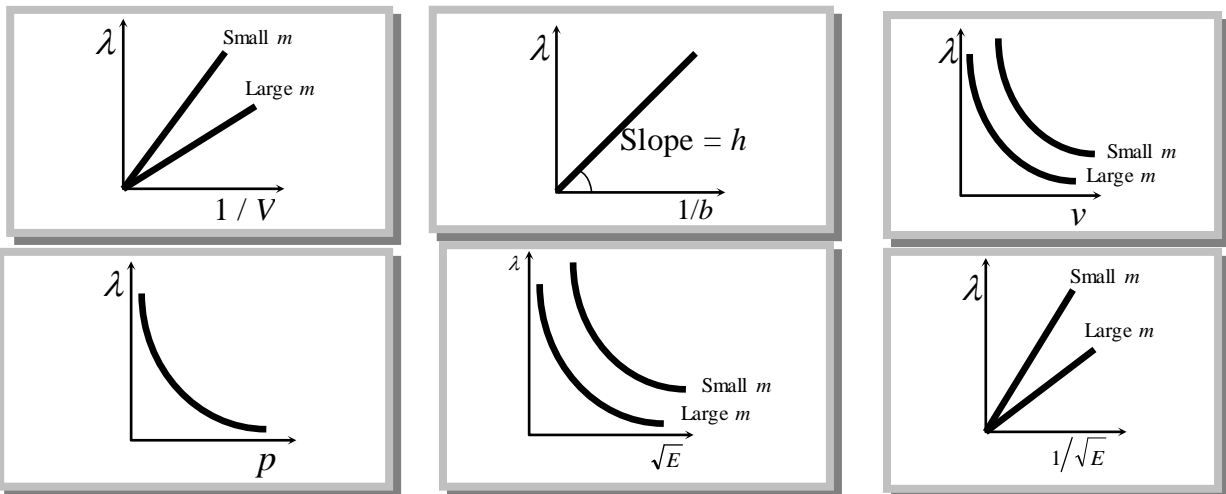

### Notes :

- A photon is not a material particle. It is a quanta of energy.
- When a particle exhibits wave nature, it is associated with a wave packet, rather than a wave.

### (3) Characteristics of matter waves

- Matter wave represents the probability of finding a particle in space.
- Matter waves are not electromagnetic in nature.
- De-Broglie or matter wave is independent of the charge on the material particle. It means, matter wave of de-Broglie wave is associated with every moving particle (whether charged or uncharged).

- Practical observation of matter waves is possible only when the de-Broglie wavelength is of the order of the size of the particles in nature.
- Electron microscope works on the basis of de-Broglie waves.
- The electric charge has no effect on the matter waves or their wavelength.
- The phase velocity of matter waves can be greater than the speed of light.
- Matter waves can propagate in vacuum, hence they are not mechanical waves.
- The number of de-Broglie waves associated with  $n^{\text{th}}$  orbital electron is  $n$ .
- Only those circular orbits around the nucleus are stable whose circumference is integral multiple of de-Broglie wavelength associated with the orbital electron.

#### 4- Experimental Varification of De Broglie's Hypothesis

##### (4-1) Davision and Germer experiment

This is the first experiment which confirmed the wave nature of electrons. It is used to study the scattering of electron from a solid or to verify the wave nature of electron. A beam of electrons emitted by electron gun is made to fall on nickel crystal cut along cubical axis at a particular angle. *Ni* crystal behaves like a three dimensional diffraction grating and it diffracts the electron beam obtained from electron gun.

The diffracted beam of electrons is received by the detector which can be positioned at any angle by rotating it about the point of incidence

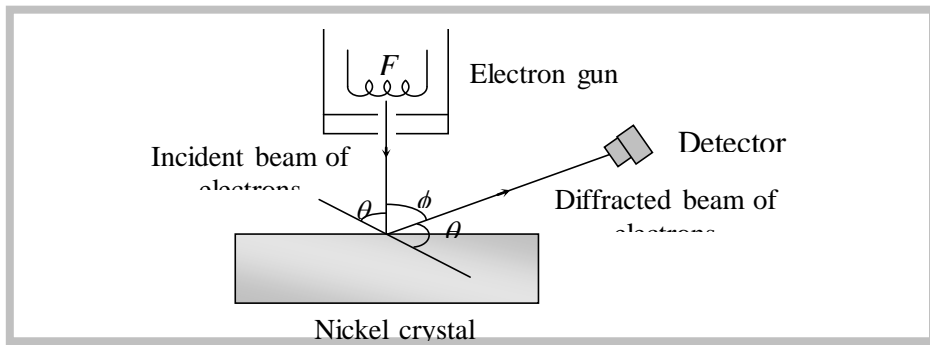

The energy of the incident beam of electrons can also be varied by changing the applied voltage to the electron gun. According to classical physics, the intensity of scattered beam of electrons at all scattering angle will be same but Davisson and Germer, found that the intensity of

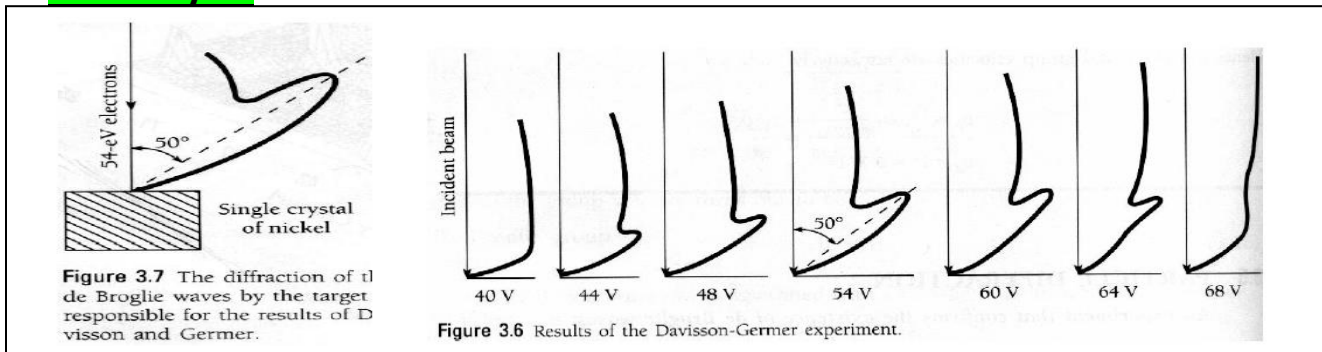

scattered beam of electrons was not the same but different at different angles of scattering. Intensity is maximum at 54 V potential difference and 50° diffraction angle.

If the de-Broglie waves exist for electrons then these should be diffracted as X-rays. Using the Bragg's formula  $2d \sin \theta = n\lambda$ , we can determine the wavelength of these waves.

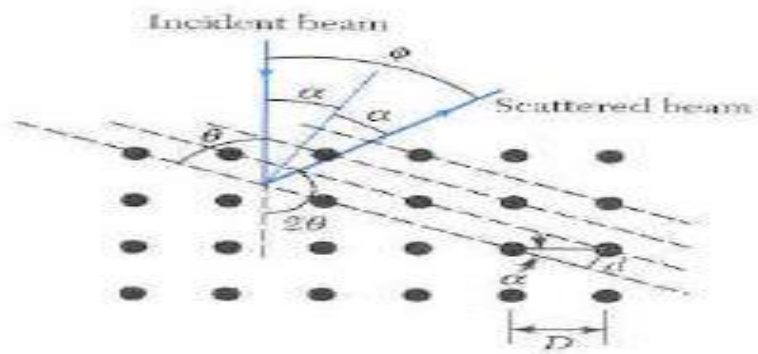

Where  $D =$  distance between diffracting planes,  $\theta = \frac{(180 - \phi)}{2} =$  glancing angle for incident beam = Bragg's angle. The distance between diffraction planes in Ni-crystal for this experiment is  $d = 0.91\text{\AA}$  and the

Bragg's angle =  $65^\circ$ . This gives for  $n = 1$ ,

$$\lambda = 2 \times 0.91 \times 10^{-10} \sin 65^\circ = 1.65 \text{ \AA}$$

Now the de-Broglie wavelength can also be determined by using the formula

$$\lambda = \frac{12.27}{\sqrt{V}} = \frac{12.27}{\sqrt{54}} = 1.67 \text{ \AA}$$

**Thus the de-Broglie hypothesis is verified.**

The only detail that matters for us is that the nickel crystals in such an experiment act very much like the two slits, except that a beam of electrons is used in place of a beam of light. They found something remarkable. A pattern very much akin to interference patterns emerged.

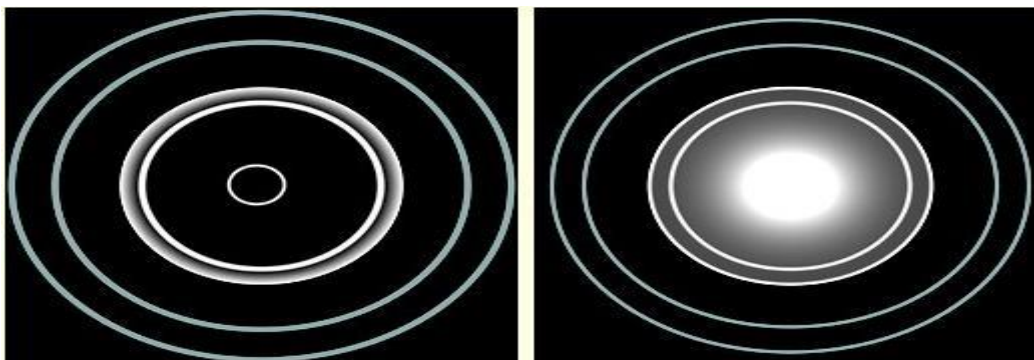

Electron Diffraction

X-ray Diffraction

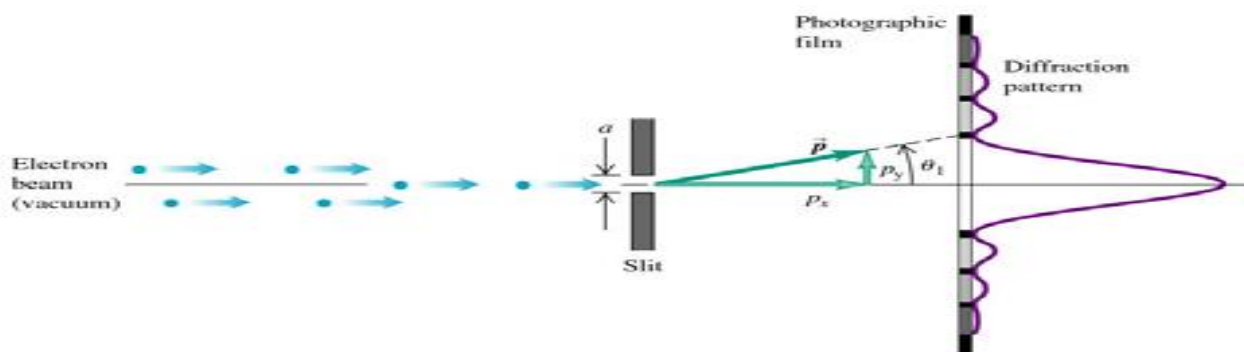

**Their experiment therefore showed that electrons exhibit interference phenomena,** the telltale sign of **waves.** At dark spots, electrons were somehow "canceling each other out." Even if the beam of fired electrons was "thinned" so that, for instance, only one electron was emitted every ten seconds, **the individual electrons still built up the bright and dark bands—one spot at a time.**

Somehow, as with photons, individual electrons "interfere" with themselves in the sense that individual electrons, over time, reconstruct the interference pattern associated with waves. We are inescapably forced to conclude that each electron embodies a wave-like character in conjunction with its more familiar depiction as a particle.

**2-Electron diffraction- Thomson's Experiment**

The wave character of the electron was demonstrated independently in 1937 by George Thomson. He found that circular diffraction pattern were produced when a narrow beam of high energy electrons was aimed through a thin metal foil . Diffraction fringes were also observed. This result confirmed again the wave behavior of electrons.

When using an aluminum foil, Thomson obtained the following vales for the radius  $r$  , of the first order circle in the diffraction pattern and the corresponding potential  $V$ , through which the electrons had been accelerated.

$V$ (volts)	$r$ (mm)	$V$ (volts)	$r$ (mm)
17,500	3.10	44,000	2.08
30,500	2.45	48,600	1.98
31,800	2.34	56,500	1.80
40,000	2.12		

**Do these values confirm De Broglie hypotheses?**

The row of atoms in the micro-crystal lattice, and each micro-crystal can act as a diffraction grating for waves of appropriate wavelength  $\lambda$  . The lattices are identical and so the diffraction pattern they produce will be identical. However, because they are randomly scattered through the foil, these pattern will likewise be oriented randomly. The



overall result is a circular diffraction pattern, the foil act as though it was a single grating, rotating **about an axis normal to its plane**.

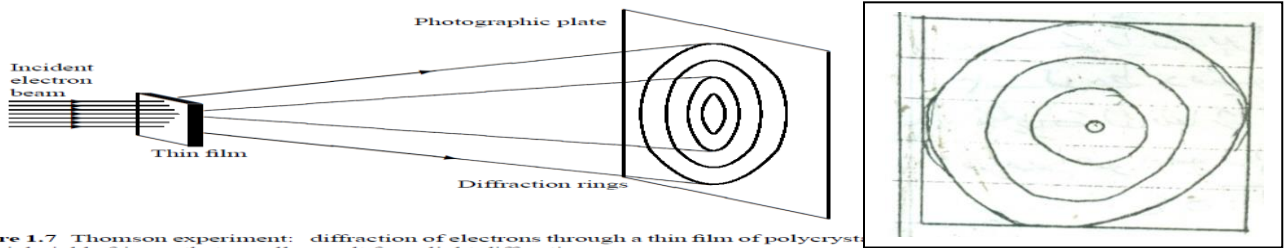

Figure 1.7 Thomson experiment: diffraction of electrons through a thin film of polycrystalline material yields fringes that usually result from light diffraction.

As with any diffraction grating, interference is obtained at the angles given :

$$d \sin \theta_n = n\lambda \quad (n = 1, 2, 3, \dots)$$

Where  $d$  is the spacing of the grating. The radius of the first order circle in the diffraction pattern is much smaller than the distance  $L$  from the foil to the screen and so to the close approximation

$$\sin \theta_1 = \tan \theta_1 = r/L$$

Thus, the wavelength of the corresponding to the diffraction pattern is :

$$\lambda = dr/L$$

According to the hypothesis of De Broglie, the wavelength of electrons accelerated with potential  $V$  is given by :

$$\lambda = \frac{h}{\sqrt{2m_e eV}}$$

If the experimental values of the wavelength equal that predicted by De Broglie's hypothesis

or alternatively,

$$\frac{dr}{L} = \frac{h}{\sqrt{2m_e eV}}$$

$$r\sqrt{V} = \frac{Lh}{d\sqrt{2m_e e}}$$

For a particular experimental set-up, all the component quantities of the product  $\frac{Lh}{d\sqrt{2} m_0 e}$  are constant. De Broglie hypothesis will be confirmed, therefore, if the product  $r \sqrt{V}$  is constant for a series of measurements with the particular set-up. Examination of the data in the table above shows that in each case the product falls within the range

$$r\sqrt{V} = (425 \pm 15) \cdot 10^{-3} \text{ m} \cdot \text{V}^{1/2}$$

**A result that confirms the hypothesis within the experimental error.**

Thomson, reported his experiments, in which a beam of energetic electrons was diffracted by a thin foil. Thomson found patterns that resembled the x-ray patterns made with powdered (polycrystalline) samples. This kind of diffraction, by many randomly oriented crystalline grains, produces rings. If the wavelength of the electrons is changed by changing their incident energy, the diameters of the diffraction rings change proportionally, as expected from Bragg's equation.

The diffraction patterns simulated above compare the effects of x-rays passing through a thin foil with those of high energy electrons passing through the same medium. Notice how similar the patterns are to each other when the de Broglie wavelength of an electron beam equals the wavelength of the original x-rays.

**• De Broglie's hypothesis and Bohr's quantization condition**

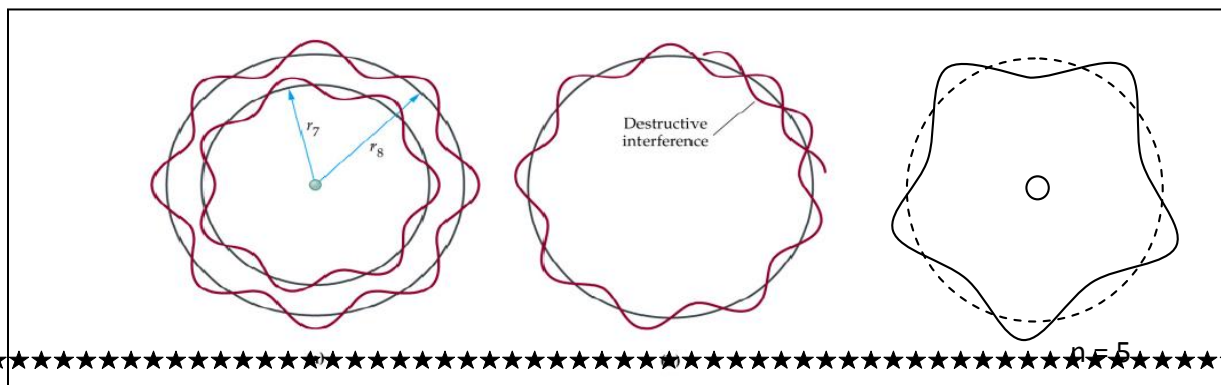

**De Broglie's hypothesis provides a nice explanation for Bohr's quantization**

**condition**  $L = n\hbar$ :

Assuming an electron possessing wave properties is subject to constructive and destructive interference. As will be shown this leads naturally to quantization of electron momentum and kinetic energy. In order to avoid destructive interference, the wave must be a standing wave, i.e. the electron's wavefunction must be single-valued, which in this application requires a circular boundary condition: the wavefunction must match at points separated by one

circumference :

$$n\lambda = 2\pi r \Rightarrow r = \frac{n\lambda}{2\pi}$$

Assuming that an integer number of wavelengths fit in one orbital circumference (the condition for a standing wave), we have

$$L = r \cdot p_{(dB)} = r \cdot \frac{h}{\lambda} = \frac{n\lambda}{2\pi} \cdot \frac{h}{\lambda} = n\hbar$$

It means that De Broglie derived one of the postulate Boher's model.

**Matter Wave Velocity ( De Broglie wave Velocity) :**

DeBroglie hypothesized that the wave aspect of a particle of matter should have an analogous wavelength,  $\lambda_{mw}$ , that should be :

$$\lambda = \frac{h}{mv} = \frac{h}{\text{particle momentum}}$$

This suggestion of DeBroglie was soon verified by Davison and Germer who obtained electron diffraction patterns and found that the observed wavelengths of the electron matter waves corresponded well with DeBroglie's formulation.

At that point one would think that the duality of matter, as of light,

was established and that extensive further investigation of matter waves would have resulted. But that was not the case and the reason was a fundamental problem that could not be overcome -- the matter wave frequency. If one reasons, analogously to the derivation of  $\lambda_{mw}$ ,

that the kinetic energy of :  $f_{wm} = \frac{E_k}{h} = \frac{\frac{1}{2}mv^2}{h}$

then the velocity of the matter wave is :  $v_{mw} = \lambda_{mw} \cdot f_{mw}$

$$= \left[ \frac{h}{m \cdot v} \right] \cdot \left[ \frac{\frac{1}{2} \cdot m \cdot v^2}{h} \right] = \frac{1}{2} \cdot v$$

This result states that **the matter wave moves** at one half the velocity of the particle. This is a strange result, in that there is nothing physically traveling at half the speed of the particles. From Quantum mechanics, It is found that this results agree with a plane wave, which not represent matter wave of a particle.

Using Einstein and de Broglie relations as  $E = \omega h = hf$  and  $p = h k = h / \lambda$  in terms of Planck's constant. In the nonrelativistic limit such that :

$$\gamma \equiv \frac{1}{\sqrt{1 - v^2 / c^2}} \approx 1$$

Another approach is to start from special relativity to get  $E = \gamma mc^2 \approx mc^2$  in which case :

$$v_{mw} = E / P = mc^2 / mv = (c/v) \cdot c$$

**This result means that  $v_{mw} > c$ , This is also a strange result, in that there is nothing physically traveling at more than the speed of light.**

From quantum view, new Information were carried with respect to the movement of matter wave of particles. This new information is a group velocity.  $v_g$  :

$$v_g = d\omega / dk = dE / dp .$$

Classically this expression becomes:

$$v_g \approx \frac{d}{dp} \left( \frac{p^2}{2m} \right) = \frac{p}{m} = v$$

which, in contrast to the phase velocity, is an intuitively sensible answer. In fact, it remains valid even for relativistic particles because :

$$v_g = \frac{d}{dp} \sqrt{m^2 c^4 + p^2 c^2} = \frac{c^2 p}{\sqrt{m^2 c^4 + p^2 c^2}} = \frac{c^2 p}{E} = \frac{c^2 \gamma m v}{\gamma m c^2} = v$$

which makes it even more satisfying. In particular, for a photon  $E = cp$  so that

$$v_g = \frac{d}{dp} (cp) = c .$$

For a photon, one also gets  $v_{mv} = E / p = c$ . The result is that for a highly relativistic particle,  $E$  is linear in  $p$  so that:  $dE / dp = E / p = v_{mv} = v_g$

**●Matter Waves for Macroscopic Objects**

We have seen that microscopic particles, such as electrons, display wave behavior. What about macroscopic objects? Do they also display wave features? They surely do. Although macro-scopic material particles display wave properties, the corresponding wavelengths are too small to detect; being very massive<sup>12</sup>, macroscopic objects have extremely small wavelengths. At the microscopic level, however, the waves associated with material particles are of the same size or exceed the size of the system. Microscopic particles therefore exhibit clearly discernible wave-like aspects.

The general rule is: whenever the de Broglie wavelength of an object is in the range of, or exceeds, its size, the wave nature of the object is detectable and hence cannot be neglected. But if its de Broglie wavelength is much too small compared to its size, the wave behavior of this object is undetectable. For a quantitative illustration of this general rule, let us calculate in the following example the wavelengths corresponding to two particles, one microscopic and the other macroscopic.

## 1-Particles versus Waves

In this section we are going to study the properties of particles and waves within the contexts of classical and quantum physics. The experimental setup to study these aspects is the *double-slit experiment*, which consists of a source  $S$  ( $S$  can be a source of material particles or of waves), a wall with two slits  $S_1$  and  $S_2$ , and a back screen equipped with counters that record whatever arrives at it from the slits.

### 1.1 Classical View of Particles and Waves

In classical physics, particles and waves are mutually exclusive; they exhibit completely different behaviors. While the full description of a particle requires only one parameter, the position vector  $\vec{r}(t)$ , the complete description of a wave requires two, the amplitude and the phase. For instance, three-dimensional plane waves can be described by wave functions  $\psi(\vec{r}, t)$ :

$$\psi(\vec{r}, t) = Ae^{i(\vec{k}\cdot\vec{r}-\omega t)} = Ae^{i\phi},$$

where  $A$  is the amplitude of the wave and  $\phi$  is its phase ( $\vec{k}$  is the wave vector and  $\omega$  is the angular frequency). We may recall the physical meaning of  $\Psi$  the intensity of the wave is given by :  $I = |\psi|^2$ .

#### (a) $S$ is a source of streams of bullets

Consider three different experiments as displayed in Figure 1.8, in which a source  $S$  fires a stream of bullets; the bullets are assumed to be indestructible and hence arrive on the screen in identical lumps. In the first experiment, only slit  $S_1$  is open; let  $I_1(y)$  be the corresponding intensity collected on the screen (the number of bullets arriving per second at a given point  $y$ ).

In the second experiment, let  $I_2(y)$  be the intensity collected on the screen when only  $S_2$  is open. In the third experiments, if  $S_1$  and  $S_2$  are both open, the total intensity collected on the screen behind the two slits must be equal to the sum of  $I_1$  and  $I_2$ :

$$I(y) = I_1(y) + I_2(y).$$

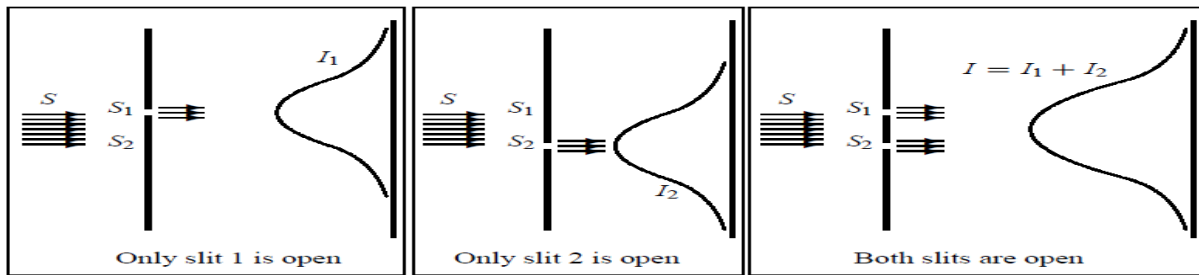

**Figure:** The double-slit experiment with *particles*:  $S$  is a source of *bullets*;  $I_1$  and  $I_2$  are the intensities recorded on the screen, respectively, when only  $S_1$  is open and then when only  $S_2$  is open. When both slits are open, the total intensity is  $I = I_1 + I_2$

**(b)  $S$  is a source of waves**

Now, as depicted in Figure 1.9,  $S$  is a source of waves (e.g., light or water waves). Let  $I_1$  be the intensity collected on the screen when only  $S_1$  is open and  $I_2$  be the intensity when only  $S_2$  is open. Recall that a wave is represented by a complex function  $\Psi_1$ , and its intensity is proportional to its amplitude (e.g., height of water or electric field) squared:  $I_1 = |\psi_1|^2$ ,  $I_2 = |\psi_2|^2$ .

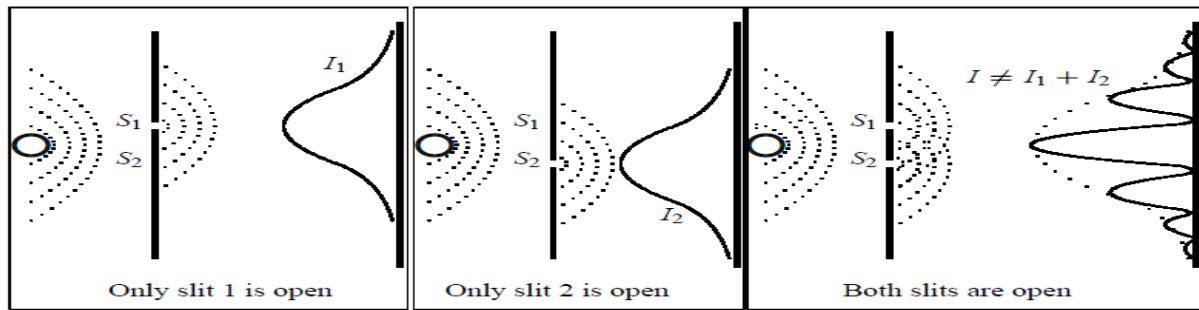

**Figure:** The double-slit experiment:  $S$  is a source of *waves*,  $I_1$  and  $I_2$  are the intensities recorded on the screen when only  $S_1$  is open, and then when only  $S_2$  is open, respectively. When both slits are open, the total intensity is no longer equal to the sum of  $I_1$  and  $I_2$ ; an *oscillating* term has to be added.

When both slits are open, the total intensity collected on the screen displays an *interference* pattern; hence it cannot be equal to the sum of  $I_1$  and  $I_2$ . The amplitudes, not the intensities, must add: the total amplitude  $\Psi$  is the sum of  $\Psi_1$  and  $\Psi_2$  ; hence the total intensity is given by:

$$\begin{aligned}
 I &= |\psi_1 + \psi_2|^2 = |\psi_1|^2 + |\psi_2|^2 + (\psi_1^* \psi_2 + \psi_2^* \psi_1) = I_1 + I_2 + 2\text{Re}(\psi_1^* \psi_2) \\
 &= I_1 + I_2 + 2\sqrt{I_1 I_2} \cos \delta,
 \end{aligned}$$

where  $\delta$  is the phase difference between  $\Psi_1$  and  $\Psi_2$  and  $2\sqrt{I_1 I_2} \cos \delta$  is an oscillating term, which is responsible for the interference pattern (Figure 1.9). So the resulting intensity distribution cannot be predicted from  $I_1$  or from  $I_2$  alone, for it depends on the phase  $\delta$ , which cannot be measured when only one slit is open ( $\delta$  can be calculated from the slits separation or from the observed intensities  $I_1, I_2$  and  $I$ ).

**Conclusion:** Classically, waves exhibit interference patterns, particles do not. When two noninteracting streams of particles combine in the same region of space, their intensities add; when waves combine, their amplitudes add but their intensities do not.

### 1.2 Quantum View of Particles and Waves

Let us now discuss the double-slit experiment with quantum material particles such as electrons. Figure 1.10 shows three different experiments where the source  $S$  shoots a stream of electrons,

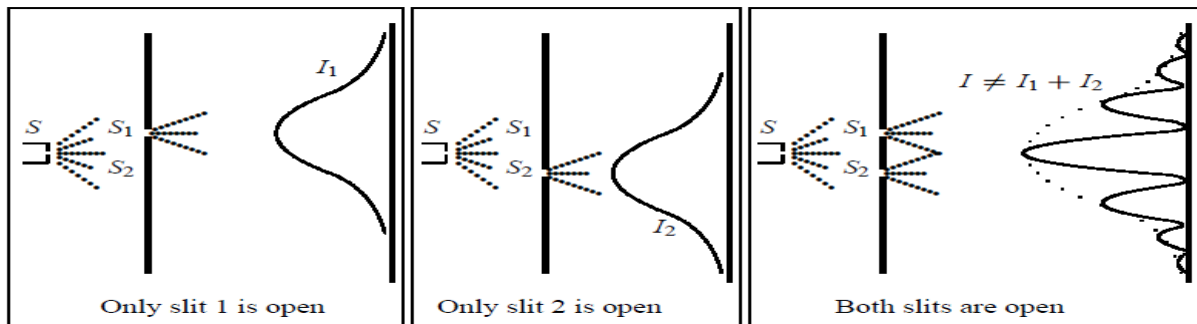

**Figure 1.10** The double-slit experiment:  $S$  is a source of *electrons*,  $I_1$  and  $I_2$  are the intensities recorded on the screen when only  $S_1$  is open, and then when only  $S_2$  is open, respectively. When both slits are open, the total intensity is equal to the sum of  $I_1, I_2$  and an *oscillating* term.

first with only  $S_1$  open, then with only  $S_2$  open, and finally with both slits open. In the first two cases, the distributions of the electrons on the screen are smooth; the sum of these distributions is also smooth, a bell-shaped curve like the one obtained for classical particles (Figure 1.8).

But when both slits are open, we see a rapid variation in the distribution, an *interference pattern*. So in spite of their discreteness, the electrons seem to interfere with themselves; this means that each electron seems to have gone through both slits at once! One might ask, if an electron cannot be split, how can



it appear to go through both slits at once? Note that this interference pattern has nothing to do with the intensity of the electron beam. In fact, experiments were carried out with beams so weak that the electrons were sent one at a time (i.e., each electron was sent only after the previous electron has reached the screen). In this case, if both slits were open and if we wait long enough so that sufficient impacts are collected on the screen, the interference pattern appears again.

The crucial question now is to find out the slit through which the electron went. To answer this query, an experiment can be performed to watch the electrons as they leave the slits. It consists of placing a strong light source behind the wall containing the slits, as shown in Figure 1.11. We place Geiger counters all over the screen so that whenever an electron reaches the screen we hear a click on the counter.

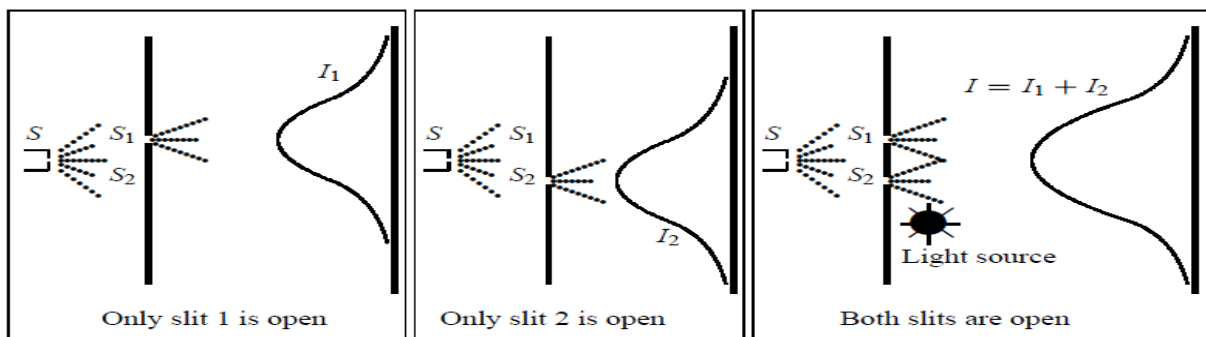

**Figure 1.11** The double-slit experiment:  $S$  is a source of *electrons*. A *light source* is placed behind the wall containing  $S_1$  and  $S_2$ . When both slits are open, the interference pattern is destroyed and the total intensity is  $I = I_1 + I_2$ .

Since electric charges scatter light, whenever an electron passes through either of the slits, on its way to the counter, it will scatter light to our eyes. So, whenever we hear a click on the counter, we see a flash near *either*  $S_1$  or  $S_2$  but *never near both at once*. After recording the various counts with both slits open, we find out that the distribution is similar to that of classical bullets in Figure 1.8: the interference pattern has disappeared! But if we turn off the light source, the interference pattern appears again.

From this experiment we conclude that the mere act of looking at the electrons immensely affects their distribution on the screen. Clearly, electrons are very delicate: their motion gets modified when one watches them. This is the very

quantum mechanical principle which states that *measurements interfere with the states of microscopic objects*. One might think of turning down the brightness (intensity) of the light source so that it is weak enough not to disturb the electrons.

We find that the light scattered from the electrons, as they pass by, does not get weaker; the same sized flash is seen, but only every once in a while. This means that, at low brightness levels, we miss some electrons: we hear the click from the counter but see no flash at all. At still lower brightness levels, we miss most of the electrons. We conclude, in this case, that some electrons went through the slits without being seen, because there were no photons around at the right moment to catch them. This process is important because it confirms that light has particle properties: light also arrives in lumps (photons) at the screen.

Two distribution profiles are compiled from this dim light source experiment, one corresponding to the electrons that were seen and the other to the electrons that were not seen (but heard on the counter). The first distribution contains no interference (i.e., it is similar to classical bullets); but the second distribution displays an interference pattern. This results from the fact that when the electrons are not seen, they display interference. When we do not see the electron, no photon has disturbed it but when we see it, a photon has disturbed it.

For the electrons that display interference, it is impossible to identify the slit that each electron had gone through. This experimental finding introduces a new fundamental concept: the microphysical world is *indeterministic*. Unlike classical physics, where we can follow accurately the particles along their trajectories, we cannot follow a microscopic particle along its motion nor can we determine its path. It is technically impossible to perform such detailed tracing of the particle's motion. Such results inspired Heisenberg to postulate the uncertainty principle, which states that *it is impossible to design an apparatus which allows us to determine the slit that the electron went through without disturbing the electron enough to destroy the interference pattern* (we shall return to this principle later).

The interference pattern obtained from the double-slit experiment indicates that electrons display both particle and wave properties. When electrons are observed or detected one by one, they behave like particles, but when they are detected after many measurements (distribution of the detected electrons), they behave like waves of wavelength  $\lambda = h/p$  and display an interference pattern.

## Solved Problems

**Example: 1** An electron and a photon have same wavelength. It  $p$  is the momentum of electron and  $E$  the energy of photon. The magnitude of  $p/ E$  in S.I. unit is

- (a)  $3.0 \times 10^8$       (b)  $3.33 \times 10^{-9}$       (c)  $9.1 \times 10^{-31}$       (d)  $6.64 \times 10^{-34}$

**Solution :** (b)  $\lambda = \frac{h}{p}$  (for electron)      or       $p = \frac{h}{\lambda}$       and       $E = \frac{hc}{\lambda}$  (for photon)

$$\therefore \frac{p}{E} = \frac{1}{c} = \frac{1}{3 \times 10^8 \text{ m/s}} = 3.33 \times 10^{-9} \text{ s/m}$$

**Example: 2** The energy of a photon is equal to the kinetic energy of a proton. The energy of the photon is  $E$ . Let  $\lambda_1$  be the de-Broglie wavelength of the proton and  $\lambda_2$  be the wavelength of the photon. The ratio  $\lambda_1/\lambda_2$  is proportional to

- (a)  $E^0$       (b)  $E^{1/2}$       (c)  $E^{-1}$       (d)  $E^{-2}$

**Solution :** (b) For photon  $\lambda_2 = \frac{hc}{E}$  ..... (i)      and      For proton  $\lambda_1 = \frac{h}{\sqrt{2mE}}$  .....(ii)

$$\text{Therefore } \frac{\lambda_1}{\lambda_2} = \frac{E^{1/2}}{\sqrt{2m} c} \Rightarrow \frac{\lambda_1}{\lambda_2} \propto E^{1/2} .$$

**Example: 3** The de-Broglie wavelength of an electron having  $80eV$  of energy is nearly ( $1eV = 1.6 \times 10^{-19} J$ , Mass of electron  $9 \times 10^{-31} kg$  and Plank's constant  $6.6 \times 10^{-34} J\text{-sec}$ )

- (a)  $140 \text{ \AA}$       (b)  $0.14 \text{ \AA}$       (c)  $14 \text{ \AA}$       (d)  $1.4 \text{ \AA}$

**Solution :** (d) By using  $\lambda = \frac{h}{\sqrt{2mE}} = \frac{12.27}{\sqrt{V}}$ . If energy is  $80 eV$  then accelerating potential

$$\text{difference will be } 80 \text{ V. So } \lambda = \frac{12.27}{\sqrt{80}} = 1.37 \approx 1.4 \text{ \AA} .$$

**Example: 4** The kinetic energy of electron and proton is  $10^{-32} J$ . Then the relation between their de-Broglie wavelengths is

- (a)  $\lambda_p < \lambda_e$       (b)  $\lambda_p > \lambda_e$       (c)  $\lambda_p = \lambda_e$       (d)  $\lambda_p = 2\lambda_e$

**Solution :** (a) By using  $\lambda = \frac{h}{\sqrt{2mE}}$ ,  $E = 10^{-32} J = \text{Constant}$  for both particles. Hence

$$\lambda \propto \frac{1}{\sqrt{m}} \quad \text{Since } m_p > m_e \text{ so } \lambda_p < \lambda_e .$$

**Example: 5** The energy of a proton and an  $\alpha$  particle is the same. Then the ratio of the de-Broglie wavelengths of the proton and the  $\alpha$  is

- (a) 1 : 2                      (b) 2 : 1                      (c) 1 : 4                      (d) 4 : 1

**Solution :** (b) By using  $\lambda = \frac{h}{\sqrt{2mE}} \Rightarrow \lambda \propto \frac{1}{\sqrt{m}}$  ( $E$  – same)  $\Rightarrow \frac{\lambda_{proton}}{\lambda_{\alpha-particle}} = \sqrt{\frac{m_{\alpha}}{m_p}} = \frac{2}{1}$ .

**Example: 6** The de-Broglie wavelength of a particle accelerated with 150 volt potential is  $10^{-10} m$ . If it is accelerated by 600 volts p.d., its wavelength will be

- (a) 0.25 Å                      (b) 0.5 Å                      (c) 1.5 Å                      (d) 2 Å

**Solution :** (b) By using  $\lambda \propto \frac{1}{\sqrt{V}} \Rightarrow \frac{\lambda_1}{\lambda_2} = \sqrt{\frac{V_2}{V_1}} \Rightarrow \frac{10^{-10}}{\lambda_2} = \sqrt{\frac{600}{150}} = 2 \Rightarrow \lambda_2 = 0.5 \text{ Å}$ .

**Example 7 :** The de-Broglie wavelength of an electron in an orbit of circumference  $2\pi r$  is

- (a)  $2\pi r$                       (b)  $\pi r$                       (c)  $1/2\pi r$                       (d)  $1/4\pi r$

**Solution :** (a) According to Bohr's theory  $mv r = n \frac{h}{2\pi} \Rightarrow 2\pi r = n \left( \frac{h}{mv} \right) = n\lambda$

**For  $n = 1$      $\lambda = 2\pi r$**

**Example: 8** The number of photons of wavelength 540 nm emitted per second by an electric bulb of power 100W is (taking  $h = 6 \times 10^{-34} J\text{-sec}$ )

- (a) 100                      (b) 1000                      (c)  $3 \times 10^{20}$                       (d)  $3 \times 10^{18}$

**Solution :** (c) By using  $n = \frac{P\lambda}{hc} = \frac{100 \times 540 \times 10^{-9}}{6.6 \times 10^{-34} \times 3 \times 10^8} = 3 \times 10^{20}$

**Example: 9** A steel ball of mass 1kg is moving with a velocity 1 m/s. Then its de-Broglie waves length is equal to

- (a)  $h$                       (b)  $h/2$                       (c) Zero                      (d)  $1/h$

**Solution :** (a) By using  $\lambda = \frac{h}{mv} \Rightarrow \lambda = \frac{h}{1 \times 1} = h$ .

**Example: 10** The de-Broglie wavelength associated with a hydrogen atom moving with a thermal velocity of 3 km/s will be

- (a) 1 Å                      (b) 0.66 Å                      (c) 6.6 Å                      (d) 66 Å

**Solution :** (b) By using  $\lambda = \frac{h}{mv_{rms}} \Rightarrow \lambda = \frac{6.6 \times 10^{-34}}{2 \times 1.67 \times 10^{-27} \times 3 \times 10^3} = 0.66 \text{ Å}$

**Example: 11** When the momentum of a proton is changed by an amount  $P_0$ , the corresponding change in the de-Broglie wavelength is found to be 0.25%. Then, the original momentum of the proton was

- (a)  $p_0$                       (b)  $100 p_0$                       (c)  $400 p_0$                       (d)  $4 p_0$

$$\text{Solution : (c) } \lambda \propto \frac{1}{p} \Rightarrow \frac{\Delta p}{p} = -\frac{\Delta \lambda}{\lambda} \Rightarrow \left| \frac{\Delta p}{p} \right| = \left| \frac{\Delta \lambda}{\lambda} \right| \Rightarrow \frac{p_0}{p} = \frac{0.25}{100} = \frac{1}{400} \Rightarrow p = 400 p_0$$

**Example: 12** If the electron has same momentum as that of a photon of wavelength 5200Å, then the velocity of electron in m/sec is given by

- (a)  $10^3$     (b)  $1.4 \times 10^3$     (c)  $7 \times 10^{-5}$     (d)  $7.2 \times 10^6$

$$\text{Solution : (b) } \lambda = \frac{h}{mv} \Rightarrow v = \frac{h}{m\lambda} = \frac{6.6 \times 10^{-34}}{9.1 \times 10^{-31} \times 5200 \times 10^{-10}} \Rightarrow v = 1.4 \times 10^3 \text{ m/s.}$$

**Example: 13** The de-Broglie wavelength of a neutron at 27°C is  $\lambda$ . What will be its wavelength at 927°C

- (a)  $\lambda / 2$     (b)  $\lambda / 3$     (c)  $\lambda / 4$     (d)  $\lambda / 9$

$$\text{Solution : (a) } \lambda_{neutron} \propto \frac{1}{\sqrt{T}} \Rightarrow \frac{\lambda_1}{\lambda_2} = \sqrt{\frac{T_2}{T_1}} \Rightarrow \frac{\lambda}{\lambda_2} = \sqrt{\frac{(273 + 927)}{(273 + 27)}} = \sqrt{\frac{1200}{300}} = 2 \Rightarrow \lambda_2 = \frac{\lambda}{2}.$$

**Example: 14** The de-Broglie wavelength of a vehicle is  $\lambda$ . Its load is changed such that its velocity and energy both are doubled. Its new wavelength will be

- (a)  $\lambda$     (b)  $\frac{\lambda}{2}$     (c)  $\frac{\lambda}{4}$     (d)  $2\lambda$

$$\text{Solution : (a) } \lambda = \frac{h}{mv} \text{ and } E = \frac{1}{2}mv^2 \Rightarrow \lambda = \frac{hv}{2E} \text{ when } v \text{ and } E \text{ both are doubled, } \lambda \text{ remains unchanged i.e. } \lambda' = \lambda.$$

## Heisenberg Uncertainty Principle

According to Heisenberg's uncertainty principle, it is impossible to measure simultaneously both the position and the momentum of the particle.

Let  $\Delta x$  and  $\Delta p$  be the uncertainty in the simultaneous measurement of the position and momentum of the particle, then  $\Delta x \Delta p = \hbar$

where  $\hbar = \frac{h}{2\pi}$  and  $h = 6.63 \times 10^{-34}$  J-s is the Planck's constant.

If  $\Delta x = 0$  then  $\Delta p = \infty$  and if  $\Delta p = 0$  then  $\Delta x = \infty$  i.e., if we are able to measure the exact position of the particle (say an electron) then the uncertainty in the measurement of the linear momentum of the particle is infinite.

Similarly, if we are able to measure the exact linear momentum of the particle i.e.,  $\Delta p = 0$ , then we can not measure the exact position of the particle at that time.

In its original form, Heisenberg's uncertainty principle states that: *If the x-component of the momentum of a particle is measured with an uncertainty  $\Delta p_x$ , then its x-position cannot, at the same time, be measured more accurately than  $\Delta x \geq \frac{h}{2\Delta p_x}$ .* The three-dimensional form of the uncertainty relations for position and momentum can be written as follows:

$$\Delta x \Delta p_x \geq \frac{\hbar}{2}, \quad \Delta y \Delta p_y \geq \frac{\hbar}{2}, \quad \Delta z \Delta p_z \geq \frac{\hbar}{2}.$$

### Derivation Of Heisenberg Uncertainty Principle

Consider the electron diffraction by a single slit. We know that the position of the first minimum is given by

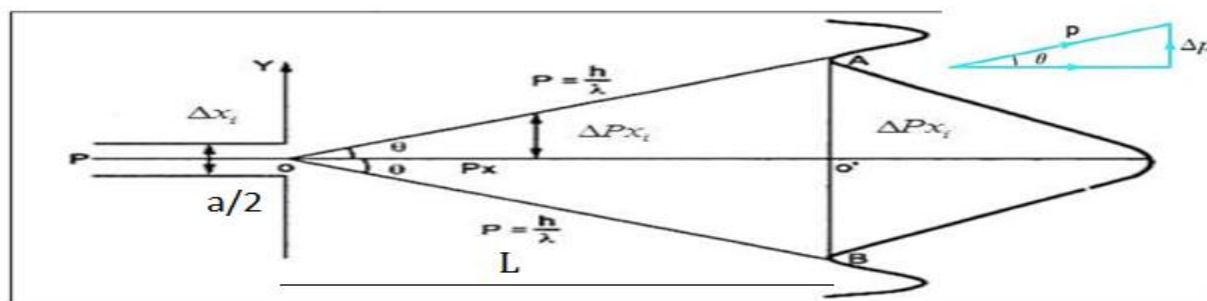

$$\begin{cases} \sin\theta = \frac{\lambda}{a} = \frac{\lambda}{\Delta X} \Rightarrow \Delta X = \frac{\lambda}{\sin\theta} \\ \Delta p_x = p \sin\theta \end{cases}$$

$$\Rightarrow \Delta X \cdot \Delta p_x \approx h$$

A finer slit would locate the particle more precisely but lead to a wider diffraction pattern that is, to a greater uncertainty in the transverse momentum.

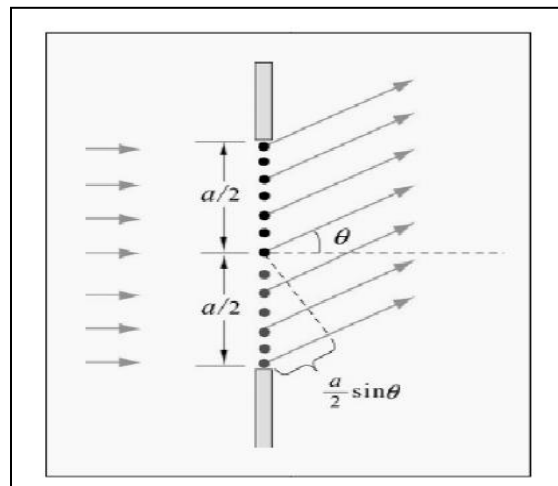

The width of the central maximum (x), is given by

$$x = 2 \lambda L / a.$$

$$\Delta x * \Delta p = a/2 * x_1 h / \lambda L = a/2 * \lambda L/a * h/\lambda L = h/2$$

$$\Delta \lambda \Delta x > \lambda^2 \equiv \Delta k \Delta x > 2\pi$$

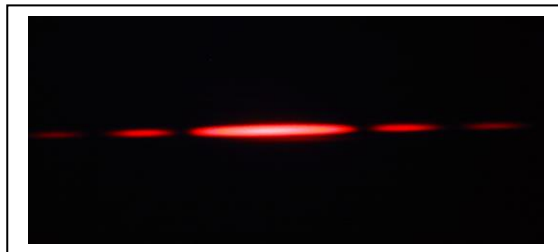

### The uncertainty relationships for classical waves?

- As discussed earlier, due to its nature, a wave packet must obey the uncertainty relationships for classical waves (which are derived mathematically with some approximations).

$$\Delta \lambda \Delta x > \lambda^2 \equiv \Delta k \Delta x > 2\pi$$

- However a more rigorous mathematical treatment (without the approximation) gives the exact relations

$$\Delta \lambda \Delta x \geq \frac{\lambda^2}{4\pi} \equiv \Delta k \Delta x \geq 1/2$$

$$\Delta \nu \Delta t \geq \frac{1}{4\pi}$$

FIGURE 3.12 (a) A narrow de Broglie wave group. The position of the particle can be precisely determined, but the wavelength (and hence the particle's momentum) cannot be established because there are not enough waves to measure accurately. (b) A wide wave group. Now the wavelength can be precisely determined but not the position of the particle.

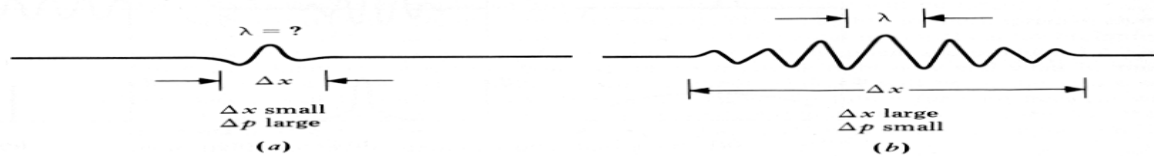

$\Delta x$  requires a large range of wave number; that is,  $\Delta k$  is large. Conversely, a



small range of wave number cannot produce a wave packet localised within a small distance.

- A narrow wave packet (small  $\Delta x$ ) corresponds to a large spread of wavelengths (large  $\Delta k$ ).
- A wide wave packet (large  $\Delta x$ ) corresponds to a small spread of wavelengths (small  $\Delta k$ ).

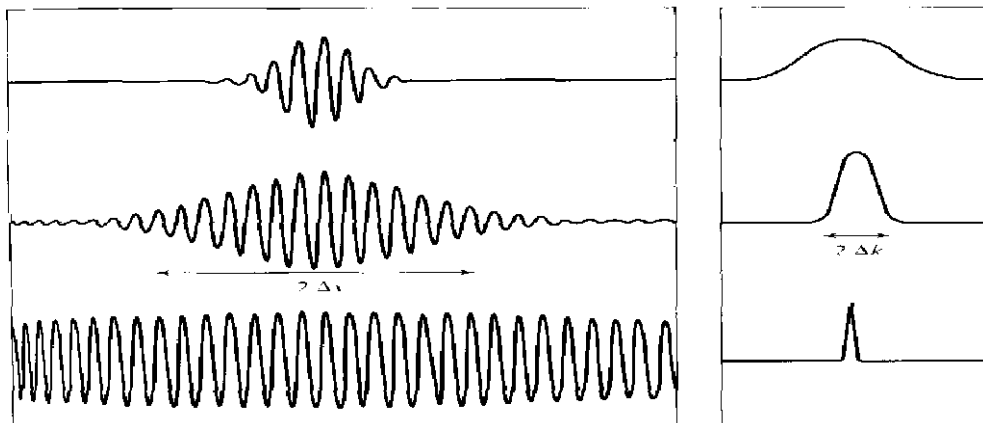

- For matter waves, for which their momentum and wavelength are related by  $p = h/\lambda$ , the uncertainty relationship of the classical wave

$$\Delta \lambda \Delta x \geq \frac{\lambda^2}{4\pi} \equiv \Delta k \Delta x \geq 1/2$$
 is translated into 
$$\Delta p_x \Delta x \geq \frac{\hbar}{2}$$
 where  $\hbar = h/2\pi$

Prove this relation yourselves (from  $p = h/\lambda, \Delta p/p = \Delta \lambda/\lambda$ )

**Heisenberg uncertainty relations**

$$\Delta p_x \Delta x \geq \frac{\hbar}{2} \qquad \Delta E \Delta t \geq \frac{\hbar}{2}$$

The product of the uncertainty in momentum (energy) and in position (time) is at least as large as Planck's constant.

- What  $\Delta p_x \Delta x \geq \frac{\hbar}{2}$  means :

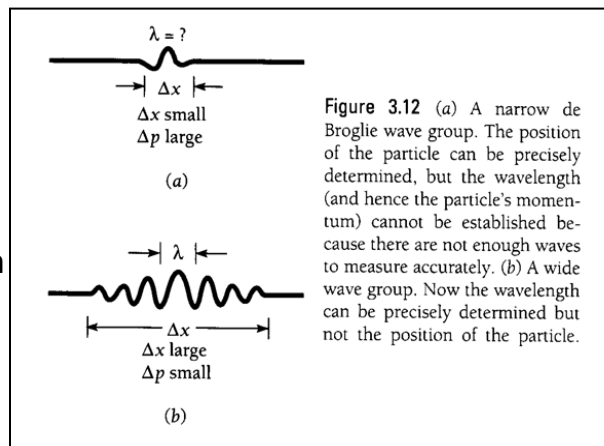

- It sets the intrinsic lowest possible limits on the uncertainties in knowing the values of  $p_x$  and  $x$ , no matter how good an experiment is made
- It is impossible to specify simultaneously and with infinite precision the linear momentum and the corresponding position of a particle.
- It is impossible for the product  $\Delta x \Delta p_x$  to be less than  $h/4\pi$

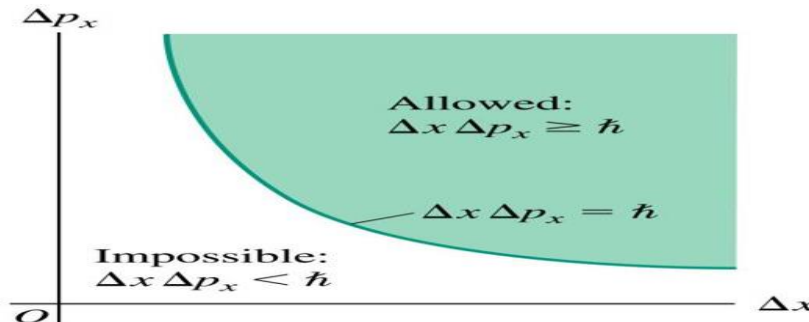

Copyright © 2004 Pearson Education, Inc., publishing as Addison Wesley.  
**What  $\Delta E \Delta t \geq \frac{\hbar}{2}$  means : Uncertainty principle for energy**

- The energy of a system also has inherent uncertainty,  $DE$
- $DE$  is dependent on the *time interval*  $Dt$  during which the system remains in the given states.
- If a system is known to exist in a state of energy  $E$  over a limited period  $Dt$ , then this energy is uncertain by at least an amount  $h/(4\pi Dt)$ . This corresponds to the ‘spread’ in energy of that state (see next page)
- Therefore, the energy of an object or system can be measured with infinite precision ( $DE=0$ ) only if the object of system exists for an infinite time ( $Dt \rightarrow \infty$ )

- A system that remains in a metastable state for a very long time (large  $Dt$ ) can have a very well-defined energy (small  $DE$ ), but if remain in a state for only a short time (small  $Dt$ ), the uncertainty in energy must be correspondingly greater (large  $DE$ ).

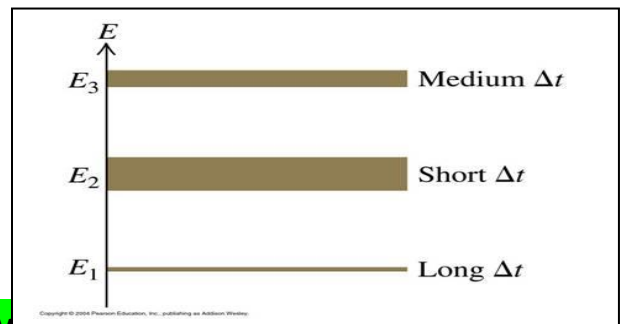

**Physical Interpretation of de Broglie Waves**

Let's go back to de Broglie equation. Note that the de Broglie wavelength depends on two things: (1) mass and (2) velocity.

### • Mass Affects

$$\lambda = \frac{h}{mv} \longrightarrow \left\{ \begin{array}{l} \text{large masses} \Rightarrow \text{small de Broglie waves} \longrightarrow \lambda = \frac{h}{m v} \\ \text{small masses} \Rightarrow \text{large de Broglie waves} \longrightarrow \lambda = \frac{h}{m v} \end{array} \right.$$

“Big objects” like a tennis ball or your brave instructor have masses considerably larger than the mass of an atom or electron ( $m_{\text{tennis ball}} \approx 1 \text{ kg} \gg m_{\text{electron}} \approx 10^{-31} \text{ kg}$ ). One can use the de Broglie equation to estimate the matter wavelength of a tennis ball moving at a speed of 1 m/s:

$$\lambda = \frac{h}{mv} \approx \frac{10^{-34}}{1.1} \approx 10^{-34} \text{ m}$$

As you can see, this is a very tiny, tiny number and we will never notice the wavelike aspects of this tennis ball, though in principle, according to quantum physics they exist. Why? Planck’s constant is so small and ordinary masses are very large compared to atomic masses. On the other hand, if we want to see wavelike aspects of matter, two things must happen:

- we need very, very small masses in order to make the de Broglie wavelength as large as possible.
- if the de Broglie wavelength becomes comparable to the size of the object then the wavelike aspects will become very dramatic for those objects.

For example, for an electron in orbit in a typical atom, you’ll find the wavelength associated with that electron is roughly comparable to the size of the atom itself. So if de Broglie hypothesis is correct, we ought to notice wavelike aspects at the subatomic world but not in the macroscopic world. That is exactly what is observed in the **Quantum Corral**.

### Velocity Affects

$$\lambda = \frac{h}{m v} \longrightarrow \left\{ \begin{array}{l} \text{large velocities} \Rightarrow \text{small de Broglie waves} \longrightarrow \lambda = \frac{h}{m V} \\ \text{small velocities} \Rightarrow \text{large de Broglie waves} \longrightarrow \lambda = \frac{h}{m v} \end{array} \right.$$

Another way to make the de Broglie wavelength really large (even if the object had a substantial mass) is to reduce the velocity of the particle to a very small value. For example, if I could bring this tennis ball truly to rest then the de Broglie wavelength of the tennis ball would be comparable to the size of the tennis ball and the wavelike aspects of the ball would be apparent to you and me (that's crazy!). However, because the ball is composed of zillions and zillions of atoms that are bouncing around hitting the sides, I can't bring it to rest and therefore, the de Broglie wavelength is too small. But if I could bring it to rest I could see quantum effects even in macroscopic size systems.

**Conjugate variables (Conjugate observables):**

- $\{p_x, x\}, \{E, t\}$  are called *conjugate variables*
- The conjugate variables cannot in principle be measured (or known) to infinite precision simultaneously



# Chapter (3) **Special Relativity**

## Chapter (3)

### Special Theory of Relativity

#### Newtonian (Classical) Relativity

##### Assumption

- It is assumed that Newton's laws of motion must be measured with respect to (relative to) some reference frame.
- A reference frame is called an inertial frame if Newton laws are valid in that frame.
- Such a frame is established when a body, not subjected to net external forces, is observed to move in rectilinear motion at constant velocity
- If Newton's laws are valid in one reference frame, then they are also valid in another reference frame moving at a uniform velocity relative to the first system.
- This is referred to as the Newtonian principle of relativity or Galilean invariance.

##### Inertial Frames $K$ and $K'$

- $K$  is at rest and  $K'$  is moving with velocity
- Axes are parallel
- $K$  and  $K'$  are said to be  
INERTIAL COORDINATE SYSTEMS

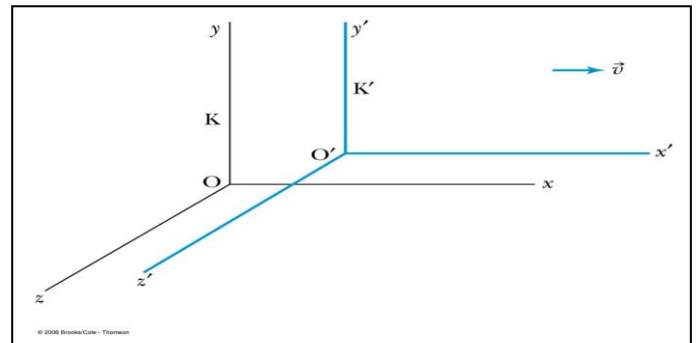

##### The Galilean Transformation

For a point  $P$

- In system  $K$ :  $P = (x, y, z, t)$
- In system  $K'$ :  $P = (x', y', z', t')$

##### Conditions of the Galilean Transformation

- Parallel axes
- $K'$  has a constant relative velocity in the  $x$ -direction with respect to  $K$

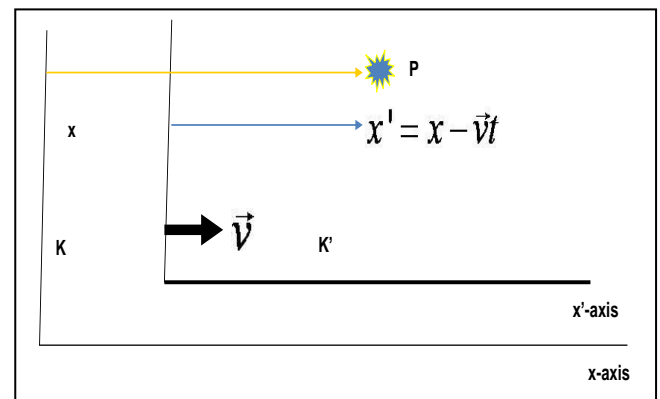

$$x' = x - \vec{v}t$$

$$y' = y$$

$$z' = z$$

$$\underline{t' = t}$$

●Time ( $t$ ) for all observers is a Fundamental invariant, i.e., the same for all inertial observers

### The Inverse Relations

Step 1. Replace  $\vec{v}$  with  $-\vec{v}$

Step 2. Replace “primed” quantities with “unprimed” and “unprimed” with “primed.”

$$x = x' + \vec{v}t'$$

$$y = y'$$

$$z = z'$$

$$t = t'$$

### The Transition to Modern Relativity

- Although Newton’s laws of motion had the same form under the Galilean transformation, Maxwell’s equations did not.
- In 1905, Albert Einstein proposed a fundamental connection between space and time and that Newton’s laws are only an approximation.

#### ٢.1: The Need for Ether

●The wave nature of light suggested that there existed a propagation medium called the *luminiferous ether* or just ether.

- Ether had to have such a low density that the planets could move through it without loss of energy
- It also had to have an elasticity to support the high velocity of light waves

## Maxwell's Equations

- In Maxwell's theory the speed of light, in terms of the permeability and permittivity of free space, was given by

$$v = c = 1 / \sqrt{\mu_0 \epsilon_0}$$

- Thus the velocity of light between moving systems must be a constant

## An Absolute Reference System

- Ether was proposed as an absolute reference system in which the speed of light was this constant and from which other measurements could be made.
- The Michelson-Morley experiment was an attempt to show the existence of ether.

## 2.2: The Michelson-Morley Experiment

- Albert Michelson (1852–1931) was the first U.S. citizen to receive the Nobel Prize for Physics (1907), and built an extremely precise device called an *interferometer* to measure the minute phase difference between two light waves traveling in mutually orthogonal directions.

## The Michelson Interferometer

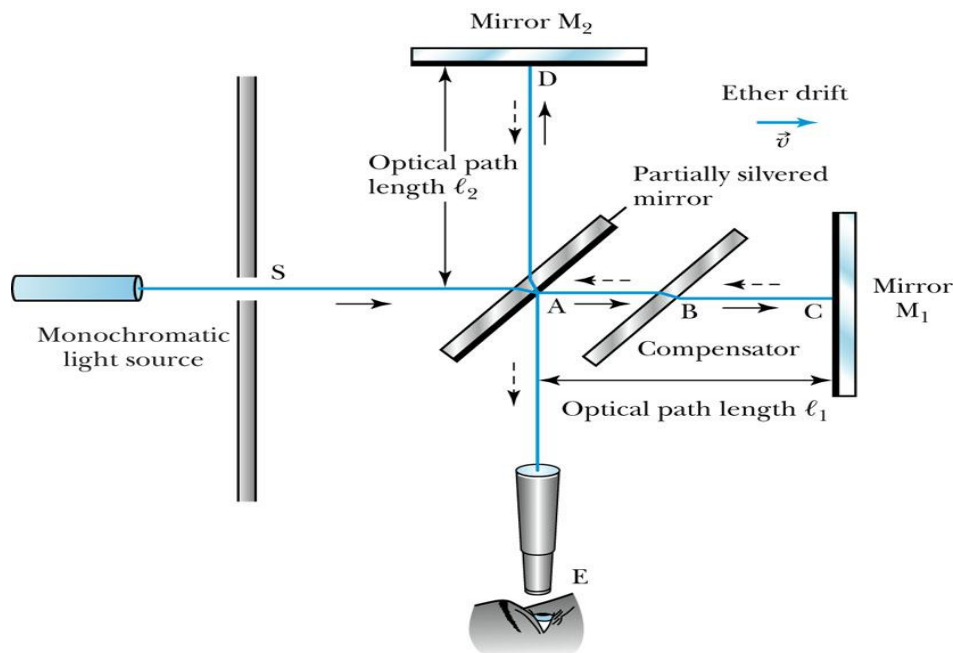



1. AC is parallel to the motion of the Earth inducing an “ether wind”
2. Light from source S is split by mirror A and travels to mirrors C and D in mutually perpendicular directions
3. After reflection the beams recombine at A slightly out of phase due to the “ether wind” as viewed by telescope E.

**Typical interferometer fringe pattern expected when the system is rotated by 90°**

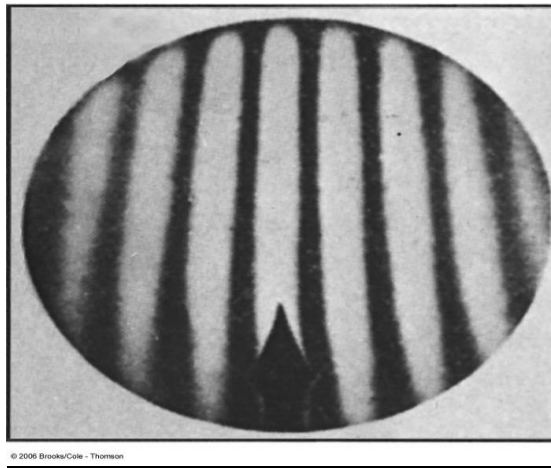

**The Analysis**

**Assuming the Galilean Transformation**

Time  $t_1$  from A to C and back:

$$t_1 = \frac{l_1}{c+v} + \frac{l_1}{c-v} = \frac{2cl_1}{c^2 - v^2} = \frac{2l_1}{c} \left( \frac{1}{1 - v^2/c^2} \right)$$

Time  $t_2$  from A to D and back:

$$t_2 = \frac{2l_2}{\sqrt{c^2 - v^2}} = \frac{2l_2}{c} = \frac{1}{\sqrt{1 - v^2/c^2}}$$

So that the change in time is:

$$\Delta t = t_2 - t_1 = \frac{2}{c} \left( \frac{l_2}{\sqrt{1 - v^2/c^2}} - \frac{l_1}{\sqrt{1 - v^2/c^2}} \right)$$

Upon rotating the apparatus, the optical path lengths  $\ell_1$  and  $\ell_2$  are interchanged producing a different change in time: (note the change in denominators)

$$\Delta t' = t'_2 - t'_1 = \frac{2}{c} \left( \frac{\ell_2}{1 - v^2/c^2} - \frac{\ell_1}{\sqrt{1 - v^2/c^2}} \right)$$

Thus a time difference between rotations is given by:

$$\Delta t' - \Delta t = \frac{2}{c} \left( \frac{\ell_1 + \ell_2}{1 - v^2/c^2} - \frac{\ell_1 + \ell_2}{1 - v^2/c^2} \right)$$

and upon a binomial expansion, assuming  $v/c \ll 1$ , this reduces to

$$\Delta t' - \Delta t \approx v^2(\ell_1 + \ell_2)/c^3$$

### Results

- Using the Earth's orbital speed as:  $V = 3 \times 10^4$  m/s
- together with  $\ell_1 \approx \ell_2 = 1.2$  m
- So that the time difference becomes  $\Delta t' - \Delta t \approx v^2(\ell_1 + \ell_2)/c^3 = 8 \times 10^{-17}$  s
- Although a very small number, it was within the experimental range of measurement for light waves.

### Michelson's Conclusion

- Michelson noted that he should be able to detect a phase shift of light due to the time difference between path lengths but found none.
- He thus concluded that the hypothesis of the stationary ether must be incorrect.
- After several repeats and refinements with assistance from Edward Morley (1893-1923), again *a null result*.
- ***Thus, ether does not seem to exist!***

### Possible Explanations

- Many explanations were proposed but the most popular was the *ether drag* hypothesis.

- ❑ This hypothesis suggested that the Earth somehow “dragged” the ether along as it rotates on its axis and revolves about the sun.
- ❑ This was contradicted by *stellar aberration* wherein telescopes had to be tilted to observe starlight due to the Earth’s motion. If ether was dragged along, this tilting would not exist.

### **The Lorentz-FitzGerald Contraction**

●Another hypothesis proposed independently by both H. A. Lorentz and G. F. FitzGerald suggested that the length  $\ell_1$ , in the direction of the motion was *contracted* by a factor of

$$\sqrt{1 - v^2 / c^2}$$

...thus making the path lengths equal to account for the zero phase shift.

- ❑ This, however, was an ad hoc assumption that could not be experimentally tested.

### **3.3: Einstein’s Postulates**

- Albert Einstein (1879–1955) was only two years old when Michelson reported his first null measurement for the existence of the ether.
- At the age of 16 Einstein began thinking about the form of Maxwell’s equations in moving inertial systems.
- In 1905, at the age of 26, he published his startling proposal about the principle of relativity, which he believed to be fundamental

#### **Einstein’s Two Postulates**

With the belief that Maxwell’s equations must be valid in all inertial frames, Einstein proposes the following postulates:

- 1) **The principle of relativity:** The laws of physics are the same in all inertial systems. There is no way to detect absolute motion, and no preferred inertial system exists.
- 2) **The constancy of the speed of light:** Observers in all inertial systems measure the same value for the speed of light in a vacuum.

**Re-evaluation of Time**

- In Newtonian physics we previously assumed that  $t = t'$ 
  - Thus with “synchronized” clocks, events in  $K$  and  $K'$  can be considered simultaneous
- Einstein realized that each system must have its own observers with their own clocks and meter sticks
  - Thus events considered simultaneous in  $K$  may not be in  $K'$

**The Lorentz Transformations**

The special set of linear transformations that:

- 1- preserve the constancy of the speed of light ( $c$ ) between inertial observers; and,
- 2- account for the problem of simultaneity between these observers known as the Lorentz transformation equations

**Lorentz Transformation Equations**

$$x' = \frac{x - vt}{\sqrt{1 - v^2/c^2}} \quad y' = y \quad z' = z \quad t' = \frac{t - (vx/c^2)}{\sqrt{1 - v^2/c^2}}$$

A more symmetric form:

$$\beta = \frac{v}{c}$$

$$\gamma = \frac{1}{\sqrt{1 - v^2/c^2}}$$

$$x' = \gamma(x - \beta ct)$$

$$y' = y$$

$$z' = z$$

$$t' = \gamma(t - \beta x/c)$$

**properties of  $\gamma$** 

Recall  $\beta = v/c < 1$  for all observers.

- 1)  $\gamma \geq 1$  equals 1 only when  $v = 0$ .
- 2) Graph of  $\beta$ : (note  $v \neq c$ )

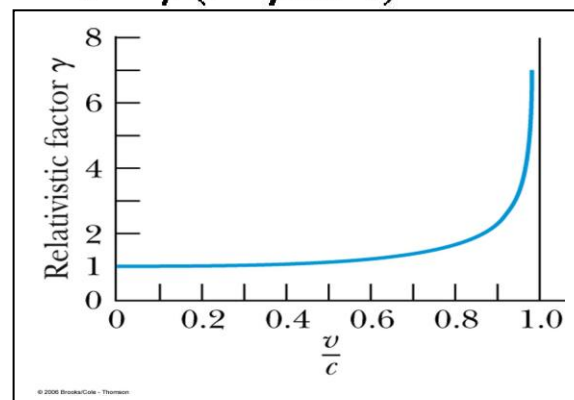

**Derivation :**

- Use the fixed system K and the moving system K'
- At  $t = 0$  the origins and axes of both systems are coincident with system K' moving to the right along the x axis.
- A flashbulb goes off at the origins when  $t = 0$ .
- According to postulate 2, the speed of light will be  $c$  in both systems and the wavefronts observed in both systems must be spherical.

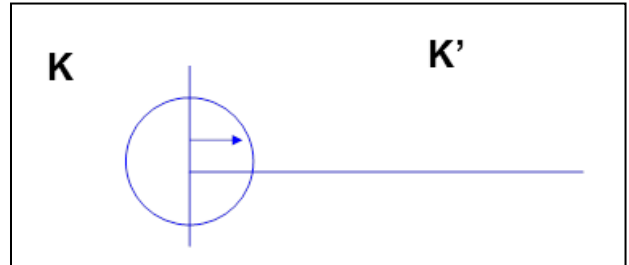

Spherical wavefronts in K:

$$x^2 + y^2 + z^2 = c^2 t^2$$

Spherical wavefronts in K':

$$x'^2 + y'^2 + z'^2 = c^2 t'^2$$

Note: these are not preserved in the classical transformations with

$$x' = x - vt$$

$$y' = y$$

$$z' = z$$

$$t = t'$$

**Derivation**

- 1) Let  $x' = \gamma (x - vt)$  so that  $x = \gamma' (x' + vt')$
- 2) By Einstein's first postulate:  $\gamma = \gamma'$
- 3) The wavefront along the  $x, x'$ - axis must satisfy:

$$x = ct \text{ and } x' = ct'$$

- 4) Thus  $ct' = \gamma (ct - vt)$  and  $ct = \gamma' (ct' + vt')$

- 5) Solving the first one above for  $t'$  and substituting into the second...

Gives the following result:

$$t' = \gamma^2 t' \left(1 - \frac{v}{c}\right) \left(1 + \frac{v}{c}\right)$$

from which we derive:

$$\gamma^2 = \frac{1}{1 - v^2/c^2}$$

Finding a Transformation for  $t'$

1) Recalling  $x' = \gamma (x - vt)$  substitute into  $x = \gamma' (x' + vt')$  and solving for  $t'$  we obtain:

$$t' = \frac{x}{\gamma v} (1 - \gamma^2) + \gamma t$$

which may be written in terms of  $\beta (= v/c)$ :

$$t' = \frac{t - (vx/c^2)}{\sqrt{1 - \beta^2}}$$

Thus the complete Lorentz Transformation

$$\begin{aligned} x' &= \frac{x - vt}{\sqrt{1 - \beta^2}} \\ y' &= y \\ z' &= z \\ t' &= \frac{t - (vx/c^2)}{\sqrt{1 - \beta^2}} \end{aligned}$$

$$\begin{aligned} x &= \frac{x' + vt'}{\sqrt{1 - \beta^2}} \\ y &= y' \\ z &= z' \\ t &= \frac{t' + \frac{vx'}{c^2}}{\sqrt{1 - \beta^2}} \end{aligned}$$

**Remarks**

- 1) If  $v \ll c$ , i.e.,  $\beta \approx 0$  and  $\gamma \approx 1$ , we see these equations reduce to the familiar Galilean transformation.
- 2) Space and time are now not separated.
- 3) For non-imaginary transformations, the frame velocity cannot exceed  $c$ .

**2.5: Time Dilation and Length Contraction**

Consequences of the Lorentz Transformation:

● **Time Dilation:**

Clocks in  $K'$  run slow with respect to stationary clocks in  $K$ .

● **Length Contraction:**

Lengths in  $K'$  are contracted with respect to the same lengths stationary in  $K$ .

**Time Dilation**

To understand *time dilation* the idea of **proper time** must be understood:

- The term **proper time**,  $T_0$ , is the time difference between two events occurring at the same position in a system as measured by a clock at that position.

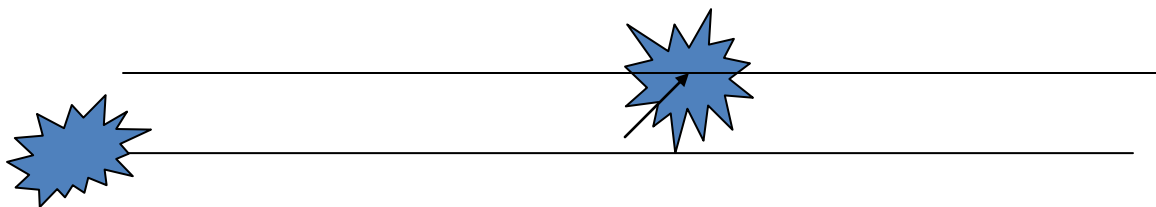

Frank’s clock is at the same position in system K when the sparkler is lit in (a) and when it goes out in (b). Mary, in the moving system K’, is beside the sparkler at (a). Melinda then moves into the position where and when the sparkler extinguishes at (b). Thus, Melinda, at the new position, measures the time in system K’ when the sparkler goes out in (b)

**According to Mary and Melinda**

●Mary and Melinda measure the two times for the sparkler to be lit and to go out in system K’ as times  $t'_1$  and  $t'_2$  so that by the Lorentz transformation:

$$t'_2 - t'_1 = \frac{(t_2 - t_1) - (v/c^2)(x_2 - x_1)}{\sqrt{1 - v^2/c^2}}$$

• Note here that Frank records  $x - x_1 = 0$  in K with a proper time:

$$T_0 = t_2 - t_1 \text{ or}$$

$$T' = \frac{T_0}{\sqrt{1 - v^2/c^2}} = \gamma T_0$$

with  $T' = t'_2 - t'_1$

**Time Dilation**

- 1-  $T' > T_0$  or the time measured between two events at *different positions* is greater than the time between the same events at *one position: time dilation*.
- 2) The events do not occur at the same space and time coordinates in the two system
- 3) System K requires 1 clock and K’ requires 2 clocks

**Length Contraction**

To understand *length contraction* the idea of proper length must be understood:

- Let an observer in each system K and K’ have a meter stick at rest in their own system such that each measure the same length at rest.
- The length as measured at rest is called the proper length

**What Frank and Mary see...**

Each observer lays the stick down along his or her respective  $x$  axis, putting the left end at  $x_\ell$  (or  $x'_\ell$ ) and the right end at  $x_r$  (or  $x'_r$ ).

- Thus, in system  $K$ , Frank measures his stick to be:  $L_0 = x_r - x_\ell$
- Similarly, in system  $K'$ , Mary measures her stick at rest to be:  $L'_0 = x'_r - x'_\ell$

**What Frank and Mary measure**

- Frank in his rest frame measures the moving length in Mary's frame moving with velocity.
- Thus using the Lorentz transformations Frank measures the length of the stick in  $K'$  as:

$$x'_r - x'_\ell = \frac{(x_r - x_\ell) - v(t_r - t_\ell)}{\sqrt{1 - v^2/c^2}}$$

Where both ends of the stick must be measured simultaneously, i.e,  $t_r = t_\ell$

Here Mary's proper length is  $L'_0 = x'_r - x'_\ell$  and Frank's measured length is

$$L = x_r - x_\ell$$

**Frank's measurement**

So Frank measures the moving length as  $L$  given by

$$L'_0 = \frac{L}{\sqrt{1 - v^2/c^2}} = \gamma L$$

but since both Mary and Frank in their respective frames measure  $L'_0 = L_0$

$$L = L_0 \sqrt{1 - v^2/c^2} = \frac{L_0}{\gamma}$$

and  $L_0 > L$ , i.e. the moving stick shrinks.

**3.6: Addition of Velocities**

Taking differentials of the Lorentz transformation, relative velocities may be calculated:

$$dx = \gamma(dx' + v dt')$$

$$dy = dy'$$

$$dz = dz'$$

$$dt = \gamma[dt' + (v/c^2) dx']$$



So that... defining velocities as:  $u_x = dx/dt$ ,  $u_y = dy/dt$ ,  $u'_x = dx'/dt'$ , etc. it is easily shown that:

$$u_x = \frac{dx}{dt} = \frac{\gamma(dx' + v dt')}{\gamma[dt' + (v/c^2) dx']} = \frac{u'_x + v}{1 + (v/c^2)u'_x}$$

With similar relations for  $u_y$  and  $u_z$ :

$$u_y = \frac{u'_y}{\gamma[1 + (v/c^2)u'_x]} \quad u_z = \frac{u'_z}{\gamma[1 + (v/c^2)u'_x]}$$

### **The Lorentz Velocity Transformations**

In addition to the previous relations, the Lorentz velocity transformations for  $u'_x$ ,  $u'_y$ , and  $u'_z$  can be obtained by switching primed and unprimed and changing  $v$  to  $-v$ :

$$u'_x = \frac{u_x - v}{1 - (v/c^2)u_x} \quad u'_y = \frac{u_y}{\gamma[1 - (v/c^2)u_x]} \quad u'_z = \frac{u_z}{\gamma[1 - (v/c^2)u_x]}$$

### **3.8 : Twin Paradox**

#### **The Set-up**

Twins Mary and Frank at age 30 decide on two career paths: Mary decides to become an astronaut and to leave on a trip 8 lightyears (ly) from the Earth at a great speed and to return; Frank decides to reside on the Earth.

**The Problem :** Upon Mary's return, Frank reasons that her clocks measuring her age must run slow. As such, she will return younger. However, Mary claims that it is Frank who is moving and consequently his clocks must run slow.

**The Paradox :** Who is younger upon Mary's return?

#### **The Resolution**

- 1) Frank's clock is in an **inertial system** during the entire trip; however, Mary's clock is not. As long as Mary is traveling at constant speed away from Frank, both of them can argue that the other twin is aging less rapidly.
- 2) When Mary slows down to turn around, she leaves her original inertial system and eventually returns in a completely different inertial system.

- 3) Mary's claim is no longer valid, because she does not remain in the same inertial system. There is also no doubt as to who is in the inertial system. Frank feels no acceleration during Mary's entire trip, but Mary does.
- 4) Frank's clock is in an **inertial system** during the entire trip; however, Mary's clock is not. As long as Mary is traveling at constant speed away from Frank, both of them can argue that the other twin is aging less rapidly.
- 5) When Mary slows down to turn around, she leaves her original inertial system and eventually returns in a completely different inertial system.
- 6) Mary's claim is no longer valid, because she does not remain in the same inertial system. There is also no doubt as to who is in the inertial system. Frank feels no acceleration during Mary's entire trip, but Mary does.

## **2.9: Spacetime**

- When describing events in relativity, it is convenient to represent events on a spacetime diagram.
- In this diagram one spatial coordinate  $x$ , to specify position, is used and instead of time  $t$ ,  $ct$  is used as the other coordinate so that both coordinates will have dimensions of length.
- Spacetime diagrams were first used by H. Minkowski in 1908 and are often called Minkowski diagrams. Paths in Minkowski spacetime are called worldlines.

### **Spacetime Interval**

Since all observers "see" the same speed of light, then all observers, regardless of their velocities, must see spherical wave fronts.

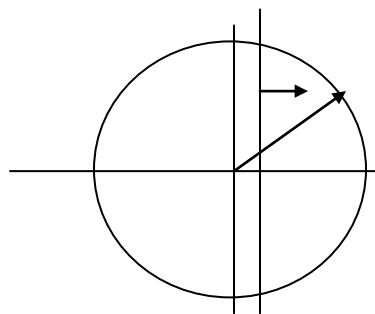

$$s^2 = x^2 - c^2 t^2 = (x')^2 - c^2 (t')^2 = (s')^2$$

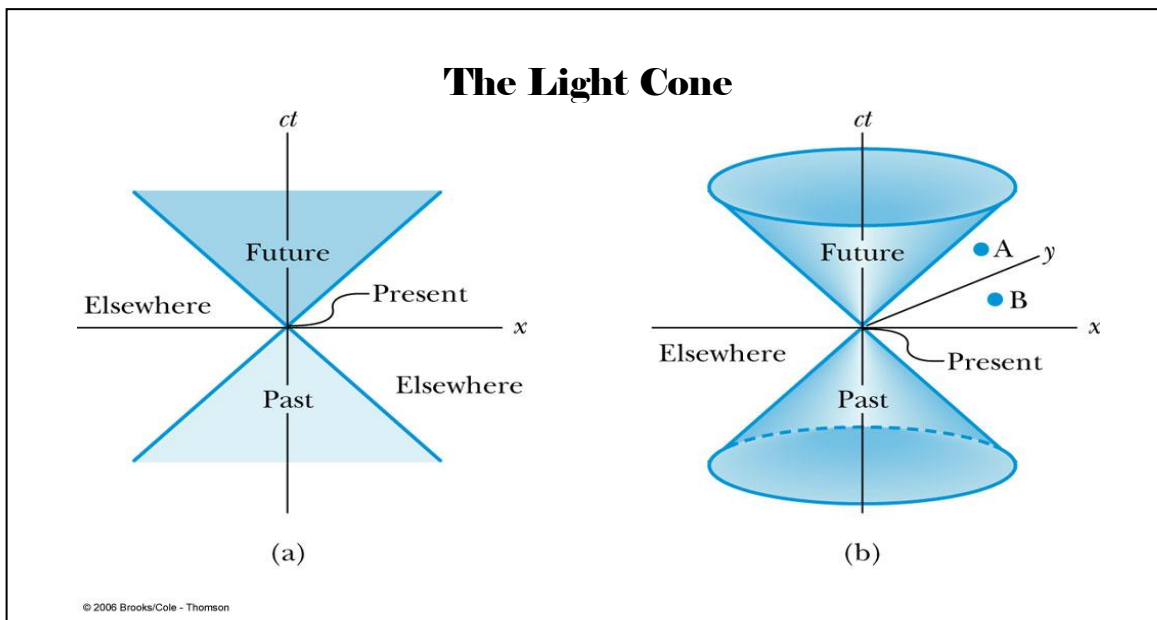
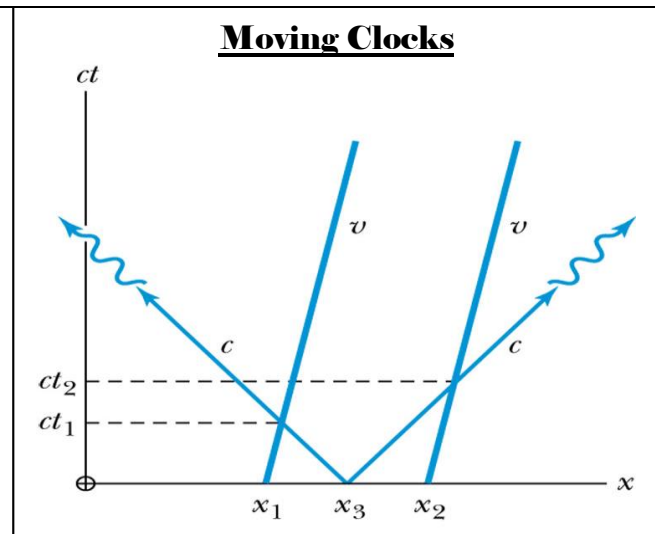
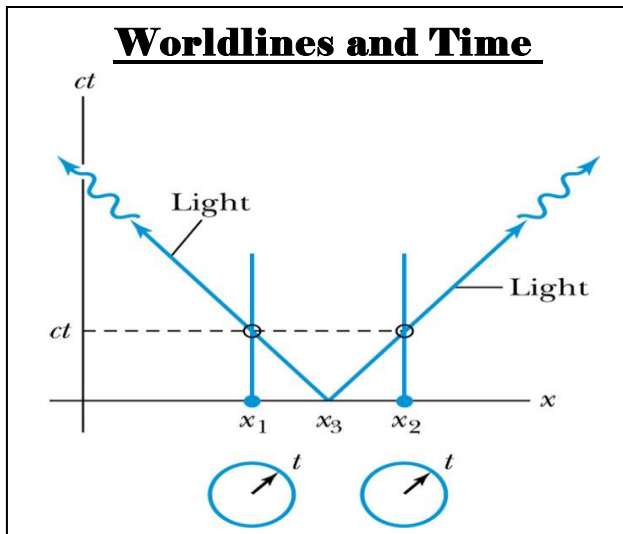
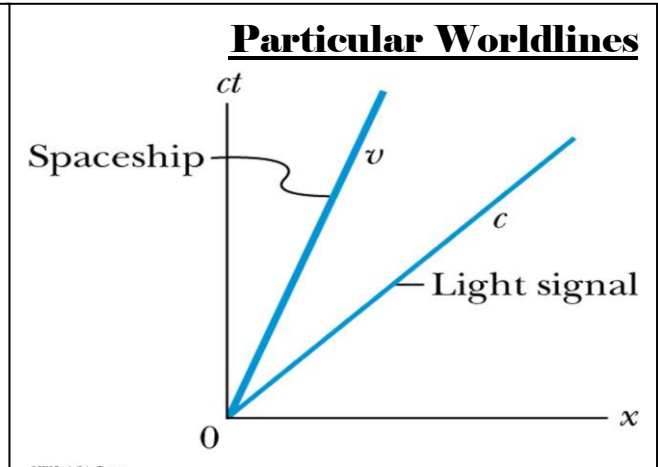
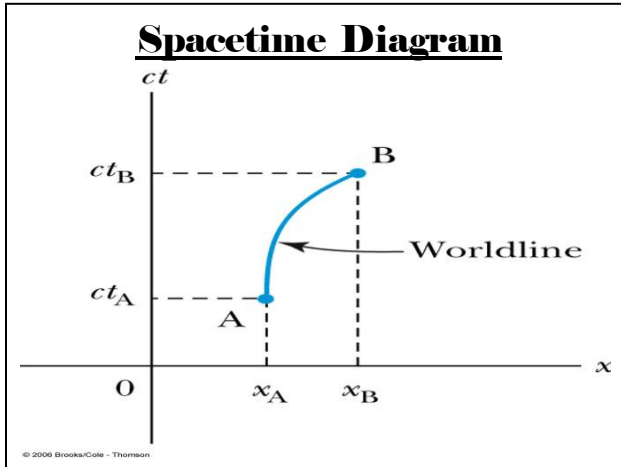

●If we consider two events, we can determine the quantity  $\Delta s$  between the two events, and we find that it is **invariant** in any inertial frame. The quantity  $\Delta s$  is known as **the spacetime interval** between two events.

There are three possibilities for the invariant quantity  $\Delta s^2$ :

- 1)  $\Delta s^2 = 0$ :  $\Delta x^2 = c^2 \Delta t^2$ , and the two events can be connected only by a light signal. The events are said to have a **lightlike** separation.
- 2)  $\Delta s^2 > 0$ :  $\Delta x^2 > c^2 \Delta t^2$ , and no signal can travel fast enough to connect the two events. The events are not causally connected and are said to have a **spacelike** separation.
- 3)  $\Delta s^2 < 0$ :  $\Delta x^2 < c^2 \Delta t^2$ , and the two events can be causally connected. The interval is said to be **timelike**.

### **3.10: The Doppler Effect**

●The Doppler effect of sound in introductory physics is represented by an *increased frequency* of sound as a source such as a train (with whistle blowing) approaches a receiver (our eardrum) and a *decreased frequency* as the source recedes.

●Also, the same change in sound frequency occurs when the source is fixed and the receiver is moving. The change in frequency of the sound wave depends on whether the source or receiver is moving.

●On first thought it seems that the Doppler effect in sound violates the principle of relativity, until we realize that there is in fact a special frame for sound waves. Sound waves depend on media such as air, water, or a steel plate in order to propagate; however, light does not!

### **Recall the Doppler Effect**

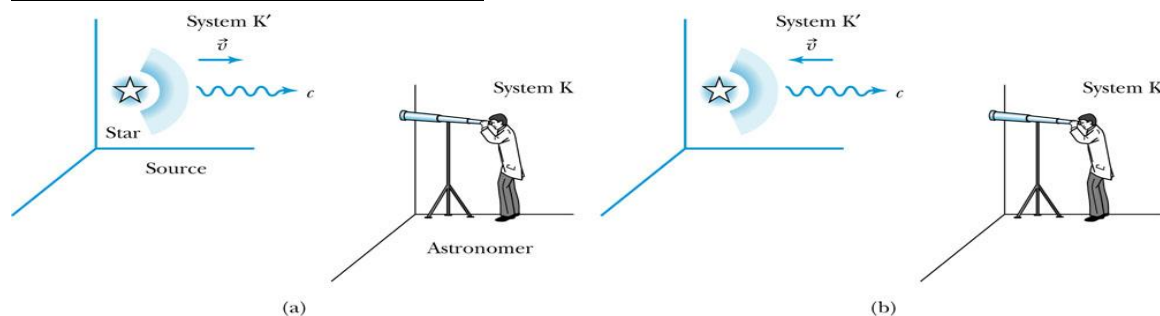

## The Relativistic Doppler Effect

Consider a source of light (for example, a star) and a receiver (an astronomer) approaching one another with a relative velocity  $v$ . Consider the receiver in system  $K$  and the light source in system  $K'$  moving toward the receiver with velocity  $v$ .

1) The source emits  $n$  waves during the time interval  $T$ .

2) Because the speed of light is always  $c$  and the source is moving with velocity  $v$ , the total distance between the front and rear of the wave transmitted during the time interval  $T$  is : **Length of wave train =  $cT - vT$**

## The Relativistic Doppler Effect:

Because there are  $n$  waves, the wavelength is given by

$$\lambda = \frac{cT - vT}{n}$$

And the resulting frequency is

$$f = \frac{cn}{cT - vT}$$

In this frame:  $f_0 = n / T'_0$  and  $T'_0 = \frac{T}{\gamma}$ ,

$$\text{Thus : } f = \frac{cf_0 T / \gamma}{cT - vT} = \frac{1}{1 - v/c} \frac{f_0}{\gamma} = \frac{\sqrt{1 - v^2/c^2}}{1 - v/c} f_0$$

### **Source and Receiver Approaching :**

With  $\beta = v / c$  the resulting frequency is given by:

$$f = \frac{\sqrt{1 + \beta}}{\sqrt{1 - \beta}} f_0 \quad \text{source and receiver approaching)}$$

### **Source and Receiver Receding**

In a similar manner, it is found that:

$$\text{(source and receiver receding) } f = \frac{\sqrt{1 - \beta}}{\sqrt{1 + \beta}} f_0$$

Equations (2.32) and (2.33) can be combined into one equation if we agree to use a + sign for  $\beta$  ( $+v/c$ ) when the source and receiver are approaching each other and a – sign for  $\beta$  ( $-v/c$ ) when they are receding. The final equation becomes

$$f = \frac{\sqrt{1 + \beta}}{\sqrt{1 - \beta}} f_0 \quad \text{Relativistic Doppler effect (2.34)}$$

### 3.11: Relativistic Momentum

Because physicists believe that the conservation of momentum is fundamental, we begin by considering collisions where there do not exist external forces and

$$dP/dt = F_{\text{ext}} = 0$$

Frank (fixed or stationary system) is at rest in system K holding a ball of mass  $m$ . Mary (moving system) holds a similar ball in system K that is moving in the  $x$  direction with velocity  $v$  with respect to system K.

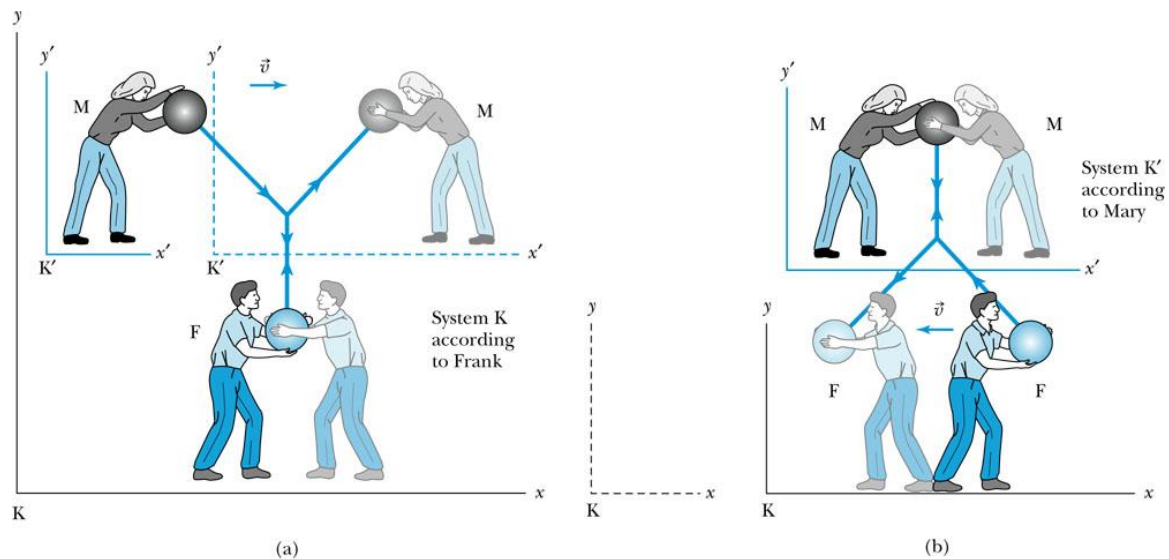

© 2005 Brooks/Cole - Thomson

● If we use the definition of momentum, the momentum of the ball thrown by Frank is entirely in the  $y$  direction:

$$p_{Fy} = mu_0$$

The change of momentum as observed by Frank is

$$\Delta p_F = \Delta p_{Fy} = -2mu_0$$

**According to Mary:**

• Mary measures the initial velocity of her own ball to be  $u'_{Mx} = 0$  and  $u'_{My} = -u_0$ . In order to determine the velocity of Mary's ball as measured by Frank we use the velocity transformation equations:

$$u_{Mx} = v$$

$$u_{My} = -u_0 \sqrt{1 - v^2/c^2}$$

Before the collision, the momentum of Mary's ball as measured by Frank becomes

$$\text{Before } p_{Mx} = mv$$

$$\text{Before } p_{My} = -mu_0 \sqrt{1 - v^2/c^2} \quad (2.42)$$

For a perfectly elastic collision, the momentum after the collision is

$$\text{After } p_{Mx} = mv$$

$$\text{After } p_{My} = +mu_0 \sqrt{1 - v^2/c^2} \quad (2.43)$$

The change in momentum of Mary's ball according to Frank is

$$\Delta p_M = \Delta p_{My} = 2mu_0 \sqrt{1 - v^2/c^2} \quad (2.44)$$

- The conservation of linear momentum requires the total change in momentum of the collision,  $\Delta p_F + \Delta p_M$ , to be zero. The addition of Equations (2.40) and (2.44) clearly does not give zero.
- *Linear momentum is not conserved if we use the conventions for momentum from classical physics even if we use the velocity transformation equations from the special theory of relativity.*
- There is no problem with the x direction, but there is a problem with the y direction along the direction the ball is thrown in each system.
- Rather than abandon the conservation of linear momentum, let us look for a modification of the definition of linear momentum that preserves both it and Newton's second law.
- To do so requires reexamining mass to conclude that  $\vec{p} = m \frac{d\vec{r}}{dt} \gamma$

$$\vec{p} = \gamma m \vec{u} \quad \text{Relativistic momentum (2.48)}$$

$$\gamma = \frac{1}{\sqrt{1 - u^2/c^2}}$$

- Some physicists like to refer to the mass in Equation (2.48) as the *rest mass*  $m_0$  and call the term  $m = \gamma m_0$  the *relativistic mass*. In this manner the classical form of momentum,  $m$ , is retained. The mass is then imagined to increase at high speeds.
- Most physicists prefer to keep the concept of mass as an invariant, intrinsic property of an object. We adopt this latter approach and will use the term *mass* exclusively to mean *rest mass*. Although we may use the terms *mass* and *rest mass* synonymously, we will not use the term *relativistic mass*. The use of relativistic mass to often leads the student into mistakenly inserting the term into classical expressions where it does not apply.

### Exercise(1) .

Find (a) the classical and (b) the relativistic momentum of a 2.4 kg mass moving with a speed of  $0.81c$ .

### Solution

(a) For classical momentum,

$$p = mv = (2.4 \text{ kg})(0.81 \times 3.00 \times 10^8 \text{ m/s}) = 5.8 \times 10^8 \text{ kg.m/s}$$

(b) For relativistic momentum,

$$p = \frac{mv}{\sqrt{1 - \frac{v^2}{c^2}}} = \frac{(2.4 \text{ kg})(0.81 \times 3.00 \times 10^8 \text{ m/s})}{\sqrt{1 - \frac{(0.81c)^2}{c^2}}} = 9.9 \times 10^8 \text{ kg.m/s}$$

The relativistic momentum is always larger than that of the classical !



**Example 2**      **The Missing Mass**

A satellite, initially at rest in space, explodes into two pieces. One piece has a mass of 150kg and moves away from the explosion with a speed of  $0.76c$ . The other piece moves away in a opposite direction with a speed of  $0.88c$ . Find the mass of the second piece of the satellite.

**Solution**). The magnitude of the momentum for the piece 1 with  $m_1=150\text{kg}$ :

1). The magnitude of the momentum for the piece 1 with  $m_1=150\text{kg}$ :

$$p_1 = \frac{m_1 v_1}{\sqrt{1 - \frac{v_1^2}{c^2}}} = \frac{(150\text{kg})(0.76 \times 3.00 \times 10^8 \text{ m/s})}{\sqrt{1 - \frac{(0.76c)^2}{c^2}}} = 5.3 \times 10^{10} \text{ kg.m/s}$$

2). The magnitude of the momentum of the piece 2:

$$p_2 = \frac{m_2 v_2}{\sqrt{1 - \frac{v_2^2}{c^2}}} = \frac{(m_2)(0.88 \times 3.00 \times 10^8 \text{ m/s})}{\sqrt{1 - \frac{(0.88c)^2}{c^2}}}$$

3)  $p_2 = p_1$  :

$$\frac{(m_2)(0.88 \times 3.00 \times 10^8 \text{ m/s})}{\sqrt{1 - \frac{(0.88c)^2}{c^2}}} = 5.3 \times 10^{10} \text{ kg.m/s}$$

So,  $m_2 = 95 \text{ kg}$

**The mass increasing** :

From the relativistic equation of momentum :

$$p = \frac{m_0 v}{\sqrt{1 - \frac{v^2}{c^2}}} = \left( \frac{m_0}{\sqrt{1 - \frac{v^2}{c^2}}} \right) v = m v$$

The mass increasing with speed  $v$  as

$$m = \frac{m_0}{\sqrt{1 - \frac{v^2}{c^2}}}$$

Note: 1) When  $v = 0$ ,  $m = m_0$ ;

2) When  $v$  approaches  $c$ ,  $m$  approaches infinite.

### **3.12: Relativistic Energy**

• Due to the new idea of relativistic mass, we must now redefine the concepts of work and energy.

□ Therefore, we modify Newton's second law to include our new definition of linear momentum, and force becomes:

$$\vec{F} = \frac{d\vec{p}}{dt} = \frac{d}{dt}(\gamma m \vec{u}) = \frac{d}{dt} \left( \frac{m \vec{u}}{\sqrt{1 - u^2/c^2}} \right)$$

The work  $W_{12}$  done by a force to move a particle from position 1 to position 2 along a path is defined to be

$$W_{12} = \int_1^2 \vec{F} \cdot d\vec{s} = K_2 - K_1 \quad (2.55)$$

where  $K_1$  is defined to be the kinetic energy of the particle at position 1.

For simplicity, let the particle start from rest under the influence of the force and calculate the kinetic energy  $K$  after the work is done.

$$\begin{aligned} W = K &= \int \frac{d}{dt}(\gamma m \vec{u}) \cdot \vec{u} dt \\ K &= m \int dt \frac{d}{dt}(\gamma \vec{u}) \cdot \vec{u} = m \int u d(\gamma u) \end{aligned}$$

The limits of integration are from an initial value of 0 to a final value of  $\gamma u$ .

$$K = m \int_0^{\gamma u} u d(\gamma u) \quad (2.57)$$

The integral in Equation (2.57) is straightforward if done by the method of integration by parts. The result, called the *relativistic kinetic energy*, is

$$K = \gamma mc^2 - mc^2 = mc^2 \left( \frac{1}{\sqrt{1 - u^2/c^2}} - 1 \right) = mc^2(\gamma - 1) \quad (2.58)$$

Equation (2.58) does not seem to resemble the classical result for kinetic energy,  $K = \frac{1}{2}mu^2$ . However, if it is correct, we expect it to reduce to the classical result for low speeds. Let's see if it does. For speeds  $u \ll c$ , we expand  $\gamma$  in a binomial series as follows

$$\begin{aligned} K &= mc^2 \left( 1 - \frac{u^2}{c^2} \right)^{-1/2} - mc^2 \\ &= mc^2 \left( 1 + \frac{1}{2} \frac{u^2}{c^2} + \dots \right) - mc^2 \end{aligned}$$

where we have neglected all terms of power  $(u/c)^4$  and greater, because  $u \ll c$ .

This gives the following equation for the relativistic kinetic energy at low speeds:

$$K = mc^2 + \frac{1}{2}mu^2 - mc^2 = \frac{1}{2}mu^2 \quad (2.59)$$

which is the expected classical result. We show both the relativistic and classical kinetic energies in Figure 2.31. They diverge considerably above a velocity of  $0.6c$ .

### Relativistic and Classical Kinetic Energies

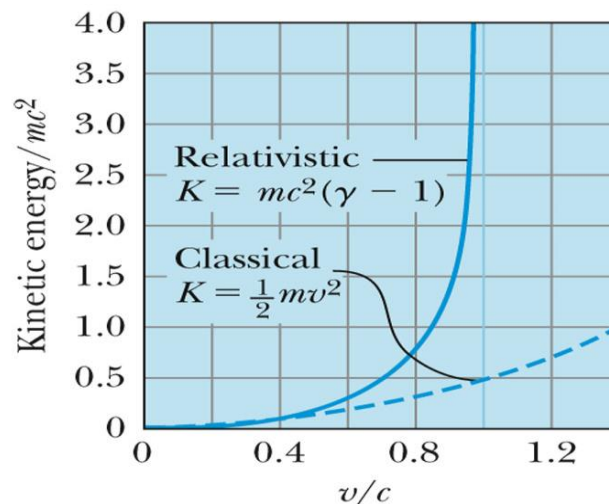

### Total Energy and Rest Energy

We rewrite Equation (2.58) in the form

$$\gamma mc^2 = \frac{mc^2}{\sqrt{1-u^2/c^2}} = K + mc^2 \quad (2.63)$$

The term  $mc^2$  is called the rest energy and is denoted by  $E_0$ .

$$E_0 = mc^2 \quad (2.64)$$

This leaves the sum of the kinetic energy and rest energy to be interpreted as the total energy of the particle. The total energy is denoted by  $E$  and is given by

$$E = \gamma mc^2 = \frac{mc^2}{\sqrt{1-u^2/c^2}} = \frac{E_0}{\sqrt{1-u^2/c^2}} = K + E_0 \quad (2.65)$$

### Momentum and Energy

$$p = \gamma mu = \frac{mu}{\sqrt{1-u^2/c^2}}$$

We square this result, multiply by  $c^2$ , and rearrange the result.

$$\begin{aligned} p^2 c^2 &= \gamma^2 m^2 u^2 c^2 \\ &= \gamma^2 m^2 c^4 \left( \frac{u^2}{c^2} \right) = \gamma^2 m^2 c^4 \beta^2 \end{aligned}$$

We use Equation (2.62) for  $\beta^2$  and find

$$p^2 c^2 = \gamma^2 m^2 c^4 \left( 1 - \frac{1}{\gamma^2} \right) = \gamma^2 m^2 c^4 - m^2 c^4$$

The first term on the right-hand side is just  $E^2$ , and the second term is  $E_0^2$ . The last equation becomes

$$p^2 c^2 = E^2 - E_0^2$$

We rearrange this last equation to find the result we are seeking, a relation between energy and momentum.

$$E^2 = p^2 c^2 + E_0^2 \quad (2.70)$$

or

$$E^2 = p^2 c^2 + m^2 c^4 \quad (2.71)$$

Equation (2.70) is a useful result to relate the total energy of a particle with its momentum. The quantities  $(E^2 - p^2c^2)$  and  $m$  are invariant quantities. Note that when a particle's velocity is zero and it has no momentum, Equation (2.70) correctly gives  $E_0$  as the particle's total energy.

### **2.13: Computations in Modern Physics**

- We were taught in introductory physics that the international system of units is preferable when doing calculations in science and engineering.
- In modern physics a somewhat different, more convenient set of units is often used.
- The smallness of quantities often used in modern physics suggests some practical changes.

### **Units of Work and Energy**

- Recall that the work done in accelerating a charge through a potential difference is given by  $W = qV$ .
- For a proton, with the charge  $e = 1.602 \times 10^{-19}$  C being accelerated across a potential difference of 1 V, the work done is

$$W = (1.602 \times 10^{-19})(1 \text{ V}) = 1.602 \times 10^{-19} \text{ J}$$

**Reference**

1. QuantumMechanics:TheoryandApplications,A.K.GhatakandS.Lokanathan,  
(Macmillan)
2. Introduction to Quantum Theory, David Park (DoverPublications)
3. TheoryandProblemsofModernPhysics,Schaum’soutline,R.Gautreau and  
W.Savin- (Tata McGraw-Hill)
4. Modern Physics, Kenneth S. Krane, Third Edition, 2012,
5. Physics of Atoms and Molecules Bransden and Joachim (PearsonIndia)
6. Wiley Modern Physics, John Morrison, Second Edition, 2015, Academic Press
7. Concepts of Modern Physics Arthur Beiser (McGrawHill)
8. Modern Physics Murugeshan and Sivaprasad(S.Chand)

**Practical Reference Books:**

9. Advanced Practical Physics for students, B.L. Flint and H.T. Worsnop, 1971,  
Asia Publishing House
10. Advanced level Physics Practicals, Michael Nelson and Jon M. Ogborn, 4th  
Edition, reprinted 1985, Heinemann Educational Publishers
11. A Text Books Book of Practical Physics, I.Prakashand Ramakrishna, 11th Edn,  
2011,Kitab Mahal.

.....