



مقرر 432 ف

فيزياء الليزر

**Laser Physics**

الفرقة الرابعة علوم

شعبة الفيزياء

د/ عادل جادالكريم عبادي

قسم الفيزياء - كلية العلوم

العام الجامعي  
2023 / 2022 م

## Contents

Chapter 1 Introduction to Laser Essentials	
page	Topic
5	<u>Electromagnetic Radiation</u>
5	<u>Frequency</u>
6	<u>Wave Description</u>
6	Wavelengths Comparison
8	Electromagnetic Radiation in Matter
9	Bohr model of the atom
10	<u>Energy States (Levels)</u>
11	<u>Photons and the energy diagrams</u>

Chapter 2 Basics of laser physics	
page	Topic
<u>14</u>	<u>LIGHT EMISSION AND ABSORPTION</u>
<u>15</u>	QUANTIZATION
<u>15</u>	PHOTONS
<u>17</u>	What is LASER?
<u>17</u>	Properties of LASER
<u>21</u>	Basic components of the laser device
<u>22</u>	How the First Ruby Laser Works
<u>23</u>	The Interaction of Electromagnetic Radiation with Matter
<u>24</u>	Average Lifetime
<u>25</u>	ATOMIC EXCITATION AND EMISSION
<u>25</u>	EMISSION SPECTRA
<u>26</u>	<u>ABSORPTION SPECTRA</u>
<u>27</u>	<u>FLUORESCENCE</u>
<u>28</u>	<u>Light-Emitting Diodes</u>
	<b>laser effects</b>

<u>Chapter 4</u> <u>General Description of LASER</u> <u>and LASER OPERATION</u>	
<u>31</u>	<u>LASER OPERATION</u>
<u>31</u>	<u>Stimulated Emission</u>
<u>32</u>	<u>Population Inversion</u>
<u>34</u>	<u>Optical Cavity</u>
<u>35</u>	<u>TYPES OF LASERS Gas Lasers</u>
<u>35</u>	<u>Solid-State Lasers</u>
<u>36</u>	<u>Semiconductor Diode Lasers</u>
<u>37</u>	<u>Common features of lasers Light amplifying media</u>
<u>37</u>	<u>pumping</u>
<u>39</u>	<u>Laser oscillator</u>
<u>43</u>	<u>Optical feedback and laser oscillation</u>
<u>44</u>	<u>The Einstein Relations</u>
<u>54</u>	<u>Three Level Laser and Four Level Laser</u>
<u>58</u>	<u>Laser classifications</u>
<u>59</u>	<u>Fiber Optics</u>
<u>Chapter 4 Laser Applications</u>	
<u>62</u>	<u>Industrial Applications</u>
<u>63</u>	<u>Medical Applications</u>
<u>66</u>	<u>Military Applications</u>
<u>68</u>	<u>Daily applications</u>
<u>69</u>	<u>Optical Fiber Communications</u>
<u>72</u>	<u>Holograms for exhibitions and museums</u>
<u>73</u>	<u>Scientific/Research Applications</u>
<u>75</u>	<u>Special applications</u>
<u>76</u>	<u>Fiber laser</u>
<u>77</u>	<u>Classifications of lasers into groups</u>
<u>83</u>	<u>Glossary of laser definitions</u>
<u>90</u>	<u>References</u>
<u>91</u>	<u>Basic Laser Books</u>

## Chapter 1

# Introduction to Laser Essentials

Before studying about lasers, you must be familiar with basic terms used to describe electromagnetic waves:

Wavelength ( $\lambda$ ) Frequency ( $\nu$ ) Period (T) Velocity of light (c) Index of refraction (n). We will briefly review these terms, but it is much better if you are familiar with: Some terms from geometric optics such as: refraction, reflection, thin lenses etc. Some terms from "Modern Physics" such as photons, Models of atoms, etc.

### Electromagnetic Radiation

Electromagnetic Radiation is a **transverse wave**, advancing in vacuum at a constant speed which is called: **velocity of light**.

All electromagnetic waves have the same velocity in vacuum, and its value is approximately:

$$c = 300,000 \text{ [km/sec]} = 3 \cdot 10^8 \text{ [m/sec]}$$

One of the most important parameters of a wave is its **wavelength**.

**Wavelength ( $\lambda$ ) (Lamda)** is the distance between two adjacent points on the wave, which have the same **phase**. As an example (see figure below) the distance between two adjacent peaks of the wave.

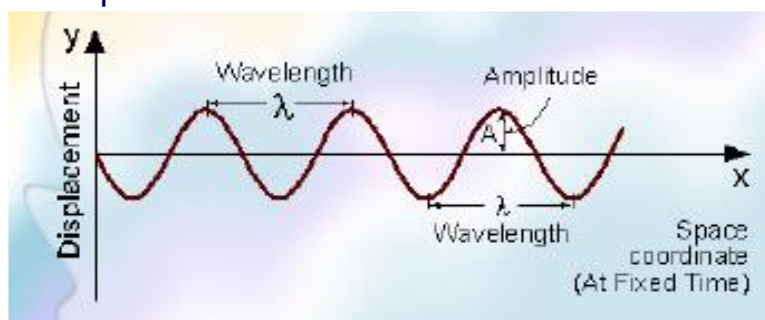

**Frequency** In a parallel way it is possible to define a wave by its **frequency**.

**Frequency ( $\mu$ )** is defined by the number of times that the wave oscillates per second.

Between these two parameters the relation is:  $c = \lambda * \mu$

From the physics point of view, **all electromagnetic waves are equal (have the same properties)** except for their **wavelength (or frequency)**.

As an example: the speed of light is the same for visible light, radio waves, or x-rays.

## Wave Description

A wave can be described in two standard forms:

1. Displacement as a function of **space** when time is held constant.
2. Displacement as a function of **time** at a specific place in space

### Displacement as a function of space

Displacement as a function of **space**, when time is "frozen" (held constant). In this description, the minimum distance between two adjacent points with the same phase is wavelength ( $\lambda$ ). Note that the horizontal (x) axis is **space coordinate**

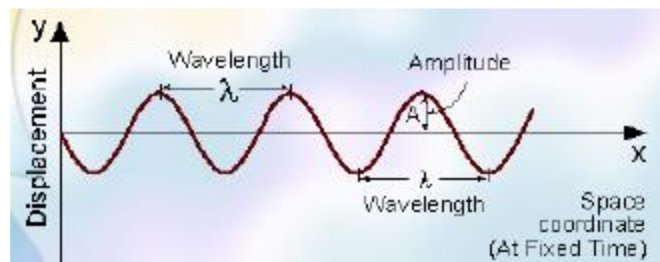

$A = \text{Amplitude} = \text{Maximum displacement from equilibrium}$

### Displacement as a function of time

Displacement as a function of **time**, in a specific place in **space**, as described in figure. In this description, the minimum distance between two adjacent points with the same phase is period (T). Note that the horizontal (x) axis is **time coordinate**

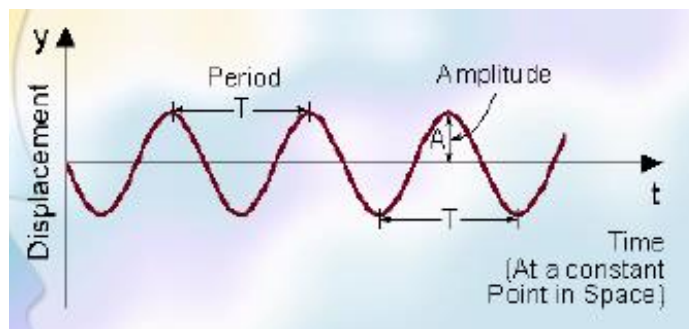

### Wavelengths Comparison

The Figure describes how two different waves (with different wavelengths) look at a specific moment in time. Each of these waves can be uniquely described by its wavelength.

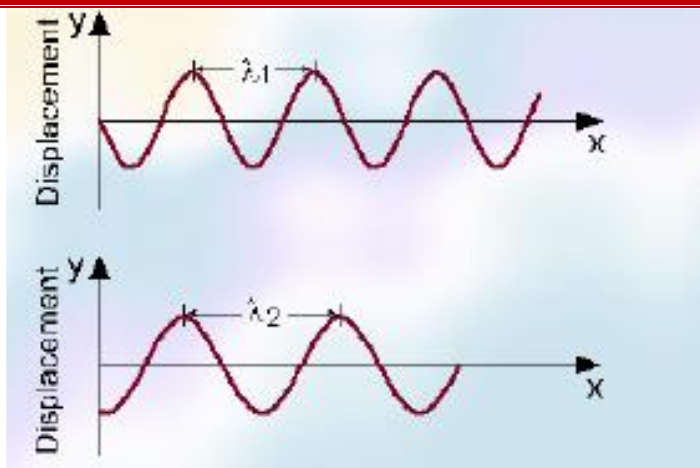

Photon Energy	Wavelength	Frequency	Common Name For the Spectral Region
$E$ [eV]	$\lambda$ [ $\mu\text{m}$ ]	$\nu$ [Hz]	
$E = h\nu = \frac{hc}{\lambda} = \frac{h}{T}$	$\lambda = \frac{c}{\nu} = cT$	$\nu = \frac{c}{\lambda} = \frac{E}{h} = \frac{1}{T}$	
$10^8$	$10^{-3}$	$10^{17}$	$\gamma$ Rays
100	0.01	$10^{16}$	X-Rays
10	0.1	$10^{15}$	UV= Ultra-Violet
1	0.4 0.7	$10^{14}$	Visible Spectrum
0.1	10	$10^{13}$	IR= Infra-Red
0.01	100	$10^{12}$	
$10^{-3}$	$10^3$	$10^{11}$	Microwave
$10^{-4}$	$10^4$	$10^{10}$	Radio Waves

The electromagnetic spectrum

The most important ideas summarized in figure are:

1. Electromagnetic waves span over many orders of magnitude in wavelength (or frequency).
2. The frequency of the electromagnetic radiation is inversely proportional to the wavelength.
3. The visible spectrum is a very small part of the electromagnetic spectrum.
4. Photon energy increases as the wavelength decreases. The shorter the wavelength, the more energetic are its photons.

Examples for electromagnetic waves are:

- **Radio-waves** which have wavelength of the order of **meters**, so they need big antennas.
- **Microwaves** which have wavelength of the order of **centimeters**. As an example: in a **microwave oven**, these wavelengths can not be transmitted through the protecting metal grid in the door, while the **visible spectrum** which have much shorter wavelength allow us to see what is cooking inside the microwave oven through the protecting grid.
- **x-Rays** which are used in medicine for taking pictures of the bone structure inside the body.
- **Gamma Rays** which are so energetic, that they cause ionization, and are classified as ionizing radiation.

**Electromagnetic Radiation in Matter**

Light Velocity in Matter

When electromagnetic radiation passes through matter with index of refraction  $n$ , its **velocity** ( $v$ ) is less than the velocity of light in vacuum ( $c$ ), and given by the equation:

$$v = c / n$$

(speed of light in vacuum) / (speed of light in matter)  $n = c/v$

Gases, including air, are usually considered as having index of refraction equal to vacuum  $n_0=1$ .

The values of the index of refraction of most materials **transparent in the visible spectrum is between 1.4-1.8**, while those of materials **transparent in the Infra-Red (IR) spectrum are higher, and are 2.0-4.0**.

Wavelength in Matter

We saw that the velocity of light in matter is slower than in vacuum. This slower velocity is associated with reduced wavelength:  $\lambda = \lambda_0 / n$ , while the **frequency remains the same**

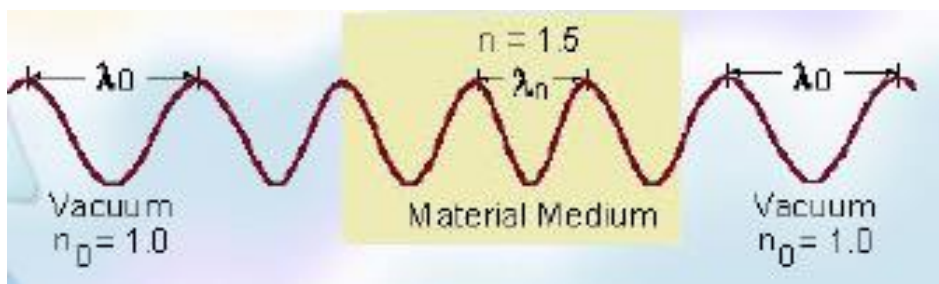

**Refraction of Light Beam - Snell Law**



## Laser Physics

---

Reducing the velocity of light in matter, and reducing its wavelength, causes **refraction of the beam of light**.

While crossing the border between two different materials, the light changes its direction of propagation according to the **Snell Equation**

$$n_1 \cdot \sin(\theta_1) = n_2 \cdot \sin(\theta_2)$$

In 1913, Niels Bohr proposed a model of the hydrogen atom that incorporated the quantum aspects of Planck's hypothesis. Bohr adapted the existing planetary model of the atom, in which electrons revolved around a central nucleus, but added a key assumption: Bohr suggested that the electron's energy was only allowed to take on particular values and could not be anything in between those values. Furthermore, these energy levels correspond to specific fixed orbits around the nucleus (). A staircase serves as a useful analogy for the energy levels in an atom. Just as it's not possible for an object to reside in between two steps, an electron cannot occupy a state between two energy levels.

Bohr indexed the energy levels of the hydrogen atom according to a quantum number that could take the whole number values  $n = 1, 2, 3$ , and so on. The lowest allowable energy level, for which  $n = 1$ , is known as the ground state of the atom. In this state, the electron is also closest to the nucleus. Energy levels that are higher than the ground state are called excited states. Electrons must accept energy, for example by absorbing a photon, in order to move from one energy level to a higher one. Only certain frequencies of photons can be absorbed by an individual atomic system, and therefore each energy level diagram is quantized by the allowable transitions between states, which is unique for each type of atom.

Hydrogen is the simplest atom in the universe due to its single orbital electron. As a result, physicists often use it as the standard model to explain the basic rules of quantum mechanics and atomic energy levels. In atoms not react or combine easily with other elements. In contrast, alkali metals such as lithium and sodium have an unpaired electron and tend to be highly reactive.

There are many more types of energy levels in addition to those found in solitary atoms. Molecules have electronic energy levels of their own, which become more complex as the number of electrons and atoms in the molecule increases. Molecules also have energy levels that depend on vibrations of atoms within them and on the rotation of the entire molecule. All of these energy levels are quantized as well.

### The Essentials: Atoms Bohr model of the atom

**Lasing action** is a process that occurs in matter.

Since matter is composed of atoms, we need to understand about the structure of the atom, and its energy states.

We shall start with the **semi-classical model**, as suggested in 1913 by **Niels Bohr**, and called: **The Bohr model of the atom**. According to this model, every ato



m is composed of a very **massive nucleus** with a **positive electric charge ( $Ze$ )**, around it electrons are moving in specific paths.

$Z$  = Number of protons in the nucleus,  $e$  = Elementary charge of the electrons:  $e = 1.6 \times 10^{-19}$  [Coulomb]

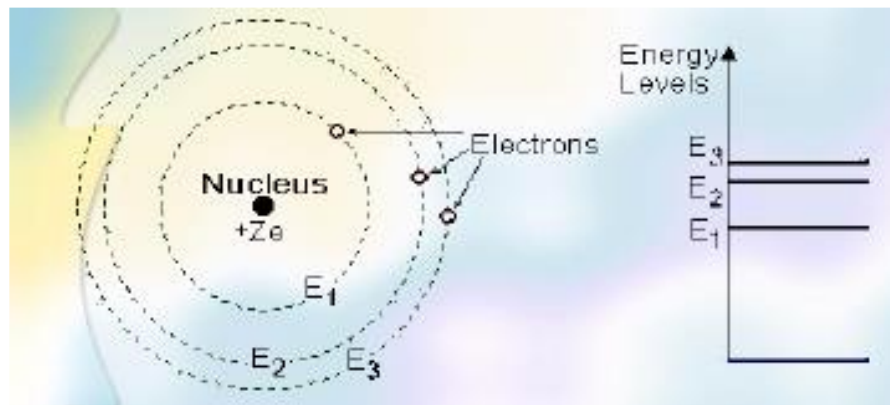

Every "**allowed orbit**" of the electron around the nucleus, is connected to a specific energy level.

The energy level is higher as the distance of the "orbit" from the nucleus increases. Since for each atom there are only certain "**allowed orbits**", only certain discrete energy levels exist, and are named: **E1, E2, E3**, etc

### **Energy States (Levels)**

Every atom or molecule in nature has a specific structure for its energy levels.

The lowest energy level is called the **ground state**, which is **the naturally preferred energy state**. As long as **no energy** is added to the atom, the electron will remain in the ground state.

**When the atom receives energy** (electrical energy, optical energy, or any form of energy), this energy is transferred to the electron, and raises it to a higher energy level.

The atom is then considered to be in an **excited state**.

The electron can stay only at the specific energy states (levels) which are unique for each specific atom. The **electron can not be in between these "allowed energy states"**, but it can "jump" from one energy level to another, while receiving or emitting specific amounts of energy.

These specific amounts of energy are equal to the **difference between energy levels within the atom**. Each amount of energy is called a "**Quantum**" of energy (The name "**Quantum Theory**" comes from these discrete amounts of energy).

## Laser Physics

---

### Photons and the energy diagrams

Electromagnetic radiation has, in addition to its wave nature, some aspects of "particle like behavior".

In certain cases, the electromagnetic radiation behaves as an ensemble of discrete units of energy that have momentum. These discrete units (quanta) of electromagnetic radiation are called "Photons".

The relation between the amount of energy (E) carried by the photon, and its frequency ( $\nu$ ), is determined by the formula (first given by Einstein):

$$E = h\nu$$

The proportionality constant in this formula is Planck's constant (h):

$$h = 6.626 \times 10^{-34} \text{ [Joule-sec]}$$

This formula shows that the frequency of the radiation ( $\nu$ ), uniquely determines the energy of each photon in this radiation.

$$E = h\nu$$

This formula can be expressed in different form, by using the relation between the frequency ( $\nu$ ) and the wavelength:  $c = \lambda\nu$  to get:

$$E = h \cdot c / \lambda$$

This formula shows that the energy of each photon is inversely proportional to its wavelength. This means that each photon of shorter wavelength (such as violet light) carries more energy than a photon of longer wavelength (such as red light). Since h and c are universal constants, so either wavelength or frequency is enough to fully describe the photon.

### Energy Levels

Achieving population inversion and sustaining a chain of stimulated emission events requires a configuration of energy levels with specific characteristics. If the excited atoms undergo spontaneous emission before stimulated emission can take place, there will not be a sustained beam of identical photons traveling in the same direction. For this reason, the excited state must be metastable to ensure that atoms will remain in that state long enough to sustain a population inversion. Some amount of spontaneous emission is unavoidable, but the longer the lifetime of the state, the easier it is to ensure that stimulated emission will dominate.

Although two-level lasers are theoretically possible under certain conditions, it is generally unfeasible to excite atoms directly into a metastable state. A more practical approach involves three energy levels: a ground state, an excited state with a short lifetime (relative to the other two transitions), and a metastable state with a slightly lower energy (FIGURE 58). Atoms are excited, or "pumped," into the higher energy level, where they quickly de-excite to the metastable level. The metastable level is chosen to have a lifetime generally a thousand times longer than that of the higher energy level. This process accumulates a large population of atoms in the metastable state, thereby establishing a population inversion between it and the ground state.

A laser is not itself a source of energy; rather, it needs energy from an external source in order to continually maintain population inversion. An external source of energy, called the pump source, excites the atoms in the active medium to the metastable state. Although a variety of techniques have been used in laser pumping, the most common methods are optical pumping and electrical pumping. Optical pumping is the use of an intense light source, such as a flashlamp, arc lamp, or external laser to excite atoms through photon absorption. Electrical pumping involves the use of an electric discharge or current to cause atomic excitation.

Three-level lasers are not an optimal solution for laser operation; a more efficient method involves four energy levels. A four-level laser adds an additional energy level above the ground state, which becomes the lower level for the laser emission transition. In other words, the lower level of the laser transition is not the ground state, which makes it easier to maintain a population inversion between the laser transition states. In a four-level laser, the lower level of the laser transition starts out nearly empty because it has a higher energy than the ground state. Thus, only exciting a small fraction of the ground state atoms to the metastable state is sufficient to establish a population inversion.

## pter 2

### Basics of laser physics

The first part of this section will cover the basic building blocks of laser operation, beginning with how light is emitted by atoms. From there, we will describe the processes of incandescence, fluorescence, and phosphorescence, all of which are relevant to laser operation. The section will conclude with an overview of how lasers work and a history of the development of the laser.

#### LIGHT EMISSION AND ABSORPTION

In order to understand how light is emitted, we must first consider the structure and properties of the atom. Atoms are the building blocks of the world around us. Atoms contain a nucleus, which is a dense core that comprises most of the atom's mass, and an outer region inhabited by bound electrons.

The nucleus is made up of positively charged particles called protons as well as neutrons, which have no electric charge. The nucleus is surrounded by negatively charged electrons. These electrons occupy "shells" that have different spatial distributions. Some are spherical, some are barbell-shaped, and others have more complex distributions. Due to the attractive force between oppositely charged particles, the farther an electron is from the nucleus, the more potential energy it has with respect to the nucleus.

The screenshot shows a software interface for building atoms. At the top left, there are controls for adding particles: Protons (red dots), Neutrons (grey dots), and Electrons (blue dots). The central area displays a 'Neutral Atom' of Helium, consisting of a nucleus with two protons and two neutrons, and a surrounding electron cloud. Below the atom are three bowls containing individual particles: Protons (red), Neutrons (grey), and Electrons (blue). On the right side, there is a periodic table with Helium (He) selected. Below the table are input fields for 'Net Charge' and 'Mass Number', both currently set to '+'. At the bottom right, there is a 'Show' menu with checkboxes for 'Element', 'Neutral/ion', and 'Stable/Unstable'. A circular refresh button is located at the bottom right corner of the interface.

A substance composed of only one kind of atom is called an element. Each element in the periodic table has a characteristic atomic number, which is equal to the number of protons in the nucle

us of an atom of that element. Electrons and protons have the same magnitude, but opposite sign, of electric charge. Because atoms are electrically neutral, they must have the same number of electrons as protons (). (Atoms can gain or lose electrons to become ions, which have an overall negative or positive charge.) Hydrogen, which has an atomic number of 1, contains a single proton in its nucleus, orbited by a single electron. Likewise, all carbon atoms (atomic number 6) contain six protons and six electrons.

## QUANTIZATION

Lasers are fundamentally quantum mechanical devices. That is, the operation of a laser is fully dependent on the quantum nature of light and matter. Let's explain what this means. Before 1900, scientists assumed energy could vary continuously and be endlessly subdivided. No experiment had provided evidence to contradict this viewpoint. In 1900, a German physicist named Max Planck () proposed that the energy could only be emitted or absorbed in discrete bundles that are multiples of a fundamental unit, or quantum, of energy. This relationship can be expressed as

$$E = nhf ,$$

where  $h = 6.63 \times 10^{-34} \text{ J s}$  is called Planck's constant;  $f$  is the frequency of oscillation; and  $n$  is a positive integer. That is, energy could be exchanged in amounts of  $hf$ ,  $2hf$ ,  $3hf$ , etc., but not anything in between. Because the energy can only take certain specific values, we say that it is "quantized." As an analogy, imagine dunes of sand that appear smooth from a distance, but are in fact coarse and grainy when observed close up. Planck's constant is small enough that we do not notice the quantization of energy in our everyday experience—the quantized packets of energy are too small to be individually perceived by our senses.

## PHOTONS

Experiments conducted around the same time as Planck's hypothesis revealed that light itself exhibits similar quantum behavior. Heinrich Hertz had discovered in 1887 that metals illuminated with ultraviolet light tended to produce sparks. J. J. Thomson later determined that these sparks were actually electrons being ejected from the surface of the metal. This phenomenon became known as the photoelectric effect. Physicists initially attempted to use Maxwell's electromagnetic wave model to explain the photoelectric effect. They reasoned that since electromagnetic fields exert forces on charged particles, the oscillating fields in a light wave could theoretically push an electron within an atom back and forth as one might push a child on a swing. Eventually, the electron could have enough energy to escape the atom, and the metal, altogether.

## Laser Physics

photoelectric effect. Light below a certain frequency does not eject electrons, as higher-frequency light ejects electrons with more energy. The observations cannot be explained by treating light as a wave.

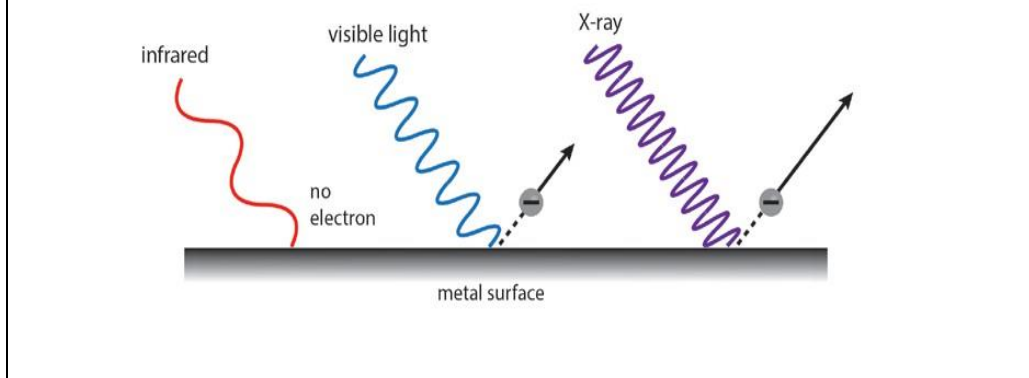

However, further investigation of the photoelectric effect in 1902 resulted in several observations that contradicted physicists' expectations under the wave model. For instance, electrons were emitted almost instantaneously (less than a nanosecond) after the metal was illuminated, whereas the wave model predicted a time delay.

Furthermore, light below a certain frequency was not observed to eject any electrons, regardless of the intensity of the light. According to the existing theory, any frequency of light would be expected to eject electrons if the incident light was sufficiently intense. In addition, increasing the frequency of the incident light resulted in higher-energy electrons being emitted—however, there should have been no relationship between light frequency and electron energy when treating light as a wave ().

Drawing from Planck's theory, in 1905 Albert Einstein proposed that light itself is quantized into discrete energy packets that exhibit properties of particles. Einstein argued that the photoelectric effect could only be explained as packets of light colliding with electrons, thereby transferring their energy and ejecting the electrons from the metal. These packets of light energy eventually became known as photons. Furthermore, Einstein argued that the energy of these photons obeys Planck's relation  $E = hf$ , which was consistent with experimental results from the photoelectric effect. Thus, an individual photon from a higher-frequency beam of light carries more energy than a photon from a lower-frequency beam of light. Einstein was awarded the Nobel Prize in 1921, in part for his explanation of the photoelectric effect.

Photons are packets of energy transferred from the electromagnetic field. Although they have zero mass, photons have both energy and momentum. It takes an extremely large number of photons to make up most of the radiation we experience on a daily basis because the energy of any individual photon in the visible spectrum is so small.

For example, a quick estimate can be made that a single 100 watt light bulb will release on the order



of 1021 photons every second. Normally we do not “feel” an individual photon any more than we would feel an individual droplet of water while swimming through the ocean.

Before we move on, we should address an important point. Although they seem contradictory, the photon, or particle, nature of light does not invalidate the wave nature of light we discussed in the previous section. Light exhibits properties of both waves and particles, depending on the experiment (). This seemingly contradictory behavior is known as wave-particle duality. The photoelectric effect is a demonstration of the particle nature of light, whereas double-slit interference is a wave phenomenon. Wave-particle duality is a puzzling aspect of the physical world that took the world’s leading physicists many years to accept.

## **What is LASER?**

### **Light Amplification by Stimulated Emission of Radiation.**

**Light:** All light is a form of electromagnetic radiation that is visible to the human eye.

**Amplification:** This is simply the process of making something bigger or more powerful. When you turn up the volume on a radio, you are amplifying the sound; but with lasers, amplification makes the light brighter.

**Stimulated:** To stimulate means to stir to action. Laser light is created when a burst of light (electricity) excites the atoms in the laser to emit photons. These photons then stimulate the creation of additional identical photons to produce the bright laser light.

**Emission:** The word "emission" refers to something that is sent out or given off. Stimulated laser emission consists of large numbers of photons that create the intense laser light.

**Radiation:** The laser light is a form of energy that radiates, or moves out, from the laser source.

## **Properties of LASER**

Laser light has several properties that make it useful for many practical applications. Laser light is monochromatic, directional, and coherent. By comparison, ordinary white light is a combination of many wavelengths of light, emits isotropically (in all directions), and is a mixture of many out-of-phase wavelengths. These three properties of laser light are what can make it more hazardous than ordinary light— laser light is capable of depositing a lot of energy within a small area. We will discuss each of these properties in greater detail.

### **Monochromatic**

The light emitted from a laser is **monochromatic**, it is of one wavelength (color). In contrast, ordinary white light is a combination of many different wavelengths (colors).



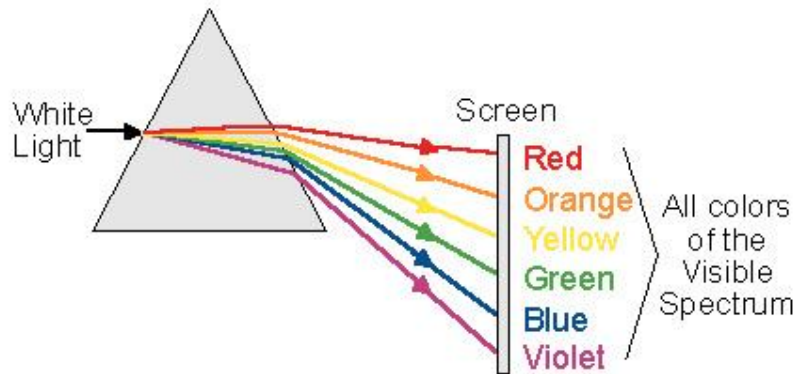

Figure : White light passing through a prism

Because the photons emitted by a laser all correspond to the same energy transition, they all have the same frequency. Single-frequency light such as this is often described as monochromatic. In comparison, recall that thermal radiation (such as that produced by an incandescent light source) produces a continuous spectrum of frequencies with different intensities.

Laser light is not perfectly monochromatic; there is some “spread” due to Doppler shifts from the motion of atoms or molecules within the active medium. The line width or bandwidth of a laser describes the spread of its spectrum of emitted frequencies. However, this spread is extremely narrow compared to the spectrum of frequencies emitted by, say, an incandescent light bulb.

## Directional

Lasers emit light that is highly **directional**.

It is emitted as a narrow beam in a specific direction.

Ordinary light (sun, light bulb, a candle), is emitted in many directions away from the source

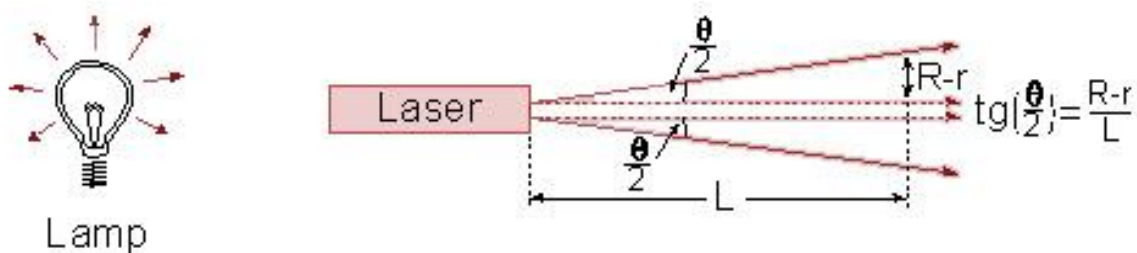

Figure : comparison between the light out of a laser, and the light out of an incandescent lamp

The light from a laser emerges as a very narrow beam with very little divergence, or spread. We often refer to a beam with this property as being collimated. If you’ve used a laser pointer while giving a presentation or distracting a feline companion, you are familiar with the ability of lasers to project a point of light, even from a relatively large distance. A laser’s high degree of collimation is a direct result of the precise alignment of the parallel mirrors that form the optical cavity. As the light waves reflect back and forth many times within the cavity, the mirrors constrain the waves to an axis perpendicular to the surfaces of both mirrors. Any light that is slightly “off-axis” will be lost from the cavity and thus will never form

part of the final beam.

The highly collimated nature of a laser beam makes it highly useful but also highly dangerous. You should never look directly into a laser beam because the highly parallel rays can focus to a nearly microscopic dot on the retina of your eye, causing almost instant damage to the retina. On the other hand, the ability of lasers to focus so precisely contributes to their wide range of both medical and industrial applications. In medicine, lasers can be used as sharp scalpels; in industry, they can serve as fast, powerful, and computer-controllable cutting tools.

## Coherence

### Coherent waves are waves that maintain the relative phase between them

Since **electromagnetic radiation** is a wave phenomena, every electromagnetic wave can be described as a sum (**superposition**) of sine waves as a function of time.

From **wave theory** we know that every wave is described by a **wave function**:

$$y = A\cos(\omega t + \phi)$$

$A$  = **Amplitude**.

$\omega = 2\pi\nu$  = **Angular Frequency**.

$\phi$  = **Initial Phase** of the wave (Describe the starting point in time of the oscillation).

$(\omega t + \phi)$  = **Phase** of the wave.

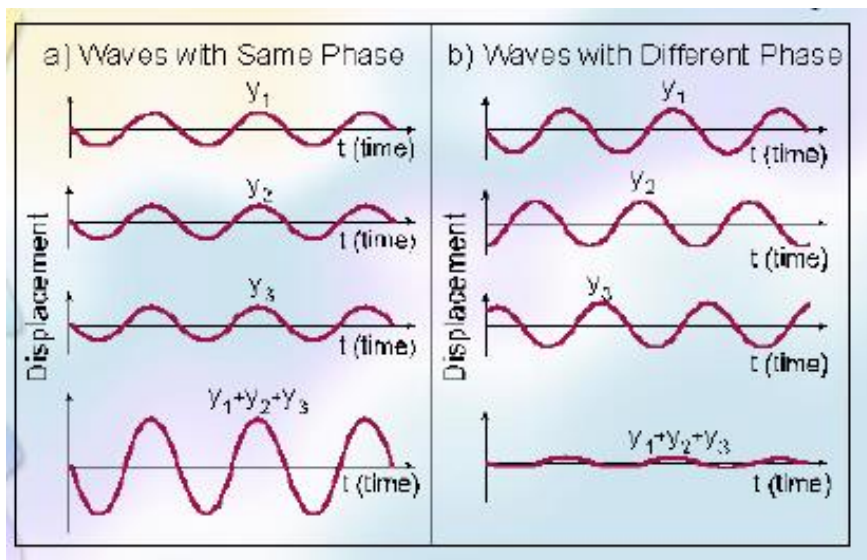

## Coherent

Light that is made up of waves that are "in-phase" relative to one another is said to be coherent. In other words, the peaks and troughs of the waves exactly align (FIGURE 61). An ordinary light source, such as an incandescent light bulb, produces light that is incoherent, meaning the waves have random phases. Even a collection of waves with identical frequencies can be incoherent if they are not in-phase

relativ

## Laser Physics

---

e to one another. LEDs, for example, emit light that is single-frequency but not coherent. Coherence in laser light is a direct consequence of stimulated emission.

Coherence in laser light is important for observing interference effects, which has important applications in precision measurement. Interferometry is the use of superimposed waves to make extremely fine measurements of small displacements, surface irregularities, or changes in refractive index. A basic interferometer uses a beam splitter and mirrors to overlap beams of light from a coherent source such as a laser. By slightly adjusting the path length difference between the two beams, shifts in the observed interference pattern will occur as the relative phases of the two beams change. This technique allows measurements to be made on the length scale of the wavelength of light being used.

### 1.4. PROPERTIES OF LASER BEAMS

Laser radiation is characterized by an extremely high degree of (1) monochromaticity, (2) coherence, (3) directionality, and (4) brightness. To these properties a fifth can be added,

\* One should note that, as a quasi-3-level laser becomes progressively closer to a pure 3-level laser, the assumption that the ground state population is changed negligibly by the pumping process will eventually not be justified. One should also note that in fiber lasers, where very intense pumping is readily achieved, the ground state can be almost completely emptied.

#### 1.4 • Properties of Laser Beams

viz., (5) short time duration. This refers to the capability for producing very short light pulses, a property that, although perhaps less fundamental, is nevertheless very important. We shall now consider these properties in some detail.

#### 1.4.1. Monochromaticity

Briefly, we can say that this property is due to the following two circumstances: (1) Only an e.m. wave of frequency  $\nu_0$  given by (1.1.1) can be amplified. (2) Since the two-mirror arrangement forms a resonant cavity, oscillation can occur only at the resonance frequencies of this cavity. The latter circumstance leads to the laser linewidth being often much narrower (by as much as to ten orders of magnitude!) than the usual linewidth of the transition  $2 \rightarrow 1$  as observed in spontaneous emission.

### 1.4.2. Coherence

To first order, for any e.m. wave, one can introduce two concepts of coherence, namely, spatial and temporal coherence.

To define spatial coherence, let us consider two points  $P_1$  and  $P_2$  that, at time  $t = 0$ , lie on the same wave-front of some given e.m. wave and let  $E_1(t)$  and  $E_2(t)$  be the corresponding electric fields at these two points. By definition, the difference between the phases of the two field at time  $t = 0$  is zero. Now, if this difference remains zero at any time  $t > 0$ , we will say that there is a perfect coherence between the two points. If this occurs for any two points of the e.m. wave-front, we will say that the wave has *perfect spatial coherence*. In practice, for any point  $P_1$ , the point  $P_2$  must lie within some finite area around  $P_1$  if we want to have a good phase correlation. In this case we will say that the wave has a *partial spatial coherence* and, for any point  $P$ , we can introduce a suitably defined coherence area  $S_c(P)$ .

To define temporal coherence, we now consider the electric field of the e.m. wave at a given point  $P$ , at times  $t$  and  $t + \tau$ . If, for a given time delay  $\tau$ , the phase difference between the two field remains the same for any time  $t$ , we will say that there is a temporal coherence over a time  $\tau$ . If this occurs for any value of  $\tau$ , the e.m. wave will be said to have perfect time coherence. If this occurs for a time delay  $\tau$  such that  $0 < \tau < \tau_0$ , the wave will be said to have partial temporal coherence, with a coherence time equal to  $\tau_0$ . An example of an e.m. wave with a coherence time equal to  $\tau_0$  is shown in Fig. 1.5. The figure shows a sinusoidal electric field undergoing random phase jumps at time intervals equal to  $\tau_0$ . We see that the concept of temporal coherence is, at least in this case, directly connected with that of monochromaticity. We will show, in fact, in Chap. 11, that any stationary e.m. wave with coherence time  $\tau_0$  has a bandwidth  $\Delta\nu \simeq 1/\tau_0$ . In the same chapter it will also be shown that, for a non-stationary but repetitively reproducing beam (e.g., a repetitively  $Q$ -switched or a mode-locked laser beam) the coherence time is not related to the inverse of the oscillation bandwidth  $\Delta\nu$  and may actually be much longer than  $1/\Delta\nu$ .

It is important to point out that the two concepts of temporal and spatial coherence are indeed independent of each other. In fact, examples can be given of a wave having perfect spatial coherence but only limited temporal coherence (or vice versa). If, for instance, the wave shown in Fig. 1.5 were to represent the electric fields at points  $P_1$  and  $P_2$  considered earlier,

the spatial coherence between these two points would be complete still the wave having a limited temporal coherence.

We conclude this section by emphasizing that the concepts of spatial and temporal coherence provide only a first-order description of the laser's coherence. Higher order coherence properties will in fact discussed in Chap. 11. Such a discussion is essential for a full appreciation of the difference between an ordinary light source and a laser. It will be shown in fact that, by virtue of the differences between the corresponding higher-order coherence properties, a laser beam is fundamentally different from an ordinary light source.

## 1.4.3. Directionality

This property is a direct consequence of the fact that the active medium is placed in a resonant cavity. In the case of the plane parallel one of Fig. 1.3, for example, only a wave propagating in a direction orthogonal to the mirrors (or in a direction very near to it) can be sustained in the cavity. To gain a deeper understanding of the directional properties of a laser beam (or, in general, of any e.m. wave), it is convenient to consider, separately, the case of a beam with perfect spatial coherence and the case of partial spatial coherence.

Let us first consider the case of perfect spatial coherence. Even for this case, a beam of finite aperture has unavoidable divergence due to diffraction. This can be understood with the help of Fig. 1.6, where a monochromatic beam of uniform intensity and plane wave-front is assumed to be incident on a screen  $S$  containing an aperture  $D$ . According to Huyghens' principle the wave-front at some plane  $P$  behind the screen can be obtained from the superposition of the elementary waves emitted by each point of the aperture. We thus see that, on account of the finite size  $D$  of the aperture, the beam has a finite divergence  $\theta_d$ . Its value can be obtained from diffraction theory. For an arbitrary amplitude distribution we get

$$\theta_d = \beta \lambda / D \quad (1.4.1)$$

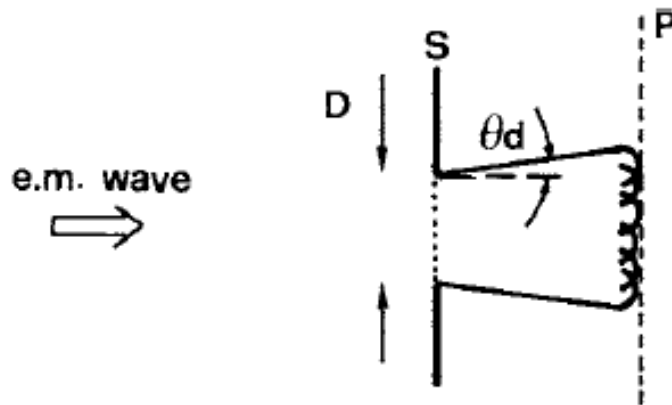

FIG. 1.6. Divergence of a plane e.m. wave due to diffraction.



where  $\lambda$  and  $D$  are the wavelength and the diameter of the beam. The factor  $\beta$  is a numerical coefficient of the order of unity whose value depends on the shape of the amplitude distribution and on the way in which both the divergence and the beam diameter are defined. A beam whose divergence can be expressed as in Eq. (1.4.1) is described as being *diffraction limited*.

If the wave has only a partial spatial coherence, its divergence will be larger than the minimum value set by diffraction. Indeed, for any point  $P'$  of the wave-front, the Huygens' argument of Fig. 1.6 can only be applied for points lying within the coherence area  $S_c$  around point  $P'$ . The coherence area thus acts as a limiting aperture for the coherent superposition of the elementary wavelets. The beam divergence will now be given by

$$\theta = \beta\lambda / [S_c]^{1/2} \quad (1.4.2)$$

where, again,  $\beta$  is a numerical coefficient of the order of unity whose exact value depends on the way in which both the divergence  $\theta$  and the coherence area  $S_c$  are defined.

We conclude this general discussion of the directional properties of e.m. waves by pointing out that, given suitable operating conditions, the output beam of a laser can be made diffraction limited.

#### 1.4.4. Brightness

We define the brightness of a given source of e.m. waves as the power emitted per unit surface area per unit solid angle. To be more precise, let  $dS$  be the elemental surface area at point  $O$  of the source (Fig. 1.7a). The power  $dP$  emitted by  $dS$  into a solid angle  $d\Omega$  around direction  $OO'$  can be written as

$$dP = B \cos \theta dS d\Omega \quad (1.4.3)$$

where  $\theta$  is the angle between  $OO'$  and the normal  $\mathbf{n}$  to the surface. Note that the factor  $\cos \theta$  arises simply from the fact that the physically important quantity for the emission along the  $OO'$  direction is the projection of  $dS$  on a plane orthogonal to the  $OO'$  direction, i.e.  $\cos \theta dS$ . The quantity  $B$  defined through Eq. (1.4.3) is called the source brightness at the point  $O$  in the direction  $OO'$ . This quantity will generally depend on the polar coordinates  $\theta$  and  $\phi$  of the direction  $OO'$  and on the point  $O$ . When  $B$  is a constant, the source is said to be isotropic (or a Lambertian source).

Let us now consider a laser beam of power  $P$ , with a circular cross section of diameter  $D$  and with a divergence  $\theta$  (Fig. 1.7b). Since  $\theta$  is usually very small, we have  $\cos \theta \cong 1$ . Since

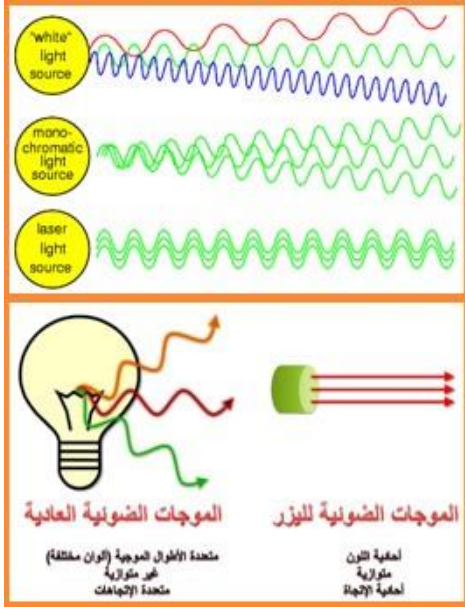

## خصائص ضوء الليزر:

يتميز ضوء الليزر على بقية أنواع الضوء الصادر عن المصادر الطبيعية كالشمس والمصابيح التقليدية والصناعية كالمصابيح الكهربائية بعدة خصائص مهمة تؤهله لاستخدامه في كثير من التطبيقات. ومن أهم هذه الخصائص:

**ج - الاتجاهية (Directionality)** وهي أن شعاع الليزر له زاوية انفرج (divergence angle) غاية في الصغر بحيث يمكنه أن يسير لمسافات طويلة دون أن تنتشر طاقته. فعلى سبيل المثال فإن زاوية انفرج شعاع ليزر نيون-هيليوم تبلغ جزئين من عشرة آلاف جزء من الدرجة وهذا يعني أنه إذا ما تم إرسال شعاع هذا الليزر من الأرض إلى القمر فسيكون قطره على القمر بحدود كيلومتر ونصف علماً بأن المسافة بين الأرض والقمر تبلغ 384 ألف كيلومتر. إن قطر شعاع هذا الليزر يبلغ مليمترين عند

خروجه من الليزر بينما سيكون قطره خمسة مليمترات فقط بعد أن يسير ألف كيلومتر. وتتحدد زاوية انفرج شعاع الليزر من عدة عوامل أهمها: عرض الشعاع عند خروجه من المصدر، وطول موجة الإشعاع حيث تتناسب عكسياً مع عرض الشعاع الابتدائي وطردياً مع طول الموجة أي أن الزاوية تقل مع زيادة عرض الشعاع ونقصان طول الموجة. وتستغل خاصية الاتجاهية في تطبيقات كثيرة كقياس المسافات البعيدة والقصيرة على السواء والتأشير على الأهداف بدقة متناهية كما في أنظمة المساحة ورسم الخطوط المستقيمة في أعمال الإنشاءات المختلفة.

**د - مترابطة:** بمعنى أنها تبقى محافظة على سماكتها واتساعها نفسها حتى بعد أن تقطع مسافة معينة. ويؤدي تراص وتجانس أشعة الليزر لامتكاها كثافة عالية من الطاقة يمكن أن ينتج ضوء الليزر تأثيرات نسيجية مختلفة اعتماداً على طول الموجة وكثافة الطاقة، ومدة التعرض، والخواص الامتصاصية للنسيج المستهدف.

**هـ - علو شدة ضوء الليزر (high intensity light)** وذلك بسبب أن شعاع الليزر له مقطع عرضي صغير جداً قد لا يتجاوز في بعض أنواعه عدة ميكرومترات مربعة وبما أن جميع الطاقة الضوئية الصادرة عن الليزر رغم قلتها تتركز ضمن هذا المقطع الصغير فإنها بإمكانها الحصول على شدة إضاءة قد تزيد بملايين المرات عن شدة الضوء الصادر عن الشمس أو المصابيح الكهربائية ولهذا فيمكن لشعاع الليزر أن يسير لمسافات كبيرة جداً دون أن يخبو ضوءه. ولتوضيح ذلك فإن ليزر بقدرة واحد واط وبمقطع عرضي مساحته ألف ميكرومتر مربع يعطي ضوء شدته بليون واط لكل متر مربع أي يزيد بمليون مرة عن شدة ضوء الشمس على سطح الأرض. وتستغل هذه الخاصية للضوء في حفر وقطع ولحام المواد بدقة كبيرة وفي إجراء العمليات الجراحية ومعالجة كثير من أمراض العيون والجلد.

**و - أحادية اللون (Monochromaticity)** حيث أن ضوء الليزر يتكون من حزمة ضيقة جداً من الترددات الضوئية بعكس أنواع الضوء الأخرى التي تتكون من طيف واسع جداً من الترددات ولذا فإنها تبدو للعين كضوء أبيض يحتوي على جميع ألوان الطيف المرئي بينما يبدو ضوء الليزر بلون واحد فقط عالي النقاء. وتستغل هذه الخاصية في استخدام ضوء الليزر كحامل للمعلومات بدلاً من الحاملات الرادي



وية خاصة في أنظمة اتصالات الألياف الضوئية التي تتطلب وجود مصادر ضوئية أحادية اللون أي أن عرض نطاق ترددات ضوءها غاية في الصغر .

ز - **الترابط (Coherence)** وهي أن الترددات التي يتكون منها شعاع الليزر لها نفس الطور (**phase**) وكذلك نفس الاستقطاب (**polarization**) وتستغل هذه الخاصية للحصول على أشكال تداخلية (**in-interference patterns**) لا يمكن الحصول عليها من خال استخدام أنواع الضوء الأخرى. ويستخدم التداخل الضوئي (**Interferometry**) في أشعة الليزر في تطبيقات لا حصر لها كما في قياس المسافات والسرعات ودراسة تركيب المواد والتصوير ثلاثي الأبعاد .

ح - **أنه يمكن التحكم بجهاز الليزر** بحيث يتم إطلاق ضوءه على شكل نبضات بمعدلات محددة ويمكن كذلك التحكم بعرض النبضة ليصل في بعض التطبيقات إلى عدة أجزاء من مليون بلون جزء من الثانية. ومن خلال تقليل عرض النبضة الضوئية فإنه يمكن الحصول على شدة ضوء غاية في العلو قد تصل إلى آلاف الميغواطوات ولكن لفترات زمنية قصيرة جداً وذلك مهما كانت كمية الطاقة التي تحملها النبضة. وتستخدم هذه الخاصية في تطبيقات لا حصر لها كإذابة أو تبخير المعادن أو قطع ولحام مختلف أنواع المواد أو إجراء العمليات الجراحية أو تسريع التفاعلات الكيميائية وحتى النووية. تستخدم أشعة الليزر القوية في الأغراض الصناعية، مثل تثقيب وقطع المعادن، بينما تستخدم الأشعة الضعيفة لتشغيل الأقراص البصرية التي تسجل عليها الموسيقى. أما الأشعة متوسطة القوة فتستخدم في الأغراض الطبية .

ط - **إمكانية الومضات الضوئية القصيرة والمتكررة.**

ي - **الانتقائية (أو النوعية):** حيث أن لكل ليزر يوجد نسيج أو عدة أنسجة يؤثر فيها الليزر بشكل نوعي دون أن يؤثر على سواها، ويؤدي هذا التأثير لإنتاج حرارة عالية في النسيج المستهدف وهذه الحرارة هي التي تعطي الليزر خواصه العلاجية، ويعتمد عمل الليزر على طول موجة، ولون نسيج المستهدف وحجمه. فعلى سبيل المثال هناك أنواع من الليزر تستهدف الهيموغلوبين المرتبط بذرة الأكسجين وبالتالي عند تأثيرها على الهيموغلوبين تنتج حرارة عالية تؤدي لتكسير الوعاء الدموي الشعري الحاوي على هذا الهيموغلوبين وبالتالي لانقطاع التدفق الدموي ويستفاد من هذه الخاصية على سبيل المثال في علاج وحمة الصباغ الخمري **Port wine stain** ، أو توسعات الأوعية الدموية الشعرية.

ك - **الأمان:** في حال استخدامه في المكان المناسب من الجسم من قبل طبيب مختص خبير متفهم لتأثيرات الليزر النوعية على الأنسجة قادر على حماية نفسه وحماية مريضه من تأثيرات الليزر غير المرغوب فيها .

وبما أن أشعة الليزر عبارة عن أشعة ضوئية مركزة، فإنها تخضع لقوانين الضوء من حيث: الانعكاس، والانكسار، والانحراف بواسطة المرايا والعدسات والمناشير الزجاجية. وقد تمكن الفنانون من استخدام أشعة الليزر في تشكيل صور رائعة باستخدام العدسات والمرايا والألياف البصرية **Fiber Optics**، وذلك من خلال انعكاس وانكسار أشعة الليزر المتوهجة، وتحويلها إلى نماذج ضوئية مبهرة.

ولكن يجب أن نشير إلى أن من أهم عيوب الليزر هو تدني كفاءة تحويل الطاقة فيه حيث تتراوح بين واحد بالمائة وعشرين بالمائة لمعظم أنواعه وهذا يعني أنه يلزم للحصول على واط واحد من ضوء ليزر كفاءته واحد بالمائة تزويده بمائة واط من الطاقة حيث تضيع التسعة وتسعون واط المتبقية كحرارة في داخل جسم الليزر وهذا يتطلب أنظمة تبريد معقدة خاصة في الأنواع التي تنتج قدرات عالية قد تصل لعدة كيلواطات كليزر ثاني أكسيد الكربون.

## Electromagnetic Radiation

Electromagnetic Radiation is a **transverse wave**, advancing in vacuum at a constant speed which is called: **velocity of light**.

All electromagnetic waves have the same velocity in vacuum, and its value is

### Laser Radiation Properties

#### In Summary: Laser Radiation Properties

1. **Very small divergence of the beam**. The beam is almost a **parallel beam** and move in **one direction in space - Directionality**.
2. High degree of **monochromaticity**. The radiation is almost one wavelength, as can be measured by the **very narrow spectral width**.

#### 3. Coherence.

The combination of these properties gives the laser radiation many advantages, like achieving **very high power densities**, not available from other sources.

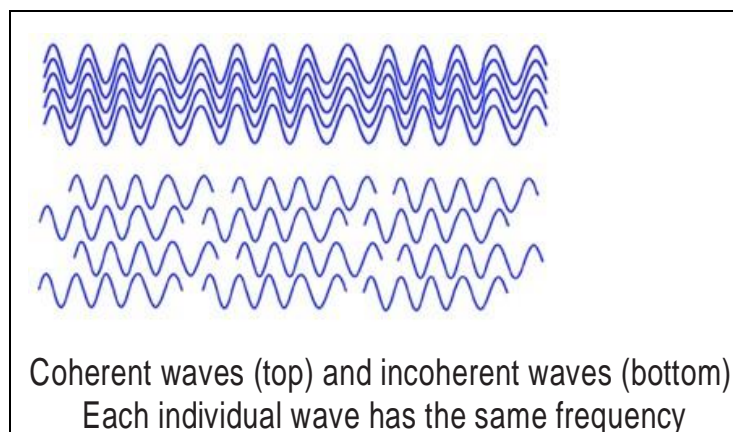
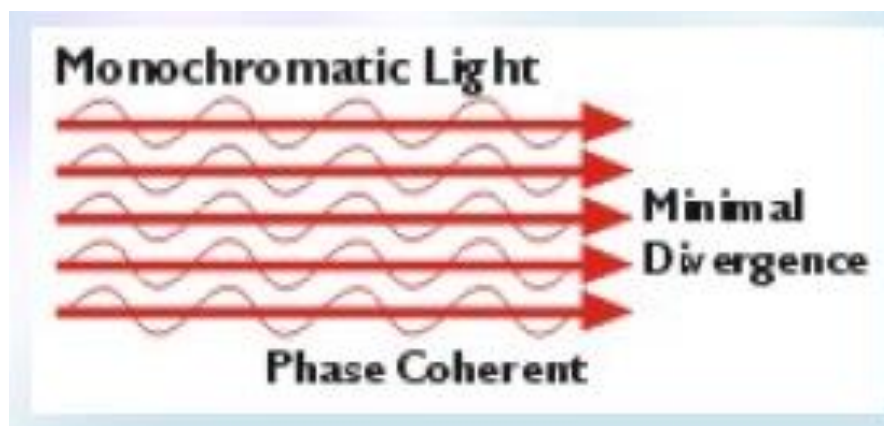

## Basic components of the laser device

In order for most laser to operate, three basic conditions must be satisfied

- (1) **The active medium:** Collections of atoms, molecules or ions in the form of solid or liquid or gas.
- (2) **population inversion**
- (3) **Optical feed back**

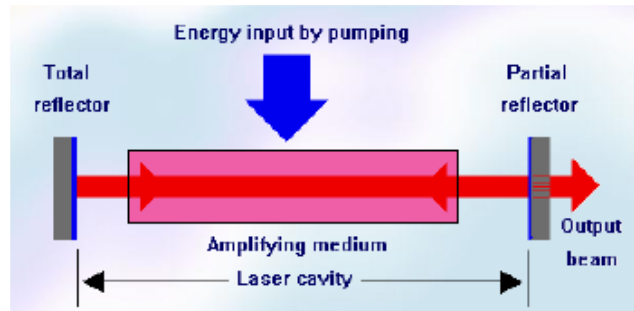

## How the First Ruby Laser Works

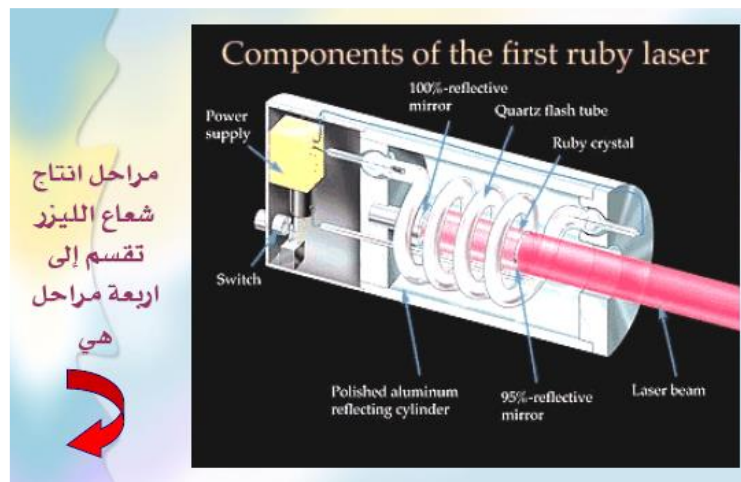

### Excitation

High-voltage electricity causes the quartz flash tube to emit an intense burst of light, exciting some of the atoms in the ruby crystal to higher energy levels.

### Photon Emission

At a specific energy level, some atoms emit photons. At first the photons are emitted in all directions.

Photons from one atom stimulate emission of photons from other atoms and the light intensity is rapidly amplified

### plification

Mirrors at each end reflect the photons back and forth, continuing this process of stimulated emission and amplification

### Laser Beam

The photons leave through the partially silvered mirror at one end. This is laser light.

### شروط حدوث الإشعاع المستحث (الليزر):

- أن تثار ذرات المادة لمستويات طاقة عالية وبأعداد هائلة ويتم ذلك بتطبيق طاقة إثارة مناسبة عليها.
- أن تكون المادة الفعالة المستعملة ذات ثلاث مستويات للطاقة أو أكثر.
- أن توضع المادة الفعالة بين مرآتين كي يتحقق انعكاسات متعددة للشعاع بينهما وبالتالي تحقيق أكبر عدد ممكن من الإصدارات المحثثة ذات الفوتونات المتماسكة.
- أن تطبق على الجملة طاقة حقن خارجية كي تحدث إثارة لذرات المادة وشحنها بالطاقة وبالتالي لجعلها جاهزة ومهيأة لإطاق الفوتونات المتماسكة حال حدوث اصطدامات مع فوتونات سريعة تعبر المادة .

### مبدأ عمل الليزر:

إن المبدأ الرئيسي الذي يقوم عليه عمل الليزر هو ظاهرة الانبعاث المستحث التي شرحناها آنفا وهناك شروط ثلاثة أساسية لكي يولد الليزر ضوءاً مترابطاً من خال هذه الظاهرة .

- الشرط الأول فهو توفر ما يسمى بالتوزيع الإسكاني المقلوب (**Population inversion**) للإلكترونات في ذرات المادة التي ستولد الضوء والذي يعني أن عدد الإلكترونات في الحالة المثارة يجب أن يكون أعلى منها في الحالة غير المثارة. وهذا الشرط لا يتحقق إلا في مواد معينة تسمى الوسط الفعال (**active medium**) التي يكون عدد المدارات في نطاق توصيلها (**conduction band**) ثلاثة أو أكثر وبحيث يوجد مدار شبه مستقر (**metastable**) بين المدار منخفض الطاقة والمدار عالي الطاقة. توجد شروط معينة كي يحدث ضمنها الإصدار المستحث وهي توازي ما تنبأ به أينشتاين.

فلو كان لدينا  $N$  ذرة ذات مستويين للطاقة  $N_1$  و  $E_1$  في الحالة الأساسية و  $N_2$  و  $E_2$  في الحالة المثارة. والإصدار المستحث يتناسب مع عدد الذرات في المستوى العلوي. وللحصول على إصدار المستحث كبير يجب أن يكون  $N_1 > N_2$  أي يجب قلب التوزيع الإسكاني ويطلق عليه في حالة إثارة خارجية اسم الضخ.

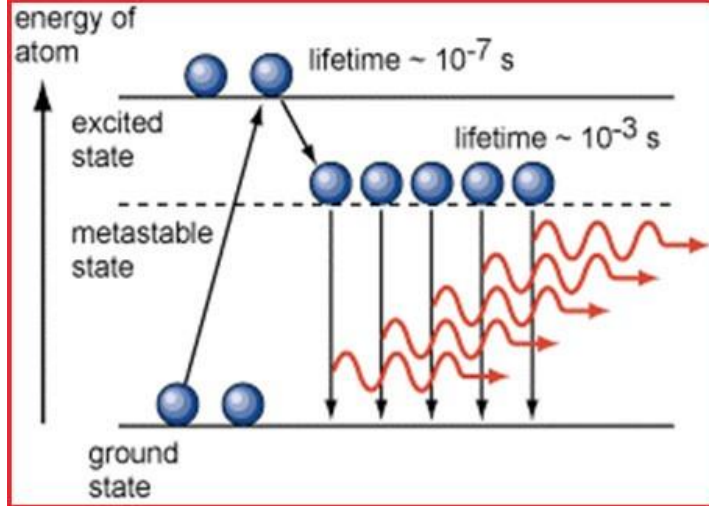

- الشرط الثاني فهو توفر مصدر يقوم بضخ الإلكترونات (**Pumping**) من المدارات منخفضة الطاقة (غير المثارة) إلى المدارات عالية الطاقة (المثارة) وذلك للحصول على التوزيع المقلوب للإلكترونات .
- الشرط الثالث فهو وجود نظام تغذية راجعة موجبة (**Positive feedback**) لكي يعمل الليزر كمذبذب (**Oscillator**) يقوم بتوليد تردد الضوء المطلوب وغالبا ما يتم استخدام المرايا (**Mirrors**) للحصول على هذه التغذية الراجعة .

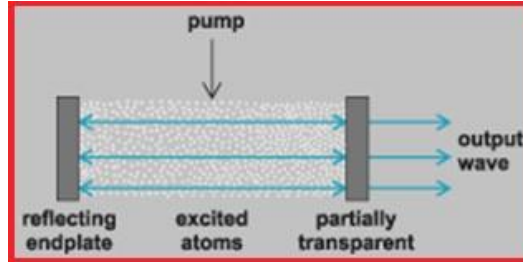

وعلى هذا فإن الليزر يعمل من خلال ضخ الإلكترونات باستخدام مصدر ضخ خارجي كالضوء أو التيار الكهربائي من المدار الأدنى إلى المدار الأعلى ومن ثم تهبط الإلكترونات المثارة من خلال الإنبعاث التلقائي من المدار الأعلى إلى المدار شبه المستقر (**metastable state**) والذي يقع بين المدارين الأدنى والأعلى حيث تبدأ الإلكترونات بالتراكم في هذا المدار لتنتج التوزيع الإسكاني المقلوب المنشود .

وإذا ما مر فوتون ضوئي بتردد محدد على المادة وهي في وضع التوزيع المقلوب فإنه سيحدث بعض الإلكترونات الموجودة في المدار شبه المستقر للنزول إلى المدار الأدنى منتجةً عدداً من الفوتونات الضوئية لها نفس تردد وطور واتجاه الفوتون الذي قام بحثها، أي أن الضوء المتولد سيكون له تردد واحد أي أنه أحادي اللون وذلك من الناحية النظرية.

وتستخدم المرايا لعكس بعض الفوتونات المتولدة لتمر من خال ذرات المادة الفعالة لتوليد مزيداً من الفوتونات التي لها نفس الخصائص. وعادةً ما تكون أحد المرايا ذات معامل انعكاس يقرب من الواحد وذلك لتعكس جميع الضوء الساقط عليها بينما يكون معامل انعكاس المرآة الثانية أقل من واحد وذلك لتسمح لجزء من الضوء المتولد للخروج منها لاستخدامه في التطبيقات المختلفة. وبما أن الفوتونات المستحثة لها نفس تردد الفوتونات التي قامت بحثها وتسير بنفس اتجاه سيرها فإن ضوء الليزر الناتج

سيكو

## Laser Physics

ن أحادي اللون تقريباً ويسير باتجاه واحد وذلك على العكس من طبيعة ضوء المصادر الأخرى. ويخرج الضوء المتولد من الليزر في العادة إما على شكل نبضات (pulsed laser) أو على شكل موجة مستمرة (continuous wave laser) والذي يحدد ذلك التركيب الذري للمادة الفعالة ونوع وكمية الضخ المستخدم وكذلك طريقة تركيب الليزر.

### تصنيف الليزر:

أ - استمرارية الإشعاع: مستمر (continuous) أو نبضي (pulsed)

فالليزر النبضي يصدر أشعته على شكل سلسلة من نبضات الضوء البالغة القصر. وتصدر هذه النبضات فقط عندما يكون الوسط الفعال في أعلى حالات الإثارة. وبعض أنواع أجهزة الليزر تصدر أشعتها بمعدل نبضة واحدة كل عدة دقائق. وهناك أنواع من الليزر مثل ليزر ثاني أكسيد الكربون، يمكن أن تكون موجاته نبضية أو مستمرة .

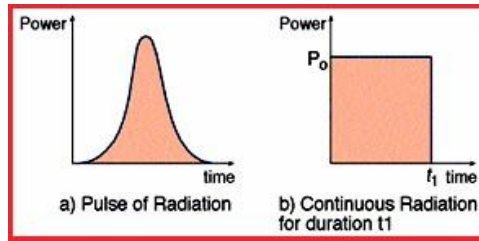

ب - تردد الإشعاع: الضوء المرئي، الأشعة فوق البنفسجية، الأشعة تحت الحمراء، ليزر أشعة اكس.

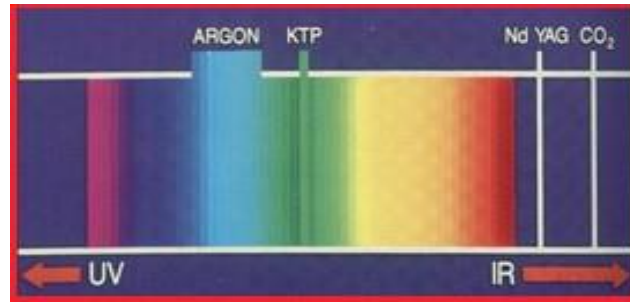

## The Interaction of Electromagnetic Radiation with Matter

### Emission and Absorption of Radiation

The interactions between electromagnetic radiation and matter cause changes in the energy states of the electrons in matter.

Electrons can be transferred from one energy level to another, while absorbing or emitting a certain amount of energy. This amount of energy is equal to the energy difference between these two energy levels ( $E_2 - E_1$ ).

When this energy is absorbed or emitted in a form of electromagnetic radiation, the energy difference between these two energy levels ( $E_2 - E_1$ )

d



etermines uniquely the frequency ( $\nu$ ) of the electromagnetic radiation:

$$(\Delta E) = E_2 - E_1 = h\nu$$

## Emission and Absorption of Radiation

Every system in nature "prefers" to be in the lowest energy state. This state is called the **Ground state**.

When energy is applied to a system, The atoms in the material are **excited**, and **raised to a higher energy level**.

(The terms "**excited atoms**", "**excited states**", and "**excited electrons**" are used here with no distinction)

**These electrons will remain in the excited state for a certain period of time, and then will return to lower energy states while emitting energy in the exact amount of the difference between the energy levels ( $\Delta E$ ).**

If this energy is transmitted as electromagnetic energy, it is called **photon**.

### Spontaneous Emission

The emission of the individual photon is random, being done individually by each excited atom, with no relation to photons emitted by other atoms.

When photons are randomly emitted from different atoms at different times, the process is called **Spontaneous Emission**. Since this emission is independent of external influence, there is **no preferred direction for different photons, and there is no phase relation between photons emitted by different atoms**.

**Spontaneous emission** is one of a family of processes, called **relaxation processes**, by which the **excited atoms return to equilibrium (ground state)**.

This "classic" explanation assumes that the specific frequencies emitted by an excited atom are the same as the characteristic frequencies of the atom, which means that **the emission spectrum is identical to the absorption spectrum**

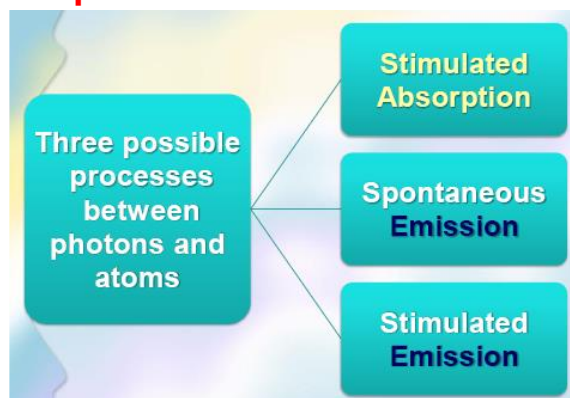

### Average Lifetime

Atoms stay in an excited level only for a short time (about  $10^{-8}$  [sec]), and the



## Laser Physics

they return to a lower energy level by spontaneous emission.

Every energy level has a **characteristic average lifetime**, which is the average time the electron exists in the excited state before making a spontaneous transition. Thus, this is the time in which the excited atoms returned to a lower energy level. According to the quantum theory, **the transition from one energy level to another is described by statistical probability.**

**The probability of transition from higher energy level to a lower one is inversely proportional to the lifetime of the higher energy level.**

When the transition probability is low for a specific transition, the lifetime of this energy level is longer (about  $10^{-3}$  sec), and this level becomes a "**meta-stable**" level. In this meta-stable level a large population of atoms can be assembled. As we shall see, this level can be a candidate for the lasing process.

When the population number of a higher energy level is bigger than the population number of a lower energy level, a condition of "**population inversion**" is established. If a **population inversion exists** between two energy levels, the probability is high that an incoming photon will **stimulate** an excited atom to return to a lower state, while emitting another photon of light. The probability for this process depends on the match between the energy of the incoming photon and the energy difference between these two levels.

مكونات جهاز الليزر:

يتكون أي جهاز مولد لشعاع الليزر مما يلي:

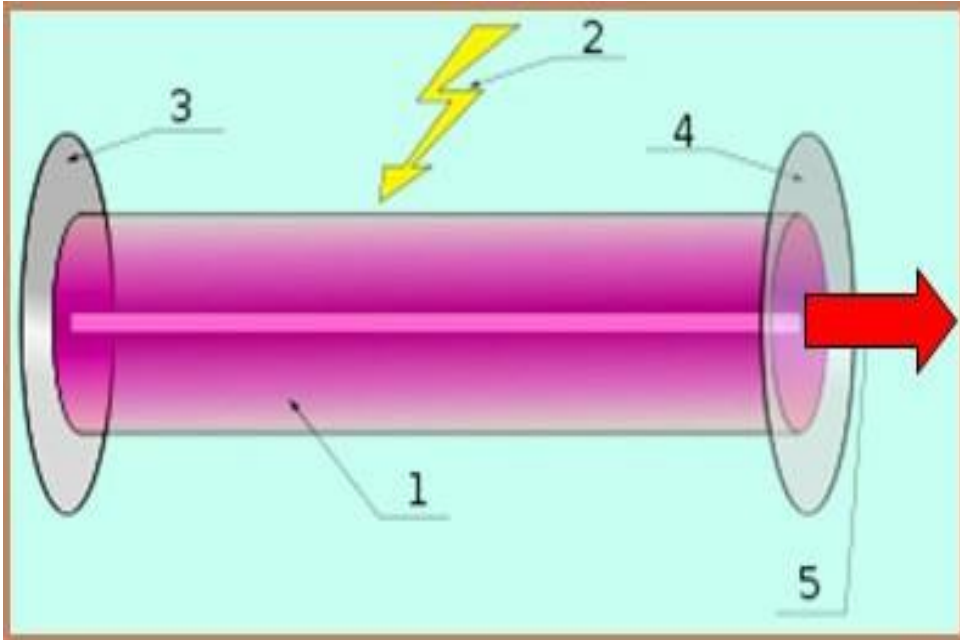

1 - الوسط الفعال. 2 - مصدر الضخ الإلكتروني. 3 - مرآة عاكسة مثالية. 4 - مرآة عاكسة جزئياً. 5 - مخرج شعاع الليزر.

**(الوسط الفعال active medium):**

وهو الوسط الذي تتولد منه الأشعة وقد يكون الوسط عبارة عن مجموعة من ذرات أو جزيئات أو عنصر أو مركب أو مزيج بحالة صلبة أو سائلة أو غازية له عدد من المستويات الطاقية تصلح لأن تتحقق بينها الانتقالات الثلاثة الضرورية (امتصاص, انبعاث تلقائي, انبعاث مستحث). يصنف الوسط الفعال اعتماداً على احتمالية الانتقال بين المستويات. بعض أنواع تلك المواد الفعالة ضوئياً وليزريراً: غاز نقي ( ذري) هيليوم – نيون مزيج غازي غاز الكربون CO<sub>2</sub>-مزيغ غازي (جزئي) بلورة الياقوت المطعم بالكروم صلب (بلورة) (الزجاج المنشط YAG صلب ( بلورة) أو أكسي كلور الفوسفور المشوب بالنيوديميوم (سائل).

**خطط الضخ:**

أي دراسة عن كيفية ضخ الوسط الفعال بطاقة من مصدر ما لتحقيق التأهيل العكسي بمقدار يتجاوز القيمة الحرجة للمستويين ويؤدي إلى إشعاع يتضخم عن طريق الانبعاث المحفز. إن هذا الهدف لا يمكن تحقيقه باستخدام نظام ذري ذو مستويين فقط للطاقة لأنه باستخدام إشعاع كهرومغناطيسي شديد ذو تردد مناسب مثلاً لعملية الضخ سرعان ما يولد حالة الأشباع عندها يتساوى تأهيل المستويين ذات العلاقة ويصبح الوسط شفافاً. لذلك يمكن العمل على ليزر ذي ثلاثة أو أربعة مستويات للطاقة:

**أ - نظام ليزر ثلاثي المستويات 3-Level Laser System**

أن مستويات الطاقة التي يحدث بينهما الفعل الليزري هما: المستوى الليزري السفلي (E1) والمستوي الليزري العلوي (E2)، للحصول على الليزر يجب أن تضخ كمية كبيرة من الطاقة للحصول على التعداد المعكوس بحيث يكون عدد الذرات في المستوى الثاني (E2) أكبر من عددها في المستوى الأرضي (E1). بما أن العمر الزمني (life time) للمستوى (E2) كبير نسبياً (~10<sup>-3</sup>sec) معظم الذرات تبقى في هذا المستوى، فإذا كانت طاقة الضخ كبيرة بما فيه الكفاية بحيث أنه أكثر من 50% من عدد الذرات تستقر في المستوى 2E فسوف نحصل على التعداد المعكوس ويحصل الفعل الليزري.

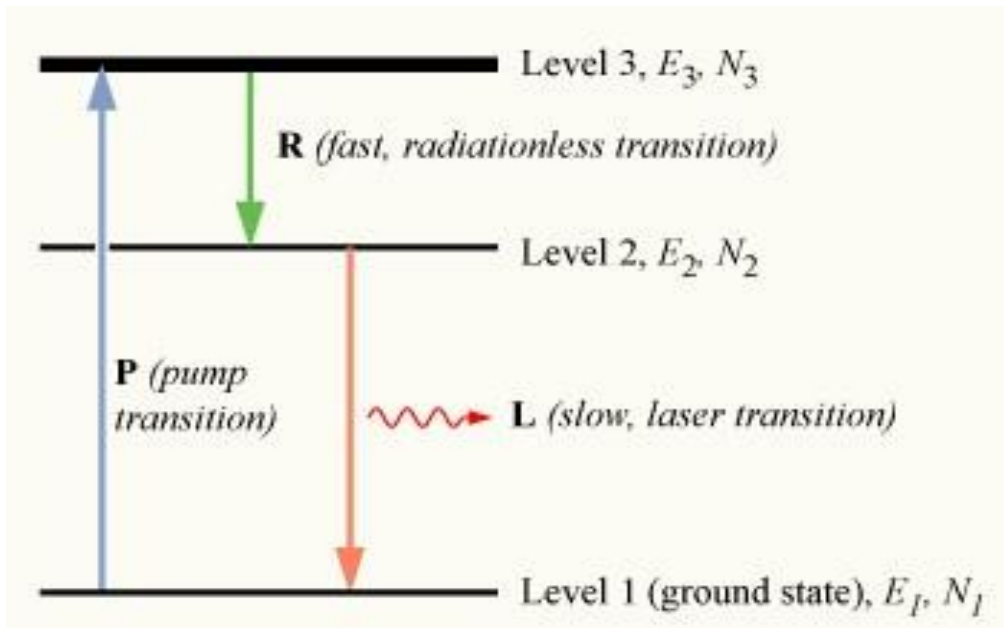

#### 4- Level Laser System

ب - نظام ليزر رباعي المستويات

بالمقارنة مع نظام ليزر ذي ثلاث مستويات هناك مستوى طاقة إضافي فوق المستوى الأرضي، وهذا المستوى الإضافي له عمر زمني قصير جداً.

إن عملية الضخ في نظام الأربع مستويات مشابهة إلى عملية الضخ في نظام الثلاث مستويات، وهذا يتم من خلال الحصول على التوزيع المعكوس للمستوى E3 من خلال الحصول على التوزيع المعكوس للمستوى E3 من خلال المستوى الطاقوي E4.

إن فائدة نظام المستويات الأربعة هو حقيقة أن تعداد المستوى الطاقوي E2 قليل، وللحصول على التعداد المعكوس ليس هناك حاجة لأن تكون أكثر من 50% من الذرات في المستوى الليزري العلوي.

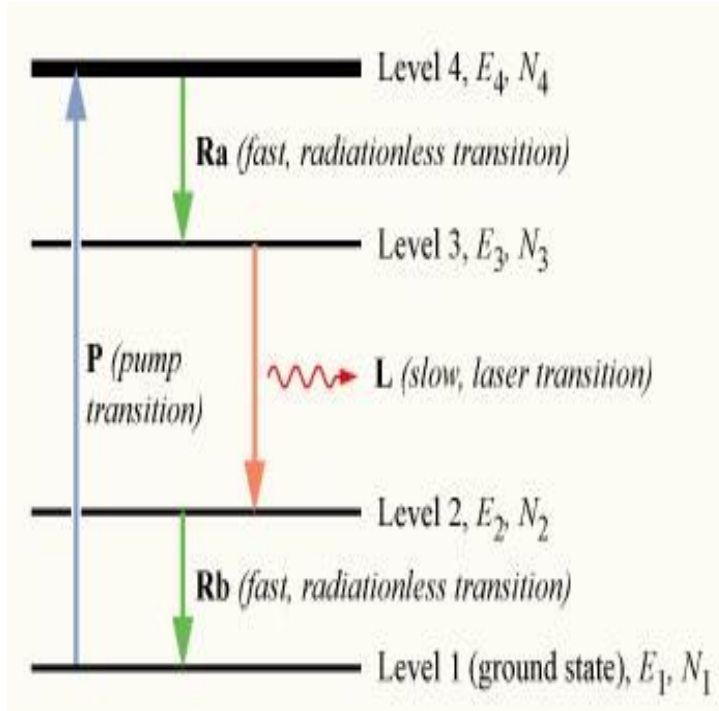

وبعد ذلك التعداد في المستوى الليزري السفلي  $2N$  سوف تضمحل بشكل سريع إلى المستوى الأرضي، لذا فهي تعد عملياً فارغة. لهذا السبب يمكن يكون من الممكن العمل بالنمط المستمر حتى ولو كان 99% من الذرات تبقى في المستوى الأرضي.

**مميزات ليزر الأربعة مستويات بالمقارنة مع نظام الثلاث مستويات:**

- ✓ حد العتبة للفعل الليزري في نظام المستويات الأربعة أقل
- ✓ الكفاءة تكون أعلى
- ✓ يحتاج إلى طاقة ضخ أقل
- ✓ يمكن العمل بالنمط المستمر

### 1.3. PUMPING SCHEMES

We will now consider the problem of how a population inversion can be produced in a given material. At first sight, it might seem that it would be possible to achieve this through the interaction of the material with a sufficiently strong e.m. wave, perhaps coming from a sufficiently intense lamp, at the frequency  $\nu = \nu_0$ . Since, at thermal equilibrium, one has  $g_1 N_1 > g_2 N_2$ , absorption will in fact predominate over stimulated emission. The incoming wave would produce more transitions  $1 \rightarrow 2$  than transitions  $2 \rightarrow 1$  and we would hope in this way to end up with a population inversion. We see immediately, however, that such a system would not work (at least in the steady state). When in fact the condition is reached such that  $g_2 N_2 = g_1 N_1$ , then the absorption and stimulated emission processes will compensate one another and, according to Eq. (1.2.1), the material will then become transparent. This situation is often referred to as two-level *saturation*.

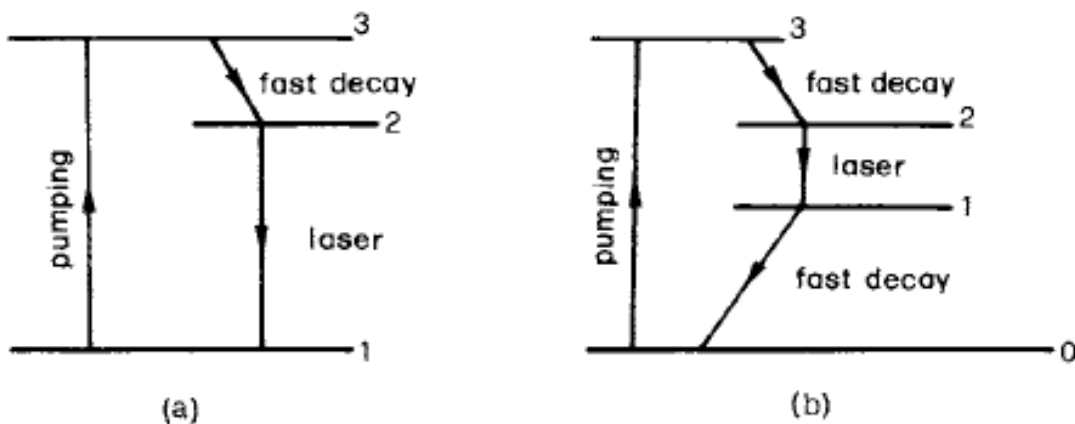

FIG. 1.4. (a) Three-level and (b) four-level laser schemes.

With just two levels, 1 and 2, it is therefore impossible to produce a population inversion. It is then natural to question whether this is possible using more than two levels out of the infinite set of levels of a given atomic system. As we shall see, the answer is in this case positive, and we will accordingly talk of a *three-level laser* or *four-level laser*, depending upon the number of levels used (Fig. 1.4). In a three-level laser (Fig. 1.4a), the atoms are in some way raised from the ground level 1 to level 3. If the material is such that, after an atom has been raised to level 3, it decays rapidly to level 2 (perhaps by a rapid nonradiative decay), then a population inversion can be obtained between levels 2 and 1. In a four-level laser (Fig. 1.4b), atoms are again raised from the ground level (for convenience we now call this level 0) to level 3. If the atom then decays rapidly to level 2 (e.g. again by a fast nonradiative decay), a population inversion can again be obtained between levels 2 and 1. Once oscillation starts in such a four-level laser, however, the atoms will then be transferred to level 1, through stimulated emission. For continuous wave (henceforth abbreviated as cw) operation it is therefore necessary that the transition  $1 \rightarrow 0$  should also be very fast (this again usually occurs by a fast nonradiative decay).

We have just seen how to make use of a three or four levels of a given material to produce population inversion. Whether a system will work in a three- or four-level scheme (or whether it will work at all!) depends on whether the various conditions given above are fulfilled. We could of course ask why one should bother with a four level scheme when a three-level scheme already seems to offer a suitable way of producing a population inversion. The answer is that one can, in general, produce a population inversion much more easily in a four-level than in a three-level laser. To see this, we begin by noting that the energy difference among the various levels of Fig. 1.4 are usually much greater than  $kT$ . According to Boltzmann statistics [see, e.g., Eq. (1.2.2)] we can then say that essentially all atoms are initially (i.e., at equilibrium) in the ground level. If we now let  $N_i$  be the atom density in the material, these will initially all be in level 1 from the three-level case. Let us now begin raising atoms from level 1 to level 3.

They will then decay to level 2 and, if this decay is sufficiently fast, level 3 will remain more or less empty. Let us now assume, for simplicity, that the two levels are either non-degenerate (i.e.  $g_1 = g_2 = 1$ ) or have the same degeneracy. Then, according to Eq. (1.2.1), the absorption losses will be compensated by the gain when  $N_2 = N_1$ . From this point on, any further atom that is raised will then contribute to population inversion. In a four-level laser, however, since level 1 is also empty, any atom that has been raised to level 2 immediately produces population inversion. The above discussion shows that, whenever possible, we should look for a material that can be operated as a four-level rather than a three-level system. The use of more than four levels is, of course, also possible. It should be noted that the term “four-level laser” has come to be used for any laser in which the lower laser level is essentially empty, by virtue of being above the ground level by many  $kT$ . So if level 2 and level 3 are the same level, then one has a level scheme which would be described as “four-level” in the sense above, while only having three levels! Cases based on such a “four-level” scheme do exist. It should also be noted that, more recently, the so-called *quasi-three-level lasers* have also become a very important category of laser. In this case, the ground level consists of many sublevels, the lower laser level being one of these sublevels. Therefore, the scheme of Fig. 1.4b can still be applied to a quasi-three-level laser with the understanding that level 1 is a sublevel of the ground level and level 0 is the lowest sublevel of the ground level. If all ground state sublevels are strongly coupled, perhaps by some fast non-radiative decay process, then the populations of these sublevels will always be in thermal equilibrium. Let us further assume that the energy separation between level 1 and level 0 (see Fig. 1.4b) is comparable to  $kT$ . Then, according to Eq. (1.2.2), there will always be some population present in the lower laser level and the laser system will behave in a way which is intermediate between a three- and a four-level laser.



The process by which atoms are raised from level 1 to level 3 (in a three-level scheme), from 0 to 3 (in a four-level scheme), or from the ground level to level 3 (in a quasi-three-level scheme) is known as *pumping*. There are several ways in which this process can be realized in practice, e.g., by some sort of lamp of sufficient intensity or by an electrical discharge in the active medium. We refer to Chap. 6 for a more detailed discussion of the various pumping processes. We note here, however, that, if the upper pump level is empty, the rate at which the upper laser level becomes populated by the pumping,  $(dN_2/dt)_p$ , can in general be written as  $(dN_2/dt)_p = W_p N_g$  where  $W_p$  is a suitable rate describing the pumping process and  $N_g$  is the population of the ground level for either a three- or four-level laser while, for a quasi-three-level laser, it can be taken to be the total population of all ground state sublevels. In what follows, however, we will concentrate our discussion mostly on four level or quasi-three-level lasers. The most important case of three-level laser, in fact, is the Ruby laser, a historically important laser (it was the first laser ever made to operate) although no longer so widely used. For most four-level and quasi-three-level lasers in common use, the depletion of the ground level, due to the pumping process, can be neglected.\* One can then write  $N_g = \text{const}$  and the previous equation can be written, more simply, as

$$(dN_2/dt)_p = R_p \tag{1.3.1}$$

where  $R_p$  may be called the pump rate per unit volume or, more briefly, the *pump rate*. To achieve the threshold condition, the pump rate must reach a threshold or critical value,  $R_{cp}$ . Specific expressions for  $R_{cp}$  will be obtained in Chap. 6 and Chap. 7.

## Chapter 3

# General Description of LASER and LASER OPERATION

## LASER OPERATION

A laser is a device that emits a narrow beam of single-wavelength, coherent light as a result of stimulated emission. The term laser began as an acronym for “Light Amplification by Stimulated Emission of Radiation.” The output power of laser light can vary from a few thousandths of a watt (in the case of laser pointers) to several thousand watts (industrial laser cutters). Every laser contains an active medium, which is the source of atoms that will undergo cycles of excitation and de-excitation to release photons that will form the laser beam. Depending on the type of laser, the active medium can be a solid, liquid, or gas. Let’s walk through the necessary conditions for laser operation, all of which build upon the principles of energy levels, excitation, fluorescence, and phosphorescence that we covered earlier in this section.

## Stimulated Emission

We have previously discussed how an atom can become excited from a lower to a higher energy level by absorbing a photon with energy equal to the difference between the energies of two levels. Eventually, the atom will return to a lower energy state by emitting a photon in a process known as spontaneous emission. Although we can predict on average how long it will take for de-excitation to occur (i.e., the lifetime of the state), it’s impossible to predict exactly when a specific excited atom will spontaneously emit a photon. Furthermore, the direction of the emitted photon is also random. Atoms can also transition to a lower energy level through a process called stimulated emission. While an atom is in an excited state, the oscillating electric field from a passing photon (at the same frequency as—or very close to—the transition frequency of the excited electron) can cause the atom to emit a second photon that oscillates in precise synchrony with the first (FIGURE ). Most significantly, the emitted photon is identical in frequency, phase, and direction to the first photon. These identical photons are what make up a laser beam



## Population Inversion

A functional laser depends on not just a handful of stimulated emission events, but rather a full cascade that will continually generate a stream of stimulated emission photons. When a collection of atoms is in thermodynamic equilibrium (that is, it is not exchanging energy with its surroundings), the vast majority of the atoms tend to be in the lowest possible energy state. This poses a problem because an emitted photon is almost certain to be absorbed by an atom in the ground state instead of stimulating emission in an excited atom.

Clearly, in order to sustain the chain reaction of stimulated emission events, the atoms must be prepared such that more are in an excited state than are in the ground state. This condition is known as population inversion (FIGURE 57). Stimulated emission will continue as long as population inversion exists within the active medium, but it will slow down and eventually stop if a majority of the atoms are no longer in the higher-energy state.

Fig: A population inversion exists when more atoms are in an excited state than in the ground state.

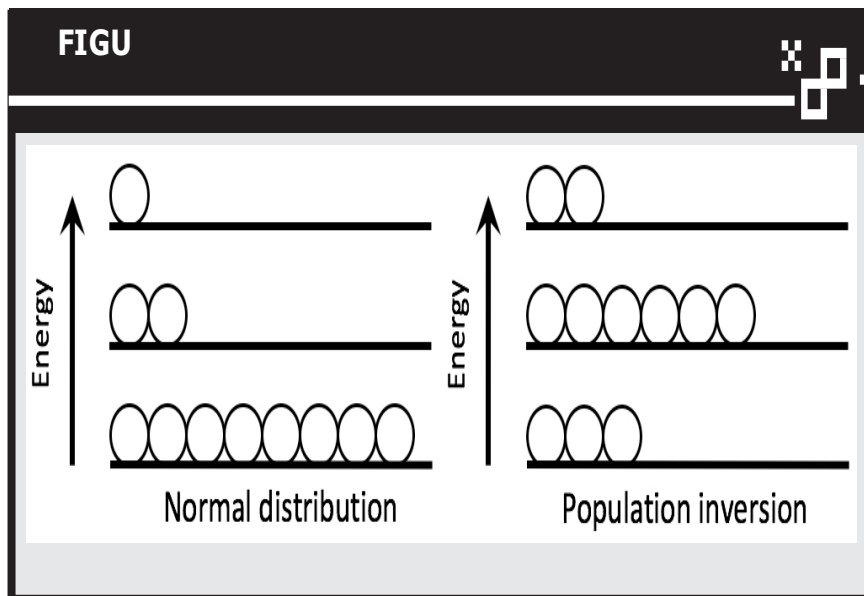

**Photon Absorption:** A photon with frequency  $\nu_{12}$  hits an atom at rest (left), and excites it to higher energy level ( $E_2$ ) while the **photon is absorbed**.

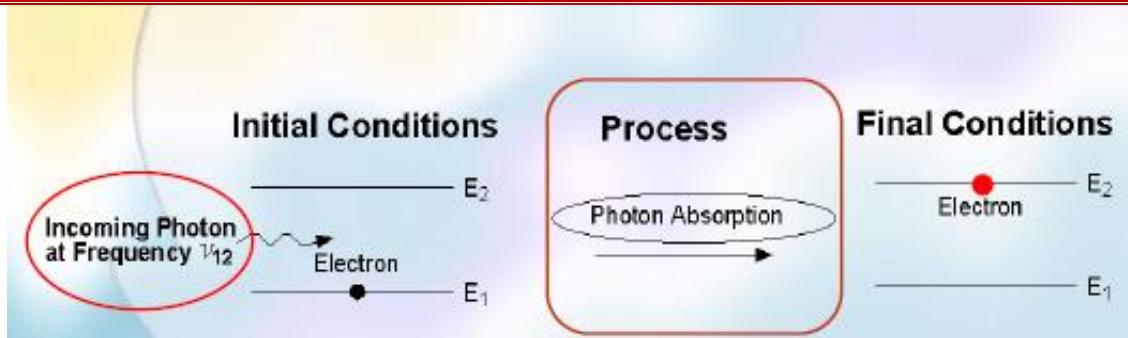

## Spontaneous Emission

**Spontaneous emission of a photon:** An atom in an excited state (left) emits a photon with frequency  $\nu_{12}$  and goes to a lower energy level ( $E_1$ ).

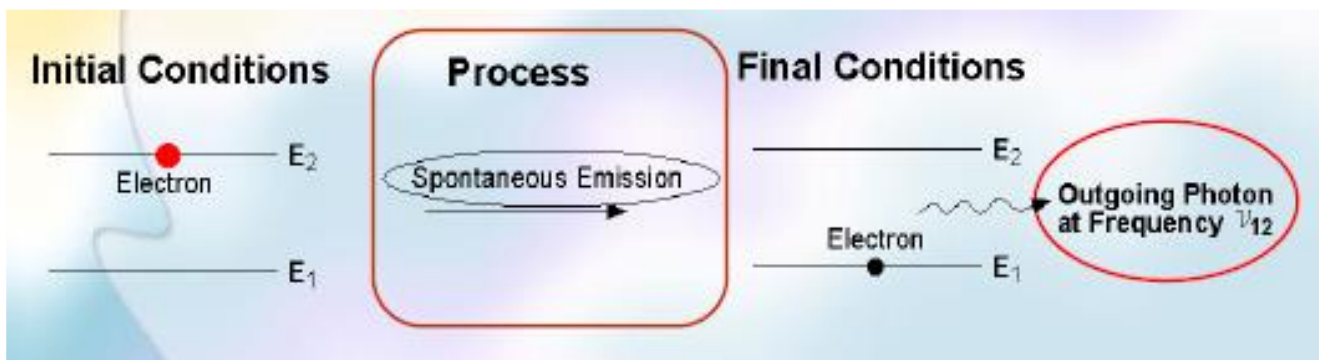

## Stimulated Emission

**Stimulated emission of a photon:** A photon with frequency  $\nu_{12}$  hit an excited atom (left), and cause emission of two photons with frequency  $\nu_{12}$  while the atom goes to a lower energy level ( $E_1$ ).

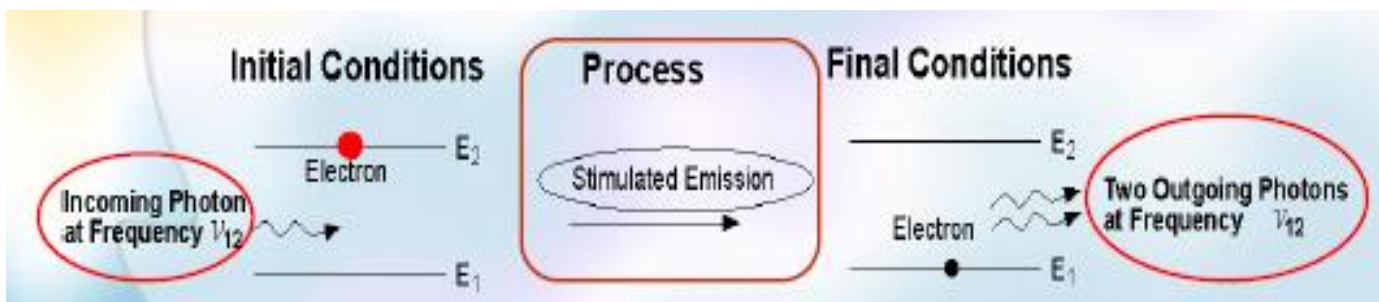

## Stimulated Absorption

We saw that the process of **photon absorption** by the atom is a process of raising the atom (electron) from a lower energy level into a higher energy level (excited state), by an amount of energy which is equivalent to the energy of the absorbed photon.

## Stimulated Emission

The incoming photon is an **electromagnetic field** which is oscillating in time and space. This field forces the excited atom to oscillate with the same frequency and phase as the applied force, which means that the atom can not oscillate freely, but is **forced to oscillate coherently with the incoming photon**. Remember that **two photons with the same wavelength (frequency) have the same energy**:

$$E = h\nu = hc/\lambda$$

**The incoming photon does not change at all as a result of the stimulated emission process.** As a result of the stimulated emission process, we have **two identical photons created from one photon** and one excited state. Thus we have **amplification** in the sense that the number of photons has increased.

ground state is unlimited. On the other hand, the particle can remain in the excited state for a limited time known as *life time*. The life time of the

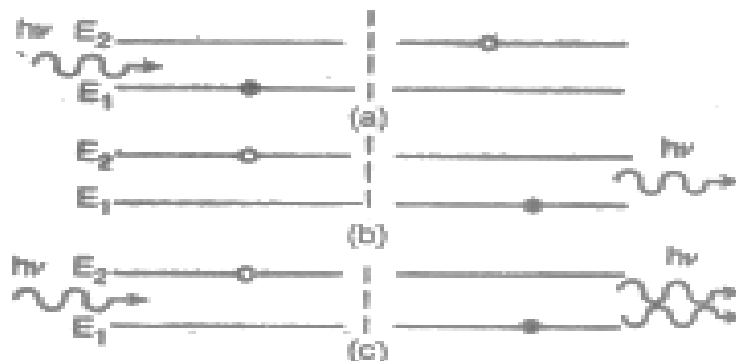

Fig. (1) Excitation and emission of a particle.

excited hydrogen atom is of the order of  $10^{-8}$  sec. However, there exist such excited states in which the life time is greater than  $10^{-8}$  sec. These states are called as *metastable*. Here two points should be remembered. (1) Only certain transitions are possible which are allowed by selection rules. (2) The transition of a particle from one energy state to another can be non-radiative. In such cases the energy is transmitted to other particles which is converted into heat. After being in the excited state, the particle returns to the ground state. The probability of transition to the ground state with emission of radiation is made up of two factors, one constant and the other variable.

#### Spontaneous emission :

The excited atom does not remain in that state for a long time. After a short interval of time  $10^{-8}$  sec. It falls to its lower energy state by emitting a photon as shown in fig. (1b). Here the excited atom jumps back to its ground state on its own accord and hence the process is known as *spontaneous emission*. So the emission which takes place without external incitement is called *spontaneous emission*. The spontaneous emission depends on the type of the particle and type of transition but is independent of outside circumstances. The spontaneous emission (not caused by an extraneous effects) is random in character. The radiation in this case is a random mixture of quanta having various wavelengths. The waves coincide neither in wavelength nor in phase. Thus the radiation is *incoherent* and has a broad spectrum.

#### Stimulated emission :

Suppose an atom is already in the excited state of energy level  $E_2$  whose ground level energy is  $E_1$ . If at this moment, a photon of energy

$h\nu = E_2 - E_1$  is incident on the excited atom, the incident photon stimulates the emission of a similar photon from the excited atom. Now the atom returns to the ground state. The transition takes place much sooner than  $10^{-8}$  sec. The process of speeding up the atomic transition from the excited state to lower state is called *stimulated emission*. The stimulated emission is proportional to the intensity of the incident light. This is shown in fig. (1 c). The remarkable feature of the stimulated emission is that it is *coherent* with the stimulating incident radiation. It has the same frequency and phase as the incident radiation.

So, the stimulated emission takes place when a photon of right frequency interacts with an excited atom and forces it to emit another photon of the same frequency in same direction and in same phase. As a result, a large number of photons are emitted. They form the source of *intense, coherent and monochromatic light i.e., laser*

In an ordinary source of light, the spontaneous emission dominates.

### 7-3. DISTINCTION BETWEEN SPONTANEOUS AND STIMULATED EMISSION

The distinction between spontaneous and stimulated emission is as follows :

Spontaneous emission	Stimulated emission
1. Transition occurs from a higher energy level to a lower energy level.	Transition also occurs from higher energy level to lower energy level.
2. No incident photon is required.	Photon whose energy is equal to the difference of two energy levels is required.
3. Single photon is emitted.	Two photons with same energy are emitted.
4. The energy of emitted photon is equal to the energy difference of two levels.	The energy of the emitted photons is double the energy of stimulated photons.
5. This was postulated by Bohr.	This was postulated by Einstein.

### 7-4. EINSTEIN COEFFICIENTS

In article 7-2 we have studied the processes of absorption, spontaneous emission and stimulated emission.

(1). The probable rate of occurrence of the *absorption transition* from state 1 to state 2 [see. fig. 2a] depends on the properties of states 1 and 2 and is proportional to energy density  $u(\nu)$  of the radiation of frequency  $\nu$  incident on the atom. Thus



Fig. (2a)

$$P_{12} \propto u(\nu) \text{ or } P_{12} = B_{12} u(\nu) \quad \dots(1)$$

The proportionality constant  $B_{12}$  is known as '*Einstein's coefficient of absorption of radiation*'.

(2). The probability of spontaneous emission from state 2 to state 1 [see. fig. 2b] depends only on the properties of states 1 and 2. This is independent of energy density  $u(\nu)$  of incident radiation. Einstein denoted this probability per unit time by  $A_{21}$ .



Fig. (2b)

$$\therefore (P_{21})_{\text{spontaneous}} = A_{21}$$

$A_{21}$  is known as '*Einstein's coefficient of spontaneous emission of radiation*'.

Here it should be noted that the probability of absorption transition depends upon energy density  $u(\nu)$  of incident radiation whereas the probability of spontaneous emission is independent of it. Hence for equilibrium, emission transition depending upon  $u(\nu)$  must also exist. Actually these transitions are stimulated emission transitions.

(3). The probability of stimulated emission transition from state 2 to



Fig. (2c)

state 1 [see. fig. 2 c] is proportional to the energy density  $u(\nu)$  of the stimulating radiation i.e.,

$$(P_{21})_{\text{stimulated}} = B_{21} u(\nu)$$

where  $B_{21}$  is '*Einstein's coefficient of stimulated emission of radiation*'.

The total probability for an atom in state 2 to drop to the lower state 1 is, therefore

$$P_{21} = A_{21} + B_{21} u(\nu) \quad \dots(2)$$



### 7.5. RELATION BETWEEN EINSTEIN'S A AND B COEFFICIENTS.

Consider an assembly of atoms in thermal equilibrium at temperature  $T$  with radiation of frequency  $\nu$  and energy density  $u(\nu)$ . Let  $N_1$  and  $N_2$  be the number of atoms in energy states 1 and 2 respectively at any instant.

The number of atoms in state 1 that absorb a photon and rise to state 2 per unit time is given by

$$N_1 P_{12} = N_1 B_{12} u(\nu) \quad \dots(3)$$

The number of photons in state 2 that can cause emission process [spontaneous + stimulated] per unit time is given by

$$N_2 P_{21} = N_2 [A_{21} + B_{21} u(\nu)] \quad \dots(4)$$

For equilibrium, the absorption and emission must occur equally, hence

$$\begin{aligned} N_1 P_{12} &= N_2 P_{21} \\ N_1 B_{12} u(\nu) &= N_2 [A_{21} + B_{21} u(\nu)] \\ \text{or } N_1 B_{12} u(\nu) &= N_2 A_{21} + N_2 B_{21} u(\nu) \\ \text{or } u(\nu) [N_1 B_{12} - N_2 B_{21}] &= N_2 A_{21} \\ \therefore u(\nu) &= \frac{N_2 A_{21}}{N_1 B_{12} - N_2 B_{21}} = \frac{A_{21}}{B_{21}} \frac{1}{\left[ \frac{N_1}{N_2} \left( \frac{B_{12}}{B_{21}} \right) - 1 \right]} \quad \dots(5) \end{aligned}$$

According to Boltzmann distribution law, the number of atoms  $N_1$  and  $N_2$  in energy states  $E_1$  and  $E_2$  in thermal equilibrium at temperature  $T$  is given by

$$N_1 = N_0 e^{-E_1/kT} \quad \text{and} \quad N_2 = N_0 e^{-E_2/kT}$$

where  $N_0$  = total number of atoms present and  $k$  = Boltzmann's constant

$$\begin{aligned} \therefore \frac{N_2}{N_1} &= \frac{e^{-E_2/kT}}{e^{-E_1/kT}} = e^{-(E_2 - E_1)/kT} = e^{-h\nu/kT} \\ \text{or } \frac{N_1}{N_2} &= e^{h\nu/kT} \quad \dots(6) \end{aligned}$$

Substituting the value of  $N_1/N_2$  from eq. (6) in eq. (5), we get

$$u(\nu) = \frac{A_{21}}{B_{21}} \frac{1}{\left[ e^{h\nu/kT} \left( \frac{B_{12}}{B_{21}} \right) - 1 \right]} \quad \dots(7)$$

According to Planck's radiation formula

$$u(\nu) = \frac{8\pi h \nu^3}{c^3} \cdot \frac{1}{[e^{h\nu/kT} - 1]} \quad \dots(8)$$

Comparing eqs. (7) and (8), we get

$$\frac{A_{21}}{B_{21}} = \frac{8\pi h \nu^3}{c^3} \quad \text{and} \quad \frac{B_{12}}{B_{21}} = 1 \quad \text{or} \quad B_{12} = B_{21}$$

Hence

(i) As  $B_{12} = B_{21}$ , the probability of stimulated emission is same as induced absorption.

(ii)  $A_{21}/B_{21} \propto \nu^3$  i.e., the ratio of spontaneous emission and stimulated emission is proportional to  $\nu^3$ . This shows that the probability of spontaneous emission increases rapidly with energy difference between two states.

### 7.6. LASING ACTION :

In stimulated emission, the emitted photon travels in the same direction as that of incident photon [Fig. (3a)]. Now the two photons again stimulate emission of photon from two excited atoms. This results in the emission of four photons from the two excited atoms [Fig. (3b)]. In

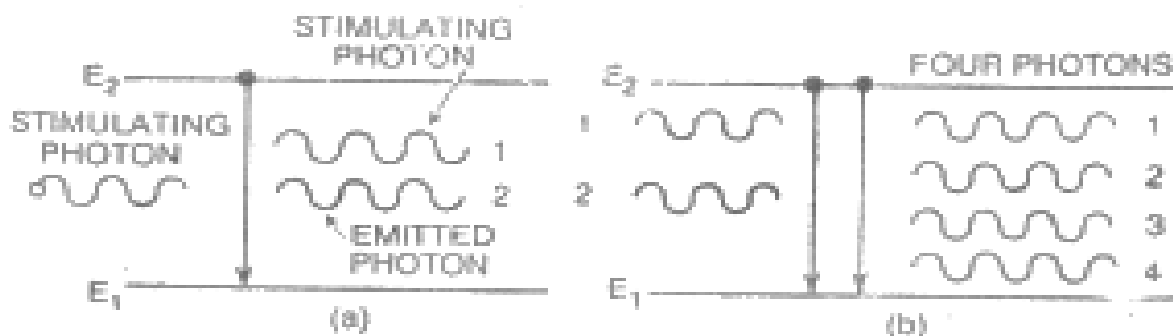
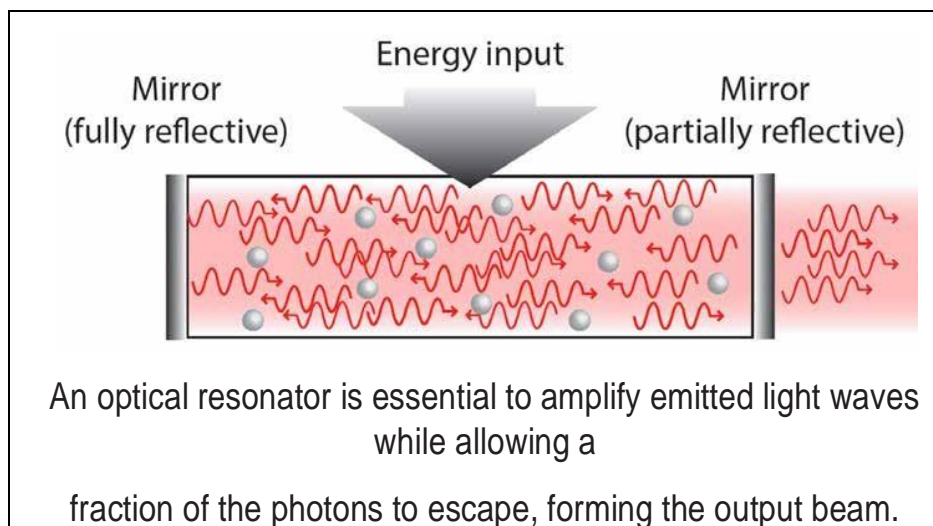

Fig. (3).

a similar way a *chain reaction* or *avalanche effect* is produced. The phenomenon is known as *lasing action*. So a *monochromatic, intense and coherent beam* having the same frequency as that of incident beam is obtained. This is called laser beam. This is the principle of working of a laser.

## Optical Cavity

Once population inversion is achieved (i.e., most of the atoms are in an excited state), a single atom undergoing de-excitation emits a photon that causes a chain reaction of stimulated emission events: that photon causes stimulated emission in a nearby atom, which emits an identical photon, which stimulates the emission of another photon, and so on. In order to sustain the chain of stimulated emission events and amplify the laser beam, the active medium must be surrounded by an optical cavity (also known as a laser cavity or optical resonator). The simplest optical cavity consists of two parallel mirrors, one of which is slightly transmitting to allow the output of the laser beam. One mirror is coated to be completely reflective (100 percent chance of reflection) whereas the other is coated to be partially reflective (~95 percent chance of reflection). Photons that “leak” from the partially reflective mirror form the laser beam. It’s possible for light to reflect back and forth several hundred times before exiting the resonator ( ).



### THE RESONATOR

Although with a population inversion we have the ability to amplify a signal via stimulated emission, the overall single-pass gain is quite small, and most of the excited atoms in the population emit spontaneously and do not contribute to the overall output. To turn this system into a laser, we need a positive feedback mechanism that will cause the majority of the atoms in the population to contribute to the coherent output. This is the resonator, a system of mirrors that reflects undesirable (off-axis) photons out of the system and reflects the desirable (on-axis) photons back into the excited population where they can continue to be amplified.

### **TYPES OF LASERS**

#### **Gas Lasers**

Gas lasers use a low-pressure gas mixture as an active medium. Most gas lasers are excited by passing an electric current through the gas, delivered by electrodes placed at opposite ends of the tube. The helium-neon laser (or HeNe laser) is a common gas laser that produces light in the visible spectrum at a wavelength of 632.8 nm. HeNe laser cavities contain a mixture of helium and neon gas. The helium atoms are excited by an applied current and then collide with neon atoms to excite them to the state that causes the 632.8 nm radiation. The bright red output and relatively low cost of HeNe lasers make them well suited for many low-power applications in educational and research laboratories

Other examples of gas lasers include the carbon dioxide (CO<sub>2</sub>) laser, which is a high-efficiency laser that operates in the infrared band. Carbon dioxide lasers are commonly used for high-power industrial applications such as welding and cutting.

Excimer lasers are a type of gas laser that rely on the excitation of “dimer” molecules, such as argon fluoride, that are stable only in the excited state. Excimer lasers were first demonstrated in the mid-1970s and are capable of removing extremely fine layers of surface material by breaking molecular bonds without burning or heating the surrounding area. For this reason, excimer lasers are well-suited for precision etching of plastics or semiconductor circuits, as well as delicate eye surgery such as LASIK.

An advantage of gas lasers over other laser types is that the gas medium tends to be both relatively inexpensive and largely resistant to damage. However, gas lasers are also typically larger than other types due to the low density of the medium. In recent years, gas lasers have seen a decline in sales as they have gradually been replaced by solid-state and semiconductor lasers for many commercial applications. For example, HeNe lasers were originally used in grocery store checkout scanners, but have largely been replaced by laser diodes for this purpose.

#### **Solid-State Lasers**

Solid-state lasers use an active medium consisting of a solid crystalline or glass rod (known as the host) containing light-emitting atoms (the active species). The first laser ever built was a solid-state laser using synthetic ruby, which is corundum (aluminum oxide crystal) with chromium as an active species. In most solid-state laser materials, the active species is identified first (typically by its chemical symbol), followed by the host material. For example, the Ti:sapphire laser consists of titanium atoms in sapphire crystal. Both the

active species and the host are important in solid-state lasers. The active species determines the laser transition, but its interactions with the host may shift the wavelength slightly. Neodymium (Nd) is commonly used as an active species in solid-state laser crystals. For example, the

Nd:YAG (neodymium-yttrium aluminum garnet) is one of the most common types of laser, with applications in research, medicine, manufacturing, and other fields ( ).

Nd:YAG lasers typically emit infrared light with a wavelength of 1064 nm although other wavelengths are possible. Other host materials for neodymium include YLF (yttrium lithium fluoride) and glass. The host material is selected based on its optical, thermal, and mechanical properties.

### **Semiconductor Diode Lasers**

Semiconductor diode lasers, commonly known as laser diodes, operate using the same basic principles as light-emitting diodes, but with some important differences. Like an LED, a laser diode consists of two semiconductor layers, an n-type with an excess of electrons and a p-type with electron “holes” to be filled. The semiconductor layers are separated by a microscopic region called the active layer that serves as the optical resonator. Laser diodes operate at much higher currents than LEDs, typically around ten times greater. Whereas an LED emits photons in all directions from its junction layer, a laser diode is configured with reflective ends to form an optical resonator in the region between the semiconductor layers. In a laser diode, stimulated emission occurs when a photon emitted by one electron transition triggers another electron to fill a hole, and so on, resulting in a coherent beam of light that emerges from one side of the diode.

Laser diodes are compact and easy to mass-produce. In terms of sheer numbers, they are the most common type of laser. Their small size makes them well suited for use in low-power applications such as laser pointers, laser printers, and CD/DVD players (FIGURE 64). Laser diodes can also be operated at lower voltages than other types of lasers. While gas and solid-state lasers require input voltages on the order of kilovolts, laser diodes can be operated at only a few volts.

Laser diodes are typically not as collimated as beams from other types of lasers. In many cases, an external lens is used to correct the shape of the beam, which contributes to the overall fragility of the laser since damage to the lens could render it non-functional. Furthermore, the delicate nature of the semiconductors makes laser diodes more sensitive to static discharges and currents. Excess electrical current can cause the diode to become inoperable. Laser diodes can also degrade in power efficiency over time, gradually requiring more power to output the same beam intensity.

## Common Features of Lasers

### 1- Light amplifying media



- All lasers contain an **amplifying substance** that works to *increase the intensity of light passing through it*
- This substance is called the **amplifying (or the gain) medium**.
- It can be a **solid (solid state laser)**, a **liquid (liquid laser)** or a **gas (gas laser)**.
- It contains atoms, molecules or ions in a high proportion to: *store energy which is subsequently released as light.*

### ***Amplifying medium is characterized by:***

**GAIN**



**the factor by which the intensity of the light is increased by the amplifying medium**

### **IT DEPENDS ON:**

- ❖ wavelength of the incoming light
- ❖ intensity of the incoming light
- ❖ length of the amplifying medium (inverse proportionality)
- ❖ amount of energizing the amplifying medium (pumping)



## 2- Energizing Amplifying Medium (Pumping)

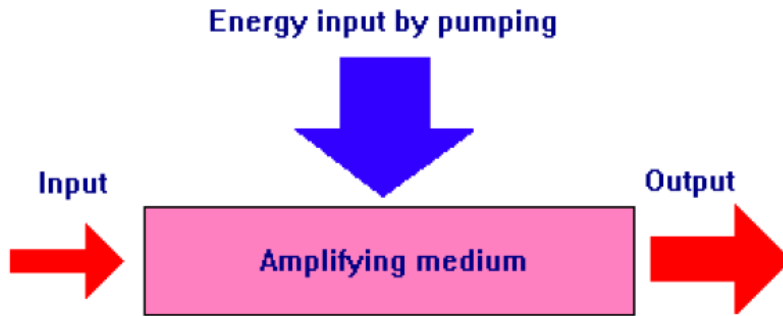

Amplifying a beam of light means putting additional energy into the beam.

**THEREFORE**

the amplifying medium must have energy fed into it to provide this energy

The fed energy works to **re-arranges the amplifying medium**  
**in some way to**  
**store the energy and then releases it as amplified light**

This process is known as **"pumping"**.

### Examples of Pumping

#### Optical pumping

- ❖ Xenon-filled flashtubes around a solid state amplifying medium
- ❖ High voltage causes electric discharge through the flash tube

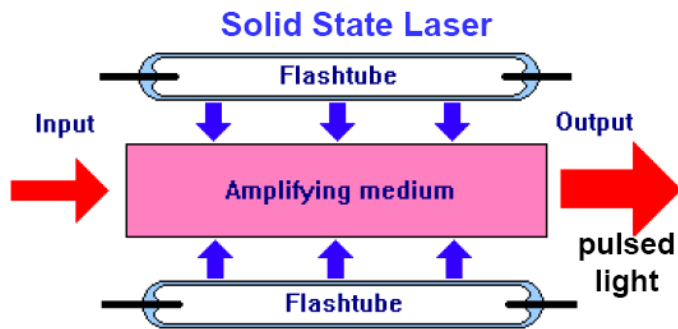

#### Electrical pumping

electric current passes across the junction of the diode

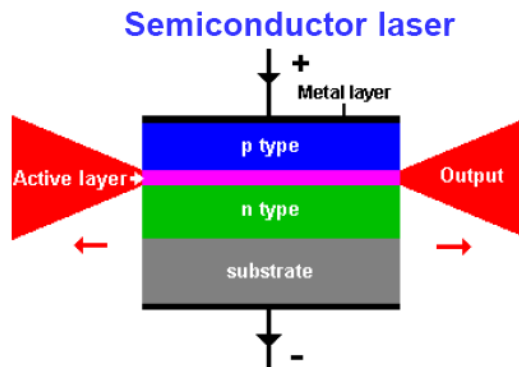

## 3- Laser Oscillator

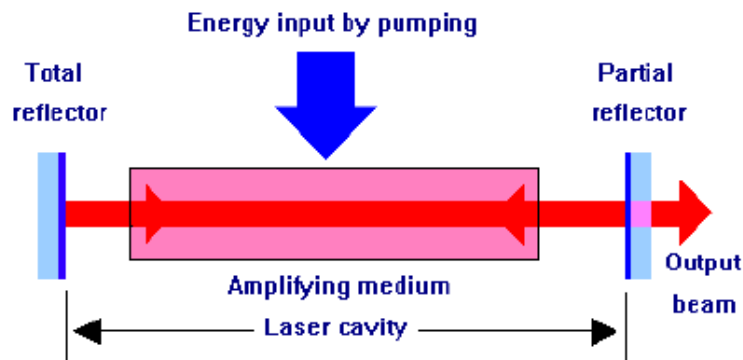

The pumped amplifying medium is positioned between **two mirrors**

'positive feedback'

some of the light that emerges from the amplifying medium is reflected back into it for further amplification.

An amplifier with positive feedback is known as an oscillator

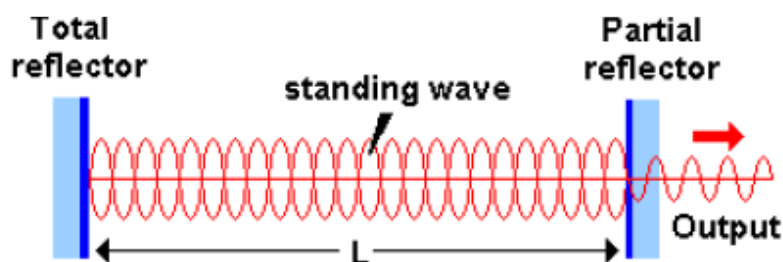

- The space between the two mirrors is known as **the laser cavity**
  - Within the cavity, the beam undergoes multiple reflections and is amplified each time it passes through the amplifying medium
  - One of the mirrors reflects almost all of the light that falls upon it
  - The other mirror reflects between 20% and 98% of the incident light.
  - This transmitted portion constitutes the output beam of the laser
- ❖ Light forms standing waves between the mirrors.
  - ❖ These waves correspond to longitudinal modes.
  - ❖ **Each mode:**
    - has a characteristic wavelength
    - propagates in a characteristic direction

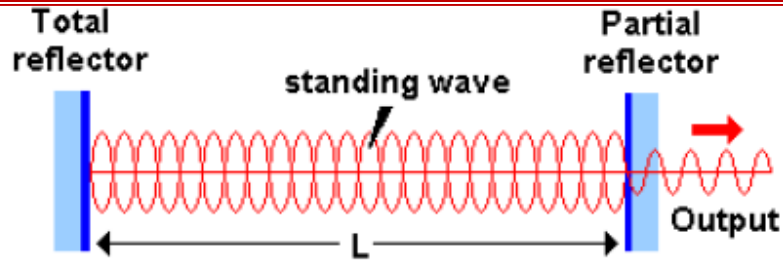

The number of modes  $m$  is:

$$L = m \frac{\lambda}{2n}, \text{ in which } m \text{ is an integer}$$

$$\lambda = \frac{1}{m} 2nL, \text{ mode wavelength}$$

$$\nu = \frac{c}{\lambda} = m \frac{c}{2nL}, \text{ mode frequency}$$

$$\Delta\nu = \nu_{m+1} - \nu_m = \frac{c}{2nL} (m+1 - m)$$

$$= \frac{c}{2nL} \text{ frequency separation between modes}$$

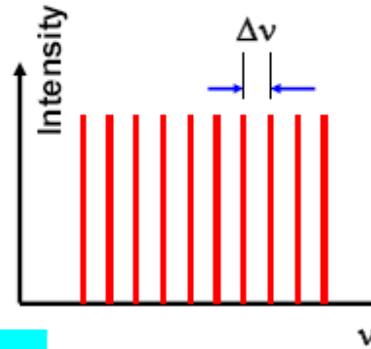

**When the resonator is occupied by the amplifying medium:**

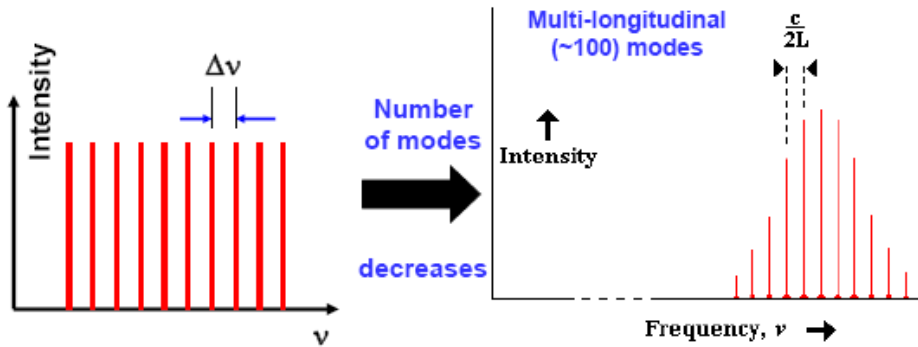

Example: for  $L = 50 \text{ cm}$ ,  $\frac{c}{2L} = 3 \times 10^8 \text{ Hz}$

Laser is not pure monochromatic source of light

**BUT**

- $\Delta\nu$  is very small compared to the frequency of light in the visible region
- compared to a conventional thermal light source, the output of lasers would still be regarded monochromatic.

Many techniques are developed to make laser oscillating in a single mode

## Example

A ruby laser contains a crystal length 4 cm with a refractive index of 1.78. The peak emission wavelength from the device is 0.55  $\mu\text{m}$ . Determine the number of longitudinal modes and their frequency separation?

## Solution

The number of modes is determined from the above relations as:

$$m = \frac{2nL}{\lambda} = \frac{2 \times 1.78 \times 0.04}{0.55 \times 10^{-6}} = 2.6 \times 10^5$$

and the frequency separation is

$$\Delta\nu = \frac{3 \times 10^8}{2 \times 1.78 \times 0.04} = 2.1 \text{ GHz}$$

## Lasing process and advantages of employing the laser cavity

- Following pumping, spontaneous emission occurs by excited atoms
- This emitted light initiates stimulated emission and then increases in intensity by multiple passes through the amplifying medium.

### ADVANTAGES OF THE CAVITY

*The cavity ensures that the divergence of the beam is small*

- Only light traveling in a direction parallel to the cavity axis can undergo multiple reflections and make multiple passes through the amplifying medium.
- More divergent rays wander out of the cavity.

*The laser cavity also improves the spectral purity of the laser beam*

- The amplifying medium amplifies light within a narrow range of wavelengths.
- Within this narrow range, only cavity modes can undergo repeated reflection up and down the cavity
- Other modes are rapidly attenuated and will not be present in the output beam.

The result of the example indicates two important:

- For systems in thermal equilibrium, the rate of stimulated emission is very minor compared with the rate of spontaneous emission.  
*spontaneous emission is the most dominant mechanism*
- Radiation emitted from ordinary light sources in visible spectrum occurs in a random manner, i.e., *these sources are incoherent*.

**To produce coherent optical source and amplification of a light the rate of stimulated emission must be increased far above the stimulated emission**



**population  $N_2$  of upper energy level  $\gg$  population  $N_1$  of lower level**



### Population Inversion

population of the upper energy level is greater than population of the lower energy level (i.e.,  $N_2 > N_1$ ).

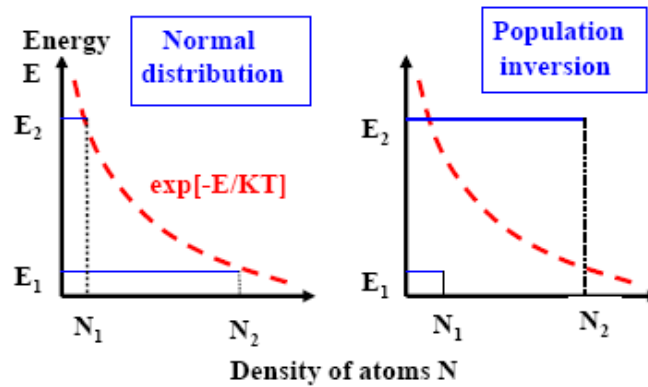

- It is achieved by using an external energy source "pumping".
- The two-level system is not convenient for suitable population inversion.
- In real application, it is achieved in:
  - three-level configuration: Ruby laser**
  - four-level configuration : He-Ne laser**

## Optical feedback and laser oscillation

- The laser structure (cavity) acts as a Fabry-Perot resonator.
- The amplification of the optical signal from a single pass in the amplifying medium is very small, i.e., a small number of photons are emitted by stimulated transitions.

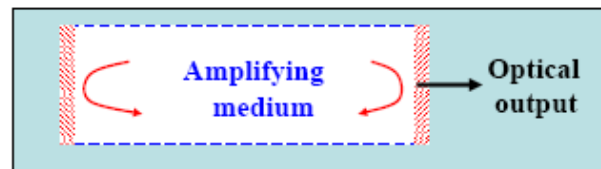

- The mirrors offer positive feedback for the photons.
- Then after multiple passes, avalanche multiplication of photons occurs in the cavity.

**the optical signal is greatly amplified, and gain becomes large**

## Optical feedback and laser oscillation,... continue

- During light propagation, photons are lost.
- A stable output is obtained when the optical gain is exactly matched by the losses, and then laser beam emits from the partial-reflection mirror

### The major losses

- absorption and scattering in the amplifying medium
- absorption, scattering and diffraction at the mirrors
- nonuseful transmission through the mirrors.

- The laser cavity helps to amplify modes over a small range of frequencies, i.e., the gain is large for several modes to overcome the losses



the device is not perfectly monochromatic  
**It emits over a narrow spectral bands**

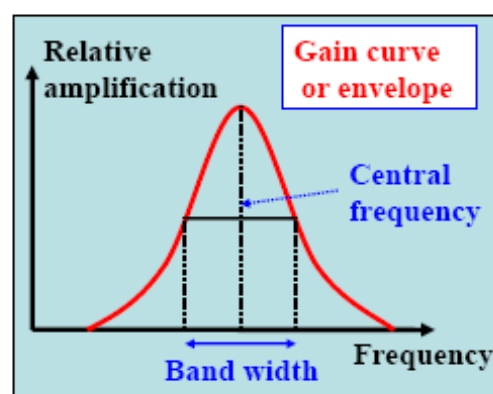



## نظام المستويين 2-Level System

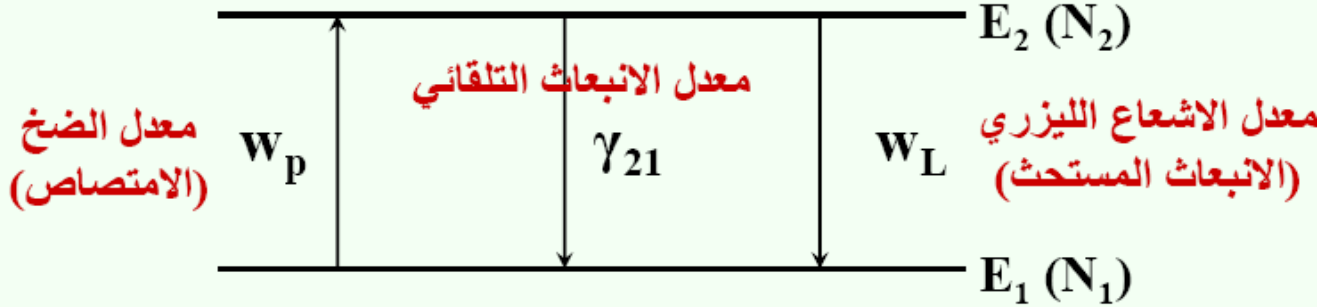

في أي لحظة زمنية ، يكون معدل تغير الإسكان الذري لمستويات الطاقة كالتالي :

$$\frac{dN_1}{dt} = \underbrace{-w_p(N_1 - N_2)}_{\text{الضخ}} + \underbrace{\gamma_{21}N_2}_{\text{الانبعاث التلقائي}} + \underbrace{w_L(N_2 - N_1)}_{\text{الانبعاث المستحث}} \quad (39)$$

$$\frac{dN_2}{dt} = -\frac{dN_1}{dt} = w_p(N_1 - N_2) - \gamma_{21}N_2 - w_L(N_2 - N_1) \quad (40)$$

حيث  $N_1 + N_2$  يساوي العدد الكلي لذرات النظام ، وفي حالة ثبات النظام فإن :

$$\frac{dN_1}{dt} = \frac{dN_2}{dt} = 0$$

ومنها نجد أن المعادلة (40) تؤول إلى :

$$w_p(N_1 - N_2) - \gamma_{21}N_2 - w_L(N_2 - N_1) = 0$$

$$\Rightarrow (w_p + w_L)N_1 - (\gamma_{21} + w_p + w_L)N_2 = 0$$

فإذا كان معدل الانبعاث التلقائي ضئيل جداً ( $\gamma_{21} \rightarrow 0$ ) فإن المعادلة الأخيرة سوف تؤدي إلى :

$$N_{2 \text{ max}} = N_1$$

أي أنه **من المستحيل** تحقيق الانعكاس السكاني بواسطة الضخ المباشر في **النظام ثنائي المستوى** ولا بد من استخدام نظام ذري ذي ثلاث مستويات أو أكثر

## نظام الثلاث مستويات 3-Level System

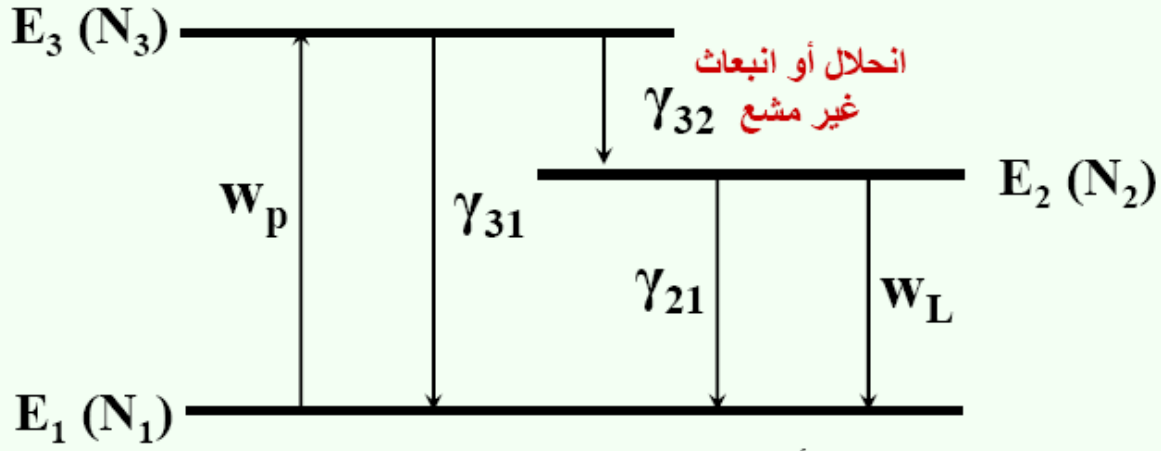

$W_p$  معدل الضخ أو الامتصاص

$W_L$  معدل الاشعاع الليزري أو الانبعاث المستحث

$\gamma_{31}$  معدل الانبعاث التلقائي من المستوى الثالث إلى المستوى الأول

$\gamma_{32}$  معدل الانبعاث التلقائي من المستوى الثالث إلى المستوى الثاني

$\gamma_{21}$  معدل الانبعاث التلقائي من المستوى الثاني إلى المستوى الأول

ويكون معدل تغير الإسكان في المستويات الثلاثة كالتالي :

$$\frac{dN_1}{dt} = -w_p(N_1 - N_3) + \gamma_{21}N_2 + \gamma_{31}N_3 + w_L(N_2 - N_1) \quad (41)$$

$$\frac{dN_2}{dt} = \gamma_{32}N_3 - \gamma_{21}N_2 - w_L(N_2 - N_1) \quad (42)$$

$$\frac{dN_3}{dt} = w_p(N_1 - N_3) - \gamma_{32}N_3 - \gamma_{31}N_3 \quad (43)$$

وفي حالة ثبات النظام فإن المعادلات السابقة تؤول إلى الصفر (المشتقة بالنسبة للزمن = صفر)

$$-w_p(N_1 - N_3) + \gamma_{21}N_2 + \gamma_{31}N_3 + w_L(N_2 - N_1) = 0 \quad (44)$$

$$\gamma_{32}N_3 - \gamma_{21}N_2 - w_L(N_2 - N_1) = 0 \quad (45)$$

$$w_p(N_1 - N_3) - \gamma_{32}N_3 - \gamma_{31}N_3 = 0 \quad (46)$$

## Threshold Condition شرط العتبة

$$N_1 = N_2 - \Delta N \iff \Delta N = N_2 - N_1 \text{ الانعكاس السكاني}$$

وحيث الاسكان الكلي يساوي مجموع الذرات في كل مستوى فإن  $N = N_1 + N_2 + N_3$

وفي ليزر المستويات الثلاث وبسبب الانبعاث غير المشع عالي المعدل فإن إسكان المستوى 3 يؤول إلى الصفر وتصبح المعادلة الأخيرة كالتالي :

$$N = N_1 + N_2$$

وبالتعويض عن قيمة  $N_1$  نحصل على :

$$N_2 = \frac{N}{2} + \frac{\Delta N}{2} \quad (54)$$

أي أن أكثر من نصف ذرات الوسط الفعال في المنظومة الليزرية يجب أن تكون في حالة إثارة

أ، ف، المسته 2،

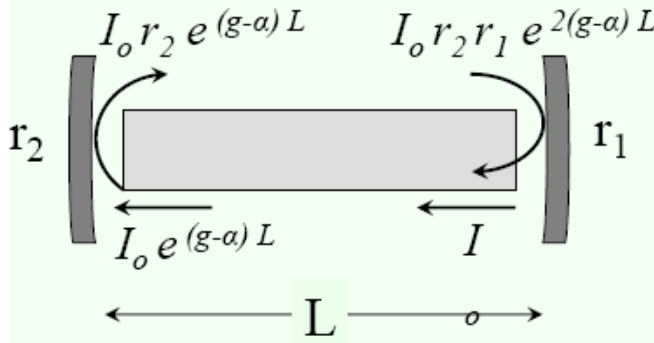

طول فجوة الليزر	$L$
انعكاسية سطحي الفجوة	$r$
معامل الكسب	$g$
الفقد داخل الفجوة	$\alpha$
الشدة الابتدائية	$I_0$

الكسب الكلي في المنظومة الليزرية  
خلال دورة كاملة

$$G = \frac{\text{الشدة النهائية خلال دورة كاملة}}{\text{الشدة الابتدائية}}$$

$$G = \frac{I_0 r_2 r_1 e^{2(g-\alpha)L}}{I_0}$$

$$G = r_2 r_1 e^{2(g-\alpha)L} \quad (62)$$

وباعتبار شرط العتبة للحصول على الليزر هو  $G = 1$

$$g(f) = \frac{1}{2L} \ln \left( \frac{1}{r_1 r_2} \right) + \alpha \quad (63)$$

## تأثيرات الليزر laser effects

### تصنيفات الليزر من حيث المخاطر

يصنف الليزر بأربعة تصنيفات تعتمد على خطورتها على الخيايا الحية. فعند التعامل مع الليزر يجب الإنتباه إلى الإشارة التي توضح تصنيفه.



إشارة تحذير بوجود ليزر

تصنف أنواع الليزر طبقاً لقوانين السامة في المقاييس الدولية بناء على درجة ضررها على جسم الإنسان ولا بد من التذكير بأن أكثر الأضرار الناتجة عن استخدام الليزر ليست بسبب أشعته وإنما بسبب سوء استعمال مصادر الطاقة اللازمة لبعض أجهزة الليزر خاصة الكبيرة من ذلك أجهزة توليد الطاقة عالية الجهد أو المواد الكيميائية المؤذية للإنسان. أما الضرر الناتج عن أشعتها فيكون غالباً على عين مستخدمه وهذا لا يعني عدم خطورتها على الأعضاء الأخرى. تعتمد الأضرار التي قد يتسبب بها الليزر للعين البشرية على التالي:

1 - مدة التعرض للأشعة.

2 - شدة الأشعة .

3 - لون الليزر (أو ما يعرف بالطول الموجي).

خطورة الليزر على العين:

إن أقصى شدة إضاءة تتحملها عين الإنسان دون أن تصاب بأضرار تبلغ حوالي 5 ميكروجول على السنتمتر المربع. ولما كانت الطاقة التي تتعرض لها عين الإنسان تقل كلما ابتعد عن مصدر أشعة الليزر، فإن مسافة الأمان هي أقل مسافة بين العين وجهاز الليزر، بحيث إذا تعرضت العين لنبضة ليزر مباشرة فاصاب بضرر. وتختلف هذه المسافة حسب العوامل الآتية:

أ - حالة الجو .

ب - أجهزة التكبير الضوئية المستخدمة في أجهزة الرؤية .

ج - الانعكاسات الضارة .

د - درجة تركيز شعاع الليزر .

هـ - نوع مادة الليزر .

و - نوع شعاع الليزر، نبضي أو مستمر.

• التصنيف الأول Class I هذا يعني أن شعاع الليزر ذو طاقة منخفضة ولا يشكل درجة من الخطورة

وهي.

- آمنة بحيث لا تتجاوز طاقتها الحد الأقصى من مستوى الإشعاع المسموح به على العين.
- التصنيف الأول Class IA هذا التصنيف يشير إلى أن الليزر يضر العين إذا نظرنا في اتجاه الشعاع ويستخدم في السوبرماركت كماشح ضوئي وتبلغ طاقة الليزر الذي يندرج تحت هذا التصنيف 4mW.
- التصنيف الثاني Class II هذا يشير إلى ليزر ضوئه مرئي وطاقته منخفضة لا تتعدى 1mW وهي آمنة ومصدر الأمان هنا حساسية العين بالإغماض اللاإرادي عند تعرضها لهذه الأشعة مباشرة أي بعد ربع ثانية.
- التصنيف الثالث Class IIIA طاقة الليزر متوسطة وتبلغ 1 - 5mW وخطورته على العين إذا دخل الشعاع المباشر في العين. ومعظم الأقسام المؤشرة وليزرات ألعاب الأطفال تقع في هذا التصنيف.
- التصنيف الثالث Class IIIB طاقة هذا الليزر أكثر من المتوسط.
- التصنيف الرابع Class IV وهي انواع الليزر مرئية وغير مرئية (سواء تحت حمراء أو فوق بنفسجية) ذات الطاقة العالية وتصل إلى 500mW للشعاع المتصل بينما لليزر النبضات فتقدر طاقتها بـ  $10^2 \text{J/cm}$  ويشكل خطورة على العين وعلى الجلد واستخدام هذا الليزر يتطلب العديد من التجهيزات وإجراءات الوقاية.
- التصنيف الخامس Class V وهي ليزرات القدرة العالية وتبعث أشعة مرئية وغير مرئية وهنا يجب الحذر من انعكاس الأشعة ولو من أجسام خشنة أو معتمة وهذا النوع قد يؤدي إلى حدوث حريق في الممتلكات .

## تأثيرات الليزر

### التأثير الحراري The thermal effect

يعتبر التأثير الحراري من أهم التأثيرات بالنسبة لليزر. ينتج هذا التأثير عن امتصاص النسيج للطاقة التي يحتوي عليها شعاع الليزر، وتبعاً لذلك ينشأ ثلاث درجات من التأثير هي: التخثر، القطع، والتبخير. يستخدم تأثير التخثر إما في إتلاف (تخريب) الظواهر الورمية الصغيرة، وإما في الإرقاء (وقف النزف). يستخدم تأثير التبخير في إتلاف (تخريب) أورام أكبر ما هو عليه في حالة تأثير التخثر. فإذا كانت المنطقة المتبخرة صغيرة جداً (1-0.1mm) نحصل على ما يسمى فعل القطع مع إرقاء ممتاز للحواف. يمكننا اليوم إحصاء عدد كبير من تطبيقات الليزر الحرارية الطبية نذكر منها ما يلي:

- ✗ لحم الشبكية: يسهم تأثير التخثر الضوئي باستخدام ليزر الأرجون في: الوقاية من انفصال الشبكية، ومعالجة بعض أمراض الشبكية السكرية.
- ✗ في معالجة الحنجرة وآفات الحبال الصوتية الحميدة بشكل خاص، وفي جراحة الأذن الداخلية وفي الأنف. كما تستخدم في معالجة الأمراض النسائية وذلك بإتلاف آفات عنق الرحم الإلتهابية التي تؤدي إلى ظهور سرطان لاحق، وكذلك في علاج نوع خاص من العقم (العقم البوقي).
- ✗ في معالجة بعض آفات الأنبوب الهضمي النزفية وذلك باستخدام مخثرات فوتوليزيرية، كما يمكن إتلاف بعض السليبات في المستقيم أو القولون ووقايتها من السرطان. كما يستعمل في حالات استئصال بعض مراحل سرطان المعدة والأورام المبكرة في القولون ويستعمل أيضاً كخط عاجي لإزالة الانسداد نتيجة للأورام المتقدمة في المريء والقولون وذلك عن طريق استعمال مناظير الجهاز الخطي، كما يستعمل في استئصال قرح الجلد والبروستات وبعض أورام الأوعية الدموية

☒ نه لا يصلح في ذلك الجراحة التقليدية, بالإضافة إلى توسيع الشرايين في حال انسدادها. في الجراحة التجميلية وجراحة الحروق والوشم وطب الأسنان. في مجال طب الأسنان لقد أجريت أبحاث وتجارب عديدة للوقاية من نخور الأسنان، وكان هدف هذه المعالجة زيادة مقاومة ميناء الأسنان في مناطق شديدة الخطورة وذلك عن طريق تغطية السن بطبقة شفافة رقيقة باستخدام نبضة ليزرية قصيرة مما يؤدي إلى تصلب الجزء السطحي من الميناء دون ظهور صدوع، يمكن أن تشكل مركزاً إثنانياً يتسبب في النخر. تعالج النخور حالياً بالليزر الذي يعقم البؤرة الالتهابية مما يوقف النخر فوراً ويعالجه في مدة قصيرة.

### التأثير الكهركيميائي The electrochemical effect

يستخدم التأثير الكهركيميائي في تخريب بعض الأحماض الأمينية (تيروزين، تريبتوفان، وفينيلالانين) وكذلك السيتوكروم C. كما يُفيد في تشكّل الفيتامين D وآلية الإبصار. كما يمكن بواسطة القيام بتشخيص طبوغرافي دقيق، وذلك عن طريق وسم الخلايا بملون يتفلور لدى إضاءته بشكل دائم. وإذا أمكن بالإضافة لذلك تحريض تفاعلات كهركيميائية في الملون نحصل بنتيجة ذلك على تأثير عاجي في الوقت نفسه، كما هو الحال في معالجة الصُداف وبعض الأورام السرطانية. ومن الممكن أيضاً استخدام هذا التأثير في معالجة بعض الحصيات الكلوية.

### التأثير الكهروميكانيكي The electro-mechanical effect:

يتميز بهذا التأثير الليزر ذو الاستطاعة العالية، وذلك بتوليد موجات صدم تتسبب بانتشارها في تأثيرات متلفة (مخرّبة)، فإذا أمكن السيطرة على مثل هذا النوع من الليزرات يصبح مفيداً في طب العيون وذلك في معالجة بعض الآفات.

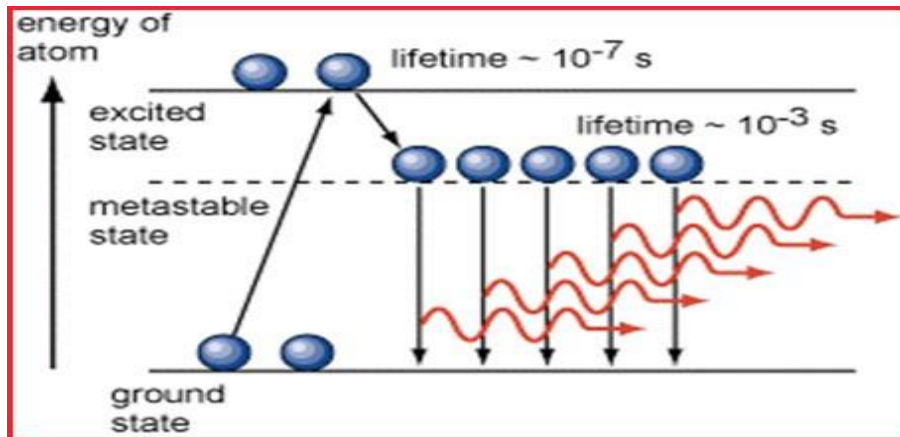
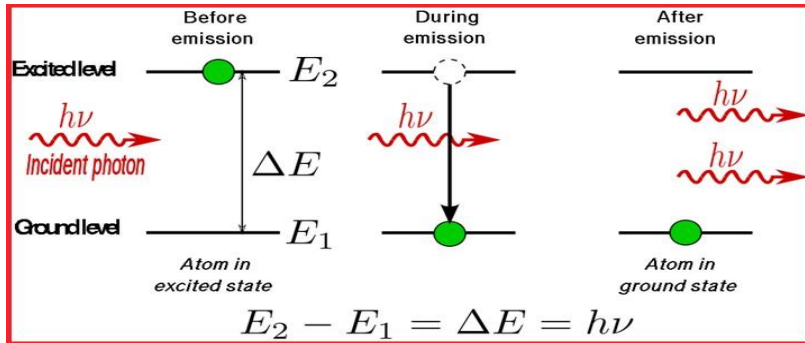



**laser classification:**

A - Continuity of radiation: continuous or pulsed.

The pulsed laser emits its beam in the form of a series of very short light pulses. These pulses are issued only when the active medium is in its highest excited state. Some types of lasers emit their beams at a rate of one pulse every few minutes. There are types of lasers, such as the carbon dioxide laser, whose waves can be pulsed or continuous.

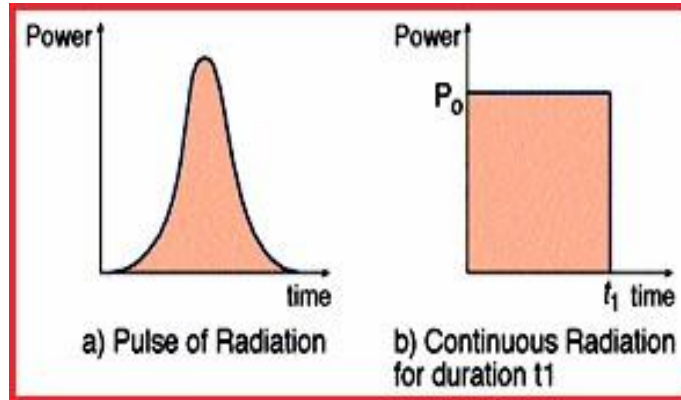

b - Radiation frequency: visible light, ultraviolet rays, infrared rays, X-ray lasers. ت

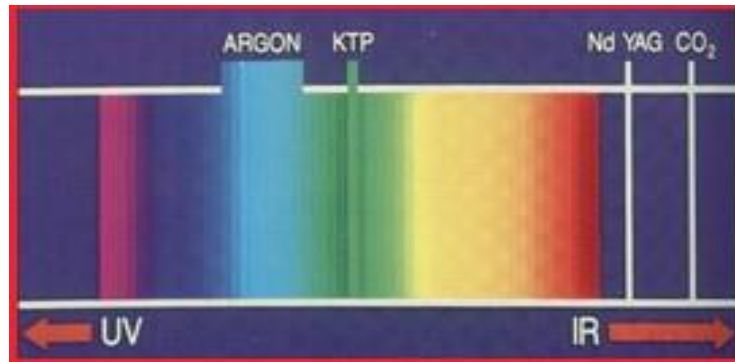

Any laser beam generator device consists of the following:

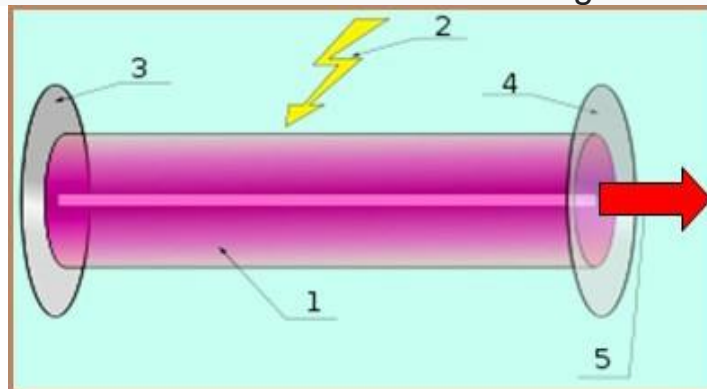

## Three Level Laser

A schematic energy level diagram of a laser with three energy levels is shown in figure .

The two energy levels between which lasing occur are: the **lower laser energy level ( $E_1$ )**, and the **upper laser energy level ( $E_2$ )**.

To simplify the explanation, we neglect spontaneous emission.

To achieve lasing, energy must be pumped into the system to create population inversion. So that more atoms will be in energy level  $E_2$  than in the ground level ( $E_1$ ).

Atoms are pumped from the ground state ( $E_1$ ) to energy level  $E_3$ . They stay there for an average time of  $10^{-8}$  [sec], and decay (usually with a non-radiative transition) to the meta-stable energy level  $E_2$ .

Since the lifetime of the meta-stable energy level ( $E_2$ ) is relatively long (of the order of  $10^{-3}$  [sec], many atoms remain in this level.

If the pumping is strong enough, then after pumping more than 50% of the atoms will be in energy level  $E_2$ , a population inversion exists, and lasing can occur.

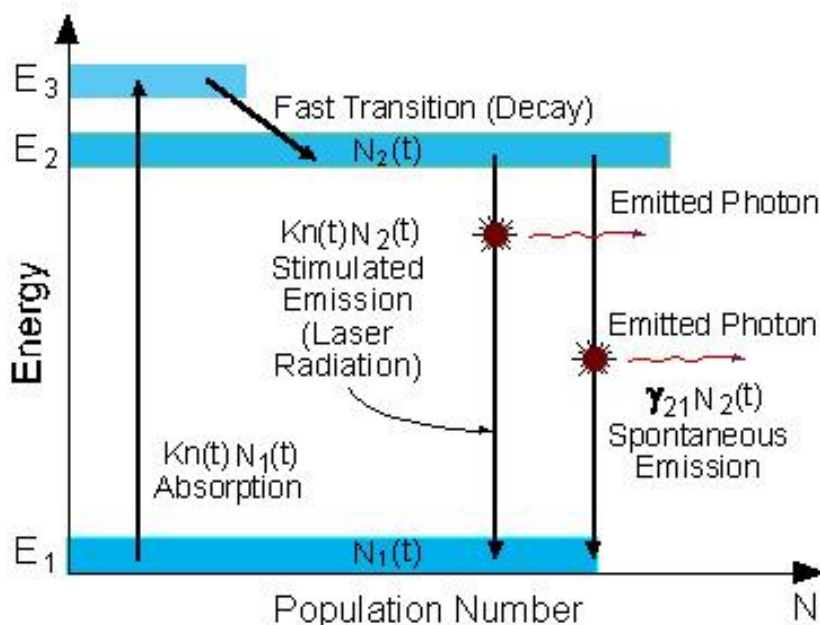

Figure: Energy level diagram in a three level laser

## Four Level Laser

-

The schematic energy level diagram of a four level laser is shown in figure . Compared to the equivalent diagram of a three level laser, there is an **extra energy level** above the ground state. This extra energy level has a **very short lifetime**.

The pumping operation of a four level laser is similar to the pumping of a three level laser. This is done by a rapid population of the upper laser level ( $E_3$ ), through the higher energy level ( $E_4$ ).

The **advantage of the four level laser** is the low population of the lower laser energy level ( $E_2$ ).

To create population inversion, there is no need to pump more than 50% of the atoms to the upper laser level.

The population of the lower laser level ( $N_2(t)$ ) is decaying rapidly to the ground state, so practically it is empty. Thus, a continuous operation of the four level laser is possible even if 99% of the atoms remain in the ground state ( )

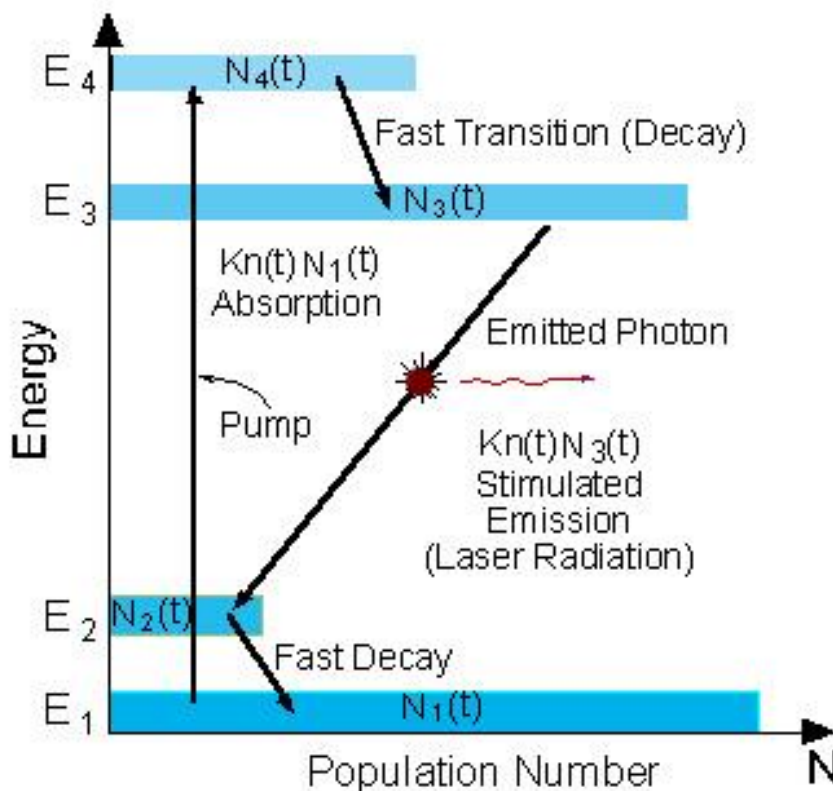
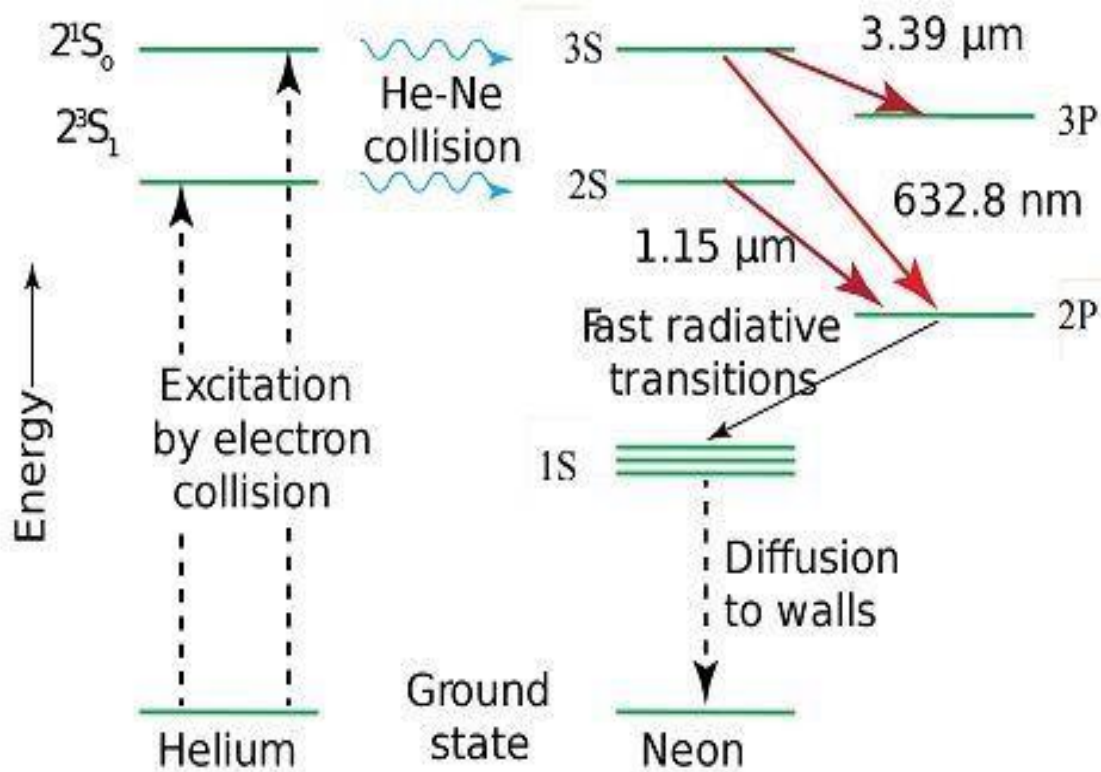
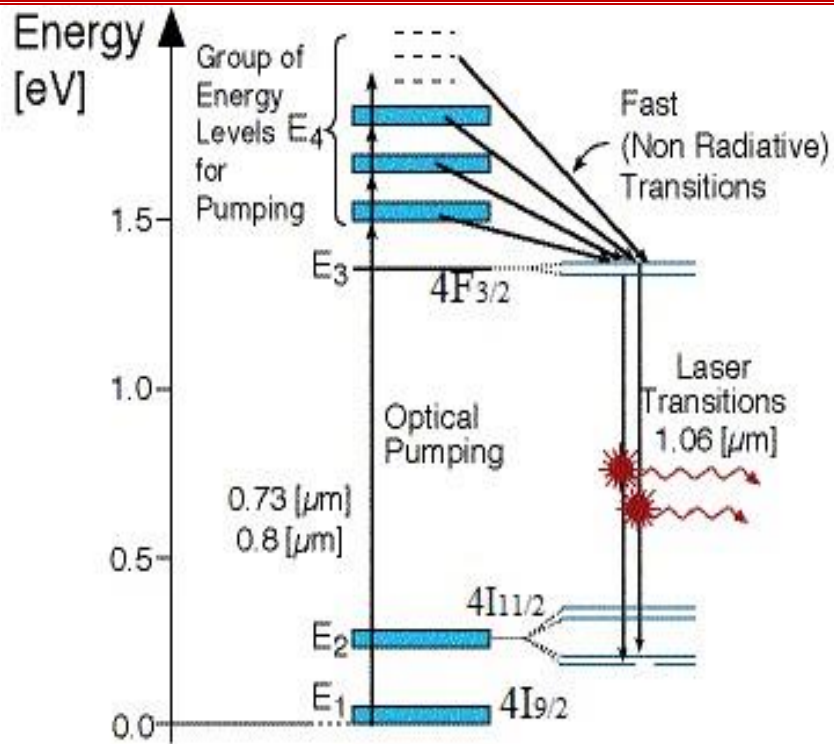
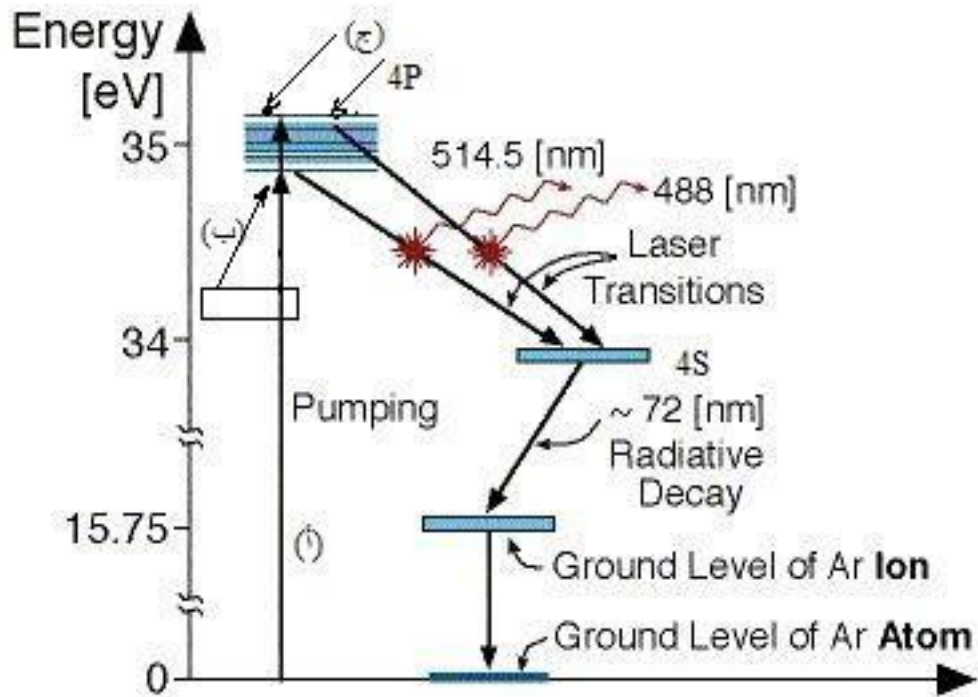

Figure: Energy level diagram in a four level laser





نوع الليزر	الطول الموجي لليزر (nm)
Argon fluoride (UV)	193
Krypton fluoride (UV)	248
Xenon chloride (UV)	308
Nitrogen (UV)	337
Argon (blue)	488
Argon (green)	514
Helium neon (green)	543
Helium neon (red)	633
Rhodamine 6G dye (tunable)	570-650
Ruby (CrAlO <sub>3</sub> ) (red)	694
Nd:Yag (NIR)	1064
Carbon dioxide (FIR)	10600

### Laser classifications risk



إشارة تحذير بوجود ليزر

Are classified as types of lasers in accordance with the laws of toxic in international standards based on the degree of harm to the human body and must be recalled that the more the resulting damage from the use of the laser is not because of the rays, but because of the misuse of sources of energy crisis for some special devices laser large that generating devices power high-voltage or materials harmful chemicals to humans. As for the damage resulting from its rays, it is mostly on the user's eye, and this does not mean that it is not dangerous to other organs. The damage that the laser may cause to the human eye depends on the following:

- 1 - The duration of exposure to radiation.
- 2 - Intensity of radiation.
- 3 - The color of the laser (or what is known as the wavelength).

### Fiber Optics

Whenever people talk about telephone or television systems that operate with terrestrial cables or Internet networks, the conversation is always associated with mentioning fiber optics, so what are optical fibers.

Optical fibers are long filaments of high-purity glass that are as thin as a human hair. These hairs are lined up together in a bundle called an optical cable. If you

look



closely at one of these optical fibers, you will find that it consists of:

The Core molding is an ultra-clear glass core that represents the path through which light travels.

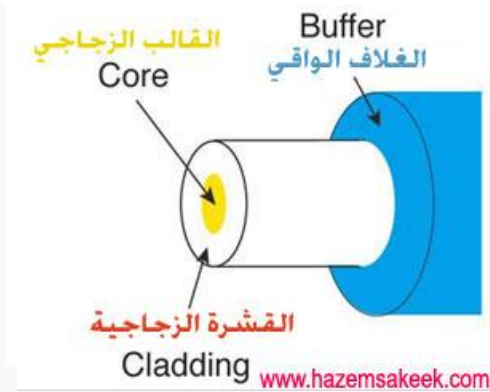

The glass shell is cladding, which is the outer material that surrounds the glass heart, and it is made of glass whose refractive index differs from the refractive index of the glass from which the heart is made and constantly reflects light to remain inside the glass mold Buffer coating is a plastic covering that protects the heart from damage Hundreds or perhaps thousands of these optical fibers are lined up together in a bundle to form an optical cord that is protected by an outer covering called

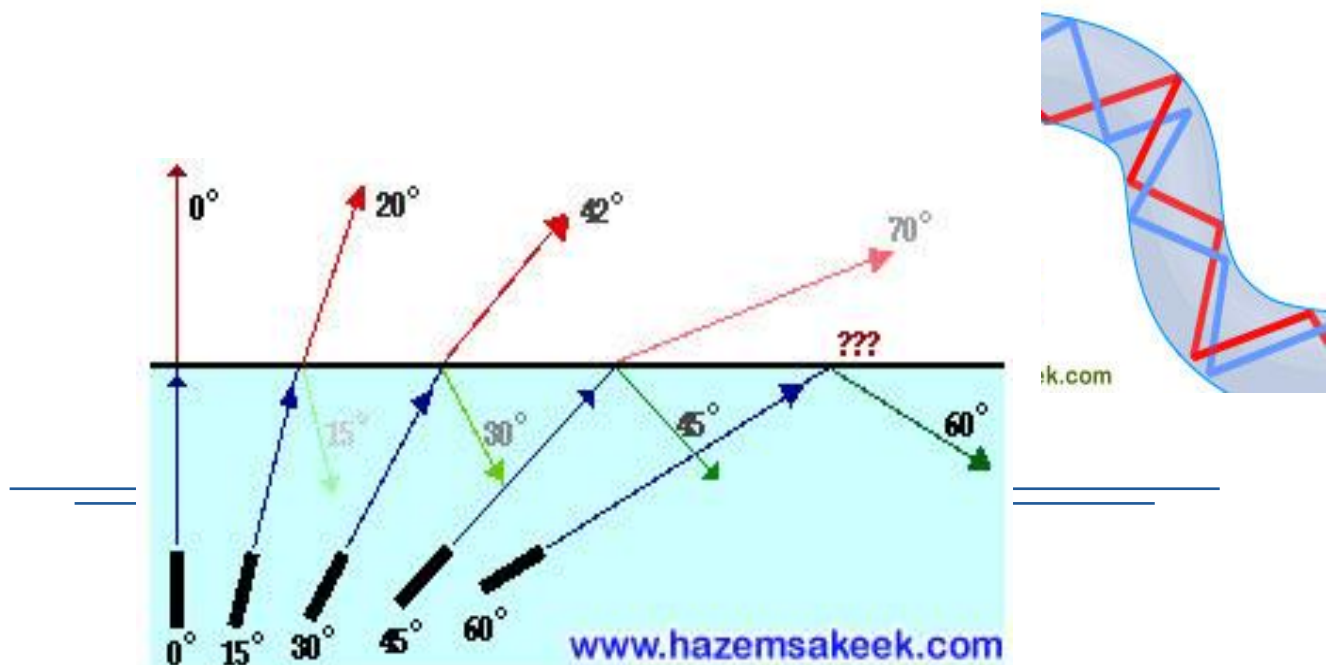

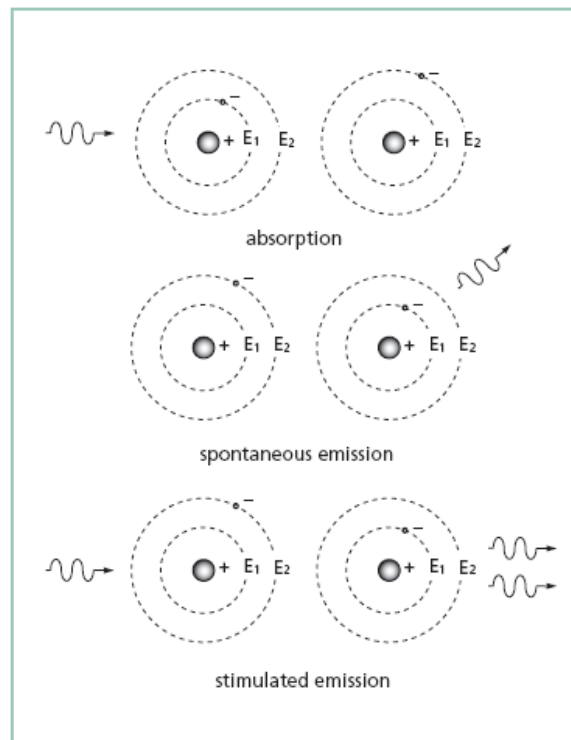

Figure 36.2 Spontaneous and stimulated emission

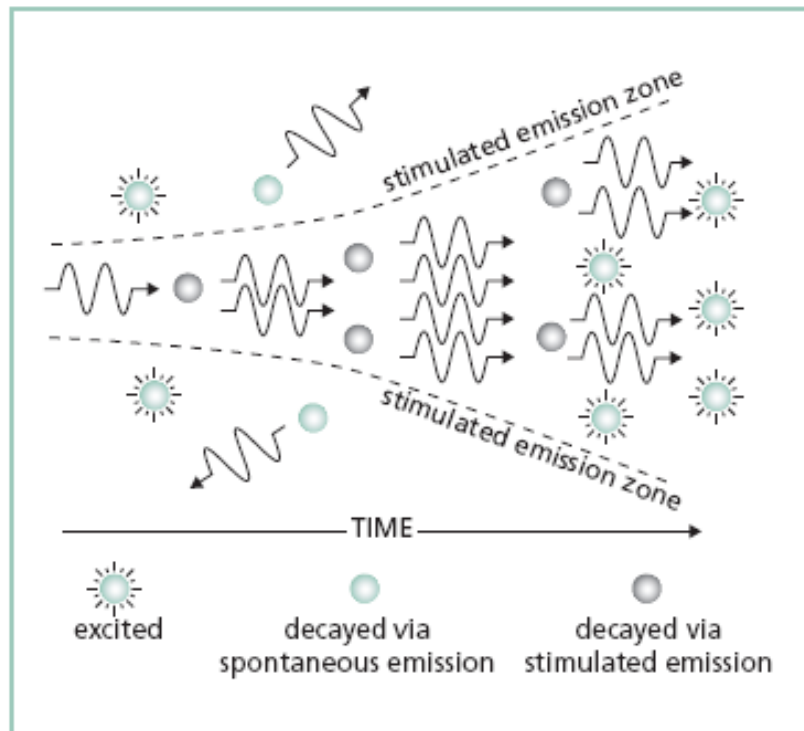
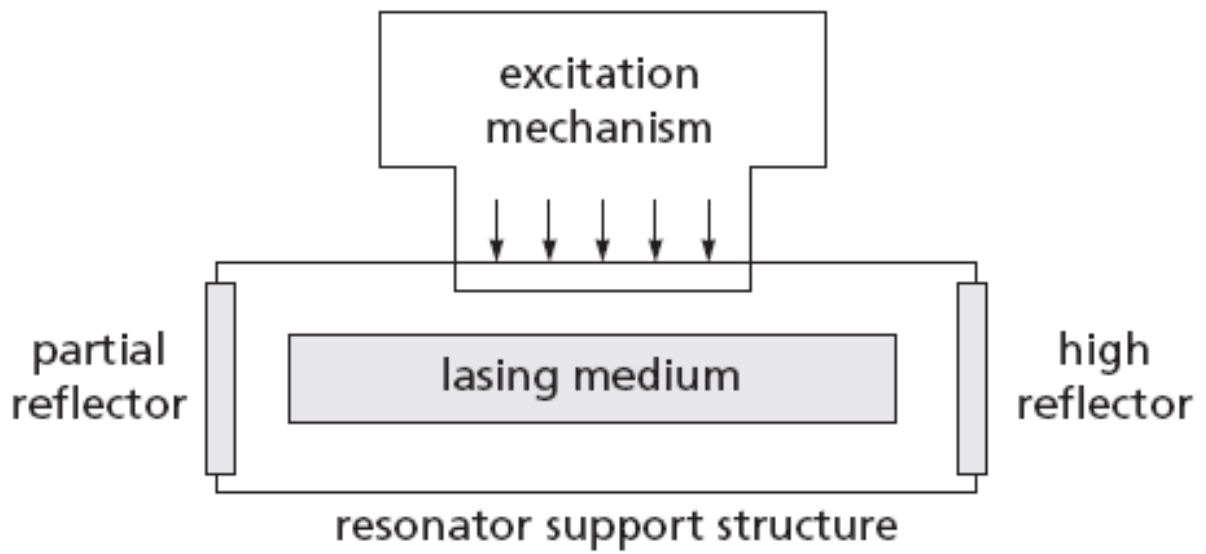

Figure 36.3 Amplification by stimulated emission



## Chapter 3

### Laser Applications

#### تطبيقات الليزر الطبية

تستخدم أشعة الليزر بمختلف أنواعها في الجراحة وفي مجال طب الأسنان وطب العيون والأمراض الجلدية

ففي مجال طب وجراحة العيون يستخدم الليزر في علاج العتمة السطحية للقرنية وفي علاج العيوب الإنكسارية للعين كقصر النظر وطول النظر والإستجماتيزم وذلك عن طريق العديد من التقنيات أهمها تقنية الليزك (LASIK) وتقنية الازك (LASEK) وغالباً ما يستخدم ليزر الإكسايمر (Excimer) في هذا النوع من العلاج بسبب قصر طول موجته وصغر قطر شعاعه. وتستخدم كذلك في علاج المياه البيضاء والزرقاء في العين من خلال إجراء ثقب صغيرة جداً في قرنية العين يعمل على تصريف هذه المياه والتخفيف من ضغط العين. ويستخدم الليزر في علاج أمراض الشبكية الناتجة عن مرض السكري أو غيره من الأمراض كوقف نزيف الشبكية من خلال كي نهايات الأوعية الدموية وكذلك وقف انفصال الشبكية عن الملتحمة من خلال كيها باستخدام ليزر الأرغون.



وفي الجراحة يتم استخدام شعاع الليزر كمشروط في العمليات الجراحية حيث يتميز بدقته العالية إلى جانب عدم حدوث أي نزيف في مكان الجرح بسبب قيامه بلحام النهايات الطرفية للشعيرات الدموية ويستخدم كذلك بإزالة الأورام بمختلف أنواعها من خلال تبخيرها بدلاً من استئصالها بالمشروط مما يقلل من الضرر على الأنسجة السليمة المحيطة بها وخاصة في الأعضاء الحساسة كالدماع والكبد والعيون. ومن أنواع الليزر المستخدمة في هذا المجال ليزر ثاني أكسيد الكربون والأرغون. وفي طب الأسنان يستخدم الليزر لحفر الأسنان بشكل بالغ الدقة وكذلك لتنظيف أسطحها. وفي الأمراض الجلدية يستخدم الليزر لإزالة البثور وحب الشباب والتجاعيد والوحمات والنمش وأثار الحروق والوشم والشعر الزائد وفي معالجة بعض الأمراض الجلدية كالبهاق والصدفية. ويستخدم الليزر في تفتيت حصى الكلى والمرارة وإزالة الأورام في داخل أعضاء جسم الإنسان وذلك من خلال نقل شعاعه بواسطة ألياف زجاجية دقيقة يمكن إدخالها بكل سهولة في التجويفات والمسالك والأوعية أو من خلال ثقب صغيرة يتم فتحها في جلد الجسم.

#### تطبيقات الليزر في طب الأسنان

غدا شعاع الليزر في السنوات الأخيرة حجر الأساس في عالم طب الأسنان وجراحاتها، حفر السن، إزالة العصب الملتهب، تنظيف وتهيئة قنوات العصب، كما يمكن تنظيف الأسنان واللثة وإعادة بياض الأسنان، وإزالة رائحة الفم الكريهة الناتجة عن أمراض اللثة. ويزيل البقع الناشئة عن التسوس. ويوقف انتشاره في أجزاء

السن السليمة. إذ يقوم بتعقيمها من الجراثيم والبكتيريا ويساعده في ذلك اللون القاتم لموضع التسوس. فالجزء القاتم من السن أشد امتصاصاً لطاقة الليزر من باقي أجزاء السن السليمة البيضاء. والتي تمتاز بانعكاسية شديدة له.

إزالة الأورام الحميدة وبدون الحاجة في كثير في الحالات للمخدر الموضعي أو خياطة الجرح. إطالة التاج Crown Lengthening: وذلك بإزالة أجزاء بسيطة من اللثة ليتمكن طبيب الأسنان من إعداد التركيبة المناسبة للأسنان.

إزالة بعض الأورام الصلبة أو الطرية Epulis Soft Tissue الموجودة على الفكين أو أحدهما للمساعدة في استخدام أطقم للأسنان، وكذلك إزالة الأنسجة المتورمة بسبب بعض الأدوية. تخفيف الألم والالتهابات التي تصيب المفصل الصدغي.



ابتسامة اللثة gummy Smile: يستخدم الليزر أيضاً لإعادة تشكيل أنسجة اللثة وعرض أجزاء أكبر من الأسنان السليمة وتحسين الشكل لابتسامة عند الأفراد الذين يتصفون بظهور اللثة عند تبسمهم. إزالة الأنسجة المغشية جزئياً للأرحاء الثالثة البازغة جزئياً.

علاج الخراجات باللثة وعاج قنوات جذور الأسنان الملتهبة، وتقليل أعداد البكتيريا الموجودة في جيب اللثة. علاج مشاكل النطق التي بسبب (Tongue tie) والتي تمنع الحركة الطبيعية للسان.

زيادة مقاومة أنسجة السن، سواء طبقة المينا أو طبقة العاج، لاحتمال حدوث التسوس، وذلك نتيجة تأثير اشعة الليزر والطاقة الاشعاعية المصاحبة لها في صهر والتحام بعض أجزاء جسم السن. وفي الوقت نفسه فإن حماية أنسجة السن عن طريق اضافة الفلور، تعتبر من اكثر الوسائل استخداما كوقاية ضد التسوس، لذلك اعتبر دمج الطريقتين باستخدام اشعة الليزر ملحقة بإضافة محلول الفلوريد، قد يكون وسيلة جديدة ومؤثرة لحماية طبقات الاسنان من التسوس. وهذا حقق الى حد ما أهم اهداف العاج المحافظ لاسنان، وهو الحفاظ على جسم السن من خال العاج والوقاية من حدوث التسوس.

#### فوائد استخدامات الليزر في الطب

يمكن باختصار عرض تلك الفوائد كما يلي:

- لا يوجد أي اتصال بين الأدوات المستخدمة والهدف (مكان الجراحة).
- قلة النزف الذي يصحب عمليات جراحة اللثة.
- رفع عتبة الألم (تقليل الألم) أثناء العمل الجراحي وبعده.
- عدم الحاجة إلى التعقيم (تعقيم مثالي).

- تقليل الحاجة لاستخدام سنابل الحفر والتحذير الموضعي مما يجعل المريض يحس براحة أكثر ويقفل من الخوف من عيادات الأسنان.
  - في كثير من الأحيان يعتبر عاجاً وتدخلاً أكثر دقة More Precise.
  - تقليل العدوى البكتيرية حيث High Energy Beam يعقم المنطقة.
  - تدمير الأنسجة المحيطة يقل.
  - وضوح الرؤية عند أداء العملية.
  - سهولة العمل تحت المجهر.
  - إمكانية إحداث شق موضعي محدد (دقة القطع).
  - إرقاء ممتاز للأوعية الصغيرة.
  - إمكانية معالجة أنسجة دون أخرى (باختيار طول موجي معين).
  - اجراء عمليات من غير فتح جراحي (باستخدام الألياف البصريّة) وذلك لمعالجة أورام المثانة والرئة والكلية.
  - في جراحات الأمراض الخبيثة مثل السرطان والقروح وجراحات الأوعية الدموية، ويستعمل أيضاً في توسيع الشرايين وعاج قصور الدورة الدموية في الأطراف وفي عاجات الحبل الشوكي وجراحات أخرى كالمعدة والكبد.
  - اندمال جيد للجروح.
  - فترة المعالجة قصيرة ويغادر بعدها المريض المشفى.
  - علاج الآفات الذروية، معالجة حساسية الأعناق، القاع، والتواج.
  - الدقة في العاج وذلك من خال التحكم في العملية عن طريق الحاسب الآلي.
  - يقلل من الحاجة للتخدير الموضعي.
  - يقلل من قلق المريض بسبب انخفاض صوت الجهاز مقارنة بجهاز حفر الأسنان الاعتيادي. لذا فان المريض يكون أقل توتراً.
  - اثناء عملية حفر الأسنان، يقوم الليزر بالمحافظة على الأجزاء السليمة من السن المراد حفره.
- مساوئ استخدام الليزر في طب الأسنان**
- لا يمكن استخدام الليزر على الأسنان التي بها حشوات قديمة.
  - لا يمكن استخدام الليزر على الأسنان المتسوسة كلياً.
  - لايمكن استخدام الليزر لتحضير الأسنان لاستام تاج أو جسر العاج بالليزر لا يغني كلياً عن التخدير.
  - تكلفة العلاج بالليزر غالباً ما تكون أعلى.

### تطبيقات الليزر في المجالات الأخرى

توجد حالياً أنواع وأحجام مختلفة من الليزرات ، منها الكبيرة لدرجة أنها تملأ ملعب كرة قدم ، وأخرى صغيرة قد تصل إلى حجم رأس الدبوس ، وكما أسلفنا فإن ضوءها يغطي مناطق كثيرة من المنطقة المرئية إلى فوق البنفسجية وتحت الحمراء ، والمرئية منها بألوان متعددة تشمل كل ألوان قوس قزح تقريباً .  
إن بعض هذه الليزرات يقدر نبضها بواحد من البليون من الثانية ، وأخرى تبقى مستمرة لسنوات تماثل أشعة الموت



تخليها الروائي ويلز عام 1898م ، وبعض الليزررات يمكن أن تركز الضوء في نقطة صغيرة كافية لتبخير الحديد أو أية مادة أرضية أخرى . وتعتبر الطاقة المركزة فيها أسرع وأشد مليون مرة من الانفجار النووي . والأخرى لا تبعث من الطاقة ما يكفي لسلق بيضة .

إن الخدمات التي أضافتها أشعة الليزر عبر الأيام والأشهر قد أوضحت بأن اكتشاف هذا الشعاع ليس بالأمر البسيط ، لأنه في الواقع يبشر بمستقبل باهر ، ممتع وغريب ، ونذكر منها ما يلي :-

- دراسة تأثير الفيروسات ( الجراثيم ) والإنزيمات وجزئيات الحموض النووية الريزوبية اللاكسيجية DNA ، والمبادئ الأساسية للمعلومات عن الجينات التي تحمل السمات والوراثية .
  - الطاقة غير المحدودة للمساعدة في عملية اندماج نظائر الهيدروجين في تقليد للوقود النووي في الشمس .
  - علاج الأورام السرطانية والقضاء عليها ، وإعادة فتح الشرايين والأوردة المغلقة في الجسم .
  - القدرة على تعقب جزئية واحدة من بين آلاف البلايين من الجزئيات والتقاط حركتها السريعة أو تدجينها لعمل المحفزات والعقاقير .
  - بناء الحسابات الآلية الصغيرة الحجم ، ذات كفاءة التخزين الكبيرة والسريعة من الدوائر الضوئية أو تدجينها لعمل المحفزات والعقاقير .
  - القدرة على رفع الكفاءات الحربية في الفضاء الكوني ، عرقلة وتوفيت أي هجوم نووي على الأرض .
- لا تستهين بالليزر . فإنه يسخر ويطيح الضوء ، الشكل الأساسي للطاقة . فقط طبعنا وسخرنا الطاقة في أشكالها الأخرى وحصلنا على الثورة الصناعية في العالم . إن معرفة خفايا وكوامن الضوء والسيطرة عليها تعطي تقنية عميقة وقادرة ، وتفتح علوماً طالما خفيت على الإنسان ، ومن التطبيقات الصناعية ندرج الأمثلة التالية :-

### 1- الصناعات الكهربائية :-

البقعة الفائقة الشدة في حرارتها والمتكونة من تركيز طاقة الليزر تستعمل في صناعة الدوائر والأجهزة الإلكترونية الدقيقة . وكمثال على ذلك من الممكن لحام ( إذابة وصهر ) نهايتي سلكين منفصلين صغيرين بعد وضعهما داخل أنبوب زجاجي مغلق وبدون الحادة إلى إخراجهما من الأنبوب الزجاج وبدون التأثير عليه ، بينما يمتص من قبل نهايتي السلكين ويصهرهما مع بعضهما . ربما نذكر القارئ الكريم بملايين المصابيح واللمبات الكهربائية والإلكترونية والتي يمكن إعادة تصنيعها بهذه الطريقة.

### 2- عصر الفضاء :-

إن تطور الليزر كان ولا يزال سريعاً ، لهذا الدخل في تطبيقات متنوعة وفي فترة زمنية وجيزة ، حيث إن الاستفادة من اتجاهيته وقدرته وضعه في موضع اهتمام في الاتصالات الفضائية لدراسة الكواكب والنجوم في هذا الكون الفسيح ، ولنا وقفة عاجلة هنا ، حيث ذكر اينشتاين في سنة 1905م في دراسته عن النسبية والكون الأحدب ، كيف أنه إذا أريد لنا اكتشاف المجرات الكونية والنجوم يلزمنا مركبة تنتقل بسرعة الضوء ووفقاً لنفس نظرياته المؤكدة عملياً اليوم بأن أي جسم يملك كتلة ويتحرك بسرعة الضوء تزداد كتلته إلى ما لا نهاية . . . هذا التناقض الواقعي وضع علماء الفضاء أمام عقدتين مستحيلتين في الوصول إلى الفضاء دراسته (أولهما) لا تيسر حالياً أية إمكانية في الوصول إلى سرعة تقدر بسرعة الضوء حتى لو استخدمت كل ما يوجد في الأرض من طاقة نووية اللهم إلا إذا أراد الله لنا أن نكتشف في الكواكب القريبة من مجموعتنا الشمسية مواد جديدة غير معروفة لنا . وكل ما اخترعه الإنسان حتى اليوم من صواريخ وعابرات قارات .... الخ ، لا تزيد سرعتها عن ثلث سرعة الضوء ، لذا اعتبرت سرعة الضوء مطلقة .

( ثانيهما ) . . . وحتى لو فرض بالحصول على جسم يتحرك بسرعة الضوء فإن كتلته حسب قوانين اينشتاين المثبتة عملياً تزداد إلى ما لا نهاية ( أثبتت عملياً باستخدام المعجلات في مسارعة الجسيمات الذرية مثل الإلكترونات والبرو

تونات ، ووجد أن كتلتها تزداد بزيادة سرعتها ، خصوصاً عند الأقتراب من سرعة الضوء ) هذه الحقيقة تعني أن الانفجار بالنسبة للمركبات الفضائية والأجسام المتألفة من سبائك مختلفة ، لذا يبدو من المستحيل الوصول إلى المجرات والكواكب الأخرى والذي من المعروف أن مسافاتها تقاس بالسنين الضوئية أي المسافة التي يتحركها الضوء في سنة كاملة .

### 3- التفاعلات النووية

تمثل التفاعلات النووية ، ( عدا استخداماتها الحربية في إنتاج القنابل النووية ) إحدى مصادر الطاقة المهمة في التزود بالطاقة الحرارية والطاقة الكهربائية ، وكما هو معروف يستخدم في هذه المفاعلات عناصر أصبحت نادرة وباهظة الثمن مثل اليورانيوم وفي طريقها ( مثلها مثل أي عنصر آخر ) إلى النضوب ، إلا أن مركبات اليورانيوم مثل فلوريد اليورانيوم موجودة ويتطلب لاستخدامها فصل اليورانيوم عن الفلوريد ، والطرق المعروفة حالياً باهظة الثمن والتكاليف .

والليزر بقدرته الهائلة والسيطرة على اختيار تردده أو طوله الموجي يعطي فتحاً جديداً في مجال العلوم النووية لفصل النظائر المشعة ، والأبحاث في أكثر من مختبر في العالم سارية بكل جدية في فصل الفلوريد عن اليورانيوم ، وكذلك في التفاعلات الاندماجية النووية الذرية Fusion ، وفي مجالات أخرى لفا تقل أهمية ، ولشدة قدرة الليزر يستخدم اليوم في البدء بالتفاعلات النووية المتسلسلة ، وبذلك تقصف النويات من عدة اتجاهات بعدد من أجهزة الليزر الفائقة القدرة ، ويتم اندماج ذرتان خفيفتان مع بعضهما لتكوين ذرة واحدة ثقيلة . ولكن كتلتها لا تساوي المجموع الجبري لكتلتي الذرتين المندمجتين - حيث يبقى باقي في الكتلة يتحول إلى طاقة ذرية أن تؤدي إلى انفجار كبير . . أو تحويلها إلى الأنواع الأخرى من الطاقة للاستعمالات السلمية مثل الطاقة الكهربائية أو الطاقة الحرارية .

### 4 - المدى والتلوث

استخدمت إلى حد قريب أجهزة الرادار Radar ، كوسيلة للكشف عن الأجسام القريبة وتعيين مواقعها ، وهذا الجهاز من الحرب العالمية الثانية وحتى اليوم وضع في تطبيقات سواء كانت عسكرية أو صناعية عديدة . واليوم ينظر إلى أشعة الليزر كبديل واسع وقوع ، والجهاز المستخدم يعرف باسم الايدر Lidar حيث يمكن بأجهزة الكايدولايت تصوير المعمورة من الجو وإعطاء أدق التفاصيل على خطوط بيانية .

أمكن قياس المسافة بين الأرض والقمر بدقة عالية باستخدام العاكس التراجعي الذي وضع على سطح القمر ، ووجد أن خطأ القياس كان قليلاً جداً بالمقارنة بالطرق التقليدية المتبعة سابقاً ، علماً بأن ضوء الليزر يأخذ زمناً قدره ثانيتين ونصف في ذهابه وإيابه من الأرض إلى القمر - وقد استخدم الليزر النبضي - ويعرف بصدى النبضات الليزرية .

كما استخدم الصدى النبضي لليزر في دراسة وقياس التلوث الجوي في المدن الصناعية التي تكثر بها المداخل المختلفة من بقايا المحروقات النفطية أو الفحم الحجري . وكذلك يمكن مساعدة الطيارين في الكشف عن الأحوال الجوية إذا كانت ملائمة وأمنة للإقلاع والهبوط في المطارات .

من الليزرات الشائعة الاستعمال لهذا الغرض هو ليزر خليط الهليوم والنيون وذلك لبساطته وتصنيعه وصغر حجمه خصوصاً للقدرات الصغيرة مثل 0.5 ملي واط .

### 5- التطبيقات الهندسية :-

في البحث عن المراكز الهندسية وفي التأكد بدقة من توازي وتعادم المستويات يعطي الليزر ، إما بالنظر المباشر أو بالقراءة الرقمية ، الدقة في التطابقات الهندسية حيث يحل وبكفاءة محل جهاز الفيديولايت الهندسي المعروف والمستخدم في حفر أنفاق السيارات والقاطرات تحت أو فوق سطح الأرض

### 6- نسخ المعلومات

يستطيع الليزر التعرف على الرموز المختلفة سواء كانت كتابات معينة أو رموز تجارية أو مصطلحات مخفية ، حيث إن شعاعه الدقيق يمكن أن يتحرك حول الرموز ، ويمكن كشف الحزم المنعكسة منها أو النافذة بأجهزة خاصة تعطي صورة دقيقة عن ماهية هذه المعلومات ، وإذا ربطت هذه الأجهزة بالكمبيوتر استطاع آلياً برمجة عمله لاعطاء الكشف الواضح أو نسخ ونقل المعلومات .

ومن الأعمال الأخرى في التسجيل بشعاع الليزر هي : نقل المعلومات من أجهزة المرصد الفلكية ، ونقل وصف خطوط المطابع الورقية ، والتسجيل التلفزيوني وقراءة الميكروفلم والكتابة منه على مواد مختلفة إما مباشرة أو باستخدام محولات كهروستاتيكية والعمل جاري لإيجاد مواد جديدة حساسة لضوء ليزر الهليوم - نيون . يعطي ضوء الليزر فوائد مهمة في عمليات التسجيل والنسخ منها

أ) السرعة العالية جداً والتي لا وجود لجهاز ميكانيكي أو الكتروني حالي يضاهيه ( التحليل النقي والذي لا يتحوي على ذبذبات تداخلية أو ضوضاء صوتية .

ج) السيطرة الكفوءة على استعماله عند ربطه بأجهزة الكمبيوتر وأجهزة التنظيم الصوتية والضوئية .

### 7- القياسات :

تستخدم صفة أو أكثر من صفات الليزر الرئيسية في القياس بهذه الأشعة مثل أحادية الطول الموجي ، والترابط الموجي ، والشدة العالية التركيز ، والتفريق القليل لحزمته .

والليزر حساس في القياس والتعرف على العيوب السطحية في المواد مثل الخدوش والكسور ، والخفر وقياس سماكة وأقطار الأجزاء المختلفة ، وخصوصاً في قطع الغيار التي كثيراً ما يحصل الخطأ في التشخيص العادي لها .

### 8- علم الطيف

ويستخدم ف علم الطيف في دراسة المواد المختلفة كماً ونوعاً ، وكان سابقاً يتم دراسة المواد باستخدام الموجات الكهرومغناطية في الترددات الراديوية إلى منطقة الميكروويف ، أي باستخدام ترددات تتراوح بين 30 كيلة هيرتز وما زاد عن ذلك تستخدم مصادر متعددة غير دقيقة .

### 9- الصناعات الإلكترونية الدقيقة :

يدخل الليزر في صناعة الإلكترونيات Resistors المختلفة من تقليم وتقصيص دقيق لابعادها ، إما يدوياً أو آلياً وبذلك يعطي حجم وقيمة كهربائية للمقاومة دقيقة جداً ، بالإضافة إلى الحفر في المواد المختلفة لتكوين المتسعات المتناهية الصغر ، وكذلك يدخل في لحم ووضع العديد من الدوائر الإلكترونية الدقيقة والصغيرة الحجم المستخدمة في الأجهزة الإلكترونية المختلفة .

### 10- السباكة :

الشدة الحرارية لليزر وخصوصاً بعد تركيزه ، وصغر مقطعه وسهولة السيطرة عليه يجعله مهماً في عالم السباكة ومعاملة المواد ، حيث أنه قادر على إذابة وتبخير المعادن ، من ثقبها إلى حفرها ، ومن قطعها إلى لحمها مع بعضها ، كلها يمكن أن تتم بهذه الأشعة بمجهود قليل وبدقة عالية ، كونه لا يحتاج إلى ضغط ميكانيكي في عمله .

وقد أثبت باستخدام الليزر النبضي بطاقة 20 جول في النبضة الواحدة ، إمكانية تبخير المادة بدلاً من إذابتها ، و 5 جول من النبضات المستمرة قادرة على الثقب واستعماله كمنقاب .

### 11- المواصفات والمقاييس :

في هذا المجال يدخل الليزر في أعمال كثيرة منها : آلة تصوير ( كاميرا ) سينمائية ذات سرعة عالية حوالي 10.000 صورة في الثانية لمراقبة التفاصيل الزمنية والمكانية للظواهر الحرجة مثل الانفجارات المختلفة ، ومراقبة أبخرة الاحتراق المتصاعدة من المحركات النفاثة . . الخ .

### 12- الاتصالات اللاسلكية :

أجهزة الاتصالات الكهرومغناطية العصرية معتمدة كلياً على الترددات الراديوية والموجات الدقيقة ( الميكروويف ) ، أما إهمال الموجات الضوئية في الاتصالات فهو لعدم توفر المصادر الضوئية بالإضافة إلى الصعاب الكثيرة الناتجة عن تفرق وتشتت الموجات الضوئية والامتصاص الجوي لها ... إلا أنه بتطور الليزر أوجد المصدر الضوئي المثالي للاتصالات اللاسلكية المستقبلية .

### 13- ذاكرة الحاسبات الآلية :

تستخدم حالياً طريقة التخزين المغناطيسي للمعلومات في ذاكرة العقول الإلكترونية Computers ، وذلك بالاستفادة من المجال المغناطيسي في التأثير على تركيب وتوزيع المواد في الشريط أو القرص الحافظ للمعلومات ، وفي العادة نحصل على شرائط طويلة في أقراص كبيرة .

سجل هذا العصر التطور في التخزين الضوئي للمعلومات باستخدام الليزر وقد أنتج قرص عرضه ( 5 سنتيمتر ) له سعة تخزين تصل إلى 10 مليون بايتز ( بلغة الكمبيوتر ) أي أن 5000 صفحة من كتاب يمكن أن تخزن في جهة واحدة من القرص . وهذه الذاكرة تخزن المعلومات بمعدل 250 كيلو بايتز في الثانية وتعطي المعلومات بنفس المعدل .

وتصل دقة بحث الذاكرة في 0.1 من المليون في المتر ، ودقة التركيز تقدر بواحد من المليون في المتر .

### 14- الزراعة :

عند تعريض بذور الحنطة لأشعة الليزر أحدثت تشوهات جنينية فيها والتي أدت بدورها إلى زيادة الإنتاج بمقدار 80% . بالإضافة إلى ذلك إمكانية التعقيم وقتل البكتيريا والجراثيم الضارة بأشعة الليزر يجعلها في مستوى تفاؤلات كثيرة لمستقبلها في هذا المجال الحيوي .

### 15- علم الأرصاد :

كون نفاذ وامتصاص أشعة الليزر معتمداً على الطول الموجي المنبعث ( أي نوع الليزر ) ، فإذا أخذنا شعاع ليزر غاز ثاني أكسيد الكربون ذا طول موجي 10.6 ميكرومتر ، فإن نفاذ وامتصاص حزمة هذا النوع تعتمد بقوة على حجم وتوزيع القطرات المائية والبلورات الثلجية في الجو ، لذا فإن هذا النوع من الليزر يمكن الاستفادة من خدماته بكل سهولة لدراسة التركيب الميكروسكوبي الدقيق والتركيب الخارجي لتكون الغيوم فيما يخص علم الأرصاد .

### 16- علم الفلك :

من المعروف أن التشتت أو التفريق الصغير جداً لحزمة الليزر يطور ويحسن القياسات للمسافات بين النجوم وحركتها ، خصوصاً كون أحد أنواع الليزرات يملك طول موجي معين له القدرة على النفاذ من الجو إلى الفضاء الفسيح وبأقل أمتصاص من مكونات الجو الأرضي ولهذه الصفة أهمية في الاتصالات الفضائية .

### 17- علم طبقات الأرض :

قدرة الليزر على اختراق الصخور لأعماق طويلة عن طريق تبخير مكوناتها ، هذا البخار المتصاعد يوجه في نفس خط الحفر إلى جهاز مطياف Spectroscope ، لمعرفة مكونات الصخور من العناصر المختلفة والنسبة المئوية لتواجدها ، والميكانيكية الرئيسية في استعمال الليزر لمعاملة المواد هي العملية الثنائية في الإذابة والتبخير . تصرف الطاقة الشعاعية الساقطة على سطوح المواد بتركيز حزمة الليزر بأربع طرق :

- 1 ( جزء من الطاقة يعكس ويفقد .
  - 2 ( تستعمل أكثر الطاقة المتبقية لذوبان المعادن .
  - 3 ( يستخدم جزء صغير نسبياً من الطاقة لتبخير السوائل المعدنية .
  - 4 ( يوصل الجزء الأصغر من الطاقة إلى المعادن غير الذائبة على شكل حرارة .
- يمكن استخدام الليزر في المناجم للتعرف على مكونات الصخور من المعادن المختلفة، وكذلك من الممكن الاستفادة

منه في حفر الآبار البترولية والكشف عن كميات ومعدلات وجود البترول والمواد الأخرى المصاحبه لها ، وأعماقها الأرضية ، ونوعية طبقات التربة.

### 18- تصنيع المواد

ليزر الياقوت ، وليزر الياج ، وليزر الزجاج ، وليزر ثاني أكسيد الكربون ، والأرجون . فطريقة الحث في الليزرات الثلاثة الأولى تتم بالضخ الضوئي ، أي تستخدم مصادر ضوئية متوهجة ذات قدرات عالية في إثارة موادها وتحفيزها على بعث شعاع الليزر . أما الليزرين الآخرين فطريقة الحث فيهما بالضخ الكهربائي أي تستخدم أقطاب كهربائية تحت جهد عالي في تأين الغازات المستخدمة ، وبالتالي إثارة ذراتها وتحفيزها على إشعاع الليزر أو ما يعرف بالحصول على التعداد المعكوس ، المبدأ الأساسي في الحصول على شعاع الليزر من المواد .

#### 1 ( أجهزة الليزر مع معاملة المواد :

يستخدم الليزر في عمليات تصنيعية عديدة أبدى فيها كفاءة عالية في رفع الإنتاج وتقليل التكلفة من جراء السرعة العالية في الإنجاز ، وهبوط معدلات الضياع والفقدان ومن الأجهزة والوحدات الشائعة الاستعمال حالياً ، نذكر منها ما يلي :

#### أ) وحدة القطع والحفر :

تستعمل هذه الوحدة لقطع وحفر المواد التالية : المعادن بأنواعها ، والمواد البلاستيكية، والخزف أو السيراميك ، والأنسجة الكيميائية ، والأقمشة المختلفة ، وحتى المواد الزجاجية عندما يطلى سطحها بطبقات من المواد الماصة للإشعاع الضوئي مثل الكربون .

#### ب) وحدة التشذيب :

في عمل الدوائر الإلكترونية المتناهية في الصغر يجري ترسيب المواد الموصلة والعازلة على رقائق من المواد نصف الموصلة للتيار الكهربائي مثل السيليكون والعقيق والخزف ومن ثم تسلخ الزوائد من الرقائق الدقيقة بين الدوائر الإلكترونية وتفصل عن بعضها لإعطاء الصيغة النهائية للدائرة الإلكترونية .

### 19- الليزر في التصوير الشبحي الهولوجراف

#### أولاً : مبادئ وأهميته

استخدام أشعة الليزر في التصوير الشبحي المتكامل المجسم بأبعاده الثلاثة : تعتبر القدرة على الرؤية المجسمة إحدى الخواص الفريدة التي تملكها العين عند الإنسان ، والليزر فتح المجال للقدرة على التصوير المجسم ، لما يمتلكه من صفات غير عادية في خصائص شعاعه ، أهمها في هذا المجال هي شدته وترباط موجاته المنبعثة في الزمان والمكان أو ما يعرف بالترباط الموجي لإشعاعاته . وقد عرف هذا العالم الجديد باسم الهولوجراف وهذا تعبير مركب من كلمتين يونانيتين الأصل هي هولو ... وجراف ومعناها التسجيل المتكامل ، وفي الواقع ليس تصويراً بمعنى التصوير التقليدي (الفوتوغرافي) بل إظهاراً وتسجيلاً متكاملًا للجسم بحيث لا نفرقه عن أصله ولا نميزه عن حقيقته إلا إذا قيل لك .

عندما ترى الهولوجرام لجسم ما فإنك تجد التفاصيل الدقيقة ، وتستطيع أن تتفحصه من كل الجهات وباختلاف الزوايا كأنك ترى شبحاً مجسماً في الفضاء وإذا هممت بتلمسه انبرى لك فضاء فارغاً وتصعقت الحقيقة لأول وهلة بأنها خيالاً مجرداً ، لا حياة فيه ، ولا تملك إلا أن تتساءل كيف حيث هذا ؟

أما في الهولوجراف فإنك ترى كل الجسم وعندك متسع من الوقت لفحصه ودراسته من كل الجوانب والاتجاهات لترى حقائق أخرى قد غابت عنك في واقعها . يسحرك هذا العالم ويدخلك عالماً آخرًا متمزج فيه الصورة والخيال .

لا حاجة في الهولوجراف لاستخدام العدسات ، بل نحتاج إلى شعاع الليزر في أبسط أشكاله ، وشفافة وحساسية لضوء الليزر مع مرآة عاكسة . يقسم شعاع الليزر إلى قسمين : القسم الأول يسمى بشعاع الجسم حيث يتجه إلى الجسم نفسه وينعكس منه حاملاً في طيات أمواجه التفاصيل الكاملة له على صيغة التغييرات الحادثة في أطوار وسعات الموجات والجزء الآخر من الشعاع والمسمى بالشعاع الأصيل يعكس بمرآة ليلتقي مع الجزء الأول على الصفيحة الحساسة والتي تسمى بالهولوجرام ومن تداخل هاتين الحزمتين . تتكون على الصفيحة الحساسة دوائر مركزية وخطوط متشعبة لا تمت بصلة للجسم المصور ولكننا إذا أمعنا النظر في داخلها فسندرك عالماً آخر تجد فيه الجسم المصور يحتل مكاناً بارزاً وإن ثبتت الصفيحة الحساسة ووجهت عليها الإضاءة الملائمة برز الجسم بأبعاده الثلاثة وبشجيته المذهلة مرتكزاً في الفضاء الفارغ .

ولو أردت أن تكون نفس هذه الصورة بالطرق الفوتوغرافية العادية لوجدت أنك بحاجة لأخذ ملايين الصور وبزوايا مختلفة لتعطي كامل التفاصيل الدقيقة ، وطبعاً من المجال جمعها سوياً .

والأغرب من ذلك لو أنك حطمت الصفيحة الحساسة ( الهولوجرام ) إلى قطع صغيرة متناثرة سوف تجد في كل قطعة منها الصورة الشبكية نفسها كأن شيئاً لم يتغير فيها ولكنك لو دقت النظر سوف تجد بأن إحدى الزوايا مفقودة .

### ثانياً : تطبيقات الهولوجراف

يمكن إيجاز أهم تطبيقات الهولوجراف في النقاط التالية : -

إنه استقطب خيال الكثير من المهندسين والباحثين في التطبيقات الصناعية ، المدنية منها والعسكرية فبوساطة ، الهولوجراف تخزن المعلومات في الكمبيوتر وبذلك ترتفع كفاءة وسعة وسرعة خزن المعلومات في ذاكرة العقول الإلكترونية

● في المجاهر ( الميكروسكوبات ) يمكن استطلاع ورؤية الخلايا الحية وبأبعادها المجسمة الثلاثة ، وبذلك تعطي العلماء والباحثين ولأول مرة القدرة على رؤية الخلايا والجسيمات الدقيقة والتي لا ترى بالعين المجردة ، بوضعها الطبيعي المجسم .

● تصوير الأجزاء المعدنية والميكانيكية في السبائك والمواد المطاطية المختلفة ، وتدرس بذلك عيوب التصنيع وجودة الآلات ، بالإضافة إلى مراقبة التغييرات الحادثة نتيجة الاستعمال والاستهلاك وهي تعطي مؤشرات الخطورة قبل وقوعها .

● لمنع السرقات للتحف والآثار الثمينة أو المجوهرات النادرة والأعمال النفيسة فإنه تصور بالهولوجراف ، وعرض صورها المجسمة بدلاً منها وهذه الصور لا تفرق عن أصولها في كل دقيقة من دقائق تكوينها ، وهذه ، كما لا يخفى ، معالجة رائعة ومذهلة لسرقات التحف النفيسة .

● يستفاد من طريقة الهولوجراف في الطرق الدولية داخل المدن في إظهار الإرشادات المختلفة لسائقي العربات على شكل كلمات مجسمة للتدليل عن إغلاق لبعض الممرات ، أو استخدام مسارات مختلفة منعاً لوقوع الحوادث ، ويستعاض عن النشرات الراديوية بذلك .



## 3 Laser Applications.

The number of applications of lasers is enormous, and it is not possible to explain **all** of them here. In this chapter, the **applications are divided into groups**, and our hope is that **with time we will fill the missing information on most of the well known applications of lasers**. Some applications are already described in details, such as:

### 3.1 Industrial Applications

Industry accepted the laser as a tool soon after the laser was invented in 1960. At first the laser was used for **alignment and measurements**, but with time applications using high power laser beams became more common.

The **main industrial applications** are:

#### 3.1.1 Accurate measurements (Distance, Movement, Interferometry).

Since laser radiation is **electromagnetic radiation**, **traveling at the speed of light**, very accurate measurements can be performed with lasers.

Because of its high speed (the speed of light ( $c$ ) is the ultimate speed ...), measurements of high speed moving objects is not a problem, and the information is available in (almost) real time.

- **Measurement of the distance from Earth to the moon:**

One of the known precise measurements with a laser was measuring the distance from Earth to the moon. The astronauts who landed on the surface of the Moon left there a **corner cube** (a system of three perpendicular mirrors that reflect light in the same direction where it came from).

A pulsed laser beam was sent from Earth to the moon and was reflected from this corner cube back to Earth.

The travel time of the pulse was recorded.

From the known speed of light ( $c$ ) the distance was calculated, with accuracy of tens of centimeters (!).

#### 3.1.2 Straight line marking, or plan of reference.

Many daily applications require a **precise reference line for alignment**.

**Examples are:**

- Laying pipes of gas, water, electricity, etc.
- Digging tunnels under-ground (such as the one under the **English Channel** between England and France).

- Alignment of mechanical systems.
- Marking spots for pointing invisible radiation from another laser (such as Nd-YAG or CO<sub>2</sub> lasers). The visible laser radiation is aligned parallel to the invisible radiation, such that it mark the place where the invisible beam is pointing.
- **Marking a reference plane for construction:**

By using a **vibrating (or rotating) mirror** to reflect a visible laser light, a perfect plane is defined in space. The mirror is vibrating around one axis, so the light is reflected into consecutive angles continuously, thus defining a perfect plane. Since the vibration of the mirror is at a frequency greater than the persistence of vision in the brain, the viewer see a plane of light. This plane helps aligning walls, sealing, etc. in industrial construction.

### 3.1.3 Material working

**The main advantages of lasers for material processing are:**

- **Very high accuracy** in the final processed products that can be obtained without the need for polishing.
- **No wearing of mechanical tools**. Mechanical tools change their dimensions during the working process, and require constant measurements and feedback to adapt their position to original plan in computerized instrumentation.

**Material processing** include many kinds of processes. A partial list include:

- **Cutting** - The laser can be a very precise cutting tool. High power lasers are used for cutting steel, while other lasers are used to cut fabrics, rubber, plastic, or any other material.
- **Welding** - Combining (fusing) two materials together. By heating the materials near the connecting region, the materials melt locally, and fuse together.
- **Hardening** - By heating specific areas of the material, most metals can be hardened most of the metals. Even **local hardening** of specific part of a tool can be done by local irradiation.
- **Melting** - Absorption of laser beams caused a rise in temperature. Since very high power can be transferred to materials in a very short time, melting can be easily done.
- **Evaporating** - Used to ablate material (transfer it into the gas phase).
- **Photolithography** - specially in the semiconductor industry. Very delicate

s

hapes can be created in materials which are used for masks in photolithography. Special materials respond to light at specific wavelength by changing their properties. Thus it is possible to remove parts of the material with very high precision (in micrometer range).

- **3-D Laser measurements** - With the help of a scanning laser, it is possible to obtain the information about a shape of a three-dimensional object and put it in the computer.
- **3-D Stereo lithography** - Similar to photolithography, but the laser is used to create three dimensional sculpture of the information stored within a computer.

A combination of the last two applications enable **creating 3-D models**. Even statue of people were build with high accuracy using these techniques.

### 3.1.4 Spectral analysis.

We saw in **chapter 2**, and **chapter 5**, that the entire lasing process is based on **absorption** and **emission** of photons at certain specific wavelengths.

The wavelength emitted from the laser is **monochromatic**, and its linewidth is very narrow. Thus, the laser can be used for **controlled excitation of molecules**.

Especially useful for this are the tunable lasers, whose wavelength can be precisely tune to excite specific molecule.

## 3.2 Medical Applications

There are many medical applications of lasers, and there are different ways to classify them into **groups**:

According to the **organ to be treated by the laser**, such as: Eye, General Surgery, Dentistry, Dermatology, Blood vessels, Cardiac, etc.

According to the **type of laser used for treatment**, such as: CO<sub>2</sub>, YAG, and Argon.

According to the **type of treatment**, such as diagnostic, surgery, connecting blood vessels.

The classification used here is basically according to the **type of treatment**, with comments on suitable lasers used for each application:

**3.2.1 Lasers in medical surgery.**

**3.2.2 Lasers in diagnostic medicine, and in combination with drugs.**

**3.2.3 Lasers for specific applications: Soft lasers.**

When using lasers for medical treatments, a good understanding of the **interaction between specific laser radiation with specific biological tissue** is required.

**3.2.1 Lasers in Medical Surgery**

Almost every medical surgery in which a **removal of tissue** is required or a **cut needs to be made**, can be done with a laser.

In general, the results of surgery using lasers are better than the results using a surgical knife.

### The Advantages of Laser Surgery:

- **Dry field of surgery**, because laser energy seals small blood vessels.
- **Less postoperative pain**, because of the sealing of nerve ends.
- No contact with mechanical instruments, so **sterilization** is built in.
- **Clear field of view**, because no mechanical instrument blocks it.
- Possible **wavelength specific reaction** of specific colors of biological tissue.
- Possibility to perform **microsurgery under a microscope**. The laser beam passes through the same microscope.
- Possibility to **perform surgical procedures inside the body without opening it**, using optical fibers to transmit the laser beam.
- The laser can be used as a **precise cutting tool**.
- It can be **controlled by a computer**, and operate with a very small area of effect **under a microscope**.

### 3.2.2 Lasers in Diagnostic Medicine, and in combination with Drugs:

#### Diagnosics of cancer cells using Fluorescence, and Photo Dynamic Therapy (PDT)

One of the biggest problems in medicine today is to find a **cure for cancer**.

There are many treatments for cancer to destroy the cancer cells, such as:

Disectomy of the infected organ.

Radioactive irradiation.

Heat treatment.

All these treatments improve the chance of cure in some cases, but the "magic" medicine has not yet been found. Since there is no solution yet, the medical professionals are looking for new ways to solve the big problem of cancer.

### 3.2.3 Soft lasers

Most of the medical laser applications were until recently based on the **thermal effects** caused by the electromagnetic radiation which was absorbed in the biological tissue.

In the last few years, some new applications are using low power **lasers with output power less than 1 Watt**.

Some of the effects of these low power levels on the biological tissue is not thermal, and in effect the mechanism of interaction is not yet clear.

It is sometimes referred to as **Biostimulation**, which does not explain a lot.

### **3.3 Military Applications**

Since the invention of the laser, its potential military uses were exploited.

Large number of projects on lasers were done in secret laboratories, and many years passed until the public was notified about these projects.

In the last few years, with the fall of the "Iron Curtain", and the creation of collaboration between the super-powers, the public found about some of these big projects that cost so much money.

We shall concentrate on some of the simplest and most known applications, such as:

#### **3.1 Laser Range-finder**

**Measuring distances** with high speed and high accuracy was the immediate military application after the laser was invented. Since the laser beam is **electromagnetic light**, it is **traveling in space with known velocity** (the velocity of light  $c$ ).

By sending a short laser pulse to the target and measuring the time it take the beam to arrive at the target and reflect back to the sender, it is easy to calculate the distance. Measuring distances with high accuracy is important for military applications such as:

Measuring the distance to a shooting target for artillery and missiles. Navigation.

Numerical Example:

How much time will the laser pulse travel, when it hit a target at a distance of 1.5 kilometer?

$$t = s/c = 3,000 \text{ [m]}/3 \cdot 10^8 \text{ [m/s]} = 10^{-5} \text{ [sec]} = 10 \text{ [micro-sec]}$$

This time is well within the response time of standard electronic equipment.

#### **3.3.2 Laser Target Designator**

The laser is used to **mark targets for attack by "smart" artillery and guided missiles**.

**The properties that make the laser so attractive as laser designator are:**

The laser beam advance great distances in a straight line.

The laser beam propagate at very high speed (speed of light).

It is possible to **modulate the laser beam to include information for identification**.

A soldier in the field, or a flying vehicle can be used to send a laser beam on the target.

The laser is designed to send a series of pulses in a specific pattern (code) of pulses of invisible light.

cial detecting systems are locked on these specific pattern of laser pulses, and guide the "Smart Bombs" to hit the marked target.

An example showing several laser designator system are shown in figure 9.1.

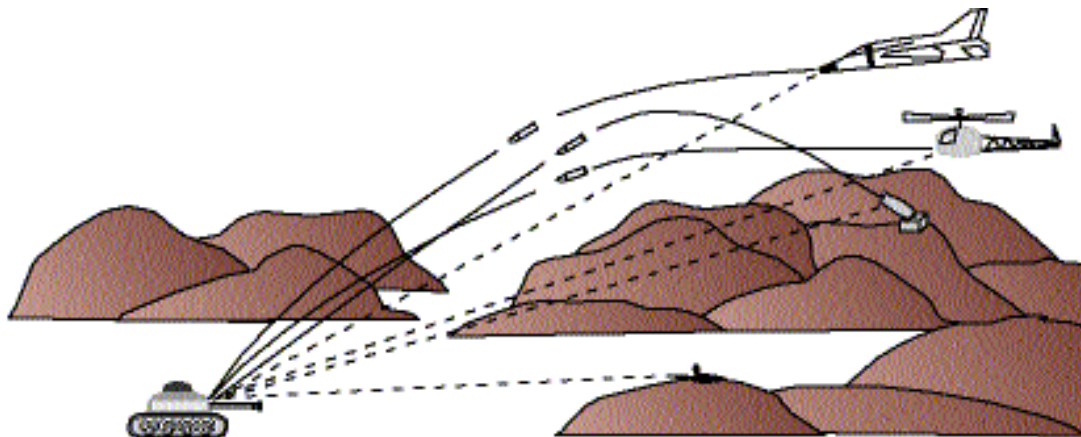

Figure 9.1: Laser Designator systems in the Battlefield.

### 3.3.3 Laser weapons ("Star War").

A lot was written on the **Strategic Defense Initiative (SDI)** of the US government.

This futuristic project was named by the public "**Star Wars**".

The idea behind this initiative was to **build high power devices** that can send beams over very big distances in a very high accuracy and very high speed.

These high power devices were supposed to destroy the USSR missiles above their launching sites right after this launch. Since these missiles were supposed to carry nuclear weapons, it was not possible to let them arrive above Europe or the US. By destroying the missiles at the launch zone a great damage would be caused to the attacker, so such defense system was a threat to the other side.

### 3.3.4 Laser blinding for man and sensitive equipment.

A simple and very promising project, which is being developed at many sites all over the world, is **laser system for blinding enemy soldiers and their optical equipment**.

The **power required is not specially high**, because of the high sensitivity of our sight system, and the high sensitivity of the optical detection systems in use at the battlefield.

**The operation of blinding laser system is simple:**

**The laser beam is used to scan the space in front of the military troops, blin**



### **ding enemy soldiers and their equipment.**

As can be seen in the [Appendix](#), optical power density higher than the safe level can cause blindness (temporary or permanent) to humans, and saturation or damage to sensitive optical equipment.

## **3.4 Daily applications**

Since the daily applications of the laser are the most familiar to us, they are described in more details. They are classified as: **Laser at home**, which include:

### **3.4.1 Compact Disc and CD-ROM**

#### **Optical storage of digital information.**

#### Preface

Since the beginning of history, man searched for means of storing information, in order to inherit knowledge to following generations.

At first the cave-man marked the hunting drawings on the cave walls.

Then came shard boards, parchment scrolls, paper, printing, and now the magnetic recordings.

**Magnetic recordings** is used on many devices such as: Tape recorders, computer tapes for storing information in big computers, computer diskettes, and hard drives for storing information in personal computers (pcs).

As society developed more, the amount of information is growing at an exponential rate. People are trying to find better ways to store information, and the current trend is toward:

### **3.4.2 Laser Printer**

Everyone heard about laser printers, and most offices are using laser printers for printing their documents. We are all aware of the **quality of the printing out of a laser printer**, but few knows to answers questions about the operation principles of the laser printer:

What is the role of the laser in a laser printer?

What is the difference between a laser printer and a photocopy machine?

Can the same system be used for printing documents from a computer and photocopying documents?

What are the advantages of the laser printer compared to the dot printers?

The following pages will try to answer such and similar questions by explaining about the laser printer, and the physical principles underlying its operation.

### **3.4.3 Optical Storage of Information**

already saw the **Compact-Disc, or CD-ROM in section 9.4.1** as a way to store information and read it optically. There are storage devices which act like magnetic hard disc drives of a computer, but store the information optically. Both writing the information on the optical disc and reading it are done using lasers.

These devices allow rewriting information on the optical disk thousands of times, unlike CD, which is write-once device.

New devices, which are now at a research stage, are based **on holographic writing and reading** of information (see chapter 10). These devices **store a complete page as an image**, unlike the storage of bits in standard storage devices.

### 3.4.4 optical computer - processing information at the speed of light!

Electronic computers are limited by the speed of current flow through the wires inside the computer. By using **pulses of light instead of electrical currents** it is possible to **increase by orders of magnitude the speed of the computers**. In electronics, it is possible today to put millions of transistors into one **integrated circuit (IC)**.

For optical computers, similar circuits are needed to be developed, and they are called **integrated optics (IO)**. This is a new research subject and there are not yet commercial products of optical computers. In the laboratory, scientists have demonstrated simple operations of edition and multiplication, but it will probably take more than 10-20 years until such products will be available.

### 3.4.5 Bar code scanner.

With increased automation in every-day life, there was a need for a **standard automatic identification system for consumer products**. Many automatic systems for identifying products are based on **optical systems**. Such systems are based on a **beam of light, which scan a bar code on the product**. The reflected light is read by an optical system.

**Bar code** is a code based on a series of dark and bright bands with specific distances between them. It is made by **writing dark bands on white background**. Usually the bar code appears on a paper label. **In a common bar code the information is coded in one dimension**: the **width** of the dark and bright bands. The **length** of the bands is just for easy reading and does not contain any

meaningful information.

### **3.4.6 Holograms on credit cards and other valuable products to avoid forgery.**

Holography is described in chapter 2.

Here we shall just mention one of the expanding application of laser in everyday life.

Since we now know how to **mass-produce holograms** that can be seen without using a laser, people are using these holograms in many applications.

The production of the master hologram requires sophisticated equipment and special knowledge. This makes them ideal in **preventing forgery**.

The laser is used only in the first production stage of the master hologram

#### **Examples for this use of holograms are on:**

- Every "Visa" credit card.
- "Microsoft" software.
- Special bank notes.

Applications in the future will probably include all kinds of identification cards.

### **3.4.7 Optical Fiber Communications**

Each channel in communications needs a **bandwidth** (range of frequencies around the central transmission frequency).

**Optical frequencies** (in the visible or Near-Infra-Red spectrum region) are very high frequencies ( $10^{14}$ - $10^{15}$  [Hz]).

The **bandwidth of voice communication** over phone lines is about 10 [kHz].

Thus, the number of phone conversations that can be send over optical communications system is measured in enormous numbers.

Diode lasers can be modulated at speeds of tens of Giga-Hertz ( $10^{10}$  [Hz]). and their light can be transmitted over tens of kilometers of optical fibers without the need for amplification.

Thus, Optical fiber communications provide the perfect solution for reliable high volume communication. This subject need its own Web site, so we shall just mention here a few facts.

#### **Advantages of Optical Fibers:**

- Wide bandwidth.

## Laser Physics

---

- Immunity from electrical interference.
- Low weight.
- Low cost.
- More secure transmission.

Using optical fibers instead of the metal wires that transmit electrical signal have so many advantages, that all the new communication lines are made of optical fibers.

**In one optical fiber to the home, all the communications need can be fulfilled:**

Phone, television, radio, cable TV, computer communication, etc.

### 3.4.8 Free Space Optical Communications

The very high modulation speed of [Diode Lasers](#) enables **direct line of sight optical communication at very high speed**. **The main applications of free space optical communications are:**

- **Communication between satellites in space** which can transfer information at a bit rates of  $10^{10}$  bits per second. Thus tens of thousands of phone conversations can be transmitted simultaneously.
- **Military use** of free space optical communication channels are used especially in the battle field, when it is not practical to have fiber optics links. The communication is based on direct line of sight, and provides a **secure link** because of the very narrow divergence of the laser beam. The advantages of optical communications were described in [section 3.4.7](#).

### 3.4.9.0 Lasers in Art and entertainment

Using **lasers that emit in the visible spectrum range**, it is possible to create impressive visual effects. When a laser beam pass through a region of humidity, smoke, or any other small particles in the air, the **scattered light** can be seen by observers from all sides.

In big outdoor shows, when the effect need to be seen from a distance, it is possible by moving a small optical element (such as mirror) to move laser beams over large area.

For entertainment it is common to use lasers which emit few laser wavelengths. First each color is separated, using prisms, to create many laser beams of diffe

rent colors. Using small **vibrating mirrors**, controlled by a computer, it is possible to move each laser beam very rapidly, and create moving colored images. Since our vision is based on seeing the image a little time after it has disappeared, we see a full picture created by laser beam, although the laser beam illuminates each point for a brief period of time.

The first devices were used to create **two dimensional moving pictures on screens**, but the new devices are used to create **three dimensional moving sculptures in space** (with small particles in it). Using emitted laser powers of few watts, it is possible to create **big moving images**, in free space, an impossible task to create by other means.

### 3.4.10 Holograms for exhibitions and museums

(Details about holography and its applications are described in chapter 10). Holograms allows us to see three dimensional images. Thus there are special holography museums which show holograms as an art by itself.

A more advanced use is to **show holograms of rare exhibits**, which can be damaged by exposing to the public. Such exhibits include:

Archeological exhibits which need to be kept at special light, temperature and humidity conditions.

Very expensive items, which can be stolen or damage by the public.

Rare items which can not be exhibited in every museum, but their holograms can. Good hologram contains all the information included in the original object. Once **color holography** will be developed, many special exhibits will be available to be seen at many museums.

### 3.4.11 Kinetic sculptures.

**Visible light** is used to create visual effects.

Using lasers in the visible spectrum, with the help of optical elements which cause reflection **refraction**, and dispersion, it is possible to **create three dimensional sculptures which are moving in space**. In order to **see the laser beams in space** we need a **medium which scatter light in all directions**. The standard medium is **smoke** which contains very small particles suspended in the air. When using higher power visible lasers, it is possible to see the reflections from the particles in "standard" air, without the use of smoke.

The best lasers for these application are the [Argon Ion](#) and the [Krypton Ion](#)

### lasers.

A **"wall" (plane) of light** can be easily created by a rotating or vibrating mirror. By using multiple rotating and/or vibrating mirrors, controlled by computers, it is possible to design complicated shapes which appear in space.

### 3.5 Scientific/Research Applications

#### 3.5.1 Spectroscopy.

Every material has its own characteristic absorption and emission spectrum. By selective excitation using specific wavelengths, it is possible to identify materials with high certainty, even if only small traces exist.

**Spectroscopy** is used in the research of molecules by optically exciting the molecules. It is one of the most important tools in the research of the structure of matter.

The laser allows the use of **definite controlled wavelengths**, which results in a **very high resolution measurements**. Increasing the accuracy of the determination of the wavelength allows a distinction between smaller details in the material structure.

**Photo-chemistry** is the science of chemical changes which are the result of light.

#### **Examples are:**

- "Tanning" of the skin in the sun light.
- **Photosynthesis in plants.**
- The process of **vision** within the retina cells of the eye.
- **Induced fluorescence** is a very sensitive process, which allows selective excitation of specific energy levels in a specific molecule. This process is used in **forensic science** to identify trace residuals of molecules.

#### 3.5.2 Inertial Fusion by laser

#### **Equivalence between mass (m) and energy (E):**

**Mass and energy are related by the mathematical formula:  $E = mc^2$**

This well-known formula was discovered by **Albert Einstein** in 1905, and he expl \_\_\_\_\_



ained the equivalence between mass and energy using this relation.

**Every reaction, which results in products with total mass less than the original mass, releases energy. The amount of energy released is equal to the mass difference times the square of the velocity of light.**

The amount of energy per unit mass, which is released by the nuclear fusion reaction, is millions times higher than the chemical energy released by burning coal or oil.

The first artificial use of fusion energy was in the **Hydrogen bomb** (October 1952). Since then, scientists are trying to control the nuclear fusion reaction; in order to make controlled use of the energy released.

### 3.5.3 Lasers which emit very short pulses ( $10^{-15}$ - $10^{-18}$ [sec]).

Very short pulses are a new tool for research.

#### **Applications of very short pulses:**

- They can be used to study rapid processes. Illuminating the process at short intervals, and taking a picture.
- **Optical communications.** The shorter the pulse, the greater the number of pulses that can be send in a second. This number determine the amount of information that can be transmitted in a given time.

### 3.5.4 Laser cooling of atoms.

All atoms in nature are moving because they are at a temperature higher than 0 [°K], thus they have **thermal energy**. **At low temperatures, it is possible to almost stop atoms by using the momentum of the photons of the laser radiation.**

#### **Explanation:**

A beam of laser light moving in the opposite direction of a beam of atoms can be made to interact with each other in such a way that the atoms absorb photons from the laser beam. The process occurs when the photons energy (which is determined by the photon frequency) is exactly equal to the energy difference between energy levels of these atoms.

When the atom is in motion, then by the **Doppler effect** this atom "sees" a slightly different frequency of the incoming photons. By using a few beams from

opp

osite directions, it is possible to stop the movement of atoms. The **frequency of the laser beam** is chosen such that it is very close to the absorption frequency of the atom, but not identical to it. Each time the atom starts to move toward one of the laser beams, the Doppler effect causes the radiation from that beam to be absorbed by the atom, so it returns to its place.

### **3.5.5 Study of the interaction of electromagnetic radiation with matter.**

Electromagnetic radiation can react with matter by many different mechanisms. The research of the mechanisms of interaction between electromagnetic radiation and matter is a very productive research field, which produce many new applications.

- For all the medical applications of the laser this research is of valuable importance.
- For all the industrial material processing applications by lasers this research is of valuable importance.
- We shall mention the advance in recent years of the interaction of electromagnetic radiation with different **biological molecules**, and the potential of **genetic engineering** (changing the gene properties by manipulations on the DNA molecules within the nucleus of the biological cell).

### **3.6 Special applications.**

The applications of lasers are expanding, and many new special applications have been discovered. In the next few sections we shall mentioned briefly just a few of the more common special applications.

#### **3.6.1 Energy transport in space.**

Space stations are planned for the near future. And space opens new possibilities for the human race. The energy for the space station will be collected by big collections of solar cells.

There is an idea to **build such big solar collectors in space**. These solar cells will convert the solar energy into electricity. The electrical energy will be send to Earth in Electromagnetic radiation form as a beam of laser energy.

#### **3.6.2 Laser gyroscope.**

**Gyroscope is an instrument that helps maintain orientation in space.**

In the past the gyroscopes were **mechanical spinning systems**, in which the principle of conservation of angular momentum help keep the device pointing in one direction. These devices were very massive and required motors and maintenance. **Optical gyroscopes** are based on a principle called **Sagniac effect**.

This effect which was discovered at the beginning of the 20<sup>th</sup> century, states that: " An electromagnetic wave which moves in a closed path, which surrounds a finite area, is influenced from the angular velocity of the system which is included in this area".

### **Principle of Operation of Optical Gyroscope:**

**Two laser beams are moving in opposite directions in the same ring path.**

Any change in the direction of the system will cause a difference in the path of these two beams. By using **interferometric measurements** (), it is possible to detect very small changes, so the laser gyroscope is a very sensitive device. There are two kinds of optical gyroscopes, both based on the same principle:

1. **Laser Gyroscope** is a **laser with ring cavity**. The laser cavity is made of three or four mirrors which form of a closed loop.
2. **Fiber Gyroscope** is a similar device, but the beams of the laser light are traveling along a fiber optic, which is in a form of a coil.

### **3.6.3 Fiber laser.**

It is possible to **create a laser action within an optical fiber**. The [active medium](#) is an optical fiber made of impurity atoms embedded in the glass of the fiber core. **The advantages of the fiber-laser are:**

- The optical fiber confine the laser beam within the fiber (the active medium).
- The optical pumping is done by light which is confined within the fiber.

**Fiber-laser can directly amplify an incoming signal of laser light**, without having to transform it to an electrical signal which is then amplified electronically, and transformed back into light.

**The main use of fiber-laser is in optical communication**, where the signal transmitted over long distances (such as over the ocean) need to be amplified along the way. The most known family of fiber laser is the **Erbium (Er) Doped Fiber Amplifier (EDFA)**, which is used in optical communications.

### **Holography**

**In everyday life we see everything in 3-D**, and we accept it as obvious.

However, when we look at a hologram which show a 3-D image of something, we are impressed.

**Holography enables looking at a 3 dimensional scene**, where the perspective and **parallax** are kept as in real life. (**Parallax** is the relative position of the bodies in the picture, as seen from different points of view [Click here to read more about parallax](#)).

The medium on which the 3-D image is recorded is called "**Hologram**"

The name **Hologram** comes from the Greek language, and means "**whole message (picture)**".

Looking at a hologram from different angles, show different perspectives of the scene.

**All the information on the 3 dimensional scene is retained in the hologram.**

Since hologram is based on **interferometry**, it will be explained first:

**What is recorded on the hologram is not the image (as in standard film photography), but the interference pattern created by the waves from all parts of the bodies in the scene.**

**Interference pattern** is created between two beams of light (waves) occupying the same place in space at the same time.

[At the end of Chapter](#) , there are links to holographic Web sites, where nice pictures of holograms can be seen, and more information can be read, especially on commercial products.

---

### **Classifications of lasers into groups,** **according to safety precautions needed:**

The **American National Standards Institute (ANSI)** divides all lasers into four groups according to the risk involved in using them . These **laser hazard classifications** are used to signify the level of hazard inherent in a laser system, and the extent of safety controls required. These range from class I lasers (which are inherently safe for direct beam viewing under most conditions) to class IV lasers (which require the most strict controls).

This division is based on the maximum radiation emitted from the laser which can cause damage. For this, they defined two parameters:

- The **aperture through which the radiation is received.**
- **The distance from the laser** , in which the measurement is done.

**Laser Applications**

Medical applications	Welding and Cutting	Surveying
Garment industry	Laser nuclear fusion	Communication
Laser printing	CDs and optical discs	Spectroscopy
Heat treatment	Barcode scanners	Laser cooling

**Medical Uses of Lasers**

The highly collimated beam of a laser can be further focused to a microscopic dot of extremely high energy density. This makes it useful as a cutting and cauterizing instrument. Lasers are used for photocoagulation of the retina to halt retinal hemorrhaging and for the tacking of retinal tears. Higher power lasers are used after cataract surgery if the supportive membrane surrounding the implanted lens becomes milky. Photodisruption of the membrane often can cause it to draw back like a shade, almost instantly restoring vision. A focused laser can act as an extremely sharp scalpel for delicate surgery, cauterizing as it cuts. ("Cauterizing" refers to long-standing medical practices of using a hot instrument or a high frequency electrical probe to singe the tissue around an incision, sealing off tiny blood vessels to stop bleeding.) The cauterizing action is particularly important for surgical procedures in blood-rich tissue such as the liver.

Lasers have been used to make incisions half a micron wide, compared to about 80 microns for

**Welding and Cutting**

The highly collimated beam of a laser can be further focused to a microscopic dot of extremely high energy density for welding and cutting.

The automobile industry makes extensive use of carbon dioxide lasers with powers up to several kilowatts for computer controlled welding on auto assembly lines.

Garmire points out an interesting application of CO2 lasers to the welding of stainless steel handles on copper cooking pots. A nearly impossible task for conventional welding because of the great difference in thermal conductivities between stainless steel and copper, it is done so quickly by the laser that the thermal conductivities are irrelevant.

**Surveying and Ranging**

Helium-neon and semiconductor lasers have become standard parts of the field surveyor's equipment. A fast laser pulse is sent to a corner reflector at the point to be measured and the time of reflection is measured to get the distance.

Some such surveying is long distance! The Apollo 11 and Apollo 14 astronauts

put

## Laser Physics

---

corner reflectors on the surface of the Moon for determination of the Earth-Moon distance. A powerful laser pulse from the MacDonald Observatory in Texas had spread to about a 3 km radius by the time it got to the Moon, but the reflection was strong enough to be detected. We now know the range from the Moon to Texas within about 15 cm, a nine significant digit measurement. A pulsed ruby laser was used for this measurement.

### **Lasers in the Garment Industry**

Laser cutters are credited with keeping the U.S. garment industry competitive in the world market. Computer controlled laser garment cutters can be programmed to cut out 400 size 6 and then 700 size 9 garments - and that might involve just a few cuts. The programmed cutter can cut dozens to hundreds of thicknesses of cloth, and can cut out every piece of the garment in a single run.

The usefulness of the laser for such cutting operations comes from the fact that the beam is highly collimated and can be further focused to a microscopic dot of extremely high energy density for cutting.

### **Lasers in Communication**

Fiber optic cables are a major mode of communication partly because multiple signals can be sent with high quality and low loss by light propagating along the fibers. The light signals can be modulated with the information to be sent by either light emitting diodes or lasers. The lasers have significant advantages because they are more nearly monochromatic and this allows the pulse shape to be maintained better over long distances. If a better pulse shape can be maintained, then the communication can be sent at higher rates without overlap of the pulses. Ohanian quotes a factor of 10 advantage for the laser modulators. Telephone fiber drivers may be solid state lasers the size of a grain of sand and consume a power of only half a milliwatt. Yet they can send 50 million pulses per second into an attached telephone fiber and encode over 600 simultaneous telephone conversations (Ohanian).

### **Heat Treatment**

Heat treatments for hardening or annealing have been long practiced in metallurgy. But lasers offer some new possibilities for selective heat treatments of metal parts. For example, lasers can provide localized heat treatments such as the hardening of the surfaces of automobile camshafts. These shafts are manufactured to high precision, and if the entire camshaft is heat treated, some warping will inevitably occur. But the working surfaces of the cams can be heated quickly with a carbon dioxide laser and hardened without appreciably affecting the remainder of the shaft, preserving the precision of manufacture.



### **Barcode Scanners**

Supermarket scanners typically use helium-neon lasers to scan the universal barcodes to identify products. The laser beam bounces off a rotating mirror and scans the code, sending a modulated beam to a light detector and then to a computer which has the product information stored. Semiconductor lasers can also be used for this purpose.

### **Laser Fusion**

Laser fusion attempts to force nuclear fusion in tiny pellets or microballoons of a deuterium-tritium mixture by zapping them with such a high energy density that they will fuse before they have time to move away from each other. This is an example of inertial confinement.

Two experimental laser fusion devices have been developed at Lawrence Livermore Laboratory, called Shiva and Nova. They deliver high power bursts of laser light from multiple lasers onto a small deuterium-tritium target. These lasers are neodymium glass lasers which are capable of extremely high power pulses.

### **Nova Laser System**

Nova is the name given to the second generation laser fusion device at Lawrence Livermore Laboratories. It employs lasers ten times more powerful than the Shiva laser fusion device and will attempt to reach the breakeven point for fusion. Nova makes use of ten lasers which are focused on a 1 mm diameter target area, dumping 100,000 joules of energy into the target in a nanosecond.

As of 1994, Nova has reached the Lawson criterion, but at a temperature too low for fusion ignition.

### **Particle Beam Fusion**

If a high energy beam of electrons or other particles can be directed onto a tiny pellet or microballoon of deuterium-tritium mixture, it could cause it to explode like a miniature hydrogen bomb, fusing the deuterium and tritium nuclei in a time frame too short for them to move apart.

### **Compact Disc Audio**

Analog sound data is digitized by sampling at 44.1 kHz and coding as binary numbers in the pits on the compact disc. As the focused laser beam sweeps over the pits, it reproduces the binary numbers in the detection circuitry. The same function as the "pits" can be accomplished by magneto-optical recording. The digital signal is then reconverted to analog form by a D/A converter.

The tracks on a compact disc are nominally spaced by 1.6 micrometers, close enough that they are able to separate reflected light into its component colors like a diffraction grating.

This is an active graphic. Click on any bold text for further details.

### Laser for Compact Discs

The detection of the binary data stored in the form of pits on the compact disc is done with the use of a semiconductor laser. The laser is focused to a diameter of about 0.8 mm at the bottom of the disc, but is further focused to about 1.7 micrometers as it passes through the clear plastic substrate to strike the reflective layer.

The Philips CQL10 laser has a wavelength of 790 nm in air. The depth of the pits is about a quarter of the wavelength of this laser in the substrate material.

This is an active graphic. Click on any bold text for further details.

### Laser Cooling

Starting in about 1985 with the work of Steven Chu and others, the use of lasers to achieve extremely low temperatures has advanced to the point that temperatures of  $10^{-9}$  K have been reached. If an atom is traveling toward a laser beam and absorbs a photon from the laser, it will be slowed by the fact that the photon has momentum  $p = E/c = h/\lambda$ . If we take a sodium atom as an example, and assume that a number of sodium atoms are freely moving in a vacuum chamber at 300K, the rms velocity of a sodium atom from the Maxwell speed distribution would be about 570 m/s. Then if a laser is tuned just below one of the sodium d-lines (589.0 and 589.6 nm, about 2.1 eV), a sodium atom traveling toward the laser and absorbing a laser photon would have its momentum reduced by the amount of the momentum of the photon. It would take a large number of such absorptions to cool the sodium atoms to near 0K since one absorption would slow a sodium atom by only about 3 cm/s out of a speed of 570 m/s. A straight projection requires almost 20,000 photons to reduce the sodium atom momentum to zero.

A conceptual problem is that an absorption can also speed up an atom if it catches it from behind, so it is necessary to have more absorptions from head-on photons if your goal is to slow down the atoms. This is accomplished in practice by tuning the laser slightly below the resonance absorption of a stationary sodium atom. From the atom's perspective, the headon photon is seen as Doppler shifted upward toward its resonant frequency and it therefore more strongly absorbed than a photon traveling in the opposite direction which is Doppler shifted away from the resonance. In the case of our room temperature sodium atom above, the incoming photon would be Doppler shifted up 0.97 GHz, so to get

## استطارة رامان

استطارة رامان عندما يتم تسليط الضوء على الجزيئات، يتشتت الضوء بواسطة تلك الجزيئات. معظم موجات الضوء المستطارة يكون لها نفس تردد الضوء الساقط ولكن بعض الموجات سيكون لها تردد مختلف بسبب التفاعل بين تذبذب الضوء والاهتزاز الجزيئي. ظاهرة تشتت الضوء مع تغير التردد تسمى استطارة رامان. نظرًا لأن تغير التردد هذا خاص بالاهتزاز الجزيئي والفونون في البلور، فمن الممكن تحليل تكوين المواد أو

معلومات الشبكة البلورية عن طريق تحليل طيف الضوء المستطار لرامان. طريقة التحليل هذه تسمى مطيافية رامان. وللتحليل في المنطقة المجهرية يستخدم مطياف رامان، حيث يتم دمج مطياف رامان مع ميكروسكوب ((مطيافية رامان الميكروية

### Scattering of light by molecules

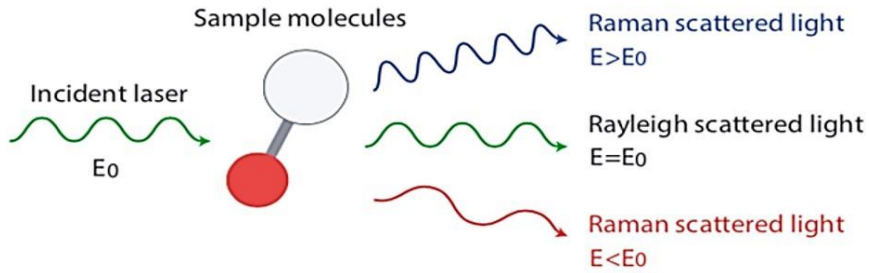
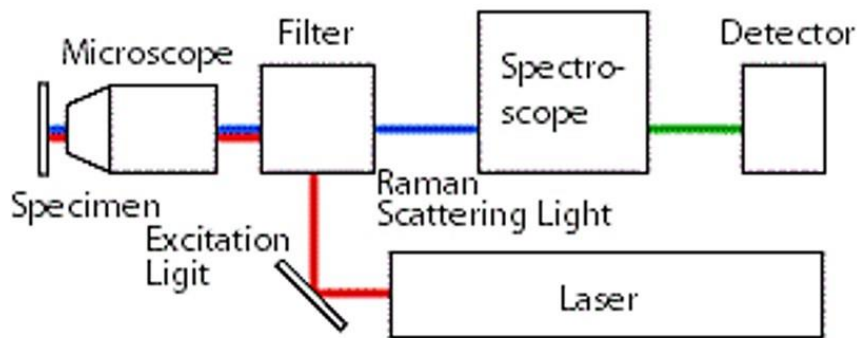

Fig.1

اعلانت جوجل

في الآونة الأخيرة، أصبح من الشائع جدًا قياس طيف رامان لجميع النقاط في المنطقة وإعادة بناء الصورة المجهرية في نطاق طيف معين لمعرفة توزيع المعلومات الطيفية. إن أداة رامان التي لديها القدرة على إظهار صورة رامان الطيفية تسمى مجهر رامان.

ونظرًا لأن قياس أطياف رامان في جميع النقاط في المنطقة يستغرق وقتًا طويلاً، فإن بعض صانعي رامان RAMANtouch. وهي أسرع طريقة Nanophoton يعتمدون طريقة التصوير السريع. من بينها، تقنية لديها تقنية مطيافية متعددة القنوات تقيس أطياف متعددة في نفس الوقت. عادةً ما يتم قياس 400 طيف في وقت واحد بينما الطريقة الأخرى هي القياس الطيفي واحدًا تلو الآخر.



▲ Components of Raman Microscope

Fig.2

## ما هو طيف رامان؟

يحتوي الضوء المستطار لرامان على معلومات مختلفة عن الجزيئات في المادة. إذا قمت بفصل الضوء المستطار عن طريق الطول الموجي من أجل تفسيرها، يمكنك أن ترى أن ضوء رايلي المستطار الذي يساوي الطول الموجي للضوء الساقط تم الكشف عنه بقوة ويتم اكتشاف ضوء رامان المستطار على كلا الجانبين كما هو موضح في الشكل 3. يُطلق على ضوء رامان المستطار المكتشف على جانب الطول الموجي الأقصر من ضوء رايلي المبعثر خط ستوكس المضاد، والضوء المكتشف على جانب الطول الموجي الأطول يسمى خط ذات الكثافة العالية للتحويل Stokes ستوكس. بشكل عام، يتم استخدام خطوط

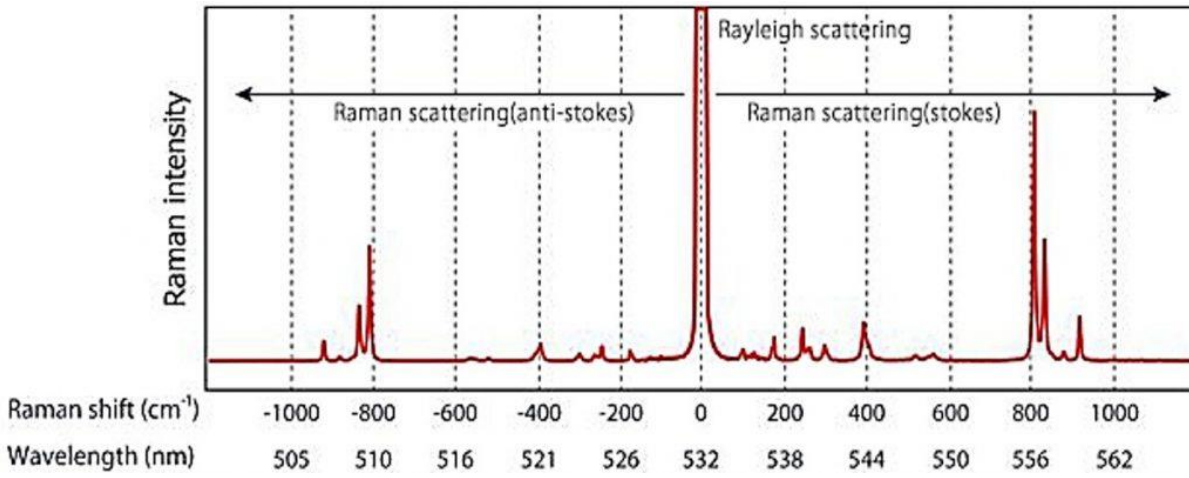

Fig.3

يتم تحويل المعلومات الخاصة بكل طول موجي مشتت إلى رقم موجي (الطول الموجي / 1) ويتم حساب الفرق مع عدد الموجة للضوء الساقط. يسمى الفرق بين الأعداد الموجية على المحور الأفقي والشدة على المحور الرأسي طيف رامان. من المحور الأفقي، يمكنك قراءة معلومات الاهتزاز الجزيئي، ومن المحور الرأسي، يمكنك قراءة قوة النشاط

حيث يمكن تحديد نوع وجودة الروابط الكيميائية. علاوة على ذلك، إذا كانت مادة بلورية، فيمكن معرفة درجة التبلور والتشوه لـ الشبكة بلورية

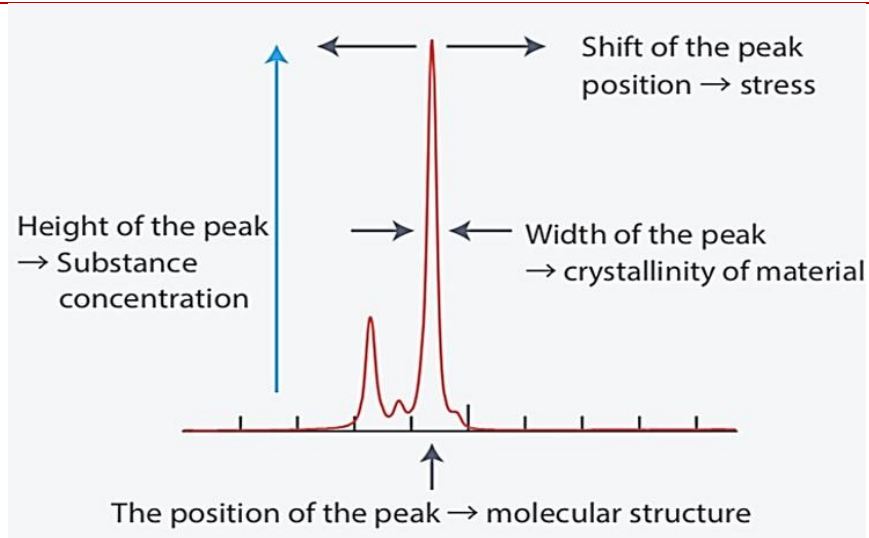

Fig.4

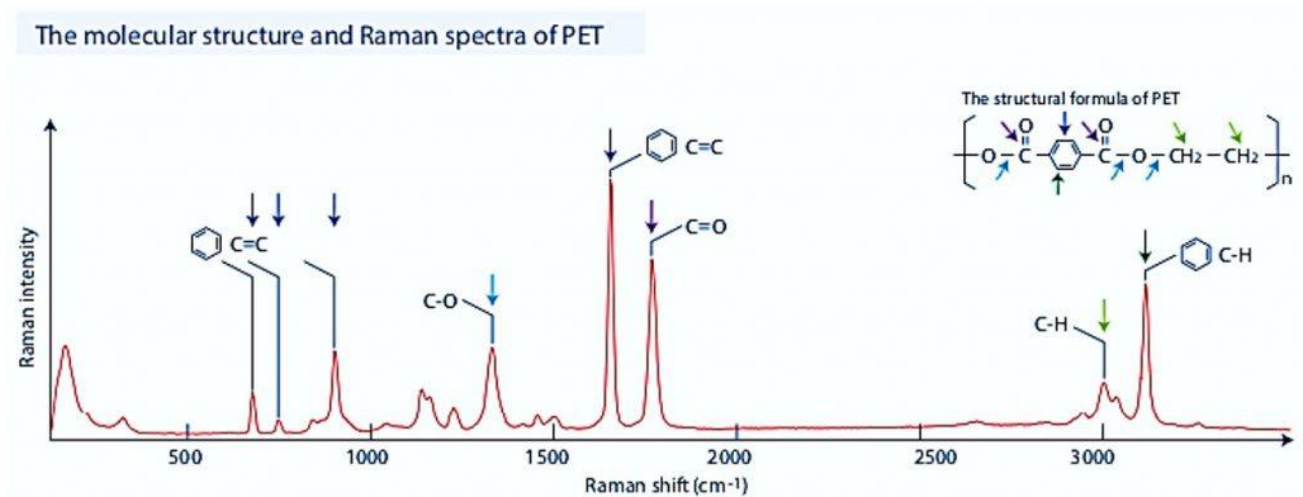

Fig.5

## Exercises

1- Find the wavelength at which the rate of spontaneous emission is equal to

the stimulated emission at a temperature under the condition of thermal equilibrium.

2 - Explain mathematically that there is no laser beam generation when the thermal energy is equal to the photon energy .

Planck's constant  $6.63 \times 10^{-34} \text{ J.s}$  and Boltzmann's constant  $1.38 \times 10^{-23} \frac{\text{J}}{\text{K}}$

3 - What is the temperature for the occurrence of the laser action and laser generation?

4- Calculate the ratio between the spontaneous emission and stimulated emission of a tungsten lamp due to a heat  $T = 1727 \text{ C}$  , where the light is visible.

## Glossary of laser definitions

### Absorption of radiation

- Receiving electromagnetic radiation by interaction with the material, and transforming it to different form, which is usually heat (rise in temperature). The a



Absorption process is dependent on the wavelength of the electromagnetic radiation and on the absorbing material.

### Active Medium

- Collection of atoms or molecules which can be stimulated to a population inversion, and emit electromagnetic radiation in a stimulated emission.

### Amplification

- The process in which the electromagnetic radiation inside the active medium within the **laser optical cavity** increase by the process of stimulated emission.

### Amplitude

- The maximum value of a wave, measured from its equilibrium.

### Anode

- The positive electrode of a gas laser, used for electrical excitation of the gas in the tube.

### Aperture

- A small opening through which the electromagnetic radiation pass.

### Argon Laser

- A gas laser in which argon ions are the active medium. This laser emits in the blue - green visible spectrum, primarily at 488 and 515 [nm].

### Attenuation

- The decrease in radiation energy (power) as a beam passes through an absorbing or scattering medium.

### Beam Diameter

- Defined as the diameter of a circular beam at a certain point where the intensity drop to a fraction of its maximum value. The common definitions are  $1/e$  (0.368) and  $1/e^2$  (0.135) of the maximum value.

### Beam Divergence

- Angle of beam spread, measured in (milli)radians. Can be approximated for small angle by the ratio of the beam diameter to the distance from the laser aperture.

### Brewster Windows

- Windows at the ends of a gas laser, used to produce polarized electromagnetic radiation. The window is at Brewster angle to the optical axis of the laser, so only one type of polarization can pass through.

### Brightness

- The visual sensation of the luminous intensity of a light source.

### Carbon Dioxide (CO<sub>2</sub>) Laser

- A gas laser in which CO<sub>2</sub> molecules are the active medium. This laser emits in the infrared spectrum, primarily at 9-11 [μm], with the strongest emission line at 10.6 [μm].

### Cathode

- The negative electrode of a gas laser, used for electrical excitation of the gas in the tube.

### Coherence

## Laser Physics

---

- A property of electromagnetic waves which are in phase in both time and space. Coherent light has [Monochromaticity](#) and low [beam divergence](#), and can be concentrated to high power densities. Coherence is needed for interference processes like [holography](#).

### Diffraction

- A wave property which create deviation from a straight line when the beam pass near an edge of an opaque object.

### Divergence

- Increase in beam diameter with distance from the aperture (see [beam divergence](#)).

### Diode Laser

#### [Semiconductor Laser](#)

### Electromagnetic Radiation (Spectrum)

- A wave which propagate in vacuum with the speed of light, and composed of simultaneous oscillations of electric field and magnetic field perpendicular to each other, and perpendicular to the direction of propagation of the beam. Created by accelerating electric charge, and include X-rays, [visible spectrum](#), [infrared spectrum](#), microwave etc.

### Electron Volt [eV]

- Unit of energy: The amount of energy that the electron accuire while accelerating through a potential difference of 1 [Volt].

$$1 \text{ [eV]} = 1.6 \cdot 10^{-19} \text{ [Joule]}$$

### Excimer Laser

- A [gas laser](#) which emits in the [UV spectrum](#). The [active medium](#) is an "Excited Dimer" which does not have a stable [ground state](#).

### Excitation

- Energizing the [active medium](#) to a state of [population inversion](#).

### Fluorescence

- Emission of light of particular [wavelength](#), as a result of [absorption of light](#) at shorter [wavelength](#). It is a property of some materials, each material has a specific [wavelength](#) of [absorption](#) and emission.

### Frequency ( $\nu$ ) (nu)

- The *number of times that the wave oscillates per second* (The number of periods of oscillations per second). For more information [click Here](#).

### Gain

- see [Amplification](#).

### Gas Laser

- A laser in which the [active medium](#) is a gas. The gas can be composed of molecules (like CO<sub>2</sub>), Atoms (like He-Ne), or ions (like Ar<sup>+</sup>).

### Ground State

- Lowest energy level of an atom or molecule.

### Helium-Neon (He-Ne) Laser

- A [gas laser](#) in which Helium (He) and Neon (Ne) atoms are the [active medium](#). This laser emits primarily in the [Visible spectrum](#), primarily at 632.8 [nm], but also have s

ome lines in the near Infrared.

### Hologram

- An interference phenomena captured on a plate (or film). It can contain enormous amount of information and a 3 dimensional image can be constructed from it.

### Injection Laser

A type of laser which produces its output from semiconductor materials such as GaAs.

### Infrared Spectrum (IR)

- Invisible electromagnetic radiation between 0.7-1,000 [ $\mu\text{m}$ ].

### Injection Laser

- See [Diode Laser](#).

### Ion Laser

- A laser in which the [active medium](#) is composed of ions of a Nobel gas (like Ar+ or Kr+). The gas is usually [excited](#) by high discharge voltage at the ends of a small bore tube.

### Irradiance (E)

- Radiant flux (radiant power) per unit area incident upon a given surface. Units: Watts per square centimeter. (Sometimes referred to as [power](#) density, although not exactly correct).

### Laser

- An acronym for [Light Amplification by Stimulated Emission of Radiation](#). A laser device is an [optical cavity](#), with mirrors at the ends, filled with material such as crystal, glass, liquid, gas or dye. A device which produces an intense beam of light with the unique properties of [coherence](#), collimation and [monochromaticity](#).

### Laser Accessories

- The hardware and options available for lasers, such as [Brewster windows](#), [Q-switches](#) and optical components used to control laser radiation.

### Laser Medium

- (See [Active Medium](#))

### Laser Rod

- A solid-state, rod-shaped [active medium](#) in which ion excitation is caused by a source of intense light ([optical pumping](#)), such as a flash lamp. Various materials are used for the rod, the earliest of which was synthetic [ruby](#) crystal (see [Solid State Laser](#)).

### Laser Pulse

- A discontinuous burst of laser radiation, as opposed to a continuous beam. A true laser pulse achieves higher peak powers than that attainable in a CW output.

### Lens

-A curved piece of optically transparent material which depending on its shape, is used to either converge or diverge light.

### Light

- Usually referred to the [visible spectrum](#). The range of [electromagnetic radiation](#) frequencies detected by the eye, or the [wavelength](#) range from about 400 to 700 [nanometers](#). The term is sometimes used loosely to include radiation beyond visible spectrum limits.

## Laser Physics

---

### Limit Accessible Emission Level (AEL)

- permitted within a particular class. In ANSI Z-136.1, AEL is determined as the product of Accessible Emission [Maximum Permissible Exposure limit \(MPE\)](#) and the area of the limiting aperture (7mm for visible and near infrared lasers).

### Limiting Aperture

- The maximum circular area over which radiance and radiant exposure can be averaged when determining safety hazards.

### Longitudinal (Axial) Modes

- Specific wavelengths in the laser output, determined by standing waves within the [laser cavity](#). Only longitudinal modes under the laser gain curve, above the laser threshold are found in the laser output.

### Maximum Permissible Exposure (MPE)

- The level of laser radiation to which person may be exposed without hazardous effect or adverse biological changes in the eye or skin.

### Metastable State

- The upper laser level. An [excited state](#) of the atom or molecule, which have a long **lifetime**.

### Micron

- Micro-meter, one millionth of a meter ( $10^{-6}$  [m]).

### Milliradian

- A unit to measure angles, one thousandth of a radian. 1 milliradian [mrad] =  $0.057^\circ$ .

### Mode locked

- A method of controlling the length of the output [laser pulse](#). Produce very short ( $10^{-12}$  [sec]) burst of pulses.

### Monochromatic Light

- Theoretically, light at one specific [wavelength](#). Practically, light with very narrow bandwidth. The light out of a laser is the most monochromatic source known to man.

### Nanometer [nm]

- one billionth of a meter ( $10^{-9}$  [m]).

### Nd:Glass Laser

- A solid-state laser in which a Nd doped glass rod is used as a laser [active medium](#), to produce 1064 [nm] [wavelength](#).

### Nd:YAG Laser

- A [solid-state laser](#) in which Neodymium doped Yttrium Aluminum Garnet is used as a laser [active medium](#), to produce 1064 [nm] wavelength.. [YAG](#) is a synthetic crystal.

### Neodymium (Nd)

- The rare earth element that is the active element in [Nd:YAG laser](#) and [Nd:Glass lasers](#).

### Optical Cavity (Resonator)

- Space between the laser mirrors where lasing action occurs.

### Optical Density

- A logarithmic expression for the [attenuation](#) produced by an attenuating medium, such as an eye protection filter.

### Optical Fiber

- A filament of quartz or other optical material, capable of transmitting light along its length by **multiple internal reflection** and emitting it at the end.

### Optical Pumping

- The excitation of the active medium in a laser by the application of light, rather than electrical discharge. Light can be from a conventional source like Xenon or Krypton lamp, or from another laser.

### Optical Radiation

- Ultraviolet, visible and infrared spectrum (0.35-1.4  $\mu\text{m}$ ) that falls in the region of transmittance of the human eye.

### Optical Resonator

- The mirrors (or reflectors) making up the laser cavity including the laser rod or tube. The mirrors reflect light back and forth to build up amplification.

### Output Coupler

- The part of the laser which enable light to come out of the laser. Usually it is a partially reflecting mirror at the end of the laser optical cavity.

### Output Power

- The energy per second (measured in Watts) emitted from the laser in the form of coherent light.

### Photon

- The elemental unit of light. Quantum of light with energy (E) proportional to the wavelength ( $\lambda$ ) (lambda) (or frequency f).

$E = hf = hc / \lambda$  (lambda). ( $\lambda$  (lambda) = wavelength,  $c$  = speed of light,  $h$  = Planks constant).

### Polarization

- Vibration of the electric field vector in specific direction perpendicular to the direction of propagation of the wave.

### Population Inversion

- An excited state of matter, in which more atoms (or molecules) are in upper state than in a lower one. This is a required situation for a laser action.

### Power

- The rate of energy delivery in a unit of time, expressed in Watts (Joules per second). Thus: 1 [Watt] = 1 [Joule]/1 [sec].

### Pulse Duration

- The "On" time of a pulsed laser.

### Pulsed Laser

- Laser which delivers energy in the form of a single or train of laser pulses.

### Pumping

- (See Optical Pumping). Addition of energy (thermal, electrical, or optical) into active laser medium. Used to produce a state of population inversion.

### Q-Switch Laser

- A laser which store energy in the active medium, to produce short pulse with high energ

## Laser Physics

---

y. It is done by blocking the resonator ability to oscillate, keeping the "Q-Factor" of the optical cavity low.

### Radian

- A unit of measurement of angles.  $2\pi$  [rad] =  $360^\circ$ ,  $1$  [rad] =  $57.3^\circ$ .

### Radiant Energy (Q)

- Energy in the form of electromagnetic waves usually expressed in units of **Joules** (watt-seconds).

### Radiant Exposure (H)

- The total energy per unit area incident upon a given surface. It is used to express exposure to pulsed laser radiation in units of  $\text{J}/\text{cm}^2$ .

### Reflection

- The return of radiant energy (incident light) by a surface, with no change in wavelength.

### Refraction

- The change of direction of propagation of any wave, such as an electromagnetic wave, when it passes from one medium to another in which the wave velocity is different. The bending of incident rays as they pass from one medium to another (e.g.: air to glass).

### Ruby Laser

- The first laser type. A solid state laser which use a crystal of sapphire (aluminum oxide) containing trace amounts of chromium oxide as an active medium.

### Scanning Laser

- A laser having a time-varying direction, origin or pattern of propagation with respect to a stationary frame of reference.

### Semiconductor Laser

- (see diode laser) A type of laser which produces its output from semiconductor materials such as GaAs.

### Solid Angle

- The ratio of the area on the surface of a sphere to the square of the radius of that sphere. It is expressed in steradians (sr).

### Solid State Laser

- A laser in which the active medium is in solid state (usually not including semiconductor lasers).

### Spontaneous Emission

- Random emission of a photon by decay of an excited state to a lower level. Determined by the lifetime of the excited state.

### Spot Size

- A measure of the diameter of the beam of laser radiation.

### Stimulated Emission

- Coherent emission of radiation, stimulated by a photon absorbed by an atom (or molecule) in its excited state.

### Transverse Mode

- The geometry of the power distribution in a cross section of a laser beam.



### **Transverse Electro-Magnetic (TEM) Mode**

- Used to designate the shape of a cross section of a laser beam.

### **TEM<sub>00</sub>**

- The lowest order [transverse mode](#) possible. The power distribution across the beam is of a gaussian shape.

### **Tunable Laser**

- A laser system that can be "tuned" to emit laser light over a continuous range of [wavelengths](#) or frequencies.

### **Tunable Dye Laser**

- A laser whose [active medium](#) is a liquid dye, pumped by another laser or flash lamps, to produce various colors of light. The color of light may be tuned by adjusting optical tuning elements and/or changing the dye used.

### **Ultraviolet (UV) Radiation**

- [Electromagnetic radiation](#) with [wavelengths](#) between soft X-rays and visible violet light, often broken down into UV-A (315-400 [nm]), UV-B (280-315 [nm]), and UV-C (100-280 [nm]).

### **Visible Spectrum (light)**

- [Electromagnetic radiation](#) which can be detected by the human eye. It is commonly used to describe [wavelengths](#) which lie in the range between 400 nm and 700-780 nm.

### **Wavelength ( $\lambda$ ) (Lamda)**

- The length of the light wave. The shortest distance at which the wave pattern fully repeats itself, usually measured from crest to crest. The wavelength of light in the visible spectrum determines its color. Common units of measurement are the [micrometer \(micron\)](#), the [nanometer](#), and (old unit) the Angstrom unit. [\[For more information click here\]](#)

### **YAG = Yttrium Aluminum Garnet**

- a widely used solid-state crystal which is composed of yttrium and aluminum oxides which is doped with a small amount of the rare-earth neodymium.
- 

## **References**

- 1- An Introduction to Laser Technology and Its Applications, SCIENCE resource Guide United States Academic Decathlon 2018®
- 2- Laser Physics & applications , Prof. Dr. Safwat William Zaki Mahmoud,  
*Dr/ hazemsakeek laser lectures*
- 3- [h](#)

## Laser Physics

---

[https://www.anits.edu.in/online\\_tutorials/ENGINEERING-PHYSICS/UNIT-IV.pdf](https://www.anits.edu.in/online_tutorials/ENGINEERING-PHYSICS/UNIT-IV.pdf)

4- <https://www.olympus-lifescience.com/en/microscope-resource/primer/java/lasers/stimulatedemission/>

5- <https://www.olympus-lifescience.com/en/microscope-resource/primer/java/lasers/heliumneonlaser/>

6- <https://www.olympus-lifescience.com/en/microscope-resource/primer/java/lasers/gainbandwidth/>

7- <https://books-library.net/free-991494181-download>

8- 8 <http://230nsc1.phy-astr.gsu.edu/hbase/optmod/lasapp.html#c1>

<https://perg.phys.ksu.edu/vqm/laserweb/Ch-1/1-6.jpg>

<https://perg.phys.ksu.edu/vqm/laserweb/Ch-1/F1s1p1.htm>

<https://www.hazemsakeek.net/raman-scattering/>

<https://physicsworld.com/a/laser-imaging-spots-brain-cancer/>

- Keresztury, Gábor (2002). “Raman Spectroscopy: Theory”. Handbook of Vibrational Spectroscopy. 1. Chichester: Wiley. [ISBN0471988472](#)
- Raman, C. V. (1928). “A new radiation”. Indian Journal of Physics. 2: 387–398. [hdl:10821/377](#)
- S. Krishnan; Raman, C. V. (1928). “The Negative Absorption of Radiation”. Nature. 122 (3062): 12–13. [Bibcode:1928Natur.122...12R](#). [doi:10.1038/122012b0](#). [ISSN 1476-4687](#). [S2CID 4071281](#)
- Singh, R. (2002). “C. V. Raman and the Discovery of the Raman Effect”. Physics in Perspective. 4 (4): 399–420. [Bibcode:....4..399S](#)

An Introduction to Lasers and Their Applications Donald C. O'Shea Addison-Wesley

Optoelectronics : An Introduction J. Wilson, J.F.B. Hawkes Englewood Cliffs ; London : Prentice-Hall

Principles of Lasers Orazio Svelto Springer Principles of Lasers, By : O.Svetto

### Basic Laser Books:

Title: "**The laser guidebook**" / **Jeff Hecht**. Publisher: New York : McGraw-Hill, 1986. Description: x, 380 p. : ill. ; 24 cm.

Title: "**Principles of lasers**" / **Orazio Svelto** ; and edited by David C. Hanna.

Publis  
her:  
New

York : Plenum, 1989. Description: 3rd ed. xiii, 494 p. : ill. ; 24 cm.

Title: "**Understanding lasers : an entry-level guide**" / Jeff Hecht.

Publisher: New York : IEEE Press, 1994. Description: 2nd ed. xx, 422 p. : ill. ; 23 cm. Series: IEEE Press understanding science & technology series

- 
- 
- 4- أساسيات الليزر عدي حمادي  
كتاب الليزر وتطبيقاته د/ سعود بن حميد اللحياني  
الليزرات: مبادئ و تطبيقات د/ محمد الصالحي - عبد الله الضويان  
1- كتاب الليزر وتطبيقاته د/ سعود بن حميد اللحياني  
2- محاضرات وكتاب أساسيات الليزر لطلاب الكليات العلمية والهندسية. اد نجم الحصري