



LINGUISTIC DRILLS

FIRST YEAR  
BASIC EDUCATION

ENGLISH DEPARTMENT

FACULTY OF EDUCATION

DR. REWAA AHMED ANWER

2022-2023

**DATA OF THE CURRICULUM:**

**FIRST YEAR**

**BASIC EDUCATION**

**ENGLISH DEPARTMENT**

**FACULTY OF EDUCATION**

**REWAA AHMED**

**150 PAGES**

**BOOST YOUR** 

# **VOCABULARY 3**

Chris Barker



**PENGUIN ENGLISH GUIDES**

# Contents

Unit	Pages	Unit	Pages
<b>Introduction</b>	<b>4 – 5</b>	<b>5 – 8 Test yourself 2</b>	<b>56 – 57</b>
<b>1 People</b>	<b>6 – 11</b>	Test exercises 1 – 6 (60 marks)	
Feelings and emotions; Character		<b>9 Describing objects: shapes and materials</b>	<b>58 – 63</b>
<b>2 The senses</b>	<b>12 – 17</b>	Two-dimensional shapes; Three-dimensional shapes; Edges, corners and points; Metals and other materials; Parts of an object; Surfaces and textures; Openings; Measuring; Describing objects	
The senses; Sight; Hearing; Touch; Smell; Taste		<b>10 In the countryside</b>	<b>64 – 69</b>
<b>3 The body and actions</b>	<b>18 – 23</b>	Features of the countryside; Parts of a plant; Parts of a tree; The earth; Describing landscape features; Groups of animals; Cereal crops; Growing and harvesting; Countryside activities	
Common verbs of movement; Speed of movement; Verbs associated with parts of the body; Verb phrases; Prepositions of motion		<b>11 In the town</b>	<b>70 – 75</b>
<b>4 Health</b>	<b>24 – 29</b>	The built environment; The town centre; Street features; Roads in and around town; Describing town and country living	
Common ailments and illnesses; Skin conditions; Common injuries; Going to the doctor; Patient; Doctor		<b>12 Holidays, celebrations and festivals</b>	<b>76 – 81</b>
<b>1 – 4 Test yourself 1</b>	<b>30 – 31</b>	Public holidays in the UK; Birthdays; Parties; Decorations; Special clothes and make-up; Christmas; Easter; Special days celebrated in the UK	
Test exercises 1 – 6 (60 marks)		<b>9 – 12 Test yourself 3</b>	<b>82 – 83</b>
<b>5 Sport</b>	<b>32 – 37</b>	Test exercises 1 – 7 (60 marks)	
Sport; Equipment; Location; Verbs / nouns; Parts of the game; Scoring		<b>Reference</b>	<b>84 – 87</b>
<b>6 Education and jobs</b>	<b>38 – 43</b>	Adjectives followed by prepositions; Transitive and intransitive verbs; Units of measurement; Dates of festivals and special days celebrated in the UK; Spelling rules; British and American English	
Teachers at school; Studying at school; Exams; Studying at college / university; Careers; Applying for a job; Requirements for a job		<b>Self assessment and progress check</b>	<b>88</b>
<b>7 Computers</b>	<b>44 – 49</b>		
Computers; Verb phrases associated with computers; The internet and e-mail; Computer knowledge			
<b>8 Music and drama</b>	<b>50 – 55</b>		
Types of performance; Places; Music (Performing; People in music; People in dance); Drama (Parts of a theatre; The stage; Plays; People; Parts of a drama; Performing); Describing a drama / a performance			



# 1 People

Translate the words and phrases.

## Feelings and emotions

### Adjectives

to feel / to be ...

- afraid (of) .....
- angry (about, with) .....
- ashamed (of) .....
- disappointed (about, in, with) .....
- disgusted (at, by, with) .....
- embarrassed (about, by) .....
- envious (of) .....
- excited (about, by, at) .....
- exhausted (by, from) .....
- frightened (of) .....
- frustrated (by, with) .....
- guilty (of, about) .....
- happy (about, for, with) .....
- hurt (by) .....
- jealous (of) .....
- proud (of) .....
- sad (about, for) .....
- shocked (at, by) .....
- sorry (about, for) .....
- surprised (at, by) .....
- tense (about) .....
- tired (of) .....
- upset (about, at, over, with) .....

### Nouns

- fear .....
- anger .....
- shame .....
- disappointment .....
- disgust .....
- embarrassment .....
- envy .....
- excitement .....
- exhaustion .....
- fright .....
- frustration .....
- guilt .....
- happiness .....
- hurt .....
- jealousy .....
- pride .....
- sadness .....
- shock .....
- sorrow .....
- surprise .....
- tension .....
- tiredness .....
- .....
- hate, hatred .....
- love .....

**REF**

See page 84 in the reference section for example sentences using the adjectives and prepositions above. See page 85 for making the comparatives of two-syllable adjectives.

to be in a good mood

to be in a bad mood

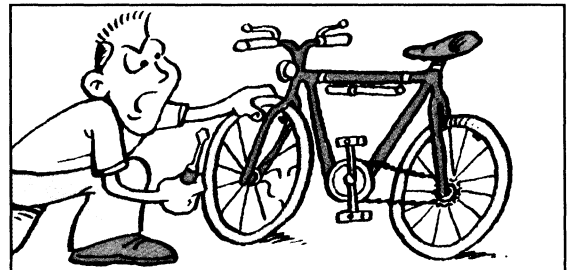
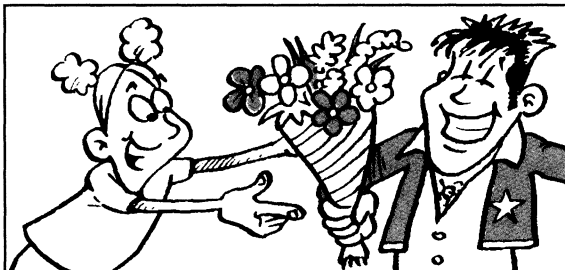

# Character

## Opposites

ambitious	.....	unambitious	.....
cautious	.....	impulsive	.....
cheerful	.....	miserable	.....
confident	.....	insecure, shy	.....
decisive	.....	indecisive	.....
easy-going	.....	difficult, fussy	.....
even-tempered	.....	bad-tempered, moody	.....
friendly	.....	unfriendly	.....
funny	.....	serious	.....
generous	.....	mean, selfish	.....
hard-working	.....	lazy	.....
honest	.....	dishonest	.....
introvert	.....	extrovert	.....
kind	.....	unkind, cruel	.....
loyal	.....	disloyal	.....
mature	.....	childish, immature	.....
modest	.....	arrogant, big-headed*	.....
nice	.....	nasty, horrible	.....
open	.....	secretive, reserved	.....
optimistic	.....	pessimistic	.....
organized	.....	disorganized	.....
patient	.....	impatient	.....
polite	.....	rude, cheeky	.....
practical	.....	impractical	.....
relaxed, laid-back*	.....	strict, uptight*	.....
reliable	.....	unreliable	.....
sensible	.....	silly	.....
sensitive	.....	insensitive, thick-skinned*	.....
sincere	.....	insincere	.....
strong	.....	weak	.....

Adjectives marked \* are used in conversational, informal language.

**REF** See page 86 for the British / American word list.



A friend is someone who | is always there for you. ....  
 | keeps promises ... and secrets. ....  
 | sticks up for you. ....

A friend is someone (whom) you can trust. ....

I can't stand | people who are (lazy). ....  
 | bullies. ....

I wish | I were (calmer / more patient). ....  
 | I wasn't so (impatient). ....

1 Match the emoticons to the meanings.  
(Turn the page 90° clockwise to see the emoticons more clearly.)

Emoticons	Meanings
1 :-○	a) exhausted
2 :-)))	b) indecisive
3 :'-(	c) really happy
4 :-\	d) upset
5 :-@	e) shocked
6  -(	f) surprised

- 1 f) surprised .....
- 2 .....
- 3 .....
- 4 .....
- 5 .....
- 6 .....



2 Find 14 adjectives to match to the statements below. Then write the opposites.

- 1 He always keeps his promises.
- 2 She can't stand waiting in bus queues.
- 3 Her room's a mess. She can never find anything.
- 4 She tells really good jokes.
- 5 He stays in bed till 12 and doesn't help in the house.
- 6 She never offers to buy a drink.
- 7 He's never happy about anything.
- 8 He thinks he knows everything.
- 9 He always thinks things are going to work out well.
- 10 He always means what he says.
- 11 He really likes her, but he doesn't tell her.
- 12 If she feels like doing something, she just does it.
- 13 He didn't apologize, he just ignored her.
- 14 That was such a stupid thing to do.

P	N	O	R	U	D	E	B	F	E
I	M	P	A	T	I	E	N	T	S
I	M	P	U	L	S	I	V	E	H
L	I	U	F	W	O	V	L	C	Y
T	M	I	S	E	R	A	B	L	E
U	A	R	R	O	G	A	N	T	S
I	R	E	L	I	A	B	L	E	I
H	U	F	U	N	N	Y	M	S	N
O	P	T	I	M	I	S	T	I	C
Y	I	O	N	E	Z	T	G	L	E
B	Y	R	L	A	E	J	W	L	R
L	A	Z	Y	N	D	R	P	Y	E

Adjective	Opposite	Adjective	Opposite
1 <u>reliable</u> .....	<u>unreliable</u> .....	8 .....	.....
2 .....	.....	9 .....	.....
3 .....	.....	10 .....	.....
4 .....	.....	11 .....	.....
5 .....	.....	12 .....	.....
6 .....	.....	13 .....	.....
7 .....	.....	14 .....	.....



**3a** Put the words in exercise 2 into groups, to help you remember them.

😊	☹️	😊 ☹️
<i>reliable</i>	<i>impatient</i>	<i>impulsive</i>



**3b** Complete these compound character-words and add them to the word groups in exercise 3a.

- 1 *bad*.....-tempered      3 .....-headed      5 .....-skinned  
 2 easy-.....      4 even-.....      6 .....-back

**4** How would you describe yourself? Use the adjectives in exercises 2 and 3, or any others that are appropriate.

Good qualities	Not-so-good qualities	Things I'd like to change
<i>I'm ...</i>	<i>But I'm sometimes ...</i>	<i>I wish I wasn't so ...</i>

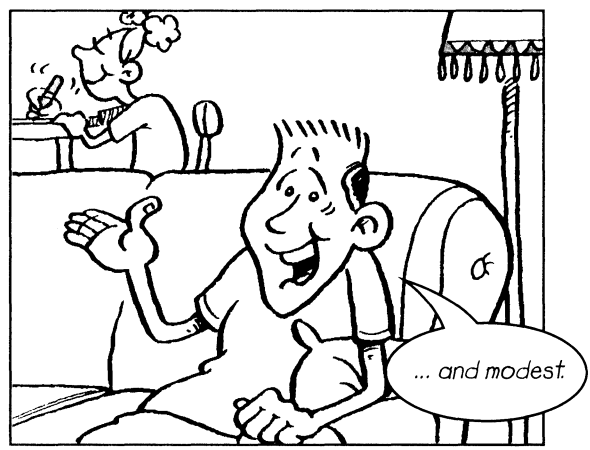

5a Complete the questions with the correct preposition. Then answer them.

### You and your emotions

- 1 When were you last angry *with* ..... someone?  
.....  
.....
- 2 Have you ever been jealous ..... anyone? Why?  
.....  
.....
- 3 What are you afraid ..... ?  
.....  
.....
- 4 What are you most proud ..... ?  
.....  
.....
- 5 What sort of things do you get excited..... ?  
.....  
.....
- 6 Have you ever been embarrassed ..... anything? Do you want to tell us about it?!  
.....  
.....

5b All the adjectives in exercise 5a have nouns associated with them. What are the nouns?

- |                      |         |         |
|----------------------|---------|---------|
| 1 <i>anger</i> ..... | 3 ..... | 5 ..... |
| 2 .....              | 4 ..... | 6 ..... |



6 Read about the qualities some British teenagers look for in a friend. Then write your own description of an ideal friend.

*A friend is someone who is kind, honest and loyal. A friend is someone who sticks up for you.*

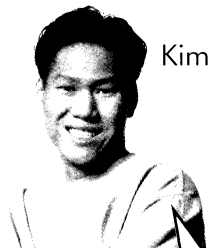
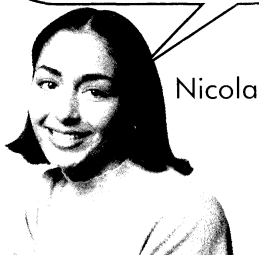

*A good friend is never jealous of you and never horrible to you. You must be able to trust one another and share things.*



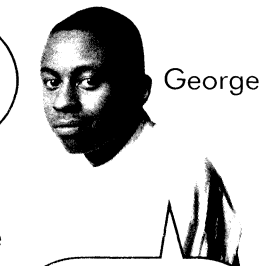

*A friend is someone you can talk to when you're upset.*



*I can't stand bullies. You can never be friends with a bully.*



7 What can you tell from a face? Read the magazine article. Then use it to write a description of your best friend. Is the description accurate?

	<b>Martin Ricca</b>	<b>Katie Holmes</b>	<b>Christina Aguilera</b>	<b>Enrique Iglesias</b>
				
Forehead	His hair falls over his forehead. This shows he's quite secretive.	She wears her hair off her forehead, so she's strong and confident.	She's got a small forehead and a parting. This signifies an open personality.	His wide forehead shows that he's strong and honest.
Eyes	He's got thick eyebrows and small eyes. This means he won't tell you much about his private life.	She's got large eyes. This shows that she's loyal and completely honest.	Her large, almond-shaped eyes show that she is friendly.	He's got deep-set eyes, so he's decisive. (If they're small, it means that the person is also cautious.)
Nose	He's got a perfect nose, which means that he's modest.	Her nose is small, which shows that she's very fussy.	Her long, straight nose shows that she is sensible and decisive.	His broad nose shows that he's strong and sporty.
Mouth	He's got thin lips. This usually shows that someone is careful and cautious.	Look at that cheeky smile! She's a very relaxed and open person.	She's got a wide mouth, which means that she's patient and hard-working.	A thin upper lip shows that someone is fussy; a thin lower lip shows that they are ambitious.



8 Write ten words and five expressions you are going to memorize.

<b>Words</b>	<b>Expressions</b>
1 .....	1 .....
2 .....	.....
3 .....	2 .....
4 .....	.....
5 .....	3 .....
6 .....	.....
7 .....	4 .....
8 .....	.....
9 .....	5 .....
10 .....	.....

# 2 The senses

Translate the words and phrases.

## The senses

sight .....  
 hearing .....  
 touch .....  
 taste .....  
 smell .....

## Sight (verbs and phrases)

see .....  
 check .....  
 notice .....  
 watch .....  
 look (I) (at) .....  
 have / take a look (I) (at) .....  
 stare (I) (at) .....  
 glance (I) (at) .....  
 gaze (I) (at) .....  
 glare (I) (at) .....  
 search (I) (for) .....  
 browse (I) (through) .....  
 examine (T) .....  
 inspect (T) .....  
 spot (T) .....

Look at that bird!  
 .....  
 Where? I can't see it.  
 .....  
 We watched the sun go down.  
 .....  
 Your new jacket looks good.  
 .....  
 You look tired.  
 .....  
 You look as if you need a rest.  
 .....

REF

Verbs marked (T) are usually transitive; verbs marked (I) are usually intransitive. All other verbs are both transitive and intransitive. For the use of transitive and intransitive verbs, see page 85.

## Hearing (verbs and phrases)

hear .....  
 sound .....  
 listen (I) (to) .....  
 overhear (T) .....

Sorry, I can't hear you.  
 .....  
 Listen to this new CD.  
 .....  
 I've never heard of the Corrs.  
 Who are they?  
 .....  
 Your cough sounds terrible.  
 .....  
 You sound as if you need a good holiday.  
 .....

## Adjectives

silent .....  
 quiet .....  
 noisy .....  
 loud .....



## Touch (verbs and phrases)

touch .....  
 feel .....  
 push .....  
 pull .....  
 drag .....  
 rub .....  
 kiss .....  
 hit .....  
 tap .....  
 itch .....  
 scratch .....

tickle .....  
 clap .....  
 pinch .....  
 punch (T) .....  
 slap (T) .....  
 smack (T) .....  
 stroke (T) .....  
 squeeze (T) .....  
 hug .....  
 shake hands .....

This jumper feels really soft. ....  
 I feel as if I could cry. ....  
 I'm tired. I feel like having an early night. ....

## Smell (verbs and phrases)

smell .....  
 sniff .....  
 stink (I) .....  
 It smells | nice. ....  
 | delicious. ....  
 | horrible. ....  
 | strange. ....  
 | revolting. ....

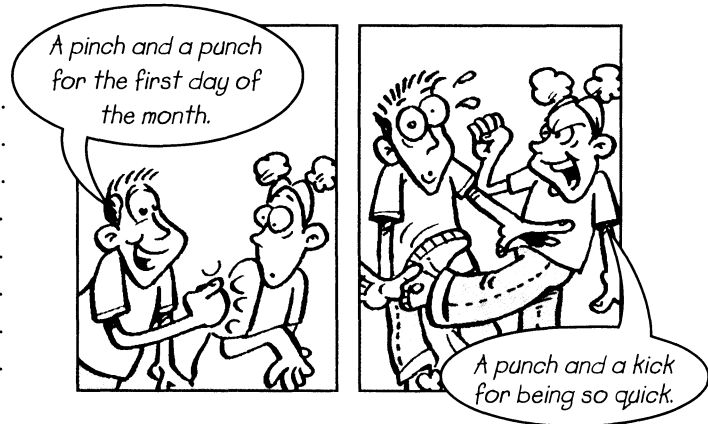

Take the rubbish bag out. It stinks! ....  
 It smells of cats in here. ....  
 What are you cooking? It smells like curry. ....  
 Get rid of that cheese. It smells horrible! ....  
 Stop sniffing and blow your nose! ....

## Taste (verbs and phrases)

taste .....  
 It tastes | bitter. ....  
 | sour. ....  
 | disgusting. ....  
 | bland. ....

It's too | sweet. ....  
 | salty. ....  
 | spicy. ....

Yuk! This ice cream tastes of garlic. ....  
 This wine tastes like vinegar. ....



**REF** See *Boost Your Vocabulary 2*, page 19, for adjectives describing food.

**REF** See page 86 for the British / American word list.



1 Which senses do you associate with these body parts?

- 1 ear *hearing* ..... 3 nose ..... 5 hand .....  
 2 eye ..... 4 tongue .....

2 Use the verbs and the adjectives to complete the captions.

<b>verbs</b>			<b>adjectives</b>			
feel	<i>smell</i>	sound	beautiful	delicious	<i>revolting</i>	soft
look (x2)	taste (x2)		disgusting	very clear	tired	



1a *It smells revolting.* 1b *But it* .....

.....  
 .....  
 .....



2a *You* ..... 2b *But you* .....

.....  
 .....  
 .....



3a *This* ..... 3b *But this* .....

.....  
 .....  
 .....

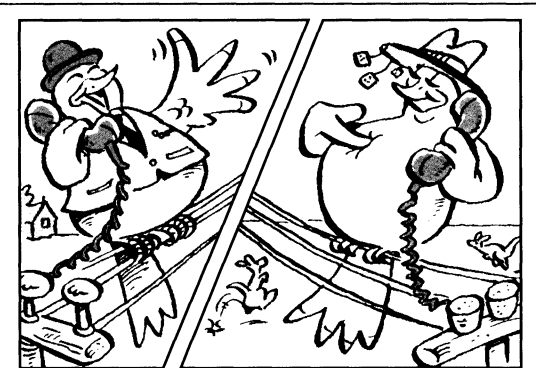

4 *You* .....

.....  
 .....



**3a** Find 20 words to do with the senses and write them in the correct group.

Q	D	Y	S	O	U	N	D	C	T
U	B	L	N	V	N	O	I	S	Y
I	N	S	P	E	C	T	Z	N	H
E	G	L	A	R	E	I	U	I	U
T	A	A	B	H	R	C	S	F	G
S	Z	P	I	E	W	E	W	F	P
T	E	S	T	A	R	E	E	M	U
I	R	S	T	R	O	K	E	S	S
N	S	M	E	L	L	I	T	C	H
K	S	C	R	A	T	C	H	W	P

**sight**

**touch**

- .....
- .....
- .....
- .....
- .....

**hearing**  
*overhear*

**taste**

- .....
- .....
- .....

**smell**

- .....
- .....
- .....

**3b** Tick the four adjectives in exercise 3a.

**3c** Use the words in exercise 3a in the sentences below. Remember to put them in the correct tense.

- 1 He knew she was angry by the way she *glared*..... at him.
- 2 I was so surprised to see him I just stood there and .....
- 3 They're obviously in love. They just ..... at each other for hours.
- 4 This is a library. Please be .....
- 5 I can't work. It's too ..... in here.
- 6 Did the customs officials ..... your luggage?
- 7 Did you ..... anything unusual in his behaviour that day?
- 8 I was in the next room, so of course I ..... what they were saying.
- 9 You can ..... the dog. He won't bite.
- 10 A: 'Don't ..... that mosquito bite. You'll make it worse.'  
B: 'But it .....!'
- 11 They were so pleased to meet again – they just ..... each other for ages.
- 12 This coffee's very ..... Put some sugar in it.
- 13 I can ..... something burning.
- 14 Your voice ..... strange. What's the matter?
- 15 How much sugar did you put in this cake? It's far too .....
- 16 The dogs ..... each other, but they didn't fight.
- 17 Ben, don't just ..... past people! Say 'Excuse me'.
- 18 He must have been very rude, because she ..... his face!
- 19 Throw that cheese away. It ..... !

#### 4 Underline the correct alternative.

- 1 I didn't read the newspaper article in detail. I just glanced / stared at it.
- 2 I like hearing / listening to the radio first thing in the morning.
- 3 She asked us to see / look at the blackboard.
- 4 I think you've got Joanne's phone number in your address book. Can I have a look / examine?
- 5 Guess who smacked / tapped me on the shoulder as I was walking to college?
- 6 Do you laugh if someone itches / tickles the sole of your foot?
- 7 If you can't carry the suitcase, just drag / rub it along the ground.
- 8 Now, children, stand in line and don't push / pull.
- 9 Simon says, 'Clap / Smack your hands.'
- 10 Can you spot / notice the difference between these two pictures?

#### 5 Complete the speech bubbles.

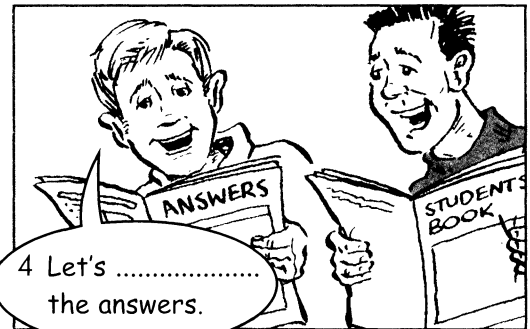
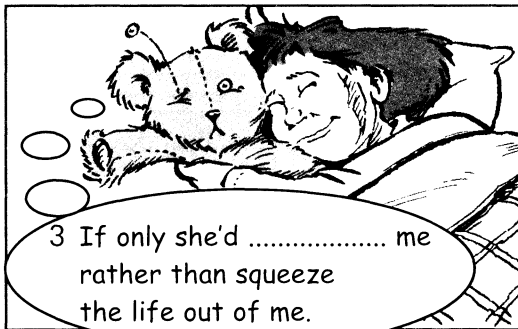
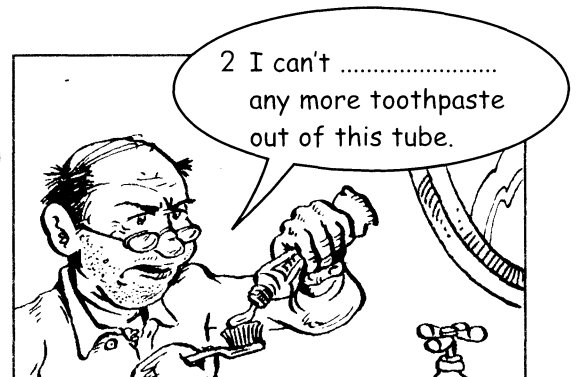

**6 What are the missing words?**

- 1 You *sound*..... as if you don't want to go to Cheryl's party.
- 2 You ..... good in bright colours.
- 3 This new shampoo makes your hair ..... as soft as silk.
- 4 Have you ..... of 'scratch cards'?
- 5 You ..... as if you've seen a ghost. What's the matter?
- 6 I ..... like going out tonight. What about you?
- 7 That after-shave lotion ..... like old socks!
- 8 I ..... as if I could run a marathon.

**7 Try this quiz. Circle A, B or C.**

What your senses say about you	5 When you meet a friend of a friend for the first time, do you
<p><b>1 Which do you prefer to touch?</b> A silk B wood C sand</p> <p><b>2 Which do you prefer to eat?</b> A sweet things B savoury things C spicy things</p> <p><b>3 Do you squeeze the tube of toothpaste</b> A from the top? B from the middle? C from the bottom?</p> <p><b>4 When you're buying a new T-shirt, do you</b> A try on lots of them? B examine lots carefully, then try one on? C have a quick look at one and take it straight to the cash desk?</p>	<p><b>A</b> shake hands? <b>B</b> kiss them? <b>C</b> just say 'hello'?</p> <p><b>6 If you have a magazine, do you</b> <b>A</b> browse through it before deciding what you want to read? <b>B</b> start at the beginning and go through to the end? <b>C</b> start at the end and work backwards?</p>
	<p><b>Analysis</b></p> <p>1A, B2, C1 You're warm and generous, but perhaps a bit emotional</p> <p>2A2, B1, C3 and impractical.</p> <p>3A3, B2, C1 9-13 points</p> <p>4A2, B1, C3 You're open, sensible and cheerful.</p> <p>5A2, B3, C1 6-8 points</p> <p>6A1, B2, C3 You're rational and practical, but perhaps too organized.</p>



**8 Write ten words and five expressions you are going to memorize.**

Words	Expressions
1 .....	1 .....
2 .....	.....
3 .....	2 .....
4 .....	.....
5 .....	3 .....
6 .....	.....
7 .....	4 .....
8 .....	.....
9 .....	5 .....
10 .....	.....

# 3 The body and actions

Translate the words and phrases.

## Common verbs of movement

- walk (I) .....
- run (I) .....
- fall (I) .....
- jog (I) .....
- hop (I) .....
- skip (I) .....
- dance (I) .....
- jump (I) .....
- slide (I) .....
- climb .....
- chase (T) .....

## Speed of movement

- rush .....
- hurry (up) .....
- slow down .....

**REF** For verbs associated with sports, see page 33. Verbs marked (T) are usually transitive; verbs marked (I) are usually intransitive. All other verbs are both transitive and intransitive. For the use of transitive and intransitive verbs, see page 85.

## Verbs associated with parts of the body

- bite .....
- blink .....
- kick .....
- knock .....
- suck .....
- swallow .....
- wave .....
- whisper .....
- whistle .....
- wink .....
- cough (I) .....
- grin (I) .....
- hiccup (I) .....
- sneeze (I) .....
- snore (I) .....
- brush (T) .....
- comb (T) .....
- lick (T) .....
- pat (T) .....

The verbs above all have an identical noun with the same meaning.

- breathe  
(noun: breath) .....
- chew .....
- point .....
- press (T) .....

## Verb phrases

- 1 stand (up) .....
- 2 sit (down) .....
- 3 lie (down) .....
- 4 shake hands .....
- 5 shake your head .....
- 6 nod your head .....
- 7 bump your head .....
- 8 bend your knees .....
- 9 fold your arms .....
- 10 cross your legs .....



- 11 bite your nails .....
- 12 bite your tongue .....
- 13 blow your nose .....
- 14 clear your throat .....
- 15 kneel down .....
- 16 bump (into something) .....
- 17 lean (on / against something) .....
- 18 trip over (something) .....
- 19 fall over (something) .....

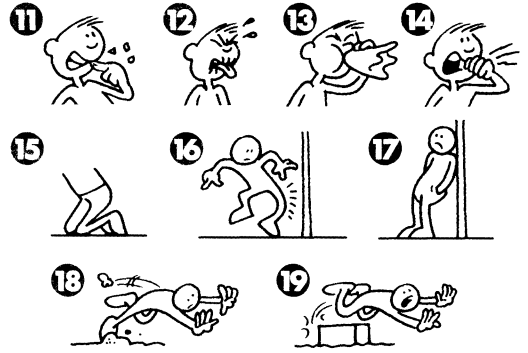

## Prepositions of motion

into

from / to

TO THE RIVER

along

down

under

over

across

through

towards

past

up

REF See page 86 for the British / American word list.



1 Write the names of a part of the body associated with each verb.

hair	eye	nose	mouth	finger	throat
	tongue	lips	teeth	hand	foot

- |           |                   |            |       |
|-----------|-------------------|------------|-------|
| 1 breathe | <i>nose</i> ..... | 11 chew    | ..... |
| 2 comb    | .....             | 12 wave    | ..... |
| 3 grin    | .....             | 13 point   | ..... |
| 4 press   | .....             | 14 bite    | ..... |
| 5 kick    | .....             | 15 blink   | ..... |
| 6 snore   | .....             | 16 whistle | ..... |
| 7 swallow | .....             | 17 wink    | ..... |
| 8 pat     | .....             | 18 whisper | ..... |
| 9 suck    | .....             | 19 sneeze  | ..... |
| 10 knock  | .....             | 20 cough   | ..... |

2a Complete these sentences by using verbs 1 to 10 in exercise 1. Put them in the correct tense.

- Chew your chewing gum, but don't *swallow*..... it.
- He ..... so loudly that I had to go and sleep in the spare room.
- We usually just ..... a ball around when we get home from school.
- Grandad always ..... me on the head, but I don't like it.
- ..... the green button to get your ticket.
- He wasn't sorry for what he's done. He just sat there and .....
- There was so much smoke, I couldn't .....
- Don't cough during the concert. .... a sweet if you have to.
- I was so late, I didn't even have time to ..... my hair.
- You should have ..... before you opened the door.

2b Complete these sentences by choosing the correct verb. Put them in the correct tense.

- blink / wink He ..... *winked* ..... at me, so I knew he was joking.
- whistle / whisper Don't tell the whole world! Just .....
- cough / sneeze 'Atchoo!' is the noise you make when you .....
- bite / chew ..... your food properly before you swallow it.
- wave / point I ..... but you didn't see me.

3 What are they doing? Write sentences using the prepositions and the verbs in the box.

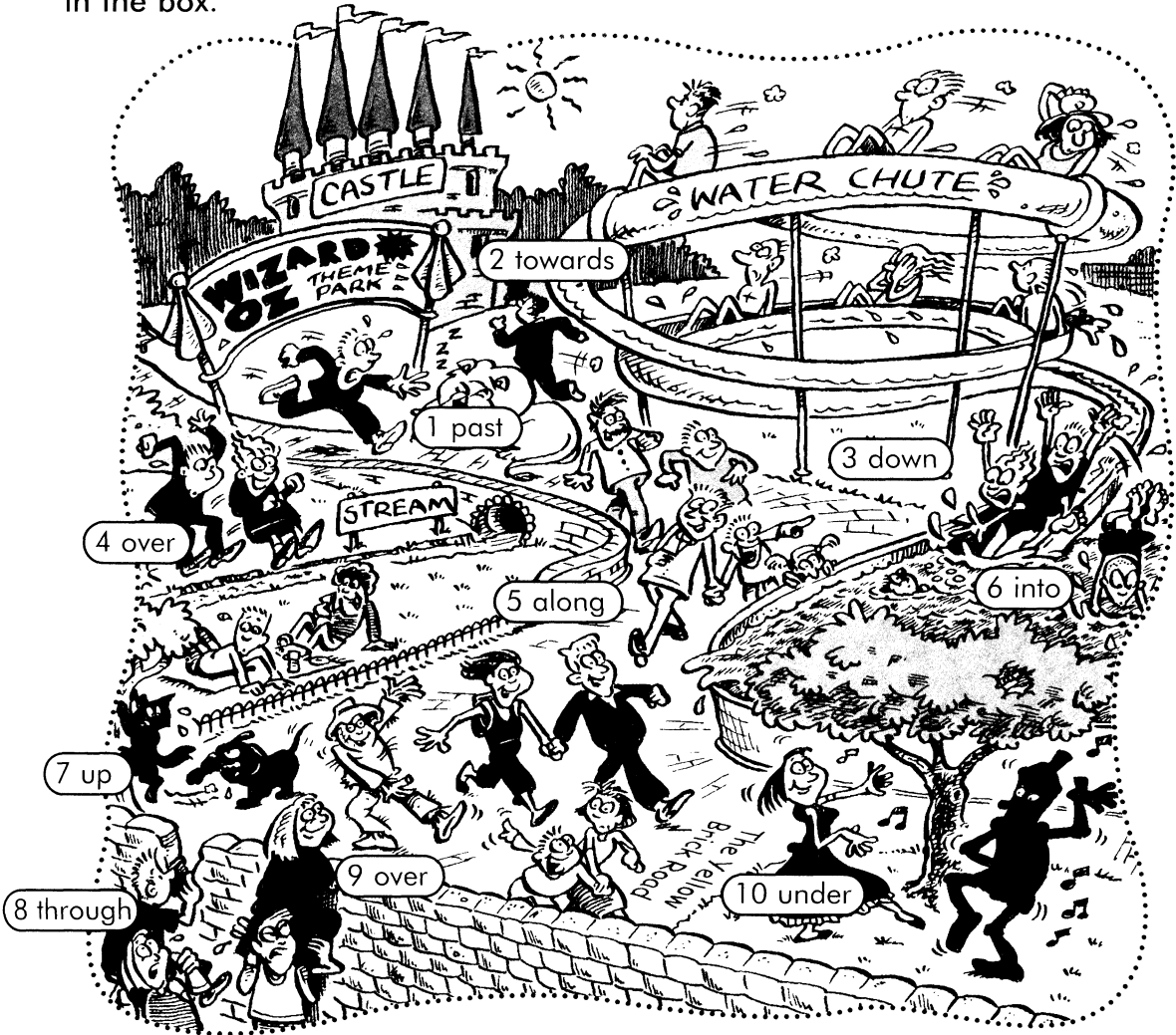

chase	dance	fall	hurry	look
jump	run	slide	climb	walk

- 1 He's *hurrying past* the lion. ....
- 2 He .....
- 3 They .....
- 4 They .....
- 5 They ..... The Yellow Brick Road.
- 6 He .....
- 7 The dog ..... the cat .....
- 8 He .....
- 9 She .....
- 10 They .....



## 4 Complete the captions and match them to the pictures.

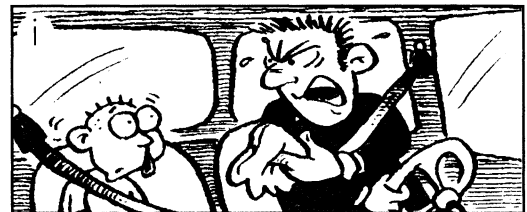
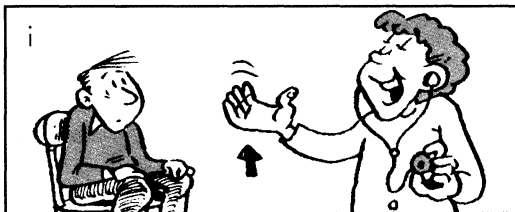
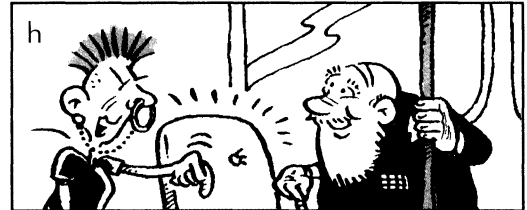
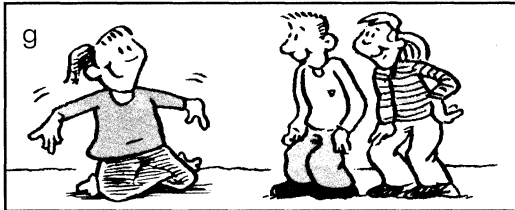
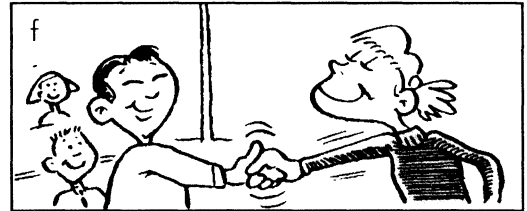
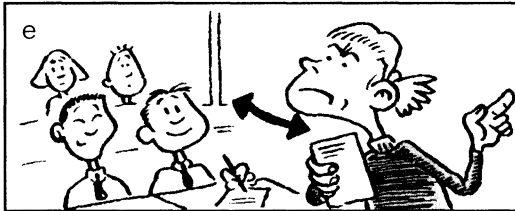
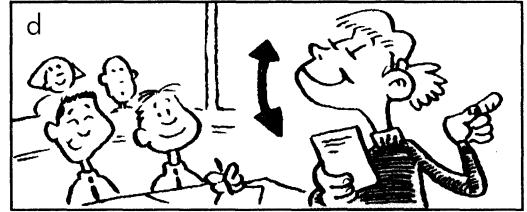
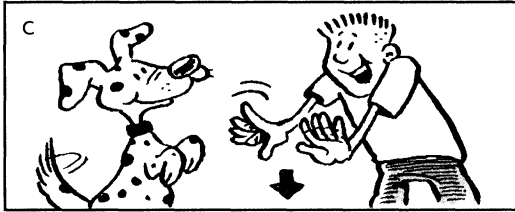
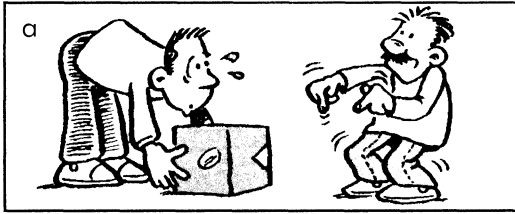

- 1 ..... *c* Lie ..... down, Spot.
- 2 ..... Stop sniffing and ..... your nose.
- 3 ..... When you meet someone for the first time, you usually ..... hands.
- 4 ..... ..... up, please.
- 5 ..... Would you like to ..... down?
- 6 ..... Don't ..... your nails!
- 7 ..... ..... your knees.
- 8 ..... ..... down on the floor.
- 9 ..... If you ..... your head, it means 'yes'.
- 10 ..... If you ..... your head, it means 'no'.

**5a** Look at the quiz. Match the idioms with their meanings.

- |           |         |         |         |          |
|-----------|---------|---------|---------|----------|
| 1 ...h... | 3 ..... | 5 ..... | 7 ..... | 9 .....  |
| 2 .....   | 4 ..... | 6 ..... | 8 ..... | 10 ..... |

**IDIOMS QUIZ**



**idioms**

- 1 You've fallen head over heels for him.
- 2 Stand your ground.
- 3 Don't bite the hand that feeds you.
- 4 Don't run before you can walk.
- 5 A nod is as good as a wink.
- 6 It's better than a kick in the teeth.
- 7 Once bitten, twice shy.
- 8 You can whistle for it.
- 9 You can kiss that goodbye.
- 10 You've bitten off more than you can chew.

**meanings**

- a You've agreed to do more than you are able to do.
- b When you have been hurt or tricked, it makes you more cautious.
- c You won't see that again.
- d You only need to give a small hint.
- e Don't be ungrateful.
- f Take your time, do things properly.
- g There's no chance of your getting what you asked for.
- h You're in love with him.
- i Don't let people try to change your mind.
- j You're not getting what you wanted, but it's better than nothing.

**5b** Which of the idioms might these people use to illustrate what they are saying?

- |   |  |
|---|--|
| 1 'You left your computer on the train? <u>You can kiss that goodbye.</u> ' ..... | 4 'You've only got three hours to do two days' work! .....                         |
| 2 'You can't stop talking about him, can you? .....                               | 5 'Well, I think you're right. Don't listen to what other people are saying. ..... |
| 3 'Look, you've won on the lottery. OK, it's only £10, but ... ..                 | 6 'I know you don't like your employer, but don't be so rude to him. .....         |



**6** Write ten words and five expressions you are going to memorize.

Words	Expressions
1 .....	1 .....
2 .....	2 .....
3 .....	3 .....
4 .....	4 .....
5 .....	5 .....
6 .....	
7 .....	
8 .....	
9 .....	
10 .....	

# 4 Health

Translate the words and phrases.

## Common ailments and illnesses

I've got ...  
a headache .....  
a sore throat .....  
a temperature .....  
a nosebleed .....  
a cold .....  
a runny nose .....  
a cough .....  
a splinter .....  
a pain in my ... .....  
a virus .....  
swollen glands .....

(a) migraine .....  
(a) stomach ache .....

toothache .....  
backache .....  
earache .....

flu .....  
food poisoning .....  
indigestion .....  
cramp .....  
diarrhoea .....  
hay fever .....

I'm ... .....  
allergic (to) .....  
constipated .....  
sunburnt .....

I feel ... .....  
well .....  
ill .....  
sick .....  
dizzy .....  
faint .....  
depressed .....

## Skin conditions

I've got ...  
a rash .....  
a bruise .....  
a blister .....  
a wart .....  
a lump .....  
a scar .....  
a spot .....  
a cold sore .....  
a mouth ulcer .....

## Common injuries

be stung (by a wasp) .....  
be bitten (by a dog) .....  
be injured (in an accident) .....  
twist (your ankle) .....  
sprain (your wrist) .....  
break (your arm) .....  
burn yourself .....  
scald yourself .....  
cut (your finger) .....  
graze (your knee) .....



## Going to the doctor

go to your doctor

.....

see a specialist

.....

have an injection

.....

have symptoms

.....

have an X-ray

.....

have a blood test

.....

get a prescription (for)

.....

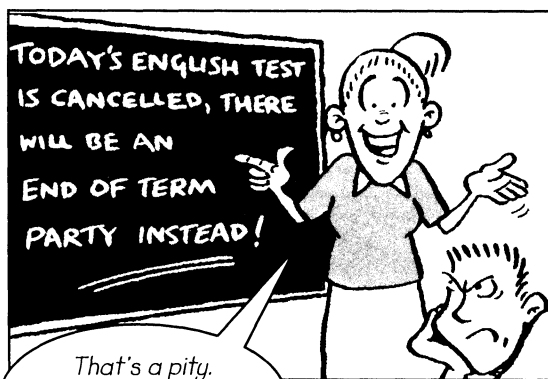
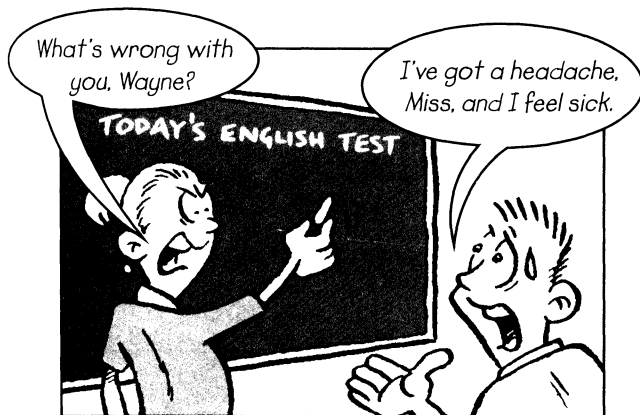

REF

See page 86 for the British / American word list.

## Patient

Can I have an appointment to see the doctor, please?

.....

It isn't urgent.

.....

I've got pains in my chest.

.....

I ache all over.

.....

I keep being sick.

.....

My foot hurts.

.....

I've hurt my arm.

.....

My ankle's swollen up.

.....

How long will it take to heal?

.....

I've lost my appetite.

.....

## Doctor

I'll need to examine you.

.....

Is it painful?

.....

You may have broken a bone.

.....

Take this medicine.

.....

Take one tablet three times a day.

.....

Put a plaster / bandage on it.

.....

Put some ointment / cream on it.

.....

It's a deep cut. You'll need stitches.

.....



1 Complete the words.

# Common illnesses

## F Flu

▶ What are the symptoms of flu?

You feel *d e p r e s s e d*.

You have a t \_ \_ \_ \_ \_ .

You a \_ \_ \_ all over.

You may have a r \_ \_ \_ \_ n \_ \_ \_ .

You may also have a s \_ \_ \_ \_ t \_ \_ \_ \_ .



## Food poisoning

▶ What are the symptoms of food poisoning?

You have s \_ \_ \_ \_ \_ a \_ \_ \_ \_ .

You feel s \_ \_ \_ .

You may have *d i a r r h o e a*.

You may also have a h \_ \_ \_ \_ \_ .

2 Describe what's wrong with Wayne.

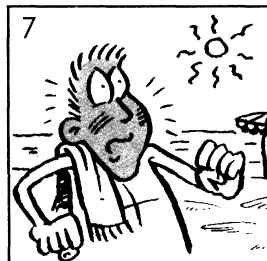
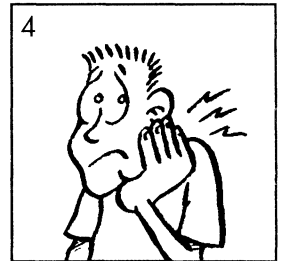
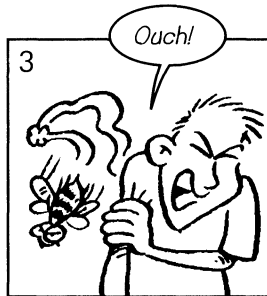

- 1 *He's got earache.*.....
- 2 .....
- 3 .....
- 4 .....

- 5 .....
- 6 .....
- 7 .....
- 8 .....

**3a Complete the conversation.**

(Wayne's got a cough. He phones the doctor's surgery to ask for an appointment.)

Receptionist: Hello, surgery.

Wayne: Hello. *Can I* .....

Receptionist: Yes, of course. When would you like to come in?

(He'd like to see the doctor today.)

Wayne: .....

Receptionist: Is it urgent?

(Give your opinion!)

Wayne: .....

Receptionist: Would Friday afternoon be OK?

Wayne: Yes, that's fine.



**3b Answer the questions.**

What did the doctor say to Wayne? Choose from column A.

What did the doctor say next? Choose from column B. ....

A	B
1 You've only grazed your knee.	a Do you sleep well?
2 It's a deep cut.	b I need to examine your chest.
3 I'll give you a prescription for some tablets.	c I'll send you for an X-ray.
4 Your foot is very swollen. You may have broken a bone.	d Take one three times a day.
5 So you're going to travel around the world?	e I'll send you to see a specialist.
6 Depression can be linked to tiredness.	f You may need some injections.
7 I don't know what's causing the rash.	g The nurse will clean it and put some antiseptic cream on it.
8 Take your shirt off, please.	h You'll need stitches.

**3c For statements 1 to 7 in column A, choose a statement from column B to show what the doctor said next.**

1 *g*..... 2 ..... 3 ..... 4 ..... 5 ..... 6 ..... 7 .....

**4 Identify these skin conditions. The words are all in the wordsearch.**

B	L	I	S	T	E	R
R	U	L	C	E	R	S
U	M	W	A	R	T	O
I	P	S	R	A	S	H
S	P	O	T	D	C	K
E	S	O	R	E	L	I



1 *lump*..... 6 s.....  
 2 *b*..... 7 b.....  
 3 *s*..... 8 r.....  
 4 *cold*..... 9 w.....  
 5 *mouth*.....

5 Follow the instructions. Then answer the questions.

*We'd like you to take part in our health survey. Please answer the questions in our 'Check up' and send it to us. We'll publish the results in next month's issue.*

**Remember:**  
**stay healthy, be happy!**

## Check-up

**1** Which of the following have you had in the past six months?

- |                      |                      |
|----------------------|----------------------|
| ..... backache       | ..... headache       |
| <i>a</i> ..... cold  | ..... indigestion    |
| ..... cough          | ..... nosebleed      |
| ..... cramp          | ..... sore throat    |
| ..... diarrhoea      | ..... stomach ache   |
| ..... earache        | ..... swollen glands |
| ..... flu            | ..... temperature    |
| ..... food poisoning | ..... toothache      |

Write in  
a or an  
where  
necessary.

**2a** In the last month, have you felt

s i c k ?

d \_ \_ \_ \_ ?

f \_ \_ \_ \_ ?

Yes    No



**2b** Are you a l \_ \_ \_ \_ \_ c to anything?

If so, give details. ....

Do you get h \_ \_ f \_ \_ \_ \_ , m \_ g r \_ \_ \_ e or any other  
condition? If so, give details. ....

.....





Unjumble the verbs in brackets.

**3** Have you ever (tifaned) fainted .....? Yes No  
 (raspined) ..... your wrist?  
 (stwitied) ..... your ankle?  
 (korben) ..... a bone?  
 (nurbt) ..... yourself?  
 (dalsced) ..... yourself?  
 Give details. ....

Complete the questions.

**4** Have you ever had ..... food poisoning?  
 ..... your appetite?  
 ..... depressed?  
 ..... by a dog or other animal?  
 ..... an X-ray?  
 ..... by a bee or other insect?  
 Give details. ....

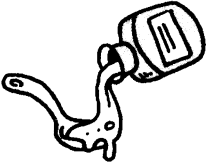
Write in the words.

**5** Which of these have you taken or used in the last month?  
 Yes No  
 Yes No  
 Yes No



**6** Write ten words and five expressions you are going to memorize.

Words	Expressions
1 .....	1 .....
2 .....	2 .....
3 .....	3 .....
4 .....	4 .....
5 .....	5 .....
6 .....	6 .....
7 .....	7 .....
8 .....	8 .....
9 .....	9 .....
10 .....	10 .....



# Test yourself 1 (Units 1 to 4)

How much can you remember?

My mark: 60

**1a** Complete the sentences using adjectives derived from the nouns in the box.

guilt	surprise	fear	disappointment	jealousy	anger
-------	----------	------	----------------	----------	-------

- 0 I didn't expect Emma to come to the party. I'm really *surprised*.....
- 1 You're not ..... of your best friend, are you? You can't be serious!
- 2 You're so bad-tempered at times. Why do you get so ..... about little things?
- 3 Jordan's exam results weren't very good. He's very .....
- 4 She did nothing wrong, so she doesn't feel .....
- 5 Were you ..... of the dark when you were a child?

(5 marks)

**1b** Use six more adjectives to describe Eddie's character.



I'll say and do things that other people are afraid to say and do. I'm not at all shy. I sometimes get into trouble because I act too quickly.

I'll help anyone who needs help. I always stick up for my friends. If I say I'll do something, I'll do it.

Eddie's *extrovert*....., ....., and ..... He's also ....., ..... and .....

(5 marks)

**2** Replace the words in *italics* with a single verb.

- 0 They *looked into* each other's eyes for a long time. *gazed*.....
- 1 She *looked out of* the window for a long time. ....
- 2 I *looked at* the newspaper very quickly. ....
- 3 The doctor *looked at* the patient *carefully*. ....
- 4 They *looked angrily* at each other. ....
- 5 Let's see if we got the answers *right*. ....
- 6 I *suddenly saw* an eagle in the distance. ....
- 7 I *looked carefully* for my keys. ....
- 8 I took my time to read through the magazine. ....

(8 marks)

**3 Match the two halves of the sentences.**

0 This milk tastes	6 Touch	a upset.	f the button.
1 Clap	7 My skin feels	b your hands.	g soft.
2 Push	8 That cheese	c the cat.	h like old socks.
3 You can stroke	smells	d your jacket	i like having a party.
4 Hit	9 Don't drag	along the ground.	j the ball.
5 You sound	10 I feel	e your toes.	k sour.

0 *k*...      2 .....      4 .....      6 .....      8 .....      10 .....

1 .....      3 .....      5 .....      7 .....      9 .....

**4 Complete the words.**

(10 marks)

Action	Part of the body	Ailments / Illnesses
n <i>od</i> .....	head	I've got a h <i>eadache</i> .....
b .....	teeth	I've got t.....
sw .....	throat	I've got a s.....throat.
k .....	foot	My ankle's sw .....
w .....	hand	I've sp ..... my wrist.
b .....	knee	I've gr ..... my knee.

(10 marks)

**5 Make commands by matching a word / phrase from column A with a word / phrase from column B.**

0 Sit	7 Kneel	a up (x2)	g your nose	0 <i>b</i>	7 .....
1 Hurry	8 Lie	b down (x4)	h your throat	1 .....	8 .....
2 Slow	9 Shake	c hands	i on the gate	2 .....	9 .....
3 Stand	10 Cross	d your legs		3 .....	10 .....
4 Fold	11 Don't lean	e your arms		4 .....	11 .....
5 Blow	12 Don't bite	f your nails		5 .....	12 .....
6 Clear				6 .....	

(12 marks)

**6 What's the problem?**

0 I've eaten too much and I've got a stomach ache.	He's got <i>indigestion</i> .
1 I ate some strawberries, and now I've got a rash.	She's ..... to strawberries
2 I didn't realize the oven was hot when I touched the shelf.	He ..... himself.
3 I've been out in the sun all day and my skin's very red.	She's .....
4 I've spilt very hot water on my foot.	He's ..... himself.
5 I feel unhappy all the time and I don't know why.	She's .....
6 Ouch! That knife's sharp!	He's ..... his finger.
7 I was sliding on the ice and I tripped over.	She's ..... her ankle.
8 I've been very sick. I ate some fish that wasn't fresh.	He's got food .....
9 I haven't eaten much for a couple of days.	She's lost her .....
10 I can't keep my balance.	He feels .....

(10 marks)

# 5 Sport

Translate the words and phrases.

Sport	Equipment	Location
archery .....	bow .....	field .....
	arrow .....	
badminton .....	racket .....	court .....
	shuttlecock .....	
baseball .....	bat .....	pitch .....
	ball .....	
basketball .....	ball .....	court .....
boxing .....	gloves .....	ring .....
canoeing .....	canoe .....	
	paddle .....	
fishing .....	rod .....	
	line .....	
football .....	(foot)ball .....	pitch .....
golf .....	ball .....	course .....
	clubs .....	
field hockey .....	stick .....	pitch .....
	ball .....	
ice hockey .....	stick .....	rink .....
	puck .....	
ice skating .....	skates .....	rink .....
(motor) racing .....	racing car .....	circuit .....
riding .....	saddle .....	
	bridle .....	
running .....		track .....
skiing .....	skis .....	run .....
	sticks .....	piste .....
surfing .....	surfboard .....	
swimming .....	goggles .....	pool .....
tennis: .....	racket .....	court .....
singles .....	ball .....	
doubles .....		
scuba diving .....	mask .....	
	air cylinder .....	
volleyball .....	ball .....	pitch .....
windsurfing .....	windsurfer .....	
weightlifting .....	weights .....	

We took part in (a game, a match).

.....

We won. / We drew. / We lost.

.....

We beat our opponents 2-1.

.....

We were in the lead at half time.

.....









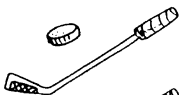

	Verbs / nouns	Parts of the game	Scoring
<b>KICKS</b>	kick .....	first half	goals
	pass .....	.....	.....
	dribble .....	half time	1-0 (one - nil)
	tackle .....	.....	.....
	intercept* <sup>1</sup> .....	second half	1-1 (a draw, one all)
	foul .....	.....	.....
	shoot* <sup>2</sup> .....	<div style="border: 1px solid black; padding: 5px;"> <p>*1 noun: interception            *2 noun: shot            *3 noun: header</p> </div>	
	miss .....		
	score .....		
	head (T)* <sup>3</sup> .....		
save (a goal) (T) .....			
be sent off .....			
be shown a yellow / red card .....			
<b>BALLS</b>	shoot* <sup>4</sup> .....	halves (amateur)	baskets
	throw .....	.....	.....
	bounce (I,T* <sup>5</sup> ) .....	quarters (professional)	.....
	<div style="border: 1px solid black; padding: 5px;"> <p>*<sup>4</sup>noun: shot. *<sup>5</sup>The ball bounced. (I)            He bounced the ball. (T)</p> </div>	.....	
<b>IS</b>	serve* <sup>6</sup> .....	game	15-0 ('fifteen-love')
	return .....	.....	.....
	volley .....	set	15-15 ('fifteen all')
	smash .....	.....	.....
	lob .....	match	40-40 ('deuce')
	.....	40-40A ('advantage')	
	<div style="border: 1px solid black; padding: 5px;"> <p>*<sup>6</sup>noun: serve / service. Other useful nouns are forehand and backhand.</p> </div>	.....	game
	.....	.....	.....
<b>BALLS</b>	hit .....	nine innings	runs
	strike .....	.....	.....
	pitch .....	<div style="border: 1px solid black; padding: 5px;"> <p><b>REF</b> See also Unit 8, Sports, in Boost Your Vocabulary 1.</p> </div>	<div style="border: 1px solid black; padding: 5px;"> <p><b>REF</b> See page 86 for the British / American word list.</p> </div>
	catch (T) .....		

**REF** All the verbs in the left hand column have identical nouns apart from those marked \* - see red boxes.  
 Verbs marked (T) are usually transitive; verbs marked (I) are usually intransitive. All other verbs are both transitive and intransitive. For the use of transitive and intransitive verbs, see page 85.

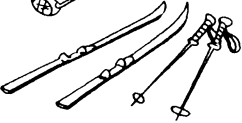
 1a Label the equipment.

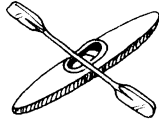
1b For each item or pair of items write in the name of the sport.

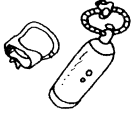
1c For 1 to 7, write the name of the location where the sport takes place.

	a) Equipment	b) Sport	c) Location
1	 racket, ball	.....	.....
2		.....	.....
3		.....	.....
4		.....	.....
5		.....	.....
6		.....	.....
7		.....	.....
8		.....	.....
9		.....	.....
10		.....	.....
11		.....	.....
12		.....	.....



**2a** Complete the words. Then guess the sport.

There are nine n n i n g s in a game. Teams take it in turns to bat. There are nine players in each team. The pitcher t h \_ \_ \_ \_ the ball to the batter.

To s c \_ \_ \_ a run, the batter must run round the bases to reach home. If the batter h \_ \_ \_ the ball and a 'fielder' (that is, a player from the opposing team) c \_ \_ \_ \_ \_ the ball, he is out. A runner is also out if h

Sport .....

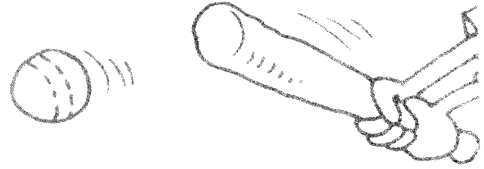

Each team has ten players, but only five can be on c \_ \_ \_ \_ at one time. Players try to score p \_ \_ \_ \_ \_ by throwing the ball into the opposition's b \_ \_ \_ \_ \_ . Players move the ball around by p \_ \_ \_ i n g, d r \_ \_ \_ \_ i n g, and s h \_ \_ \_ i n g, using only their hands to play the ball. They can t h \_ \_ \_ it, b \_ \_ \_ \_ \_ it or roll it, but they can't punch it. Running while holding the

Sport .....

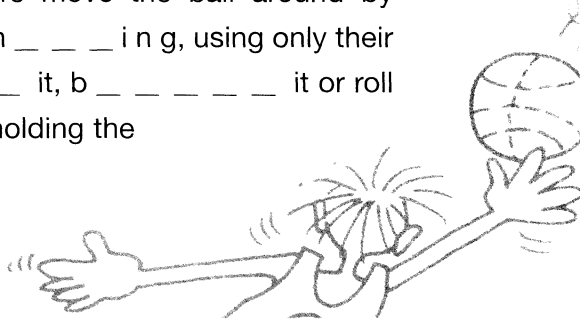

A game of one player against another player is called singles; a game of two against two is called d \_ \_ \_ \_ \_ . At the start of each point, a player s \_ \_ \_ \_ \_ the ball to his / her opponent. Players hit the ball over the net until one of them m \_ \_ \_ \_ \_ it or does not r \_ \_ \_ \_ \_ it over the net. You can hit the ball after it has b \_ \_ \_ \_ \_ , or you can v \_ \_ \_ \_ \_ it. A match is divided into three or five s \_ \_ \_ \_ .

Sport .....



**2b** Explain how your favourite sport is played.

3 Complete the report of a football match at Wayne and Tracy's school and number the pictures in the correct order.

Back Forward Stop Refresh Home Smaller Print Mail Preferences

Favorites

**Inter-house football match**

**Beaumont House 2**

**De Montfort House 0**

The star of last Friday's football match was undoubtedly Tracy Bradshaw, especially in the closing minutes of the match. The excitement really started when Jordan Peters <sup>1</sup> *passed*..... the ball to Tracy. Tracy <sup>2</sup>..... the ball past three players, but was stopped by a magnificent <sup>3</sup>..... from Amy Macpherson. Amy kicked the ball high but Jordan intercepted it and again <sup>4</sup>..... it to Tracy. Tracy had a <sup>5</sup>..... at goal, but goalkeeper Wayne Connolly managed to <sup>6</sup>..... it. A couple of minutes later, when a high ball came Tracy's way, she jumped, <sup>7</sup>..... it into the net and <sup>8</sup>..... her second goal of the match. A minute before the end of the match, she was about to score again when she was <sup>9</sup>..... by Wayne, who was immediately <sup>10</sup>..... by the referee.

Beaumont <sup>11</sup>.....  
De Montfort 2-0.

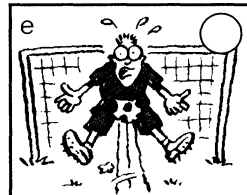

f  Beaumont 2  
 De Montfort 0



4 Continue this commentary using the verbs in the box in order.

kick dribble tackle pass intercept head shoot save 1 "Fowler kicks the ball high to Owen..."

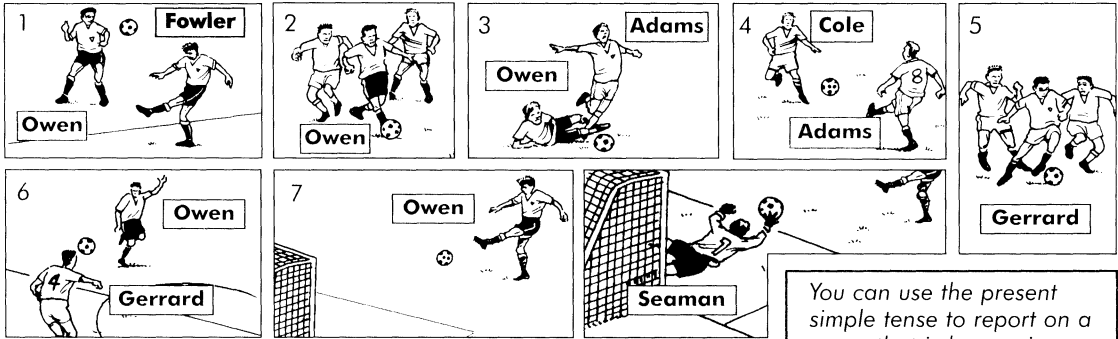

You can use the present simple tense to report on a game that is happening as you speak.

5 Try this sports quiz.

Which sports do you associate with these words?

shuttlecock .....

puck .....

smash ..... (3 points)

Which sports take place in a

court? .....

rink? .....

ring? ..... (6 points)

In tennis

how do you say '15-0'? .....

how do you say '40-40'? .....

what is the point after

40-40 called? ..... (3 points)

Check your answers on page D of the Answer key.

**Analysis**

9-12 points: You're good at sport, aren't you?

5-8 points: You like sport, but it isn't your whole life.

1-4 points: Do you know where the local sports centre is?

6 Write ten words and five expressions you are going to memorize.

Words	Expressions
1 .....	1 .....
2 .....	2 .....
3 .....	3 .....
4 .....	4 .....
5 .....	5 .....
6 .....	6 .....
7 .....	7 .....
8 .....	8 .....
9 .....	9 .....
10 .....	10 .....



# 6 Education and jobs

Translate the words and phrases.

## Teachers at school

teacher .....

staff (U) .....

member of staff .....

*U = a noun which is uncountable in this context*

head of department .....

deputy head .....

headteacher .....

## Studying at school

lesson .....

class .....

marks .....

assignment .....

coursework (U) .....

continuous  
assessment (U) .....

homework (U) .....

revision (U) .....

I do my homework between 6p.m. and 8p.m.  
.....

I'm revising for my exams at the moment.  
.....

My father left school at 16.  
.....

**REF**

See also Unit 7 in **Boost Your Vocabulary 1**.

## Exams

exam .....

test .....

mark (e.g. 17 / 20) .....

grade (e.g. B+) .....

I took / sat / did an exam.  
.....

I passed.  
.....

I failed.  
.....

I did well (in History).  
.....

I did badly in (Maths).  
.....

I retook Maths.  
.....

## Studying at college / university

go to university / college  
.....

get a place at (Oxford)  
.....

read (= study) (Geography)  
.....

go to lectures / seminars / tutorials  
.....

get a degree  
.....

do a course in (hotel management)  
.....

do (Music)  
.....

undergraduate  
.....

graduate  
.....

postgraduate  
.....

do research  
.....

## Careers

I'd like to work in ...

- information .....
- technology .....
- banking .....
- marketing .....
- the film industry .....
- the fashion industry .....
- the leisure industry .....
- the media .....

I'd like to ...

- set up my own business .....
- open a shop .....

## Applying for a job

- application form .....
- CV (curriculum vitae) .....
- references .....
- experience (U) .....
- qualifications .....
- interests .....

## Requirements for a job

You need to have qualifications in (Maths and English).

.....

You need to be good at (English).

.....

You need to be good with people.

.....

I'd like to be ...

- an architect .....
- a doctor .....
- a vet .....
- a journalist .....
- a policeman / policewoman .....
- a firefighter .....
- a lawyer .....
- a nurse .....
- a DJ .....



Students at British state schools do work experience for one or two weeks when they are in Year 10 or Year 11 (aged 14–16).

**REF** See Unit 1 for words to describe character.

**REF** See page 86 for the British / American word list.



1 Complete the questions using the words in the box. Then answer them.

assessment	class	course	coursework	department	grade
	homework	lessons	marks	revising	staff

- 1 How many students are there in your *class*.....?
- 2 How many members of ..... are there at your school?
- 3 What is the name of the head of the English .....?
- 4 How many ..... do you have each day?
- 5a How many ..... did you get in your last English test?
- OR
- 5b What was your ..... in your last English test?
- 6 How long does it take you to do your ..... each night?
- 7 Which do you prefer: exams, continuous ....., or a mixture of the two?
- 8 Do you like to have music in the background when you are ..... for an exam?
- 9 Which are you better at: exams or .....?
- 10 When you leave school, what would you like to do a ..... in?

2a Are exams fair or not? Tick the statements you agree with.

## Are exams fair?

### YES

- The alternative to sit-down exams is to do coursework over the whole school year. This gives students the opportunity to cheat. They can copy other people's work, for example.
- Continuous assessment isn't fair. Children who have their own room to study in and access to books and computers at home have a much better chance of success than children who don't have those things.

### NO

- You might have hay fever or feel sick on the day of an exam, and so you do badly. That's unfair.
- Exams are a test of memory. They don't test how much you really know.

2b Write your own reason for being in favour of or against exams.

.....  
 .....

3a Read about Yasmin's education and plans. Complete the chart.

 <p><i>There are so many exams at English schools! I had to do SATs in English, Maths and Science when I was 7, 11 and 14. I did ten GCSEs last year. I passed nine of them with quite good grades, but I failed Physics. I hated Physics. I didn't retake it; I was really glad to give it up! I'm 17 now and I've just done my AS levels in English, French, History, Music, and Art. I'm waiting for my results. I hope I've done well. Then I want to do A levels in English, French and History. I'd like to be a lawyer, so I'm hoping to get a place at university to read Law. And to take more exams. Lovely!</i></p>	Age	Exams
	7, ....., .....	SATs in ....., .....
	16  .....	..... : Passed ..... Failed .....  ..... : English, French, History, Art, Music
	Plans	..... : English, French, History University course: .....

**What the letters stand for**

- SATs – Standard Assessment Tasks: pronounced 'sats'
- GCSE – General Certificate of Secondary Education: letters pronounced separately
- AS – Advanced Subsidiary: letters pronounced separately
- A – Advanced

3b Write an account of your education and plans, similar to Yasmin's.

4 Fill in the careers advice form.

**Careers Advisory Service**

- 1 What are your career plans? What sort of job interests you?  
*I'd like to* .....
- 2 What interests do you have which make you suitable for this kind of work?  
.....  
.....
- 3 What experience do you have which makes you suitable for this kind of work?  
.....  
.....
- 4 Do you want to go to college or university when you leave school? What do you want to study?  
.....  
.....

- 5 The questions are missing from this interview with a disc jockey. Write the number of each paragraph next to the correct question.



## So you want to be a...

- 1 Age isn't really important, but most DJs are at least 16.
- 2 Anyone with the right attitude can be a DJ, but knowledge of all types of music and mixing is essential. You need to be up-to-date with the latest music trends.
- 3 DJing at a nightclub or on an evening radio show will mean late nights. Presenting a breakfast show could mean getting up at 4.30 a.m.
- 4 Getting free records, meeting famous people and becoming famous yourself.
- 5 Having to play records you hate, having to be cheerful when you're not feeling well and working long hours.
- 6 It's badly paid to start with, but you can earn loads of money if you're good.
- 7 Start off with work experience at your local radio station or hospital radio. Learn how to mix by going on a DJ course. Keep an eye on the charts.
- 8 You must love music and be outgoing, funny and organized. You have to interview lots of people, so it's no use being shy.

### headings

### paragraph

- What qualifications do you need?  
 How old do you need to be?  
 What sort of a person do you need to be?  
 What about training?  
 What are the hours?  
 What's the money like?  
 What's the best bit about the job?  
 What's the worst bit?

- 2.....  
 .....  
 .....  
 .....  
 .....  
 .....  
 .....  
 .....

6 Imagine you have worked in your chosen job for a year. You're talking to some students who are thinking of doing the same job as you. Answer their questions.

See exercise 4 question 1. If you chose to be a disc jockey, choose something else for this exercise!

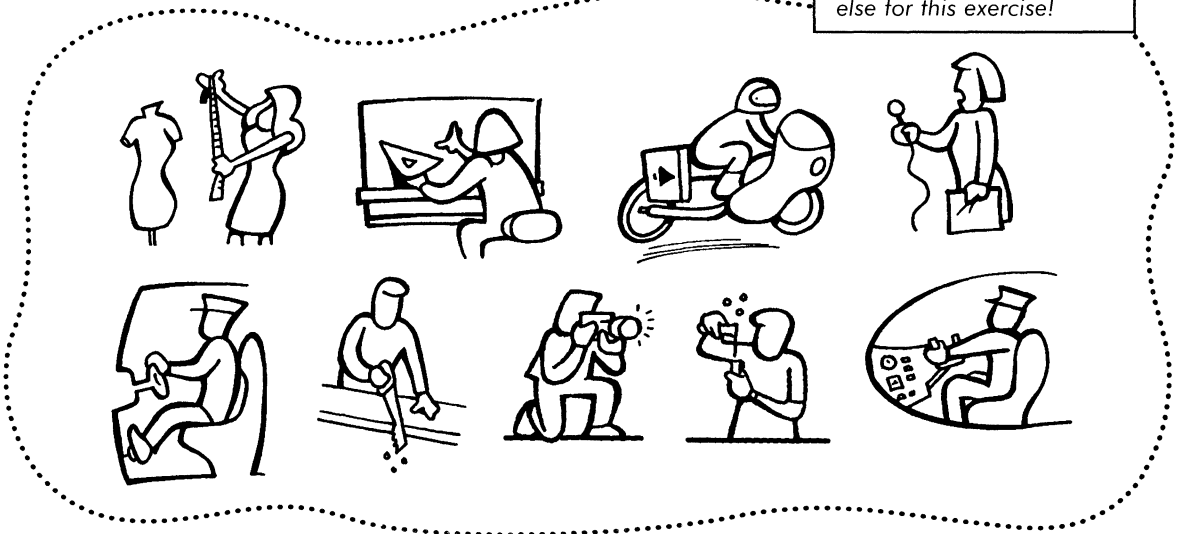

- 1 What qualifications do you need? .....
- 2 How old do you need to be? .....
- 3 What sort of a person do you need to be? .....
- 4 What about training? .....
- 5 What are the hours? .....
- 6 What's the money like? .....
- 7 What's the best bit about the job? .....
- 8 What's the worst bit? .....



7 Write ten words and five expressions you are going to memorize.

Words	Expressions
1 .....	1 .....
2 .....	2 .....
3 .....	3 .....
4 .....	4 .....
5 .....	5 .....
6 .....	6 .....
7 .....	7 .....
8 .....	8 .....
9 .....	9 .....
10 .....	10 .....

# 7 Computers

Translate the words and phrases.

## Computers

desktop computer ..... laptop .....  
 PC ..... palmtop .....

monitor ..... cursor .....  
 ..... .....

screen ..... icon .....  
 ..... .....

menu ..... window .....  
 ..... .....

toolbar ..... trash .....  
 ..... .....

hard disk ..... keyboard .....  
 ..... .....

CD-ROM drive ..... key .....  
 ..... .....

on / off button ..... cable .....  
 ..... .....

speaker ..... mouse .....  
 ..... .....

printer ..... mouse pad .....  
 ..... .....

floppy disk .....  
 ..... .....

zip disk .....  
 ..... .....

caps lock ..... back delete .....  
 ..... .....

caps (capital letters) ..... forward delete .....  
 ..... .....

return ..... scroll up .....  
 ..... .....

space bar ..... scroll down .....  
 ..... .....

numeric keypad .....  
 ..... .....



**REF** See page 87 for the British / American word list.

# Answer key

## 1 People

### Exercise 1

- 1 *f surprised*      4 b indecisive  
 2 c really happy    5 e shocked  
 3 d upset            6 a exhausted

### Exercise 2

P	N	O	R	U	D	E	B	F	E
I	M	P	A	T	I	E	N	T	S
I	M	P	U	L	S	I	V	E	H
L	I	U	F	W	O	V	L	C	Y
T	M	I	S	E	R	A	B	L	E
U	A	R	R	O	G	A	N	T	S
I	R	E	L	I	A	B	L	E	I
H	U	F	U	N	N	Y	M	S	N
O	P	T	I	M	I	S	T	I	C
Y	I	O	N	E	Z	T	G	L	E
B	Y	R	L	A	E	J	W	L	R
L	A	Z	Y	N	D	R	P	Y	E

### Possible answers

- |                   |                   |
|-------------------|-------------------|
| <b>Adjective</b>  | <b>Opposite</b>   |
| 1 <i>reliable</i> | <i>unreliable</i> |
| 2 impatient       | patient           |
| 3 disorganized    | organized         |
| 4 funny           | serious           |
| 5 lazy            | hard-working      |
| 6 mean            | generous          |
| 7 miserable       | cheerful          |
| 8 arrogant        | modest            |
| 9 optimistic      | pessimistic       |
| 10 sincere        | insincere         |
| 11 shy            | confident         |
| 12 impulsive      | cautious          |
| 13 rude           | polite            |
| 14 silly          | sensible          |

### Exercise 3

### Possible answers

😊	☹️	😊 ☹️
<i>reliable</i>	<i>impatient</i>	<i>impulsive</i>
cheerful	arrogant	cautious
confident	disorganized	serious
funny	insincere	
generous	lazy	
hard-working	mean	
modest	miserable	
optimistic	pessimistic	
organized	rude	
patient	shy	
polite	silly	
sensible	unreliable	
sincere		
3b:	bad-tempered	
easy-going	big-headed	
even-tempered	thick-skinned	
laid-back		

## Exercise 5a

- 1 *with*  
 2 of  
 3 of  
 4 of  
 5 about  
 6 by

## Exercise 5b

- 1 *anger*  
 2 jealousy  
 3 fear  
 4 pride  
 5 excitement  
 6 embarrassment

## 2 The senses

### Exercise 1

- 1 *hearing*                      4 taste  
 2 sight                            5 touch  
 3 smell

### Exercise 2

- 1a *It smells revolting.*  
 1b *But it feels soft.*  
 2a *You look beautiful.*  
 2b *But you look tired.*  
 3a *This tastes delicious.*  
 3b *But this tastes disgusting.*  
 4 *You sound very clear.*

### Exercise 3a and 3b

Q	D	Y	S	O	U	N	D	C	T
U	B	L	N	V	N	O	I	S	Y
I	N	S	P	E	C	T	Z	N	H
E	G	L	A	R	E	I	U	I	U
T	A	A	B	H	R	C	S	F	G
S	Z	P	I	E	W	E	W	F	P
T	E	S	T	A	R	E	E	M	U
I	R	S	T	R	O	K	E	S	S
N	S	M	E	L	L	I	T	C	H
K	S	C	R	A	T	C	H	W	P

- |              |                |              |              |              |
|--------------|----------------|--------------|--------------|--------------|
| <b>sight</b> | <b>hearing</b> | <b>smell</b> | <b>touch</b> | <b>taste</b> |
| inspect      | overhear       | smell        | stroke       | bitter ✓     |
| glare        | sound          | sniff        | scratch      | sweet ✓      |
| gaze         | noisy ✓        | stink        | hug          |              |
| stare        | quiet ✓        |              | itch         |              |
| notice       |                |              | push         |              |
|              |                |              | slap         |              |

### Exercise 3c

- 1 *glared*      8 overheard      15 sweet  
 2 stared      9 stroke          16 sniffed  
 3 gaze        10 scratch, itches    17 push  
 4 quiet        11 hugged          18 slapped  
 5 noisy        12 bitter            19 stinks  
 6 inspect      13 smell  
 7 notice        14 sounds



### Exercise 4

- |                  |           |         |
|------------------|-----------|---------|
| 1 <i>glanced</i> | 5 tapped  | 9 Clap  |
| 2 listening to   | 6 tickles | 10 spot |
| 3 look at        | 7 drag    |         |
| 4 have a look    | 8 push    |         |

### Exercise 5

- |                |          |
|----------------|----------|
| 1 <i>spicy</i> | 4 check  |
| 2 squeeze      | 5 smells |
| 3 hug          | 6 sour   |

### Exercise 6

- |         |          |
|---------|----------|
| 1 sound | 5 look   |
| 2 look  | 6 feel   |
| 3 feel  | 7 smells |
| 4 heard | 8 feel   |

## 3 The body and actions

### Exercise 1

- |                           |                   |
|---------------------------|-------------------|
| 1 <i>nose</i>             | 11 mouth / teeth  |
| 2 hair                    | 12 hand           |
| 3 mouth / lips / teeth    | 13 finger         |
| 4 finger / hand / foot    | 14 teeth          |
| 5 foot                    | 15 eye            |
| 6 nose / mouth / throat   | 16 mouth / lips   |
| 7 mouth / throat / tongue | 17 eye            |
| 8 hand                    | 18 mouth / lips   |
| 9 mouth / lips            | 19 nose           |
| 10 finger / hand          | 20 throat / mouth |

### Exercise 2a

- |                  |            |
|------------------|------------|
| 1 <i>swallow</i> | 6 grinned  |
| 2 snored         | 7 breathe  |
| 3 kick           | 8 Suck     |
| 4 pats           | 9 comb     |
| 5 Press          | 10 knocked |

### Exercise 2b

- |                 |
|-----------------|
| 1 <i>winked</i> |
| 2 whisper       |
| 3 sneeze        |
| 4 Chew          |
| 5 waved         |

### Exercise 3

- He's hurrying past the lion.*
- He's running towards the castle.
- They're sliding down the water chute.
- They're jumping over the stream.
- They're walking along The Yellow Brick Road.
- He's falling into the water.
- The dog's chasing the cat up the tree.
- He's looking through the wall.
- She's climbing over the wall.
- They're dancing under the tree.

### Exercise 4

- |                |            |
|----------------|------------|
| 1 <i>c</i> Lie | 6 b bite   |
| 2 j blow       | 7 a Bend   |
| 3 f shake      | 8 g Kneel  |
| 4 i Stand      | 9 d nod    |
| 5 h sit        | 10 e shake |

### Exercise 5a

- |            |      |
|------------|------|
| 1 <i>h</i> | 6 i  |
| 2 i        | 7 b  |
| 3 e        | 8 g  |
| 4 f        | 9 c  |
| 5 d        | 10 a |

### Exercise 5b

- 'You can kiss that goodbye.'*
- 'You've fallen head over heels for him.'*
- 'it's better than a kick in the teeth.'*
- 'You've bitten off more than you can chew.'*
- 'Stand your ground.'*
- 'Don't bite the hand that feeds you.'*

## 4 Health

### Exercise 1

- Flu**  
*depressed*  
 temperature  
 ache  
 runny nose  
 sore throat

### Food poisoning

- stomach ache  
 sick  
*diarrhoea*  
 headache

### Exercise 2

- |                            |                         |
|----------------------------|-------------------------|
| 1 <i>He's got earache.</i> | 5 He's got hay fever.   |
| 2 He's got a cough.        | 6 He's cut his finger.  |
| 3 He's been stung.         | 7 He's sunburnt.        |
| 4 He's got toothache.      | 8 He's grazed his knee. |

### Exercise 3a

#### Possible answers

*Can I* have an appointment (to see the doctor), please?  
 Today, if possible.  
 No, it isn't.

### Exercise 3b

- 8 b

### Exercise 3c

- |            |     |     |
|------------|-----|-----|
| 1 <i>g</i> | 4 c | 7 e |
| 2 h        | 5 f |     |
| 3 d        | 6 a |     |

### Exercise 4

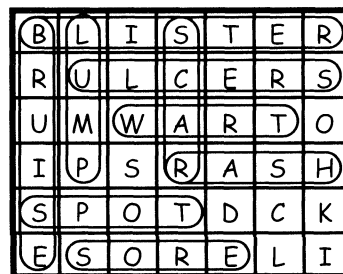

- lump*
- bruise
- spot
- cold sore
- mouth ulcers
- scar
- blister
- rash
- wart

## Exercise 5

- 1 *a cold*  
a cough  
a headache  
a nosebleed  
a sore throat  
(a) stomach ache  
a temperature
- 2a *sick*  
dizzy  
faint
- 2b allergic  
hay fever  
migraine
- 3 *fainted*  
sprained  
twisted  
broken  
burnt  
scalded
- 4 *had*  
lost  
felt  
been bitten  
had  
been stung
- 5 medicine, tablets, ointment / cream

## Test yourself 1 (Units 1 to 4)

### Exercise 1a

- 0 *surprised*  
1 jealous  
2 angry
- 3 disappointed  
4 guilty  
5 afraid

### Exercise 1b

*extrovert*, confident, impulsive, kind, loyal, reliable

### Exercise 2

- 0 *gazed*  
1 stared  
2 glanced
- 3 examined  
4 glared  
5 check
- 6 spotted / noticed  
7 searched  
8 browsed

### Exercise 3

- 0 *k*  
1 *b*  
2 *f*  
3 *c*
- 4 *j*  
5 *a*  
6 *e*  
7 *g*
- 8 *h*  
9 *d*  
10 *i / a*

### Exercise 4

Action	Part of the body	Ailments / Illnesses
nod	head	I've got a <i>headache</i> .
bite	teeth	I've got toothache.
swallow	throat	I've got a sore throat.
kick	foot	My ankle's swollen.
wave	hand	I've sprained my wrist.
bend	knee	I've grazed my knee.

### Exercise 5

- 0 *b* (*Sit down.*)  
1 *a* (*Hurry up!*)  
2 *b* (*Slow down.*)  
3 *a* (*Stand up.*)  
4 *e* (*Fold your arms.*)  
5 *g* (*Blow your nose.*)  
6 *h* (*Clear your throat.*)
- 7 *b* (*Kneel down.*)  
8 *b* (*Lie down.*)  
9 *c* (*Shake hands.*)  
10 *d* (*Cross your legs.*)  
11 *i* (*Don't lean on the gate.*)  
12 *f* (*Don't bite your nails.*)

## Exercise 6

- 0 *indigestion*  
1 allergic  
2 burned  
3 sunburnt  
4 scalded  
5 depressed
- 6 cut  
7 broken / twisted / sprained  
8 poisoning  
9 appetite  
10 dizzy

## 5 Sport

### Exercise 1

	Equipment	Sport	Location
1	<i>racket, ball</i>	tennis	court
2	(foot)ball	football	pitch
3	goggles	swimming	pool
4	stick, puck	ice hockey	rink
5	club, ball	golf	course
6	skis, sticks	skiing	piste
7	bat, ball	baseball	pitch
8	canoe, paddle	canoeing	
9	saddle, bridle	riding	
10	bow, arrow	archery	
11	mask, air cylinder	scuba diving	
12	rod, line	fishing	

### Exercise 2a

<i>innings</i>	court	doubles
throws	points	serves
score	basket	misses
hits	passing	return
catches	dribbling	bounced
Sport: baseball	shooting	volley
	throw	sets
	bounce	Sport: tennis
	Sport: basketball	

### Exercise 3

- 1 *i* *passed*  
2 *k* dribbled  
3 *c* tackle  
4 *a* passed  
5 *d* shot  
6 *e* save
- 7 *b* headed  
8 *g* scored  
9 *j* fouled / tackled  
10 *h* sent off  
11 *f* beat

### Exercise 4

Possible answers

- 1 *Fowler kicks the ball high to Owen.*  
2 Owen dribbles past two players  
3 and is tackled by Adams.  
4 Adams passes the ball to Cole  
5 but Gerrard intercepts it  
6 and heads it to Owen.  
7 Owen shoots  
8 and Seaman saves it!

## Exercise 5

- (shuttlecock) badminton  
(puck) ice hockey  
(smash) tennis
- (court) tennis, badminton, basketball  
(rink) ice skating, ice hockey  
(ring) boxing
- (15-0) fifteen – love  
(40-40) deuce  
(40A) advantage

## 6 Education and jobs

### Exercise 1

- |              |              |
|--------------|--------------|
| 1 class      | 6 homework   |
| 2 staff      | 7 assessment |
| 3 department | 8 revising   |
| 4 lessons    | 9 coursework |
| 5a marks     | 10 course    |
| 5b grade     |              |

### Exercise 3a

Age	Exams
7, 11, 14	SATs in English, Maths and Science
16	10 GCSEs Passed 9 Failed 1
17	AS levels: English, French, History, Art, Music
	<b>Plans</b>
18	A levels: English, French, History University course: Law

### Exercise 5

- |  |   |
|--|---|
| (What qualifications do you need?)         | 2 |
| (How old do you need to be?)               | 1 |
| (What sort of a person do you need to be?) | 8 |
| (What about training?)                     | 7 |
| (What are the hours?)                      | 3 |
| (What's the money like?)                   | 6 |
| (What's the best bit about the job?)       | 4 |
| (What's the worst bit?)                    | 5 |

## 7 Computers

### Exercise 1

#### Computers for beginners

- |           |             |
|-----------|-------------|
| 1 monitor | 5 trash     |
| 2 screen  | 6 keyboard  |
| 3 toolbar | 7 mouse     |
| 4 speaker | 8 mouse pad |

## Frequently Asked Questions

- on / off
- open, program, mouse, click, select
- cursor, Click, highlight, drag
- printer, toolbar, print
- close, windows, quit, menu

### Exercise 2

- 1 You close a document. 2 You close a window.
- You find and replace a word.
- You load a program.
- 1 You open a document. 2 You open a window.
- 1 You print out a document.  
2 You print out work.
- 1 You save a document. 2 You save work.
- 1 You switch on. 2 You switch off.
- You forward a document.
- You surf the net.
- You lose work.

### Exercise 3

- She pressed 'scroll up'.
- She pressed 'back delete'.
- She pressed 'return'.
- She pressed 'forward delete'.

### Exercise 4

- She's highlighted the text.
- She's inserted a symbol.
- She's replaced 'I'd' with 'My friend Tracy would'.
- She's copied and pasted the word 'really'.
- She's deleted 'really'.

### Exercise 5

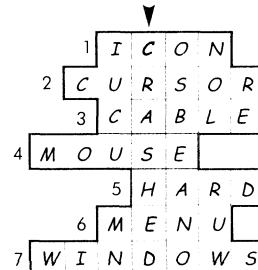

## 8 Music and drama

### Exercise 1

- |             |                  |                          |
|-------------|------------------|--------------------------|
| 1 box       | 9 prop           | 17 orchestra             |
| 2 spotlight | 10 circle        | 18 aisle                 |
| 3 gallery   | 11 trapdoor      | 19 stalls                |
| 4 balcony   | 12 wings         | 20 auditorium / audience |
| 5 curtain   | 13 dry ice       | 21 row                   |
| 6 scenery   | 14 orchestra pit | 22 seat                  |
| 7 costume   | 15 stage         |                          |
| 8 wig       | 16 footlights    |                          |

### Exercise 2

- 1 *the prompter*
- 2 the understudy
- 3 the set designer
- 4 the director
- 5 the stage hand
- 6 the playwright
- 7 a comedy
- 8 a tragedy
- 9 the dress rehearsal

### Exercise 3

- 1 *a pop festival in England, an opera house, an orchestra*
- 2 a musical, an opera, a ballet
- 3 *gig, concert, recital (ballet, musical, opera)*
- 4 *a pianist, a drummer, a guitarist, a songwriter, a conductor, a choreographer*

### Exercise 4a

Romeo and Juliet

### Exercise 5a

Possible answers

- 1 *Have you ever acted in a play?*
- 2 Which part / role did you play?
- 3 What sort of play is it?
- 4 What's it about?
- 5 Who directed it?
- 6 How many performances were there?

### Exercise 6

<sup>1</sup> P	R	O	<sup>2</sup> D	U	C	<sup>3</sup> T	I	O	N
E			R				C		
<sup>4</sup> R	E	H	E	<sup>5</sup> A	R	S	E		
F			S	E				<sup>6</sup> P	M
<sup>7</sup> O	N		<sup>8</sup> S	C	H	O	O	L	
R		<sup>9</sup> A		E			<sup>10</sup> O	<sup>11</sup> R	
<sup>12</sup> M	U	S	I	C	A	L		<sup>13</sup> T	O
A	S			R					L
N	I			<sup>14</sup> S	A	<sup>15</sup> D		E	
<sup>16</sup> C	A	S	T		A	R		S	
E		T		<sup>17</sup> P	L	A	Y	S	

## Test yourself 2 (Units 5 to 8)

### Exercise 1

FOOTBALL	BASKETBALL	TENNIS
0 <i>save</i>	1 bounce	1 racket
1 dribble	2 court	2 court
2 goal	3 dribble	3 set
3 kick	4 basket	4 smash
4 pitch	5 shoot	5 serve

### Exercise 2

- 0 *took*
- 1 marks
- 2 well
- 3 failed
- 4 retake
- 5 revision
- 6 pass
- 7 place
- 8 study / read / do
- 9 course
- 10 degree

### Exercise 3

- 0 *CV*
- 1 application
- 2 qualifications
- 3 grades / marks
- 4 interview
- 5 experience

### Exercise 4

- 0 d    1 f    2 b    3 a    4 c    5 e

### Exercise 5

- 0 *a virus*
- 1 the space bar
- 2 return
- 3 delete
- 4 the keyboard
- 5 the mouse
- 6 the speakers
- 7 the helpline
- 8 the trash
- 9 the CD-ROM drive
- 10 the hard disk

### Exercise 6

Possible answers

Two only

- 1 musical, ballet, concert, recital, gig
- 2 theatre, concert hall, opera house
- 3 balcony, circle, gallery, box, auditorium
- 4 curtain, set, scenery, lighting, footlights, props, orchestra pit, trapdoor, dry ice
- 5 band, orchestra, choir, pop group
- 6 actor, actress, director, assistant director, prompter, stage hand, understudy, stage manager, playwright
- 7 composer, performer, soloist, singer, lead singer, guitarist, drummer, keyboard player, pianist

## 9 Describing objects: shapes and materials

### Exercise 1

Noun	Adjective
1 <i>rectangle</i>	<i>rectangular</i>
2 <i>oblong</i>	<i>oblong</i>
3 circle	circular, round
4 hexagon	hexagonal
5 octagon	octagonal
6 square	square
7 cone	conical
8 triangle	triangular
9 sphere	spherical
10 cylinder	cylindrical

### Exercise 2a

Possible answers

- 1 a woollen jumper
- 2 a leather jacket
- 3 a silk scarf
- 4 a glass case
- 5 a plastic pencil case
- 6 a PVC raincoat
- 7 a perspex picture frame
- 8 a cardboard model
- 9 a ceramic jug
- 10 a brick wall

### Exercise 2b

Possible answers

- 1 a stainless steel sink
- 2 a copper bracelet
- 3 an iron bar

### Exercise 2

	<sup>1</sup> C	R	I	<sup>2</sup> C	K	E	<sup>3</sup> T
<sup>4</sup> F				R			R
<sup>5</sup> U	P		<sup>6</sup> S	O	W		U
N		<sup>7</sup> W		P		<sup>8</sup> I	N
<sup>9</sup> G	R	A	S	S			K
I		L				<sup>10</sup> T	
	<sup>11</sup> B	L	<sup>12</sup> O	S	<sup>13</sup> S	O	<sup>14</sup> M
	E		A		T		U
<sup>15</sup> B	E	E	T	L	E		D
	S		S		<sup>16</sup> M	E	

### Exercise 3a

- 1 It's a ceramic mug with a pattern on it.
- 2 It's a straight glass with a crack in it.
- 3 It's a plastic lunchbox with rounded corners.
- 4 It's a metal first-aid kit with a lid and a handle.
- 5 It's a semi-circular glass lamp.
- 6 It's a heart-shaped mirror with a wooden frame.

### Exercise 4

- 1 height = 20 cm
- 2 width = 25 cm
- 3 depth = 18 cm
- 4 volume = 9,000 cm<sup>3</sup>
- 5 area = 450 cm<sup>2</sup>

### Exercise 5

- 1 gap      4 crack
- 2 hole     5 space
- 3 slit

### Exercise 6

- 1 (a road) *bumpy*, flat, level, slippery, rough, smooth
- 2 (a pillow) firm, soft, smooth
- 3 (a piece of paper) flat, shiny, rough
- 4 (someone's hair) coarse, soft, shiny, fine

### Exercise 7

- 1 It's a plastic storage box with a lid.
- 2 It's a cylindrical plastic torch.
- 3 It's a cube-shaped clock radio with a digital display.
- 4 It's a Swiss watch with a stainless steel bracelet.

## 10 In the countryside

### Exercise 1

Possible answers

- |                                   |           |
|-----------------------------------|-----------|
| 1 birds, bushes / butterflies     | 7 rocks   |
| 2 cows                            | 8 trees   |
| 3 deer                            | 9 wall    |
| 4 field / farm / fence / footpath | 10 valley |
| 5 hedge / hill                    |           |
| 6 lane / lamb(s)                  |           |

### Exercises 3a and 3b

the earth	man-made features of the countryside	animals	crops
mud 3b: stones soil pebbles	wall 3b: bridge fence gate	cricket beetle bee 3b: birds	oats 3b: corn wheat rice

other plants	parts of tree	parts of a flower
grass fungi 3b: weeds bushes	blossom trunk 3b: branch bark	stem 3b: stalk petal flower

### Exercise 4a

Walk *along* the *track* by the fence.  
Then go up the steps and turn right at the top.

Go over the footbridge.

Don't go through the gate but turn right and walk along the footpath. Look for a signpost with 'Box Hill' on it.

Walk down the path / hill to the valley at the bottom.  
Go across the river by the stepping stones.

### Exercise 5

- 1 c) wheat
- 2 a) rice
- 3 a) leaves
- 4 c) beans
- 5 b) cattle grid
- 7 a herd; a flock
- 8 camping / walking / mountain biking

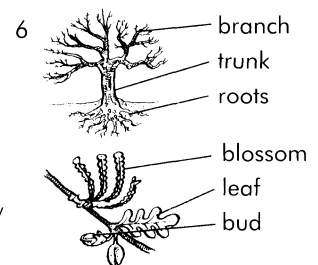

## 11 In the town

### Exercise 1

- |                  |                          |
|------------------|--------------------------|
| 1 town centre    | 6 waste ground           |
| 2 office block   | 7 industrial estate      |
| 3 tower block    | 8 out-of-town superstore |
| 4 housing estate | 9 rubbish tip            |
| 5 building site  |                          |

### Exercise 3

- |                          |                   |
|--------------------------|-------------------|
| 1 pedestrian precinct    | 10 one-way system |
| 2 advertisement hoarding | 11 litter bin     |
| 3 petrol station         | 12 traffic lights |
| 4 taxi rank              | 13 cycle lane     |
| 5 bus stop               | 14 pavement       |
| 6 multi-storey car park  | 15 bench          |
| 7 lamp post              | 16 recycling bins |
| 8 public toilets         | 17 parking meter  |
| 9 zebra crossing         | 18 parking bay    |

### Exercise 4

- a ring road / a bypass
- an underpass
- a dead end / a cul-de-sac
- the kerb
- a roundabout
- a crossroads
- a T-junction

### Exercise 5a

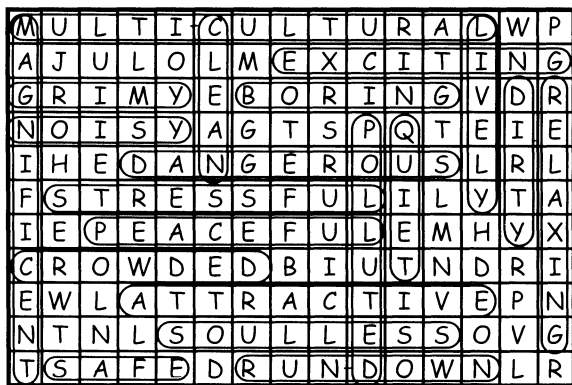

### Exercise 5b

Possible answers

#### Living in the town

multi-cultural  
crowded  
dangerous  
dirty  
exciting  
grimy  
lively  
magnificent  
noisy  
polluted  
run-down  
soulless  
stressful

#### Living in the country

attractive  
boring  
clean  
peaceful  
quiet  
relaxing  
safe

## Exercise 7a

### The good things about living in Bradford

- the National Museum of Photography
- the Hockney Gallery at Salt Mills
- attractive buildings
- ethnic shops and restaurants (it's famous for its curries)

### The bad things about living in Bradford

- the centre is quite polluted
- grimy buildings
- the nightlife

## 12 Holidays and festivals

### Exercise 1

Possible answer

Thanks for your invitation to Gemma's party. I'd be delighted to come.

### Exercise 2

- |             |                   |
|-------------|-------------------|
| 1 wig       | 6 barbecue        |
| 2 mask      | 7 Dracula make-up |
| 3 costume   | 8 candles         |
| 4 fireworks | 9 cake            |
| 5 lights    | 10 present        |

### Exercise 3

Possible answer

I've just been to the most fantastic party. It was a fancy-dress party. I dressed up in a witch's costume and I wore very scary make-up. We played party games, there was music and dancing and there was a barbecue. Everybody had a good time.

### Exercise 5

- |  |                           |
|--|---------------------------|
| 1 a hot cross buns   | Good Friday               |
| b chocolate eggs   | Easter                    |
| c lanterns made out of pumpkins                            | Hallowe'en                |
| d pancakes   | Shrove Tuesday            |
| e a decorated tree   | Christmas                 |
| f fireworks  | Guy Fawkes                |
| 2 a the period just before Easter                          | Lent                      |
| b the day when Americans celebrate the creation of the USA | Independence Day          |
| c the famous carnival in Rio de Janeiro                    | Mardi Gras                |
| d the last day of the year                                 | New Year's Eve            |
| e the first day of the year                                | New Year's Day            |
| f the day when people who work have a holiday              | Bank Holiday              |
| 3 a Guy Fawkes Night                                       | 5 <sup>th</sup> November  |
| b Hallowe'en   | 31 <sup>st</sup> October  |
| c Christmas Day  | 25 <sup>th</sup> December |
| d New Year's Day   | 1 <sup>st</sup> January   |
| e Independence Day   | 4 <sup>th</sup> July      |

### Exercise 6a

- 1 *witches*  
2 trick  
3 treat  
Hallowe'en
- 1 card  
2 heart  
3 anonymously  
Valentine's Day
- 1 presents  
2 turkey  
3 Christmas pudding  
4 tree  
5 decorations  
6 lights  
7 crackers  
Christmas Day
- 1 flowers  
2 trick  
April Fool's Day

### Exercise 7a

#### Possible answer

Mardi Gras takes place in Rio de Janeiro, Brazil, in February. It lasts for five nights and four days and it attracts hundreds of thousands of people. They dress up in fantastic costumes, they dance the samba and they have street parties. It's the biggest street carnival of them all!

## Test yourself 3 (Units 9 to 12)

### Exercise 1

- 0 a *rectangular* photo frame
- 1 a cylindrical poster tube
- 2 a triangular road sign
- 3 a square clock
- 4 a semi-circular window
- 5 a heart-shaped chocolate
- 6 a round / circular tray
- 7 a watch with an octagonal face
- 8 a conical hat
- 9 a pyramid-shaped bottle
- 10 a spherical top

### Exercise 2

- |                     |            |
|---------------------|------------|
| 0 <i>glass</i> vase | 3 crack    |
| 1 pattern           | 4 handles  |
| 2 rounded           | 5 measures |

### Exercise 3

#### Countryside

- 0 a *cattle grid*
- 1 a field
- 2 a track
- 3 a valley
- 4 corn
- 5 mud

#### Town

- 6 a one-way system
- 7 a pedestrian precinct
- 8 a tower block
- 9 a traffic jam
- 10 air pollution

### Exercise 4

- 0 *recycling bins*
- 1 litter bin
- 2 bus stop
- 3 zebra crossing
- 4 parking meter
- 5 traffic lights

### Exercise 5

- 0 *noisy / quiet*
- 1 ugly / beautiful
- 2 polluted / clean
- 3 stressful / relaxing
- 4 dangerous / safe
- 5 lively / boring

### Exercise 6

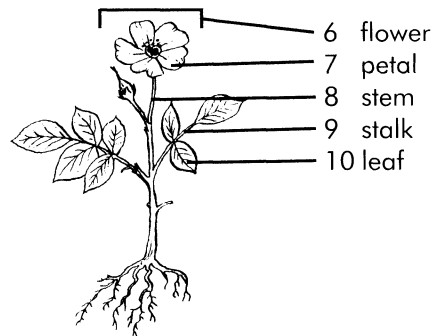
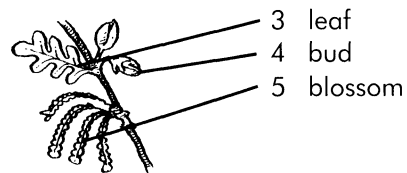
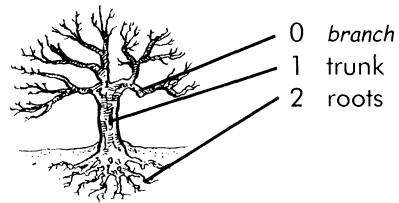

### Exercise 7

- 0 *decorate a card* with love hearts
- 1 send a card to someone anonymously
- 2 have a party
- 3 play a trick on someone
- 4 dress up as a witch or a ghost
- 5 make a Hallowe'en lantern out of a pumpkin
- 6 play 'trick or treat'
- 7 make a guy
- 8 have a bonfire party
- 9 set off fireworks
- 10 send a card to your mother

## Verb phrases associated with computers

switch on .....  
 switch off .....  
 load a program .....  
 quit a program .....  
 open a window .....  
 close a window .....  
 type a document .....  
 select text .....  
 highlight text .....  
 copy text .....

cut text .....  
 paste text .....  
 find and replace .....  
 insert a symbol .....  
 save your work .....  
 print out .....  
 use shortcuts .....  
 use the mouse .....  
 click and drag .....

I haven't got enough memory.  
 .....  
 My computer's crashed.  
 .....  
 I've lost work.  
 .....  
 The screen's frozen.  
 .....  
 My computer's got a virus.  
 .....  
 I called the helpline.  
 .....

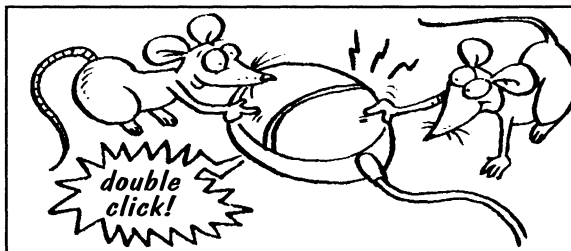
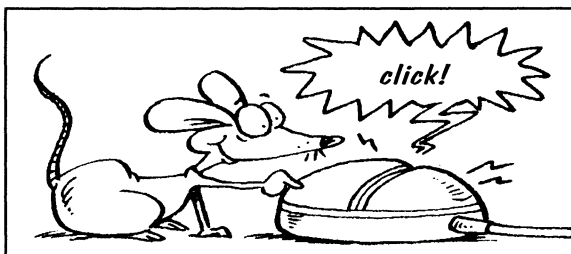

## The internet and e-mail

internet / net .....  
 service provider (ISP) .....  
 search engine .....

home page .....  
 website .....  
 password .....

I like surfing the net.  
 .....  
 I go online between 8p.m. and 8.30p.m.  
 .....  
 I e-mail my cousin regularly.  
 .....  
 I sometimes forward jokes to my friends.  
 .....

**REF** See also *Boost Your Vocabulary 2, Unit 9, Phone, e-mail and letters.*

## Computer knowledge

He's a computer genius.  
 .....  
 He's a computer nerd.  
 .....

I'm computer-literate.  
 .....  
 I'm a technophobe.  
 .....



abc ✓ 1a Complete the labels for the picture.

1b Complete the text.

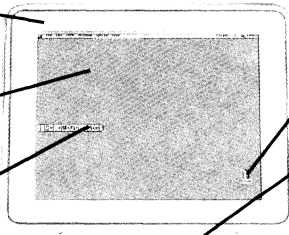

**Computers** *for beginners*

1 m onitor .....

2 s .....

3 t .....

4 s .....

5 t .....

6 k .....

7 m .....

8 m ..... p .....

### Frequently Asked Questions

- 1 *How do I switch the computer on?*  
You press the o n / a f f button.
- 2 *How do I get a new document onto the screen?*  
You o \_ \_ \_ your word-processing p \_ \_ \_ \_ \_ . You use the m \_ \_ \_ \_ to c \_ \_ \_ \_ on 'File'. Then you s \_ \_ \_ \_ \_ 'New document'. It's easy!
- 3 *Let's say I've typed a letter with three paragraphs. I decide I want to put paragraph 3 before paragraph 2. What do I do?*  
First, make sure the c \_ \_ \_ \_ \_ is positioned at the start of paragraph 3. C \_ \_ \_ \_ the mouse, hold it down and h \_ \_ \_ \_ \_ paragraph 3. Then use the mouse to d \_ \_ \_ \_ paragraph 3 before paragraph 2. And don't panic!
- 4 *How do I print out my document?*  
You just click the p \_ \_ \_ \_ \_ icon on the t \_ \_ \_ \_ \_ . Click on the options you want and then click on 'p \_ \_ \_ \_ \_'.
- 5 *When I've finished working, do I just pull the plug out of the socket?*  
NO!!! You should c \_ \_ \_ \_ all w \_ \_ \_ \_ \_ you have opened and q \_ \_ \_ \_ the program. Then go to the 'Special' m \_ \_ \_ \_ and choose 'Shut down'.

2 How many expressions can you make by matching the words and phrases in column A with those in column B?

A	B
1 close	a document
2 find and replace	a program
3 load	a window
4 open	a word
5 print out	the net
6 save	work
7 switch	off
8 forward	on
9 surf	
10 lose	

- 1 *1 You close a document. 2 You close a window.* .....
- 2 .....
- 3 .....
- 4 .....
- 5 .....
- 6 .....
- 7 .....
- 8 .....
- 9 .....
- 10 .....

3 Which key did Tracy press? ( | shows the position of the cursor.)

'return'	'scroll up'	'back delete'	'forward delete'
----------	-------------	---------------	------------------



- e-mail: tracy@teenmail.com|
- Dear Brad|
- Dear Brad
- 1 *She pressed 'scroll up'.* .....
- Dear Bradd|
- Dear Brad|
- 2 .....
- Dear Brad|
- |
- 3 .....
- Dear Brad
- Dear Brad
- I'm writing|to ask
- I'm writing|
- 4 .....

4 What has Tracy done now? Use the words in the box to describe what has happened.

delete   copy and paste   highlight   insert / symbol   replace ... with ...

I'd really like to meet you.

1 *She's highlighted the text.*

I'd really like 😊 to meet you.

2 .....

My friend Tracy would really like 😊 to meet you.

3 .....

My friend Tracy would really  
 really  
 really  
 really like 😊 to meet you.

4 .....

My friend Tracy would like 😊 to meet you.

5 .....



5 Tracy couldn't send her message because something went wrong. Solve the puzzle to find out what it was.

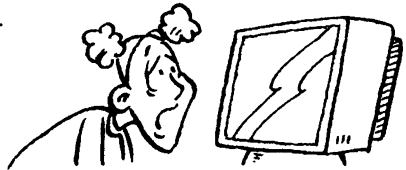

Her computer .....

- 1 A small picture like this or this . (4)
- 2 It shows you where you are about to type. (6)
- 3 Electricity travels along it. (5)
- 4 You use it to move 2 around the screen. (5)
- 5 The computer stores information on this disk. (4)
- 6 You find it in a restaurant and at the top of your screen. (4)
- 7 They're on a computer and in a house – and you can open and close them. (7)

↓

1	I	C	O	N		
2						
3						
4						
6						
7						

**6** Try this questionnaire to find out how much you know about computers.

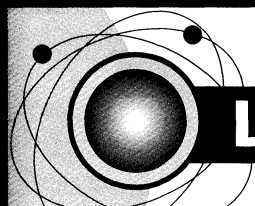

# Log on...

## Questionnaire

Circle A, B or C.

- Print
- Text
- Search
- Favourites
- Home

- 1 *How long do you spend online each week?*  
**A** More than 10 hours  
**B** Between 5 and 10 hours  
**C** Less than 5 hours
- 2 *How many e-mails do you send each week?*  
**A** More than 20 **B** Between 5 and 20  
**C** Fewer than 5
- 3 *How many programs do you know how to use?*  
**A** More than 5 **B** Between 1 and 5 **C** 0-1
- 4 *How many search engines do you use on a regular basis?*  
**A** More than 5 **B** Between 1 and 5 **C** 0-1
- 5 *Have you got your own website?*  
**A** Yes, of course **B** Not yet **C** What's a website?

- 6 *Do you know how much memory your computer has got?*  
**A** Of course **B** No, but I know how to find out  
**C** I can't remember
- 7 *Do you ever forward e-mails?*  
**A** Yes, I forward lots of jokes **B** Yes, sometimes  
**C** No
- 8 *Do you know how to attach a document to an e-mail?*  
**A** Yes, for both PCs and Macs **B** Yes **C** Sorry?
- 9 *Has your computer got a DVD-ROM drive?*  
**A** Of course **B** No, but I'd like one **C** A what?
- 10 *How often have you phoned the helpline in the past six months?*  
**A** Never **B** Occasionally  
**C** They know me by name
- 11 *Do you use shortcuts?*  
**A** Yes, lots **B** A few **C** I'm bored now
- 12 *Do you save your work onto floppy disks or zip disks?*  
**A** Zips. Who uses floppies nowadays?  
**B** Floppy disks **C** Zzzzzzz

### ANALYSIS

- Mostly As** Are you a genius or a nerd?
- Mostly Bs** You know enough to get by, and perhaps even more. Well done!
- Mostly Cs** You're either a technophobe or you're so creative that you think computers are a waste of time.



**7** Write ten words and five expressions you are going to memorize.

Words	Expressions
1 .....	1 .....
2 .....	.....
3 .....	2 .....
4 .....	.....
5 .....	3 .....
6 .....	.....
7 .....	4 .....
8 .....	.....
9 .....	5 .....
10 .....	.....

# 8 Music and drama

Translate the words and phrases.

## Types of performance

- |                 |                             |
|-----------------|-----------------------------|
| play .....      | ballet .....                |
| show .....      | concert .....               |
| pantomime ..... | recital .....               |
| musical .....   | gig (pop, rock music) ..... |
| opera .....     | festival .....              |

## Places

- |                    |                        |
|--------------------|------------------------|
| theatre .....      | venue .....            |
| concert hall ..... | stadium .....          |
| opera house .....  | open-air concert ..... |

## Music

### Performing

- practise (*verb*) .....
- practice (*noun*) .....
- give a concert .....

### People in music

- composer .....
- songwriter .....
- conductor .....
- performer .....
- musician .....
- band .....
- orchestra .....
- soloist .....
- singer .....
- lead singer .....
- backing group .....
- guitarist .....
- drummer .....
- keyboard player .....
- pianist .....
- choir .....

### People in dance

- choreographer .....
- dancer .....
- ballet dancer .....
- ballerina .....

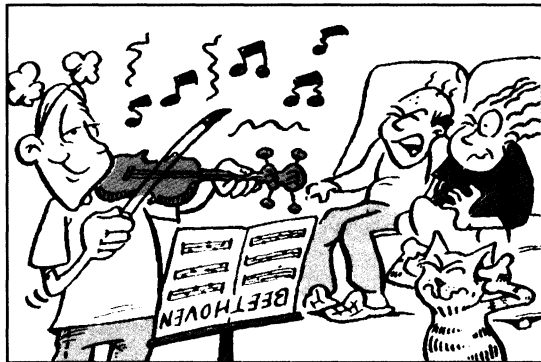

REF

See page 87 for the British / American word list.

## Drama

### Parts of a theatre

foyer .....  
auditorium .....  
box .....  
stalls (*always plural*) .....  
circle .....  
balcony .....  
gallery .....  
aisle .....  
row .....  
seat .....

### The stage

stage .....  
curtain .....  
set .....  
scenery .....  
lighting .....  
lights .....  
footlights .....  
prop .....  
orchestra pit .....  
wings .....  
trapdoor .....  
dry ice .....

### Plays

comedy .....  
tragedy .....  
production .....  
performance .....

### People

playwright .....  
actor / actress .....  
director .....  
assistant director .....  
set designer .....  
prompter .....  
stage hand .....  
understudy .....  
stage manager .....  
cast .....

### Parts of a drama

first act .....  
interval .....  
second act .....  
scene .....

### Performing

rehearse .....  
act / be / appear  
in a play .....  
be on stage .....  
play the part of /  
take the role of .....

character .....  
costume .....  
wig .....

dress rehearsal .....  
first night .....  
audience .....  
applause .....  
encore .....

### Describing a drama / a performance

The plot is simple / complicated.  
.....

The play is set in Venice / in the 1960s.  
.....

It was written by ...  
.....

It's about ...  
.....

It ends with ...  
.....

REF

See *Boost Your Vocabulary 2, Unit 6, Cinema, television and radio: Talking about films.*

abc 1 Label the picture.

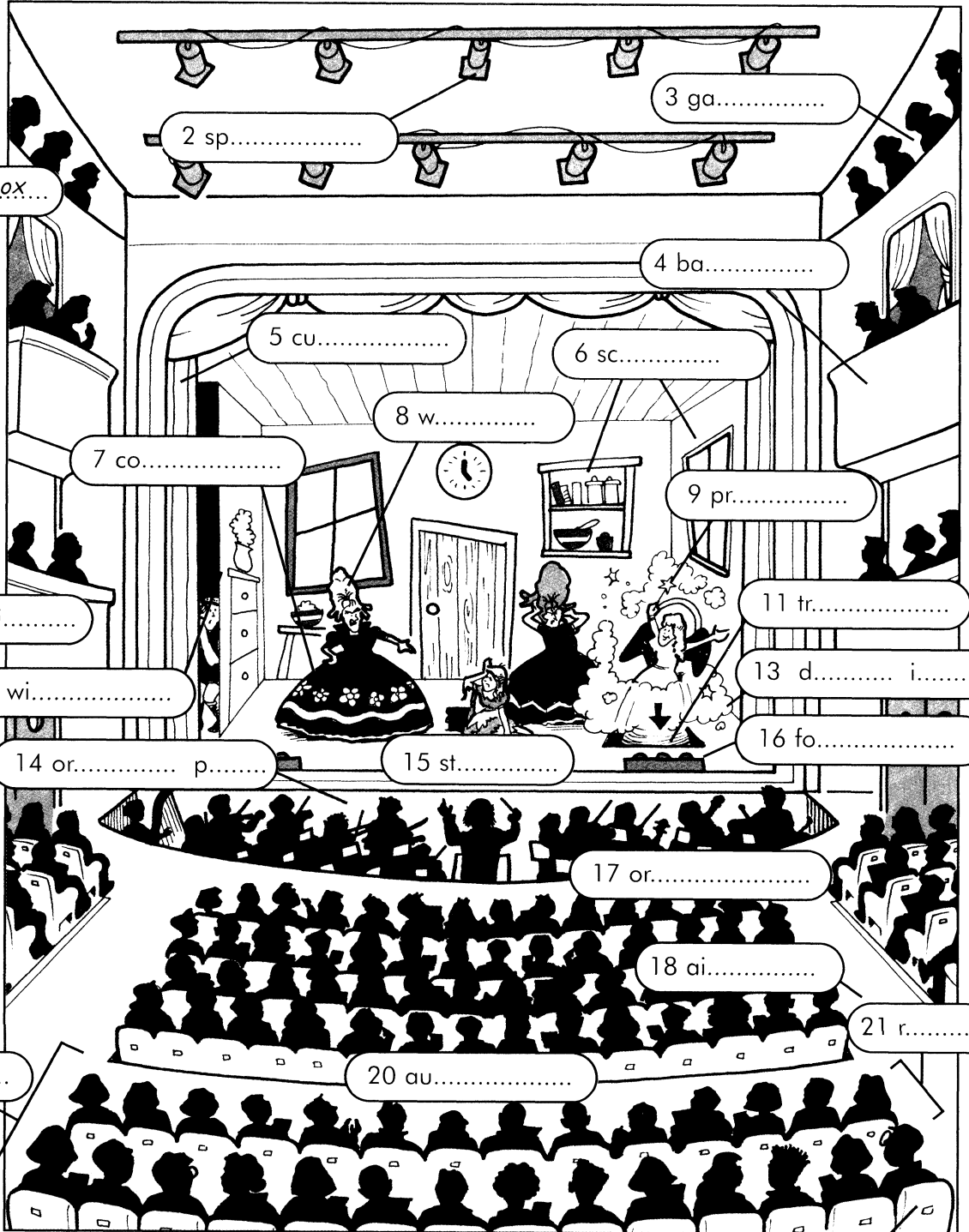

1 box...

2 sp.....

3 ga.....

4 ba.....

5 cu.....

6 sc.....

8 w.....

7 co.....

9 pr.....

10 ci.....

11 tr.....

12 wi.....

13 d..... i.....

14 or..... p.....

15 st.....

16 fo.....

17 or.....

18 ai.....

21 r.....

19 st.....

20 au.....

22 se.....

2 Try this theatre quiz.

**Quiz** How much do you know about the theatre?

**What do you call**

- 1 the person who helps if actors forget their lines? *the prompter*.....
- 2 the person who learns a part in case an actor is ill? .....
- 3 the person who designs the scenery? .....
- 4 the person who decides how the actors should play their parts? .....
- 5 the person who helps to put up the scenery and move it around? .....
- 6 the person who writes a play? .....
- 7 a play which is funny? .....
- 8 a play which is sad? .....
- 9 the rehearsal which the actors do in costume? .....

3 Now try this music quiz.

**Quiz** How musical are you!

- 1 What is Glastonbury? *a pop festival in England*.....  
 la Scala? .....
- 2 What is *Cats*? .....
- Carmen*? .....
- Swan Lake*? .....
- 3 Name three types of musical performance *gig*.....  
 .....  
 .....
- 4 He / She plays the piano *a pianist*.....  
 plays the drums .....
- plays the guitar .....
- writes songs .....
- beats time for the orchestra .....
- plans dance movements .....

TOTAL (for exercises 2 and 3) = 20 points. Check your answers on page E of the Answer key.

**Analysis**

- 15–20 points So that’s why you don’t do your homework – you’re always at the theatre or a concert.
- 8–14 points You probably won’t be a performer, but you enjoy being in the audience.
- 1–7 points Switch the computer off and get out more!



#### 4a Which play is being described?

The play is a tragedy. It was written by William Shakespeare. It's set in Verona, in Italy. It's about two young people who are in love. The problem is that their families are enemies. The young woman's father wants her to marry someone else. The play ends with both the young man and the young woman killing themselves. In 1997, the story was made into a film starring Leonardo DiCaprio.

.....



#### 4b Write a summary of a play or musical without giving the name. Then ask a friend to guess what it is.

The play is a ...

(The problem is ...)

It was written by ...

The play ends with ...

It's set in ...

(Say if it has been made into a film.)

It's about ...

#### 5a What were the questions in this interview? Write them in.

1 <i>Have you ever acted in a play?</i> .....	Yes, I was in Cinderella, in my first year at secondary school.
2 .....	I played one of the Ugly Sisters.
3 .....	It's a pantomime.
4 .....	The plot is very simple. The two Ugly Sisters are jealous of their beautiful sister, Cinderella. They won't let her go to Prince Charming's party. But Cinderella's fairy godmother helps her. She goes to the party and meets the prince, who falls in love with her.
	
5 .....	Mr Lawrence, the drama teacher. He's a brilliant director.
6 .....	There were three: on Wednesday, Thursday and Friday.



#### 5b If you have acted in a play, give your own answers to the questions.



## 6 Solve this crossword.

### Across ▶

- 1 I was in *Romeo and Juliet* at school, but I've never seen a professional ... . (10)
- 4 To practise a play. (8)
- 6 The play starts at 7.30 ... . (2)
- 7 Hurry up! You're ... stage in 10 seconds! (2)
- 8 To become an actor, you need to go to drama ... . (6)
- 10 Which do you prefer: classical ... pop music? (2)
- 12 A play with singing. (7)
- 13 I want ... be an actor. (2)
- 14 A tragedy has a ... ending. (3)
- 16 All the actors in a play. (4)
- 17 She ... the keyboards in a band. (5)

1	P	R	O	2	D	U	C	T	3	I	O	N
4						5						
										6		
7				8								
			9							10	11	
12										13		
						14			15			
16												
					17							

### Down ▼

- 1 Please take your seats, as tonight's ... is about to begin. (11)
- 2 and 5 Before the first night, the actors put their costumes on and have a ... .. (5, 9)
- 3 See 15 Down
- 5 See 2 Down
- 6 The story of a play. (4)
- 9 The assistant director's job is to ... the director. (6)
- 11 Another word for the parts an actor plays. (5)
- 15 and 3 It looks like smoke or steam on the stage. (3, 3)

	<b>SHAKEPEARE'S GLOBE</b> <small>New Globe Walk London</small>
	<b>KING LEAR</b> Thur 6 Sept 2001 19:30 Top Gallery
£25.00	<b>E12</b>

## 7 Write ten words and five expressions you are going to memorize.

Words	Expressions
1 .....	1 .....
2 .....	.....
3 .....	2 .....
4 .....	.....
5 .....	3 .....
6 .....	.....
7 .....	4 .....
8 .....	.....
9 .....	5 .....
10 .....	.....

# Test yourself 2 (Units 5 to 8)

How much can you remember?

My mark: 60

1 Put the words into the correct groups. Some words can be used more than once.

save	court	smash	basket	pitch
racket	set	goal	kick	shoot
bounce	dribble	serve		



## FOOTBALL

- 0 *save* .....
- 1 .....
- 2 .....
- 3 .....
- 4 .....
- 5 .....



## BASKETBALL

- 1 .....
- 2 .....
- 3 .....
- 4 .....
- 5 .....



## TENNIS

- 1 .....
- 2 .....
- 3 .....
- 4 .....
- 5 .....

(15 marks)

2 Complete the text about Danielle.

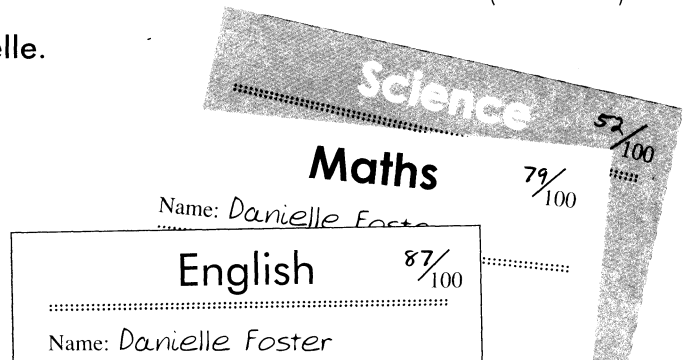

Danielle <sup>0</sup> *took* ..... exams in English, Maths and Science. She got good

**PASS MARK 60/100** **87/100**

<sup>1</sup> ..... in English.

She did **PASS MARK 60/100** **79/100** <sup>2</sup> ..... in Maths. But she

**PASS MARK 60/100** **52/100** <sup>3</sup> .....

Science, so she's going to

<sup>4</sup> ..... it later this year. She says she'll do more <sup>5</sup> ..... this

time, so she should <sup>6</sup> ..... She's hoping to get a <sup>7</sup> ..... at

York University to <sup>8</sup> ..... Medicine. Medicine is a five-year

<sup>9</sup> ..... If at the end of it she gets her



<sup>10</sup> ....., she wants to work in a children's hospital.

(10 marks)







### 3 Complete the article.

#### Replying to a job advertisement

Sometimes employers ask you to send your <sup>0</sup> CV, giving details of your education and career, but usually you have to fill in an <sup>1</sup> form. For most office jobs, you need to have <sup>2</sup> in Maths and English. Make sure you give details of when you took your Maths and English <sup>3</sup>, and what <sup>4</sup> you got. If the employers want to see you, they will ask you to come for an <sup>5</sup>. They will want to know if you have any previous <sup>6</sup> which makes you suitable for the job.

(6 marks)

### 4 Match the symbols with their meanings.

0 	2 	4 	a highlight text	e save your work to disk
1 	3  text	5 	b paste text	f cut text
			c printer	
			d copy text	

0 ..d.. 3 .....

1 .....

2 .....

4 .....

5 .....

(5 marks)

### 5 How much can you remember about computers? Write in the answers.

- 0 You don't want your computer to get this. *a virus* .....
- 1 You press it when you want to put a space between words. ....
- 2 You press it when you want to move to the next line down. ....
- 3 You press this key to remove text. ....
- 4 You type on this. ....
- 5 You use it to move the cursor around the screen. ....
- 6 You hear sound through them. ....
- 7 You phone this service when you've got problems. ....
- 8 You put documents you don't want in here. ....
- 9 You put your CD-ROMs in here. ....
- 10 You save work onto this disk inside your computer. ....

(10 marks)

### 6 Write the names of two more ...

- 1 kinds of musical performance: *opera* .....
- 2 places for performances of music or drama: *stadium* .....
- 3 places you can sit in a theatre: *stalls* .....
- 4 things you find in a theatre: *wings* .....
- 5 groups of musicians: *backing group* .....
- 6 people who work in a theatre: *set designer* .....
- 7 individual musicians: *songwriter* .....







(14 marks)

# 9 Describing objects: shapes and materials

Translate the words and phrases.

## Two-dimensional shapes

### Nouns

-  square .....
-  rectangle / oblong .....
-  circle .....
-  semi-circle .....
-  triangle .....
-  hexagon .....
-  octagon .....

### Adjectives

- square .....
- rectangular / oblong .....
- circular, round .....
- semi-circular .....
- triangular .....
- hexagonal .....
- octagonal .....

### -shaped

-  diamond-shaped .....
- or: in the shape of a diamond
-  crescent-shaped .....
-  heart-shaped .....

## Three-dimensional shapes

### Nouns





-  cone .....
-  sphere .....
-  cylinder .....
-  pyramid .....
-  cube .....

### Adjectives

- conical .....
- spherical .....
- cylindrical .....
- (pyramid-shaped) .....
- (cube-shaped) .....



## Edges, corners and points

-  straight .....
-  crooked .....
-  with rounded corners .....
-  pointed .....

## Metals and other materials

metal .....  
 gold .....  
 silver .....  
 brass .....  
 copper .....  
 steel .....  
 iron .....  
 stainless steel .....  
 aluminium .....  
 tin .....

glass .....  
 plastic .....  
 PVC .....  
 perspex .....  
 paper .....  
 card .....  
 cardboard .....  
 ceramic .....  
 brick .....  
 wood .....

**REF**

See also *Boost Your Vocabulary 2, Unit 8*, for materials and patterns.

*These nouns have identical adjectives, except wood (adjective wooden). e.g. a gold watch (adjective); it's made of gold (noun).*

## Parts of an object

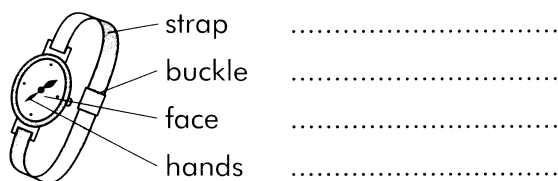
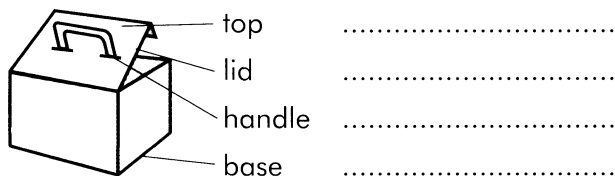

## Surfaces and textures

flat .....  
 level .....  
 smooth .....  
 shiny .....  
 slippery .....  
 bumpy .....

soft .....  
 fine .....  
 firm .....  
 rough .....  
 coarse .....

## Openings

gap .....  
 slit .....  
 hole .....  
 crack .....  
 space .....

## Measuring

ruler .....  
 tape measure .....  
 height .....  
 width .....  
 depth .....  
 area .....  
 volume .....

## Describing objects

It measures about 30cm by 10cm.  
 .....  
 It's made of plastic.  
 .....  
 It's got a pattern on it.  
 .....  
 It's got a crack in it. / It's cracked.  
 .....  
 It's a stainless steel watch with a glass face.  
 .....

**REF**

See page 85 for units of measurement.  
 See page 87 for the British / American word list.



1 Find ten nouns in the wordsearch and match them to the shapes. Then write in the corresponding adjectives.

O	B	L	O	N	G	I	C	P
T	H	O	C	O	N	E	Y	K
R	E	C	T	A	N	G	L	E
I	X	T				C	I	S
A	A	A				I	N	P
N	G	G				R	D	H
G	O	O				C	E	E
L	N	N				L	R	R
E	S	Q				U	A	R
						E	O	E

	Picture	Noun	Adjective
1		<i>rectangle</i>	<i>rectangular</i>
2		<i>oblong</i>	<i>oblong</i>
3		.....	.....
4		.....	.....
5		.....	.....
6		.....	.....
7		.....	.....
8		.....	.....
9		.....	.....
10		.....	.....



2a Can you think of ten more things made of different materials?

	<i>a wooden floor</i>	<i>a cotton sheet</i>	
1	.....	6	.....
2	.....	7	.....
3	.....	8	.....
4	.....	9	.....
5	.....	10	.....



2b Can you think of three more things made of different types of metal?

	<i>a brass buckle</i>	2	.....
1	.....	3	.....

3a Look at the objects and complete the words for describing them. Then write a sentence about each one.

1 c \_ \_ \_ m \_ c  
p \_ t t \_ \_ n



mug

It's a ceramic mug with a pattern on it.

2 s \_ r \_ \_ g \_ t  
c r \_ \_ k

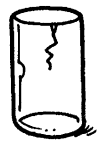

glass

3 p l \_ \_ \_ \_ c  
r \_ \_ \_ d \_ d  
c \_ \_ n \_ \_ s



lunchbox

4 m \_ t \_ l  
l \_ d  
h \_ \_ \_ l \_

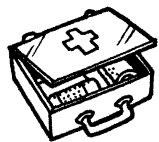

first-aid kit

5 s \_ m \_ c \_ \_ \_ \_ l \_ r  
g l \_ \_ s

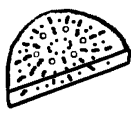

paperweight

6 h \_ \_ \_ t - s h \_ p \_ d  
w \_ \_ \_ \_ n



mirror frame

3b Either

Have you got an object at home similar to one of those above? Draw it in the box and describe it.

It's a  
.....  
.....  
.....  
.....

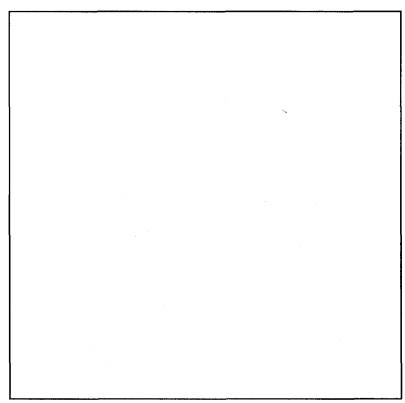

or

Describe an object for a friend to draw. How accurate is their picture?



Look at the objects and complete the words. Then write the correct measurement for each one.

abc ✓

4 Complete the measuring words and then give the correct measurements for the box.

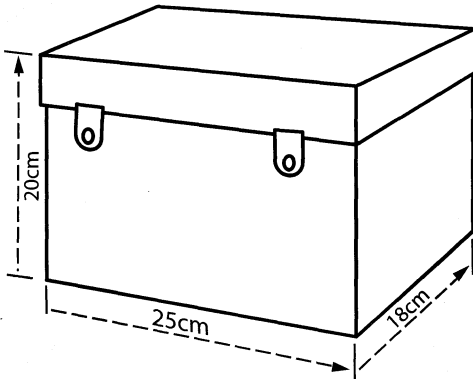

1 h \_\_\_\_\_ = ..... cm

2 w \_\_\_\_\_ = ..... cm    3 d \_\_\_\_\_ = ..... cm    5 a \_\_\_\_\_ = 450cm<sup>2</sup>

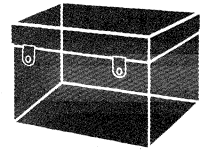

4 v \_\_\_\_\_ = 9,000cm<sup>3</sup>

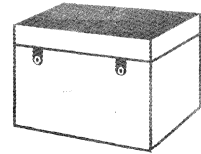

5 Which is which?

crack	gap	space	hole	slit
-------	-----	-------	------	------



1 a *gap* in the hedge

2 a ..... in the ground

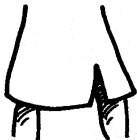

3 a skirt with a ..... up the side

4 a ..... in the glass



5 a ..... on the luggage rack

6 Which of the words in the box can you use to describe



1 a road? *bumpy* .....

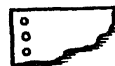

3 a piece of paper? .....



2 a pillow? .....



4 someone's hair? .....

coarse	firm	bumpy	flat	soft	shiny
level	slippery	rough	smooth	fine	

7 Describe these articles.



(material? purpose? other features?)

1 *It's a plastic storage box with a lid.*

box for storage

(shape? material?)

2 .....



torch plastic



(shape? other features?)

3 .....

clock-radio digital display

(country of origin? other features?)

4 .....



watch

country of origin: Switzerland  
bracelet: stainless steel

8 Read these descriptions. Then describe your watch.



a) I've got a plastic watch with a plastic strap. It's got a picture of a cat on the face, and the second hand has got a mouse on the end of it.

b) I've got a sports watch with a nylon strap. It's got a digital display.

c) .....  
.....  
.....

9 Write ten words and five expressions you are going to memorize.

Words	Expressions
1 .....	1 .....
2 .....	2 .....
3 .....	3 .....
4 .....	4 .....
5 .....	5 .....
6 .....	6 .....
7 .....	7 .....
8 .....	8 .....
9 .....	9 .....
10 .....	10 .....

# 10 In the countryside

Translate the words and phrases.

## Features of the countryside

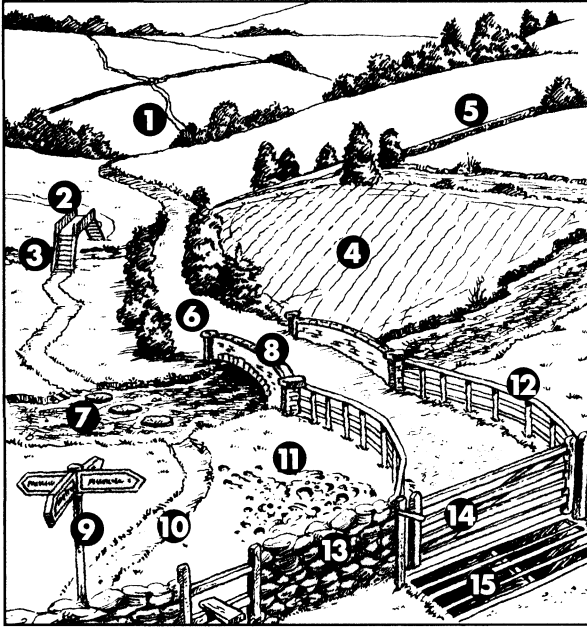

- 1 track .....
- 2 footbridge .....
- 3 steps .....
- 4 field .....
- 5 hedge .....
- 6 lane .....
- 7 stepping stones .....
- 8 bridge .....
- 9 signpost .....
- 10 footpath .....
- 11 mud .....
- 12 fence .....
- 13 (dry stone) wall .....
- 14 gate .....
- 15 cattle grid .....

- tree .....
- bush .....
- grass .....
- flower .....
- fungus (fungi) .....
- butterfly .....

- bird .....
- bee .....
- ant .....
- beetle .....
- grasshopper / .....
- cricket .....

### Parts of a plant

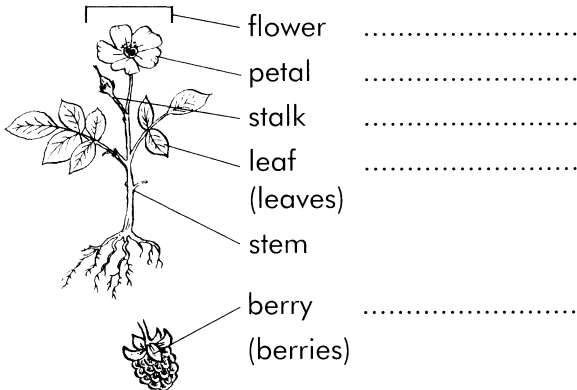

### Parts of a tree

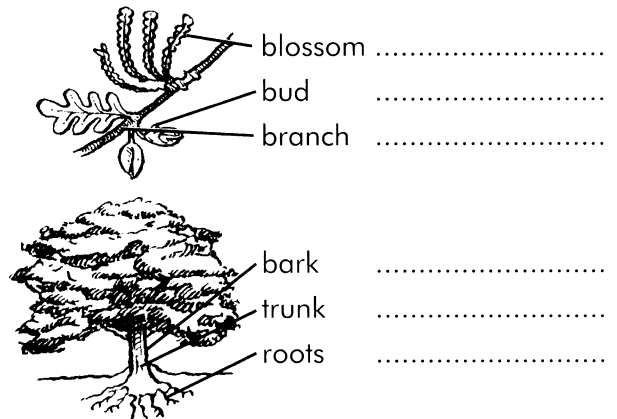

## The earth

ground (U)	.....	stones	.....
soil (U)	.....	pebbles	.....
rocks	.....	sand (U)	.....

REF

See also *Boost Your Vocabulary 2, Unit 11, Landscape and weather.*

*U = a noun which is uncountable in this context*

## Describing landscape features

a steep hill	.....
a deep valley	.....
a thick / dense forest	.....
long grass	.....
overgrown (with weeds)	.....

## Groups of animals

herd (of cows, cattle, deer)	.....
flock (of sheep, goats, birds)	.....

*Deer and sheep are both singular and plural. Cattle is a plural noun meaning cows and bulls.*

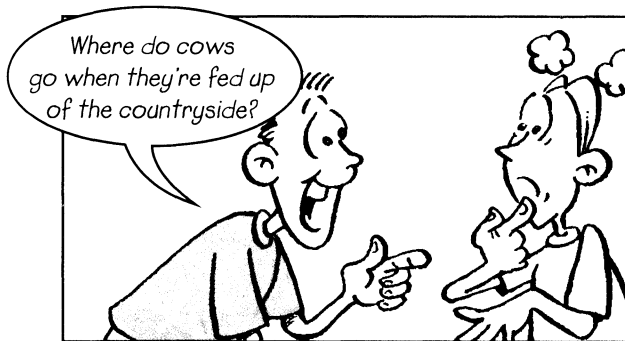

## Cereal crops

corn (U)	.....
barley (U)	.....
oats	.....
rye (U)	.....
wheat (U)	.....
maize (U)	.....
rice (U)	.....

*In British English, corn = cereal crops grown in Britain (especially wheat, oats and barley). In other varieties of English, corn = maize.*

## Growing and harvesting

grow (crops)	.....
sow (seed)	.....
plant (potatoes)	.....
harvest (corn)	.....
pick (apples)	.....

## Countryside activities

get some fresh air	.....
go for a walk	.....
go hiking	.....
go camping	.....
go mountain-biking	.....

REF

See page 87 for the British / American word list.



1 Find things in the picture beginning with these letters.

- |   |          |                    |    |          |       |
|---|----------|--------------------|----|----------|-------|
| 1 | <b>b</b> | <i>birds</i> ..... | 6  | <b>l</b> | ..... |
| 2 | <b>c</b> | .....              | 7  | <b>r</b> | ..... |
| 3 | <b>d</b> | .....              | 8  | <b>t</b> | ..... |
| 4 | <b>f</b> | .....              | 9  | <b>w</b> | ..... |
| 5 | <b>h</b> | .....              | 10 | <b>v</b> | ..... |

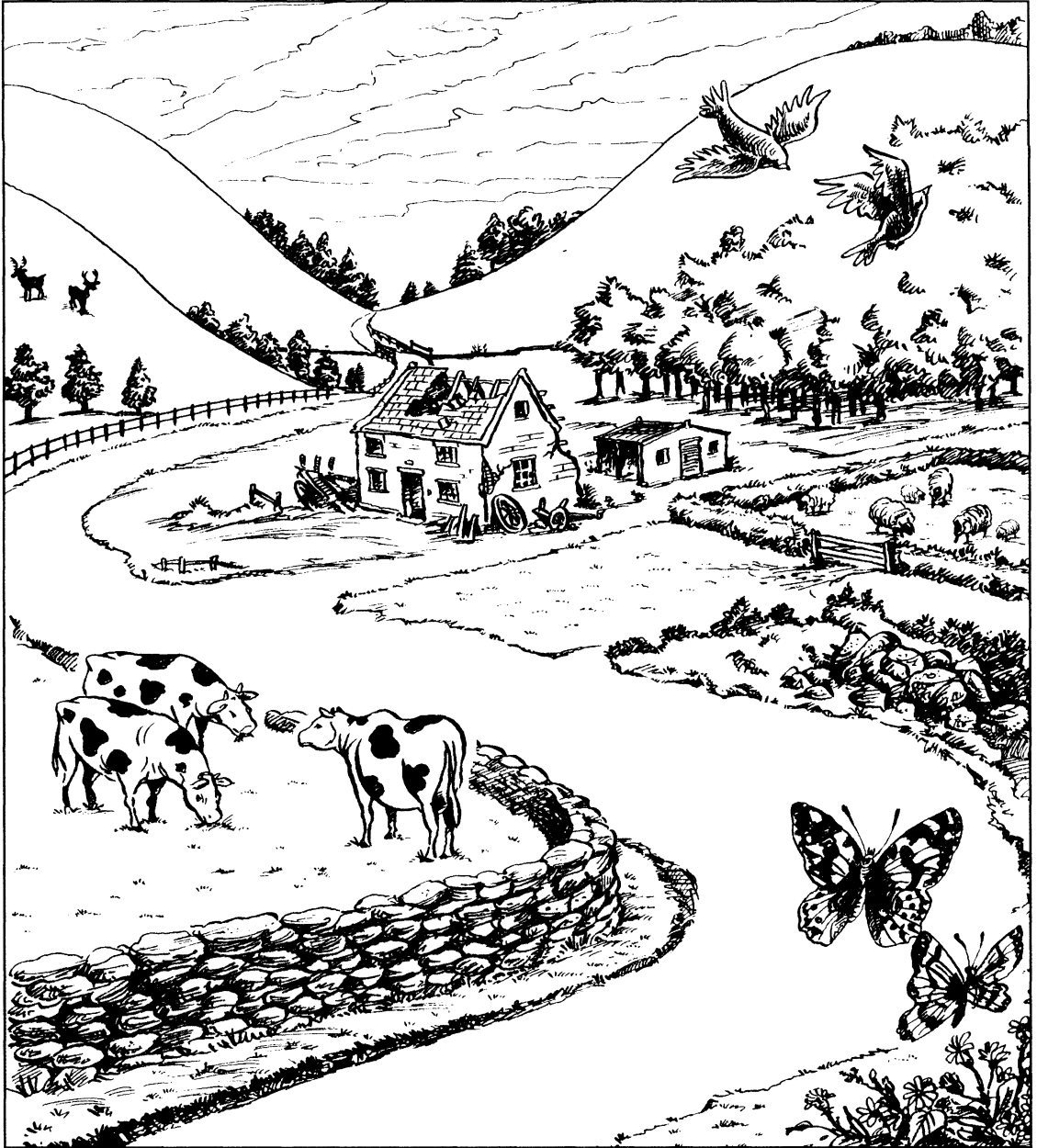



## 2 Solve the crossword.



### Across ▶

- 1 It's similar to a grasshopper. (7)
- 5 You go down to the valley and then ..... the hill. (2)
- 6 You ..... seed in the spring. (3)
- 8 We went hiking ..... the mountains. (2)
- 9 You find it in a field, and it's green. (5)
- 11 The flowers on a tree. (7)
- 15 An insect which sounds like a member of a famous pop group from Liverpool but is spelt differently! (6)
- 16 Come for a walk with ..... . (2)

	1	C	R	I	2	C	K	E	3	T
4										
5				6						
			7					8		
9										
								10		
	11			12			13			14
15										
								16		

### Down ▼

- 2 They grow in fields and we make food, like breakfast cereals, from them. (5)
- 3 The biggest part of a tree. (5)
- 4 Mushrooms belong to this plant group. (5)
- 7 We're helping to build a dry stone ..... . (4)
- 10 I'm going out ..... get some fresh air. (2)
- 11 Insects which buzz. (4)
- 12 A cereal. Horses like to eat them. (4)
- 13 The leaves of a flower are attached to it. (4)
- 14 Water + soil = ..... . (3)



## 3a Find words in the crossword to put into the following groups.

the earth	man-made features of the countryside	animals	crops	other plants	parts of a tree	parts of a flower
.....	.....	<i>cricket</i>	.....	.....	.....	.....
.....	.....	.....	.....	.....	.....	.....
.....	.....	.....	.....	.....	.....	.....
.....	.....	.....	.....	.....	.....	.....



## 3b Add these words to the correct group in exercise 3a.

- bark
- birds
- branch
- bridge
- bushes
- corn
- fence
- flower
- gate
- pebbles
- petal
- rice
- soil
- stalk
- stones
- weeds
- wheat



**4a** Describe this walk, using prepositions of motion (see Unit 3 page 19) and words for features of the landscape.

(P = preposition of motion; L = feature of the landscape)



Walk (P) *along* ..... the  
 (L) *track* ..... by the  
 (L) .....  
 Then go (P) ..... the  
 (L) ..... and turn right at  
 the top.



Go (P) ..... the  
 (L) .....



Don't go (P) ..... the  
 (L) ..... but turn right and  
 walk (P) ..... the  
 (L) ..... Look for a  
 signpost with 'Box Hill' on it.



Walk (P) ..... the  
 (L) ..... to the valley at the  
 bottom. Go (P) ..... the  
 (L) ..... by the (L)  
 .....



**4b** Draw the route of a favourite walk. Describe the route for a friend.

5 Try this nature quiz.

# Nature Quiz



- 1 Which cereal is pasta made from?  
a) corn b) oats c) wheat
- 2 Name a cereal which is eaten widely in Asia.  
a) rice b) barley c) rye
- 3 Which part of the tea plant is tea made from?  
a) leaves b) roots c) flowers
- 4 Where does coffee come from?  
a) berries b) leaves c) beans
- 5 It's made of metal, it's in the ground and it stops cows getting out of a field. What is it called?  
a) stepping stones b) cattle grid c) track
- 6 Label the parts of this tree:
- 7 What is a group of cows or deer called?  
.....  
What is a group of sheep or birds called?  
.....
- 8 Name two more countryside activities:  
*hiking*.....
- 9 Name three crops that are grown in your country.  
.....  
When are they sown / planted? When are they harvested / picked?  
.....  
.....

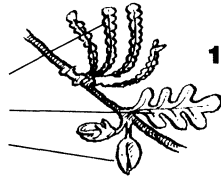
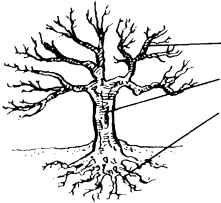

- 10 Think of the landscape of your country. Name:  
a dense forest .....  
a deep valley .....  
a steep hill .....

Check your answers for questions 1–8 on page F of the Answer key.

**ANALYSIS**

11–15 correct answers: You enjoy country life, don't you?

6–10 correct answers: You're at home both in town and country.

1–5 correct answers: Just don't leave the city!

6 Write ten words and five expressions you are going to memorize.

Words	Expressions
1 .....	1 .....
2 .....	.....
3 .....	2 .....
4 .....	.....
5 .....	3 .....
6 .....	.....
7 .....	4 .....
8 .....	.....
9 .....	5 .....
10 .....	.....



# 11 In the town

Translate the words and phrases.

## The built environment

town centre .....  
 suburbs .....  
 office block .....  
 tower block .....  
 housing estate .....  
 building site .....  
 factory .....  
 waste ground .....  
 industrial estate .....  
 (out-of-town) .....  
 superstore .....  
 rubbish tip .....

## The town centre

one-way system .....  
 shopping centre .....  
 high-street shops .....  
 multi-storey .....  
 car park .....  
 petrol station /  
 garage .....  
 pedestrian precinct .....  
 pedestrian street .....  
 zebra crossing .....  
 cycle lane .....  
 (advertising) .....  
 hoarding .....  
 taxi rank .....

## Roads in and around town

T-junction .....  
 crossroads .....  
 traffic lights .....  
 side road .....  
 one-way street .....

## Street features

1 lamp post .....  
 2 parking meter .....  
 3 recycling bins .....  
 4 pavement .....  
 5 litter bin .....  
 6 parking bay .....  
 7 kerb .....  
 8 bench .....  
 9 public toilets .....  
 10 bus stop .....

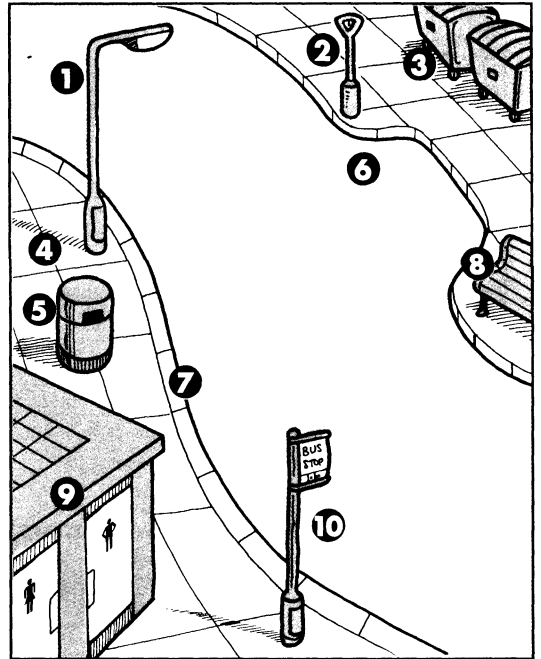

dead end /  
 cul-de-sac .....  
 roundabout .....  
 underpass .....  
 bypass .....  
 ring road .....

## Describing town and country living

urban environment .....

rural environment .....

suburban area .....

### Positive adjectives

quiet .....

peaceful .....

clean .....

relaxing .....

safe .....

magnificent .....

attractive .....

exciting .....

lively .....

modern .....

historic .....

multi-cultural .....

### Problems

vandalism .....

overcrowding .....

graffiti .....

pollution .....

traffic jams .....

### Negative adjectives

noisy .....

dirty .....

grimy .....

ugly .....

soulless .....

polluted .....

stressful .....

crowded .....

boring .....

dangerous .....

built-up .....

run-down .....

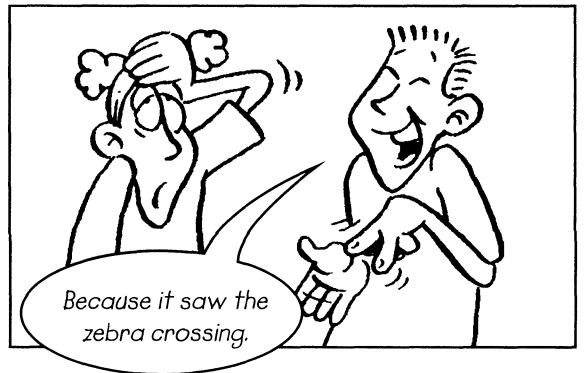
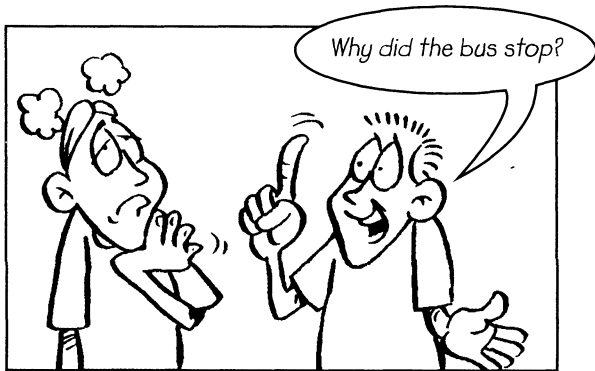

I live on the fifth floor of a 20-storey block of flats.

I live in the suburbs of ...

There's not much nightlife.

My area used to be quite run-down, but it's getting better.

My city's polluted and noisy, but there's lots to do.

**REF**

See also *Boost Your Vocabulary 2, Unit 2, House and home*, for types of house and phrases to describe location.



**REF**

See page 87 for the *British / American word list*.

1 Match the words in the columns to make compound nouns describing the built environment. Then tick the ones which are within two kilometres of your home.

1 town	superstore	1 <i>town centre</i> .....	<input type="checkbox"/>
2 office	tip	2 .....	<input type="checkbox"/>
3 tower	ground	3 .....	<input type="checkbox"/>
4 housing	site	4 .....	<input type="checkbox"/>
5 building	estate	5 .....	<input type="checkbox"/>
6 waste	centre	6 .....	<input type="checkbox"/>
7 industrial	block	7 .....	<input type="checkbox"/>
8 out-of-town		8 .....	<input type="checkbox"/>
9 rubbish		9 .....	<input type="checkbox"/>

2 Describe the environment your house / flat is in. You can use some of the compound nouns you have ticked in exercise 1.

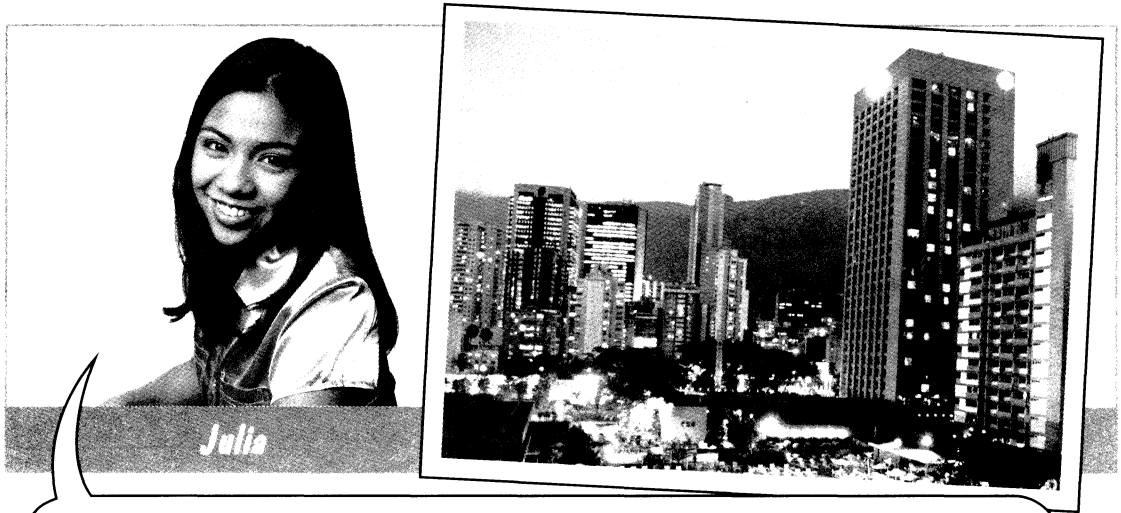

*Julia*

I live on the tenth floor of a tower block in Caracas. The view from the sitting room window is nice. You can see the modern office blocks and hotels in the city centre. But it's a pain when the lift isn't working! There's a shopping centre nearby, which is great for meeting your friends on a Saturday.

.....

.....

.....

.....

.....



3 Label the picture.

- 1 pedestrian
- precinct
- 2 a..... h.....
- 3 p..... s.....
- 4 t..... r.....
- 5 b..... s.....
- 6 m.....-s..... c..... p.....
- 7 l..... p.....
- 8 p..... t.....
- 9 z..... c.....
- 10 o..... w..... s.....
- 11 l..... b.....
- 12 t..... l.....
- 13 c..... l.....
- 14 p.....
- 15 b.....
- 16 r..... b.....
- 17 p..... m.....
- 18 p..... b.....

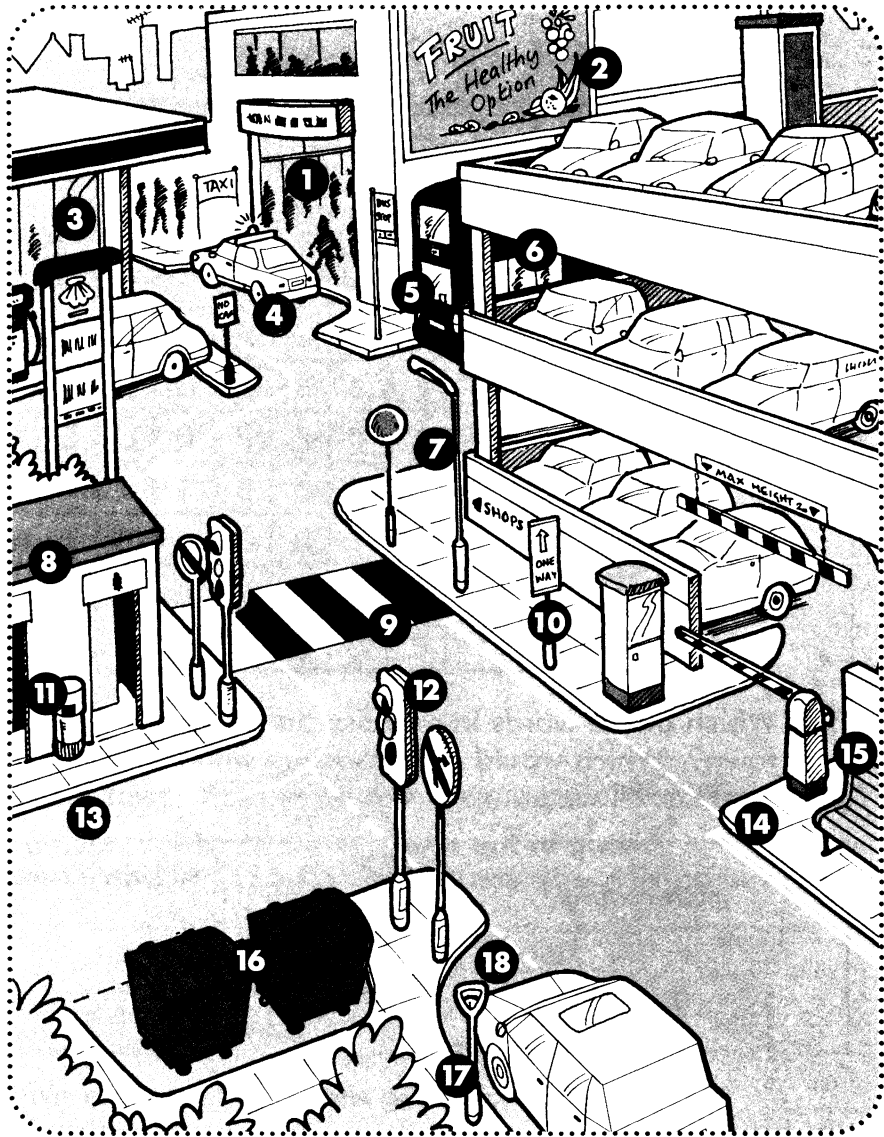

4 What do you call

- 1 a road which takes traffic around a town?
- 2 a tunnel under the road for pedestrians?
- 3 a street from which there is no exit?
- 4 the edge between the pavement and the road?
- 5 a ?
- 6 a ?
- 7 a ?

a ring road / a bypass

.....

.....

.....

.....

.....

.....

.....

abc 5a Circle 20 adjectives in the wordsearch.

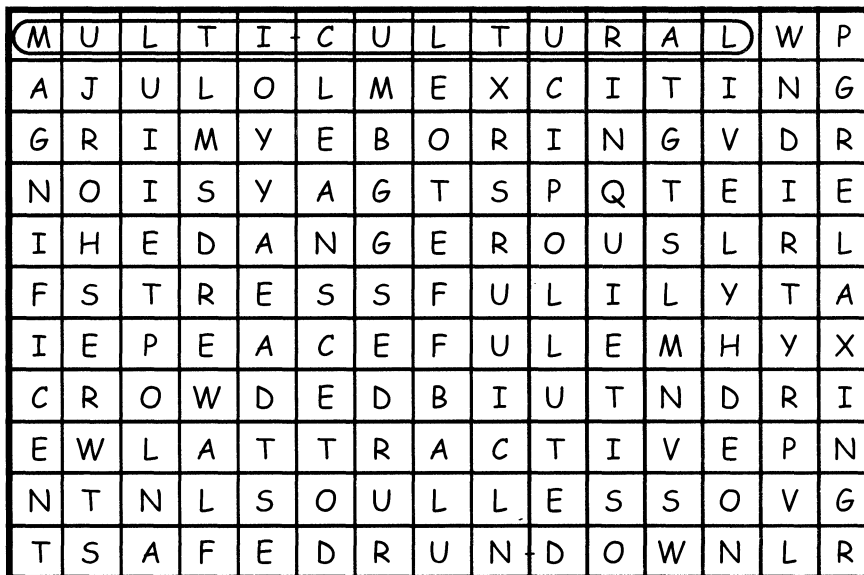

5b Which of the words in exercise 5a would you associate with living in the town? Which would you associate with living in the country?

**Living in the town**

*multi-cultural*

**Living in the country**

6 What are the advantages and disadvantages of living in a town? Choose from the adjectives in exercise 5 and the words and phrases in the box.

vandalism	overcrowding	graffiti	pollution	traffic jams
cultural life	nightlife	lots to do	nothing to do	

Advantages

*I like living / I'd like to live in the town because ...*

Disadvantages

*But ...*

**7a** Read what Tom says about his home city, Bradford, and fill in the chart.



Tom

I live in Bradford, which is in the north of England. It's not exactly Paris or Venice, but I like it all the same!

We've got the National Museum of Photography, one of the best museums in the country. And the artist David Hockney was born here. There's a Hockney gallery at Salt Mills, four miles north of the City.

The centre is quite polluted, but

there are some very attractive buildings, like the Alhambra Theatre, among all the grimy ones.

There are loads of ethnic shops and restaurants. The city is famous for its curries.

It has to be said, however, that the nightlife isn't great. If you're looking for a big night out, catch the train to Leeds!

The good things about living in Bradford	The bad things about living in Bradford
<i>the National Museum of Photography</i>	.....
.....	.....
.....	.....
.....	.....
.....	.....



**7b** Make a chart for your own town. Then write a description similar to Tom's.

The good things about living in	The bad things about living in
.....	.....
.....	.....
.....	.....



**8** Write ten words and five expressions you are going to memorize.

Words	Expressions
1 .....	1 .....
2 .....	.....
3 .....	2 .....
4 .....	.....
5 .....	3 .....
6 .....	.....
7 .....	4 .....
8 .....	.....
9 .....	5 .....
10 .....	.....

# 12 Holidays, celebrations and festivals

Translate the words and phrases.

## Public holidays in the UK

- Christmas .....
- Easter .....
- New Year's Day .....
- bank holiday .....

*Bank holidays are days when most businesses are closed. They almost always occur on a Monday.*

## Birthdays

- birthday .....
- birthday party .....
- birthday cake .....
- birthday card .....
- birthday present .....
- give flowers / a box .....
- of chocolates .....

## Parties

- invitation .....
- party games .....
- decorations .....
- music .....
- dancing .....

## Decorations

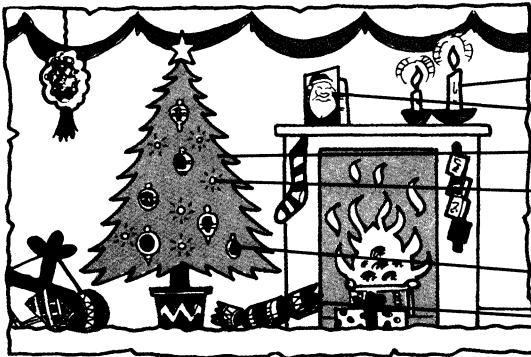

- streamer .....
- candle .....
- Christmas card .....
- Christmas tree .....
- lights .....
- Christmas decoration .....
- cracker .....

## Special clothes and make-up

- costume .....
- mask .....
- wig .....

- get ready (to go out) .....
- dress up (as Joan of Arc) .....
- wear a (pirate's) costume .....
- wear fancy dress .....
- wear make-up .....
- have your face painted .....



## Christmas

Christmas Eve .....  
 Father Christmas /  
 Santa Claus .....  
 Christmas Day .....  
 turkey .....  
 Christmas pudding .....  
 Boxing Day .....  
 New Year's Eve .....  
 New Year's Day .....

'Christmas' is sometimes shortened to 'Xmas'.

## Easter

Lent ..... He's given up chocolate  
 for Lent.  
 .....  
 Shrove Tuesday ..... pancake day  
 .....  
 Good Friday ..... hot cross buns  
 .....  
 Easter Sunday ..... chocolate Easter egg  
 .....

## Special days celebrated in the UK

### April Fool's Day

play a trick on someone  
 .....

### Valentine's Day

send someone a card (anonymously)  
 .....

decorate a card with love hearts  
 .....

### Mother's Day / Father's Day



We had | a party.  
 | a barbecue.  
 | a (family) get-together.

I sent him an invitation.

I replied to her invitation.

Thank you for your invitation.

I'd be delighted to come to  
 your party. / I'm sorry I won't  
 be able to come.

### Hallowe'en

dress up as a witch / a ghost  
 .....

make a Hallowe'en lantern out of a  
 pumpkin  
 .....

'trick or treat'  
 .....

### Guy Fawkes Night

make a guy  
 .....

have a bonfire party  
 .....

set off fireworks  
 .....

REF

See page 85 for the dates of festivals and special days.

REF



See page 87 for the British / American word list.



1 Write an e-mail to Gemma's mum accepting her invitation.

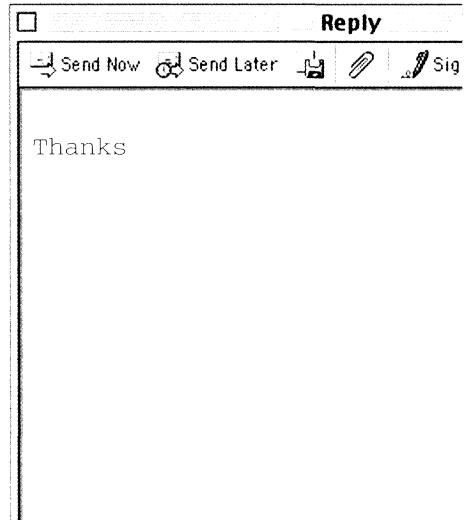

2 You're at Gemma's party. Label the picture.

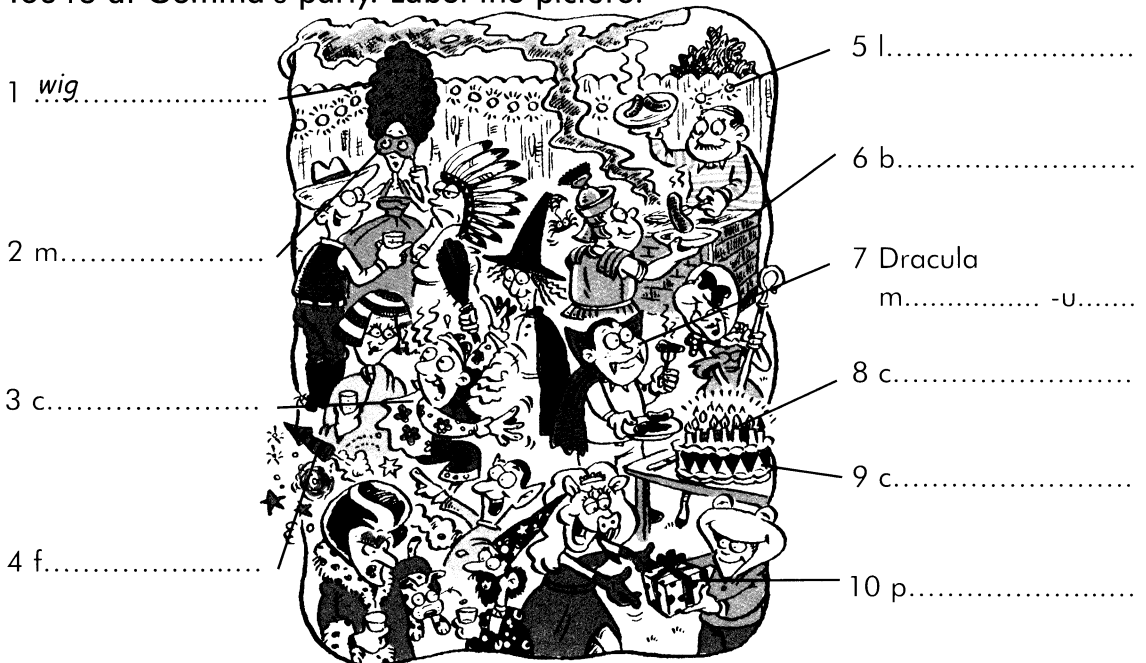

3 Describe Gemma's party, or a party you have been to, in a letter to a friend. Use the words in exercise 2 and some of the words and phrases in the box.

- |                    |                 |                  |       |
|--------------------|-----------------|------------------|-------|
| have a good time   | have fun        | have a laugh     | dance |
| wear a ... costume | dress up as ... | play party games | music |

*I've just been to the most fantastic party. ...*

4 How did you celebrate your birthday / name day when you were a child?  
 How do you celebrate them now?  
 Read what Ben says, then write your own account.

<p>When I was at primary school, we used to sing 'Happy Birthday' when it was someone's birthday. I sometimes had a party at home, with a cake and candles. And we</p>	<p>played party games, like 'Musical chairs'.          Now, I go out with friends to the cinema or to a disco.</p>
--	--

.....

.....

.....

.....

5 Try this quick quiz.

# Quick Quiz

**1 With which day do you associate**

- |                                   |                    |
|-----------------------------------|--------------------|
| a) hot cross buns?                | Hallowe'en         |
| b) chocolate eggs?                | <b>Good Friday</b> |
| c) lanterns made out of pumpkins? | Christmas          |
| d) pancakes?                      | Guy Fawkes         |
| e) a decorated tree?              | Easter             |
| f) fireworks?                     | Shrove Tuesday     |

**2 What do you call**

- |  |                  |
|--|------------------|
| a) the period just before Easter?                            | New Year's Eve   |
| b) the day when Americans celebrate the creation of the USA? | Bank Holiday     |
| c) the famous carnival in Rio de Janeiro?                    | New Year's Day   |
| d) the last day of the year?                                 | <b>Lent</b>      |
| e) the first day of the year?                                | Mardi Gras       |
| f) the day when people who work have a holiday?              | Independence Day |

**3 Do you know the dates of**

- |                      |                                      |
|----------------------|--------------------------------------|
| a) Guy Fawkes Night? | <i>5<sup>th</sup> November</i> ..... |
| b) Hallowe'en?       | .....                                |
| c) Christmas Day?    | .....                                |
| d) New Year's Day?   | .....                                |
| e) Independence Day? | .....                                |

Check your answers on page G of the Answer key.



6a Complete the descriptions. Then say which day / night is being celebrated.

1

We dressed up as  <sup>1</sup> *witches* ..... and after dark we went round to all our neighbours' houses. When they opened the door we shouted, <sup>2</sup> '..... or <sup>3</sup> .....







Day / Night: .....

2

I sent him a  <sup>1</sup> ..... with a big  <sup>2</sup> ..... on it. I sent it  <sup>3</sup> ....., of course. But I hope he guesses it's from me!

Day / Night: .....

3

We opened our  <sup>1</sup> ..... in the morning and had a traditional dinner of  <sup>2</sup> ..... and  <sup>3</sup> ..... The  <sup>4</sup> ..... looked lovely, with all the  <sup>5</sup> ..... and the  <sup>6</sup> ..... After dinner, we pulled  <sup>7</sup> ..... and watched a film on TV.

Day / Night: .....

4

We told Kirsty that our English teacher, Mr Jackson, had got married at the weekend and we'd bought him some  <sup>1</sup> ..... We asked her to give them to him at the beginning of the lesson. So she did. 'Congratulations on getting married, Mr Jackson!' she said. He looked puzzled. Then he smiled. 'Kirsty,' he said, 'I think someone's played a <sup>2</sup> ..... on you!'

Day / Night: .....



6b Describe a special day, like one of those above, from your own experience.



7a Read about The Day of the Tomato. Then write a similar paragraph about Mardi Gras.

Festival	La Tomatina (The Day of the Tomato)	Mardi Gras (Carnival)
▶ where?	Buñol, near Valencia, Spain	Rio de Janeiro, Brazil
▶ when?	August	February
▶ how long?	A day	Five nights and four days
▶ how many people?	About 20,000	Hundreds of thousands
▶ what happens?	People throw tomatoes at each other – the fruitiest fiesta in the world!	People dress up in fantastic costumes – dance the samba – street parties – the biggest carnival of them all!

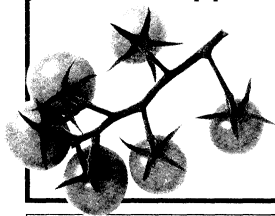

*The Day of the Tomato takes place in Buñol, near Valencia in Spain, in August. It lasts for a day and it attracts about*

*20,000 people. They spend the whole day throwing tomatoes at each other. It's the fruitiest fiesta in the world!*



7b Complete the chart about a special day in your country, or one you know about. Then use the information to write a paragraph.

Festival	.....
▶ where?	.....
▶ when?	.....
▶ how long?	.....
▶ how many people?	.....
▶ what happens?	.....

**Carnival** (Cadiz, Spain)

**INDEPENDENCE DAY, USA**

**CHINESE NEW YEAR**

*Diwali*  
(the Hindu Festival of Lights)



8 Write ten words and five expressions you are going to memorize.

Words	Expressions
1 .....	1 .....
2 .....	.....
3 .....	2 .....
4 .....	.....
5 .....	3 .....
6 .....	.....
7 .....	4 .....
8 .....	.....
9 .....	5 .....
10 .....	.....

# Test yourself 3 (Units 5 to 8)

How much can you remember?

My mark:           
60

1 Describe these objects using shape adjectives.

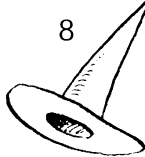
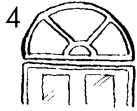
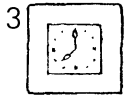
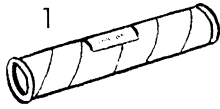
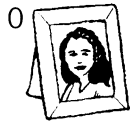

- 0 a *rectangular*..... photo frame  
 1 a ..... poster tube  
 2 a ..... road sign  
 3 a ..... clock  
 4 a ..... window  
 5 a ..... chocolate  
 6 a ..... tray  
 7 a watch with an ..... face  
 8 a ..... hat  
 9 a ..... bottle  
 10 a ..... top

(10 marks)

2 Complete the description of this vase.

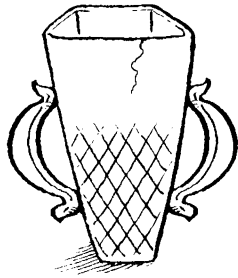

It's a <sup>0</sup> *glass*..... vase with a diamond <sup>1</sup> .....  
 on it. The top is square with <sup>2</sup> ..... corners. It's  
 not quite perfect because it's got a <sup>3</sup> ..... in it.  
 The <sup>4</sup> ..... are crescent-shaped. It <sup>5</sup> .....  
 about 25cm by 10cm.

(5 marks)

3 Which of these words do you associate with the countryside? Which of them do you associate with the town?

a cattle grid	a tower block	air pollution
a field	a track	corn
a one-way system	a traffic jam	mud
a pedestrian precinct	a valley	

Countryside	Town
0 <i>a cattle grid</i> .....	6 .....
1 .....	7 .....
2 .....	8 .....
3 .....	9 .....
4 .....	10 .....
5 .....	

(10 marks)

**4 You find each of these in a town. What are they?**

- 0 You put unwanted newspapers and bottles in them. *recycling bins* .....
- 1 You put rubbish into it. ....
- 2 You wait here for a bus. ....
- 3 It's black and white and it's the best place to cross the road. ....
- 4 You leave your car next to it and put money into it. ....
- 5 When they're red, you must stop; when they're green you can go. ....

(5 marks)

**5 Complete the adjectives. Then write the opposite for each one.**

It was a <sup>0</sup> n o i s y place, on the edge of the town. The buildings were <sup>1</sup> u \_ \_ y, the air was <sup>2</sup> p o l \_ \_ \_ e d and life was <sup>3</sup> s t r \_ \_ \_ f u l for the people who lived there. The streets were <sup>4</sup> d a n \_ \_ \_ o u s at night. And yet it was a <sup>5</sup> l i \_ \_ l y place.

- 0 *quiet* .....
- 1 .....
- 2 .....
- 3 .....
- 4 .....
- 5 .....

(10 marks)

**6 Label the parts of the tree and the flower.**

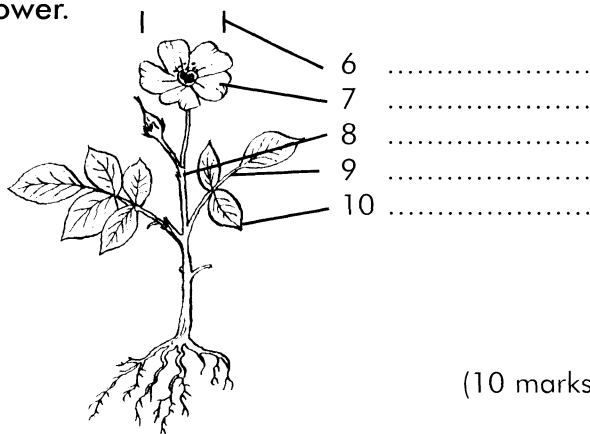
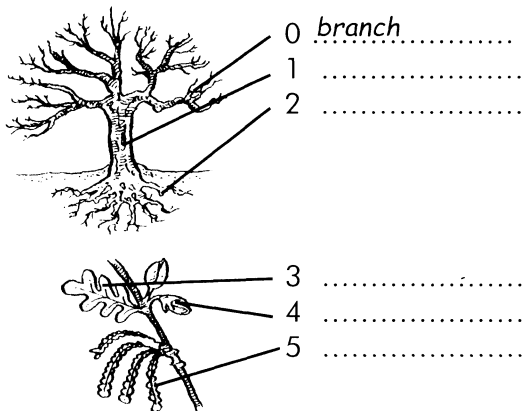

(10 marks)

**7 What are typical things to do on these days?**

Valentine's Day	0	<i>decorate a card</i> .....	with love hearts
	1	.....	anonymously
your birthday	2	.....	a party
April Fool's Day	3	play .....	on someone
Hallowe'en	4	.....	as a witch or a ghost
	5	make .....	out of a pumpkin
	6	play '.....'	or treat'
Guy Fawkes Night	7	.....	a guy
	8	have a .....	
	9	.....	fireworks
Mother's Day	10	.....	to your mother

(10 marks)

# Reference



## Adjectives followed by prepositions

See Unit 1, *People*, page 6.

The choice of preposition can depend on structure and meaning. Here are some examples of the adjectives in Unit 1 followed by prepositions.

What are you *angry about*?

Are you *angry with* me?

I'm *disappointed about* not being able to go on holiday.

I'm *disappointed in* you. You cheated in the exam.

I'm *disappointed with* my results.

I'm *disgusted at / by / with* his behaviour. I never want to see him again.

I'm *embarrassed about* behaving so badly. I'm sorry.

I'm *embarrassed by* my mistakes in English.

I'm *excited about* our trip to Canada. It'll be fantastic!

I'm *excited by* the idea of skating on frozen lakes.

I'm *excited at* the thought of meeting my Canadian cousins for the first time.

I'm *exhausted by / from* working so late at night.

I'm *frustrated by* not having my computer with me.

I'm *frustrated with* him for taking so long to do the job.

I'm *happy about* moving to London. It'll be great.

I'm *happy for* you. You've done well.

I'm *happy with* my room, now that I've painted it orange.

I'm *sad about* the death of my dog. I miss him.

I feel *sad for* David. He's been so unlucky.

I was *shocked at / by* his rudeness.

I'm *sorry about* the mess.

I feel *sorry for* him. He's done nothing wrong, yet everybody blames him.

I was *surprised at / by* your reaction. Why did you start crying?

I was *upset about / at / over* not hearing from Marie for two weeks.

I was *upset with* Marie because she didn't phone me.

## Transitive and intransitive verbs

See Units 2, 3 and 5.

Transitive verbs are verbs which take an object:



*I examined the jacket carefully.*

Intransitive verbs do not take an object:



*That rubbish bag stinks!*

Verbs can be both transitive and intransitive:

*Be quiet! I can't hear.* (intransitive)

*I can't hear the music.* (transitive)

## Units of measurement

See Unit 9, *Describing objects: shapes and material*, page 59.

### Area

square metres

$4^2$  – 'four squared'

$4\text{m}^2$  – 'four square metres'

### Volume

cubic metres

$4^3$  – 'four cubed'

$4\text{m}^3$  – 'four cubic metres'

## Dates of festivals and special days celebrated in the UK

See Unit 12, *Holidays, celebrations and festivals*, page 77.

Christmas Eve	24 <sup>th</sup> December	April Fool's Day	1 <sup>st</sup> April
Christmas Day	25 <sup>th</sup> December	Valentine's Day	14 <sup>th</sup> February
Boxing Day	26 <sup>th</sup> December	Hallowe'en	31 <sup>st</sup> October
New Year's Eve	31 <sup>st</sup> December	Guy Fawkes Night	5 <sup>th</sup> November
New Year's Day	1 <sup>st</sup> January		

## Spelling rules

REF

See also *Boost Your Vocabulary 1 and 2*, page 85, for Some basic spelling rules.

## Comparatives and superlatives of two-syllable adjectives

Two-syllable adjectives which end in *-y*, *-ow*, *-le* and *-er* usually take *-er* in the comparative and *-est* in the superlative.

Remember that *y* changes to *i* before *-er* and *-est*, and that if the adjective already ends in *-e*, you just add *r* and *st*.

	<b>comparative</b>	<b>superlative</b>
funny	funnier	funniest
narrow	narrower	narrowest
simple	simpler	simplest
clever	cleverer	cleverest

For other two-syllable adjectives, use *more* and *most*:

afraid	more afraid	(the) most afraid
patient	more patient	(the) most patient

You have to use *more* and *most* with some one-syllable adjectives, like *shocked* (*more shocked*, *the most shocked*), but there aren't many of them – fortunately!







British	American
<b>1 People</b>	
(See page 6.) angry (about, with) sensible mean, selfish unkind, cruel nasty, horrible cheeky	<i>also</i> mad (at) practical / reasonable selfish <i>also</i> mean <i>also</i> awful disrespectful, impolite
<b>2 The senses</b>	
(See page 12.) have / take a look Sorry, I can't hear you. stroke (an animal) I feel like having an early night. It smells horrible. Take the rubbish bag out. Stop sniffing!	take a look Excuse me. I can't hear you. pet (an animal) I feel like making it an early night. It smells awful / terrible. Take the garbage bag out. Stop sniffing!
<b>3 The body and actions</b>	
(See page 18.)	<i>no differences</i>
<b>4 Health</b>	
(See page 24.) I've got ... toothache backache earache flu diarrhoea sunburnt ill  I feel sick.  a mouth ulcer graze (your knee) have an injection I keep being sick. a tablet Put a plaster on it.	I have ... a toothache a backache an earache the flu sp. diarrhea sp. sunburned sick ( <i>ill</i> usually for serious diseases) I feel sick to my stomach / nauseous. a canker sore skin (your knee) have / get a shot I keep throwing up. a pill Put a bandaid on it.

British	American
<b>5 Sport</b>	
(See page 32.) canoe (with one paddle) football shuttlecock racing car (ski) sticks air cylinder windsurfer pitch (baseball, football, field hockey) circuit piste pitch (volleyball) 1-0 (one / nil) 1-1 (a draw / one all) We drew.	kayak soccer shuttlecock / birdie race car poles (air) tank sailboard field track ski run court 1-0 (one to nothing) 1-1 (a tie / one, one / a draw) We tied.
<b>6 Education and jobs</b>	
(See page 38.) staff member of staff head of department  deputy head headteacher lesson class (meaning <i>form</i> ) marks revision I'm revising for my exams at the moment. My father left school at 16.  mark (e.g. 17/20) I took / sat / did an exam. I retook Maths. go to university / college get a place at (Oxford) read (= study) (Geography) go to lectures / seminars / tutorials do (Music) graduate (noun)	faculty member of the faculty head of the (English) department vice-principal principal class grade grades study / review I'm studying for my exams right now.  My father graduated (from high school) when he was 16. score I took an exam.  I repeated math. go to college (even if a university) get into (Oxford)  major in (Geography)  go to classes / lectures / seminars study (music) = master's or Ph.D. student

British	American
postgraduate the film industry set up my own business open a shop a policeman / policewoman qualifications You need to have qualifications in (...).	= postdoctoral the movie industry start my own business open a store a police officer  diploma You need a high school diploma.

### 7 Computers

(See page 44.) My computer's crashed. I've lost work. switch on / off	My computer crashed.  I lost work. turn on / off
---	---

### 8 Music and drama

(See page 50.) show (= Let's go to a show.) theatre pantomime  practise  circle balcony gallery interval first night	the theater  sp. theater <i>not an equivalent in AmE</i> practice (verb and noun) first (lower) balcony mezzanine /dress circle second (upper) balcony intermission opening night
--	---

### 9 Describing objects: shapes and materials

(See page 58.) aluminium perspex	sp. aluminum plexiglass
--	----------------------------

### 10 In the countryside

(See page 64.) track  footpath signpost cattle grid maize	path (for walking) / dirt road (for cars) trail street sign / signpost cattle guard corn
---	---

British	American
<b>11 In the town</b>	
(See page 70.) town centre office block tower block housing estate waste ground industrial estate rubbish tip shopping centre  high-street shops multi-storey car park petrol station pedestrian precinct zebra crossing cycle lane (advertising) hoarding litter bin  parking bay pavement kerb public toilets traffic lights  roundabout  ring road I live on the fifth floor of a 20-storey block of flats.	downtown office building high-rise building subdivision wasteland industrial park garbage dump sp. shopping center / (shopping) mall downtown stores parking garage gas station pedestrian mall crosswalk bicycle lane billboard trash container / litter basket parking space sidewalk sp. curb pubic restrooms stop lights / traffic signals traffic circle / rotary (New England) beltway I live on the sixth floor of a 20-story apartment building.

### 12 Holidays, celebrations and festivals

(See page 76.) bank holiday cracker  wear fancy dress Father Christmas / Santa Claus Christmas pudding  Boxing Day  make a Hallowe'en lantern Guy Fawkes Night / make a guy / have a bonfire party	legal holiday <i>not an equivalent in AmE</i> wear a costume Santa Claus / Santa  <i>not an equivalent in AmE</i> <i>not an equivalent in AmE</i> make a jack-o'- lantern <i>not an equivalent in AmE</i>
---	--

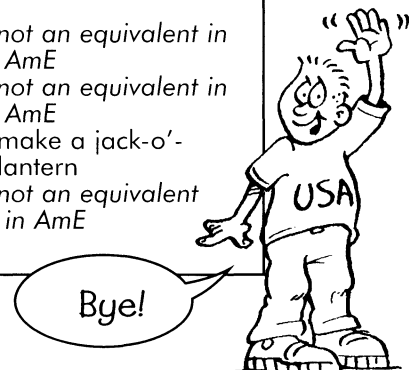

# Self assessment and progress check

## Self assessment

Fill in the chart when you have completed each unit.

	Which vocabulary sections were the most useful? (e.g. <i>Character</i> )	How well did you do in the exercises? very   quite   not so well 	You wrote down some words and expressions to memorize. How many of them can you remember? Words /10 Expressions /5	Which vocabulary sections do you need to go over again before you do the test?
1	People			
2	The senses			
3	The body and actions			
4	House and home			

Test score: / 60

5	Sport			
6	Education and jobs			
7	Computers			
8	Music and drama			

Test score: / 60

9	Describing objects: shapes and materials			
10	In the countryside			
11	In the town			
12	Holidays, celebrations and festivals			

Test score: / 60

## Progress check

How much of the vocabulary did you know **before** you worked through the units?  
How much do you feel you know **after** working through the units?

		Less than 25%	About 50%	More than 60%
Units 1 – 4	before			
	after			
Units 5 – 8	before			
	after			
Units 9 – 12	before			
	after			

## References

- Clanchy, J. & Ballard, B. (1991) *Essay writing for students* (2nd ed.). Sydney: Longman Cheshire.
- Learning Centre, University of NSW. *Questions for the end of the day*.
- Learning Development, University of Wollongong. *Essay Writing: The process: The multi-faceted nature of essay writing*.
- Learning Development, University of Wollongong. *Essay Writing: The argument: Development and structure*.
- Learning Development, University of Wollongong. *Essay Writing: The mechanics of essay writing*.
- Learning Development, University of Wollongong. *Editing your assignments*.
- Learning Development, University of Wollongong. *Annotated models of disciplinary essays: Annotated philosophy essay*.
- Learning Development, University of Wollongong. *Annotated models of disciplinary essays: Annotated modern languages essay*.
- Learning Development, University of Wollongong. *Annotated models of disciplinary essays: Annotated sociology essay*.
- Learning Development, University of Wollongong. *Annotated models of disciplinary essays: Annotated engineering essay*. Learning Development, University of Wollongong.
- MacLean, P. *Essay Writing*. Learning Skills Unit, University of Melbourne.
- MacLean, P. *Essay Writing for Education Students*. Learning Skills Unit, University of Melbourne.
- MacLean, P. & Starkey, R. *Towards a critical review of the literature*. Learning Skills Unit, University of Melbourne.

Oshima, A. & Hogue, A. (1991) *Writing Academic English* (2nd Ed).  
California: Addison Wesley.

Woodward-Kron, R., Thomson, E. & Meek, J. (2000) *Academic Writing: a language based guide* (CD-ROM), University of Wollongong.

Best, M., Tucker, J., Oliver, N., Palmer, E., Lyne, S. and Neufeldt, A. 1995 (updated 10 November 2000, cited January 2001) *Essay Writing*. University of Victoria hypertext writer's guide.  
<http://www.clearcf.uvic.ca/writersguide/Pages/EssaysToc.html>

## References:

### Primary sources:

Adeeb, Imad, Hamed, Marwan. (2006). The Yacoubian Building. Good news Group, Arab Co for Cinema Production & Distribution.

Al Aswany, A. (2002). The Yacoubian Building . Madboly library .Egypt

### Secondary sources:

Babou, M. (2014). *A Sociolinguistic Analysis of Use and Perception of Insults: Tlemcen Speech Community*. 1(1), 29–39

Batistella, E.L. (2005). *Bad Language: Are Some Words Better Than Others?*. New York: Oxford University Press.

Choliludin. (2005). *The Technique of Making Idiomatic Translation*. Jakarta: Kesain Blanc.

Doyle, T.M. (2006) . *Teaching "Bad language " in a serious and systematic manner* . Proceedings of the CATESOL state conference. .  
[www.catesol.org/06Doyle.pdf](http://www.catesol.org/06Doyle.pdf)

Jay , Timothy. ( 1996 ). *What to Do When your Students Talk Dirty ?* San Jose Resource Publications ,Inc.

Jay, T. (1992). "Cursing in America". Philadelphia: John Benjamins Publishing. Jay, T. 1996. "What to do when your students talk dirty". University of Virginia: Resource Publication.

Jay, Timothy.(1992). Cursing in America: A Psychological Study of Dirty Language in The Courts, in The Schoolyards and on The Street. Illustrate. John Benjamins Publishing.

Mazid, Bahaa-Eddin, M. (2008). The Politeness Principle: From Grice to Netiquette. Annals of Arts and Social Sciences (AASS). Kuwait University: Academic Publication Council.

Mbaya, N. (2002). Linguistic Taboo in African Marriage Context: A Study of Oromo Laguu. Nordic Journal of African Studies. 11(2), 224-235.

Liedlich, Raymond D.( 1973). Coming to Terms with Language: An Anthology. edited by R. D. Liedlich. New York: John Wiley & Sons, Inc.

Wardhaugh, R.( 2006). An Introduction to Sociolinguistics (Fifth Edition). Oxford:Blackwell Publishing Ltd.