



South Valley University



Faculty of Science, Qena

Physics Department

Radiation and Radiation protection

By

Prof. Dr. Shaban Harb

2023-2022

1. Structure of Matter

1.1. Matter and Energy

The existence of the universe is explained by two entities: matter and energy. These two entities are interchangeable and exist in different forms to make up all things visible or invisible in the universe. Whereas matter has a definite size, shape, and form, energy has different forms but no size and shape.

Matter is characterized by its quantity, called the *mass*, and is composed of the smallest unit, the atom. In atomic physics, the unit of mass is the atomic mass unit (amu), which is equal to 1.66×10^{-27} kg.

Energy is the capacity to do work and can exist in several forms: kinetic energy (which is due to the motion of matter); potential energy (which is due to the position and configuration of matter); thermal energy (which is due to the motion of atoms or molecules in matter); electrical energy (which is due to the flow of electrons across an electric potential); chemical energy (which is due to chemical reaction); and radiation (energy in motion). Energy can change from one form to another. Of all these forms, radiation is of great importance in nuclear medicine and, therefore, will be discussed in detail.

Mass and energy are interchangeable, and one is created at the expense of the other. This is predicted by the Einstein's mass–energy relationship:

$$E = mc^2 \quad (1.1)$$

where E is energy in ergs, m is the mass in grams, and c is the velocity of light in a vacuum given as 3×10^{10} cm/sec. This relationship states that every-thing around us can be classified as matter or energy.

1.1.1. Radiation

Radiation is a form of energy in motion through space. It is emitted by one object and absorbed or scattered by another. Radiations are of two types:

1. **Particulate radiations:** Examples of these radiations are energetic electrons, protons, neutrons, β -particles, and so forth. They have mass and charge, except neutrons, which are neutral particles. The velocity of their motion depends on their kinetic energy. The particulate radiations originate from radioactive decay, cosmic rays, nuclear reactions, and so forth.

2. **Electromagnetic radiations:** These radiations are a form of energy in motion that does not have mass and charge and can propagate as either waves or discrete packets of energy, called the *photons* or *quanta*. These radiations travel with the velocity of light. Various examples of electromagnetic radiations include radio waves, visible light, heat waves, γ -radiations, and so forth, and they differ from each other in wavelength and hence in energy. Note that the sound waves are not electromagnetic radiations. The energy E of an electromagnetic radiation is given by

$$E = h\nu = \frac{hc}{\lambda} \quad (1.2)$$

where h is the Planck constant given as 6.625×10^{-27} erg · s/cycle, ν is the frequency in hertz (Hz), defined as 1 cycle per second, λ is the wavelength in centimeters, and c is the velocity of light in vacuum, which is equal to nearly 3×10^{10} cm/s.

The energy of an electromagnetic radiation is given in electron volts (eV), which is defined as the energy acquired by an electron when accelerated through a potential difference of 1 volt. Using $1 \text{ eV} = 1.602 \times 10^{-12}$ erg, Eq. (1.2) becomes

$$E(\text{eV}) = \frac{1.24 \times 10^{-4}}{\lambda} \quad (1.3)$$

where λ is given in centimeters. Table 1.1 lists the different electromagnetic radiations along with their frequencies and wavelengths.

Table 1.1. Characteristics of different electromagnetic radiations.

Type	Energy (eV)	Frequency (Hz)	Wavelength(cm)
Radio, TV	10^{-10} – 10^{-6}	10^4 – 10^8	10^2 – 10^6
Microwave	10^{-6} – 10^{-2}	10^8 – 10^{12}	10^{-2} – 10^2
Infrared	10^{-2} –1	10^{12} – 10^{14}	10^{-4} – 10^{-2}
Visible	1–2	10^{14} – 10^{15}	10^{-5} – 10^{-4}
Ultraviolet	2–100	10^{15} – 10^{16}	10^{-6} – 10^{-5}
x-Rays and γ -rays	100 – 10^7	10^{16} – 10^{21}	10^{-11} – 10^{-6}

Table 1.2. Characteristics of electrons and nucleons

Particle	Charge	Mass (amu)*	Mass (kg)	energy (MeV) [†]
Electron	–1	0.000549	9.108×10^{-31}	0.511
Proton	+1	1.00728	1.6721×10^{-27}	938.78
Neutron	0	1.00867	1.6744×10^{-27}	939.07

* amu = 1 atomic mass unit = 1.66×10^{-27} kg = 1/12 of the mass of ^{12}C .

[†] 1 atomic mass unit = 931 MeV.

1.1.2. The Atom

The atom can be considered as the smallest unit in the composition of matter. The atom is composed of a nucleus at the center and one or more electrons orbiting around the nucleus. The nucleus consists of protons and neutrons, collectively called *nucleons*. The protons are positively charged particles with a mass of 1.00728 amu, and the neutrons are electrically neutral particles with a mass of 1.00867 amu. The electrons are negatively charged particles with a mass of 0.000549 amu. The protons and neutrons are about 1836 times heavier than the electrons but the neutron is heavier than the proton by one electron mass (i.e., by 0.511 MeV). The number of electrons is equal to the number of protons, thus resulting in a neutral atom of an element. The characteristics of these particles are given in Table 1.2. The size of the atom is

about 10^{-8} cm (called the angstrom, Å), whereas the nucleus has the size of 10^{-13} cm (termed the fermi, F). The density of the nucleus is of the order of 10^{14} g/cm³. The electronic arrangement determines the chemical properties of an element, whereas the nuclear structure dictates the stability and radioactive transformation of the atom.

1.1.3. Electronic Structure of the Atom

The Bohr's atomic theory states (1913) that electrons rotate around the nucleus in discrete energy shells that are stationary and arranged in increasing order of energy. These shells are designated as the *K* shell, *L* shell, *M* shell, *N* shell, and so forth. When an electron jumps from the upper shell to the lower shell, the difference in energy between the two shells appears as electromagnetic radiations or photons. When an electron is raised from the lower shell to the upper shell, the energy difference is absorbed and must be supplied for the process to occur.

The detailed description of the Bohr's atomic structure is provided by the quantum theory in physics. According to this theory, each shell is designated by a quantum number n , called the *principal quantum number*, and denoted by integers, for example, 1 for the *K* shell, 2 for the *L* shell, 3 for the *M* shell, 4 for the *N* shell, and 5 for the *O* shell. Each energy shell is subdivided into subshells or orbitals, which are designated as *s*, *p*, *d*, *f*, and so on. For a principal quantum number n , there are n orbitals in a given shell. These orbitals are assigned the *azimuthal quantum numbers*, l , which represent the electron's angular momentum and can assume numerical values of $l = 0, 1, 2 \dots n - 1$. Thus for the *s* orbital, $l = 0$; the *p* orbital, $l = 1$; the *d* orbital, $l = 2$; the *f* orbital, $l = 3$; and so forth. According to this description, the *K* shell has one orbital, designated as $1s$, the *L* shell has two orbitals, designated as $2s$ and $2p$, and so forth. The orientation of the electron's magnetic moment in a magnetic field is described by the *magnetic quantum number*, m . The values of m can be $m = -l, -(l - 1), \dots, 0, \dots, (l - 1), l$. Each electron rotates about its own axis

clockwise or anticlockwise, and the *spin quantum number*, s ($s = -1/2$ or $+1/2$) is assigned to each electron to specify this rotation.

The electron configuration of the atoms of different elements is governed by the following rules:

1. No two electrons can have the same values for all four quantum numbers in a given atom.
2. The orbital of the lowest energy will be filled in first, followed by the next higher energy orbital. The relative energies of the orbitals are $1s < 2s < 2p < 3s < 3p < 4s < 3d < 4p < 5s < 4d < 5p < 6s < 4f < 5d < 6p < 7s$. This order of energy is valid for lighter elements and is somewhat different in heavier elements.
3. There can be a maximum of $2(2l + 1)$ electrons in each orbital.
4. For given values of n and l , each of the available orbitals is first singly occupied such that no electron pairing occurs. Only when all orbitals are singly occupied does electron pairing take place.
5. Each energy shell contains a maximum of $2n^2$ electrons.

The hydrogen atom has one proton in the nucleus and one electron in the orbit. Its electronic structure is represented as $1s^1$. The helium atom has two electrons, which are accommodated in the $1s$ orbital, and thus has the structure of $1s^2$. Now let us consider the structure of ^{16}O , which has eight electrons. The first two electrons will fill the $1s$ orbital. The next two electrons will go to the $2s$ orbital. There are three p orbitals, designated as p_x , p_y , p_z , which will be occupied by three electrons individually. The eighth electron will occupy the p_x orbital pairing with the electron already in it. Thus, the electronic configuration of ^{16}O is given by $1s^2 2s^2 2p^4$.

The electron configurations in different orbitals and shells are illustrated in Table 1.3, and the structure of ^{28}Ni is shown in Figure 1.1.

The electronic structure of the atom characterizes the chemical properties of elements. The outermost shell is the most stable and chemically inert

elements such as neon, argon, krypton, and xenon has the electronic structure of ns^2np^6 . Helium, although a noble gas, has the $1s^2$ configuration.

Table 1.3. Electron configurations in different energy shells.

Principal shell	Principal quantum number	Orbital (l)	No. of electrons = $2(2l + 1)$	$2n^2$
<i>K</i>	1	$s(0)$	2	2
<i>L</i>	2	$s(0)$	2	8
		$p(1)$	6	
<i>M</i>	3	$s(0)$	2	18
		$p(1)$	6	
		$d(2)$	1	
<i>N</i>	4	$s(0)$	2	32
		$p(1)$	6	
		$d(2)$	1	
		$f(3)$	1	
	5	$s(0)$	2	50
		$p(1)$	6	
		$d(2)$	1	
		$f(3)$	1	
		$g(4)$	1	

Elements having electronic configurations different from that of the noble gases either lose or gain electrons to achieve the structure ns^2np^6 of the nearest noble gas atom. The electrons in these shells are called the *valence electrons* and are primarily responsible for the chemical bond formation.

Electrons in different shells are held by *binding energy* in different shells of the atom. The binding energy of an electron is defined as the energy that is required to be supplied to remove it completely from a shell. The binding energy of the electron is the greatest in the *K* shell and decreases with higher shells such as *L*, *M*, and so on. The binding energy also increases with increasing atomic number of the elements. Thus, the *K*-shell binding energy (21.05 keV) of technetium, with atomic number 43, is higher than the *K*-shell binding energy (1.08 keV) of sodium, with atomic number 11. The *K*-shell binding energy of electrons in several elements are: carbon, 0.28 keV, gallium, 10.37 keV, technetium, 21.05 keV; indium, 27.93 keV; iodine,

33.16 keV; lead, 88.00 keV.

When an electron is removed completely from an atom, the process is called *ionization*. The atom is said to be ionized and becomes an ion. On

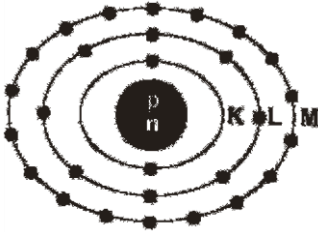

Fig. 1.1. The electronic configuration of ^{28}Ni . The *K* shell has 2 electrons, the *L* shell has 8 electrons, and the *M* shell has 18 electrons.

the other hand, when the electron is raised from a lower energy shell to an upper energy shell, the process is called *excitation*. Both ionization and excitation processes require a supply of energy from outside the atom such as heating, applying an electric field, and so forth. In the excited atoms, electrons jump from the upper energy shell to the lower energy shell to achieve stability. The difference in energy appears as electromagnetic radiations or photons. Thus, if the binding energy of *K*-shell electrons in, say, bromine is 13.5 keV and the *L*-shell binding energy is 1.8 keV, the transition of electrons from the *L* shell to the *K* shell will occur with the emission of 11.7 keV ($13.5 - 1.8 = 11.7$ keV) photons. As we shall see later, these radiations are called the *characteristic x-rays* of the product atom.

1.1.4. Patterns of nuclear stability

There are approximately 275 different nuclei which have shown no evidence of radioactive decay and, hence, are said to be stable with respect to radioactive decay. When these nuclei are compared for their constituent nucleons, we find that approximately 60 % of them have both an even number of protons and an even number of neutrons (even-even nuclei). The remaining 40% are about equally divided between those that have an even number of protons and an odd number of neutrons (even-odd nuclei) and those with an odd number of protons and an even number of neutrons (odd-even nuclei). There are only 5 stable nuclei known which have both an odd number of

protons and odd number of neutrons (odd-odd nuclei); ${}^2_1\text{H}$, ${}^6_3\text{Li}$, ${}^{10}_5\text{B}$ and ${}^{50}_{23}\text{V}$. It is significant that the first stable odd-odd nuclei are abundant in the very light elements.

The last nuclide is found in low isotopic abundance (0.25 %) and we cannot be certain that this nuclide is not unstable to radioactive decay with extremely long half-life.

Considering this pattern for the stable nuclei, we can conclude that nuclear stability is favored by even numbers of protons and neutrons. The validity of this statement can be confirmed further by considering for any particular element the number and types of stable isotopes; see Figure 3.1. Elements of even atomic number (i.e. even number of protons) are characterized by having a relatively sizable number of stable isotopes, usually 3 or more. For example, the element tin, atomic number 50, has 10 stable isotopes while cadmium ($Z = 48$) and tellurium ($Z = 52$) each have 8. By contrast silver ($Z = 47$) and antimony ($Z = 51$) each have only 2 stable isotopes, and rhodium ($Z = 45$), indium ($Z = 49$), and iodine ($Z = 53$) have only 1 stable isotope. Many other examples of the extra stabilization of even numbers of nucleons can be found from a detailed examination of Figure 3.1, or, easier, from nuclide charts, e.g. Appendix C. The guide lines of N and Z equal to 2, 8, 20, etc., have not been selected arbitrarily. These proton and neutron numbers represent unusually stable proton and neutron configurations. The curved line through the experimental points is calculated based on the liquid drop model of the nucleus which is discussed later in this chapter.

Elements of odd Z have none, one or two stable isotopes, and their stable isotopes have an even number of neutrons, except for the 5 odd-odd nuclei mentioned above. This is in contrast to the range of stable isotopes of even Z , which includes nuclei of both even and odd N , although the former outnumber the latter. Tin ($Z = 50$), for example, has 7 stable even-even isotopes and only 3 even-odd ones.

The greater number of stable nuclei with even numbers of protons and neutrons is explained in terms of the energy stabilization gained by combination of like nucleons to form pairs, i.e. protons with protons and neutrons with neutrons, but not protons with neutrons. If a nucleus has, for example, an even number of protons, all these protons can

exist in pairs. However, if the nucleus has an odd number of protons, at least one of these protons must exist in an unpaired state. The increase in stability resulting from complete pairing in elements of even Z is responsible for their ability to accommodate a greater range of neutron numbers as illustrated for the isotopes of germanium (^{32}Ge , 5 stable isotopes), relative to those of gallium (^{31}Ga , 2 stable isotopes), and arsenic (^{33}As , 1 stable isotope).

The same pairing stabilization holds true for neutrons so that an even-even nuclide which has all its nucleons, both neutrons and protons, paired represents a quite stable situation. In the elements in which the atomic number is even, if the neutron number is uneven, there is still some stability conferred through the proton-proton pairing. For elements of odd atomic number, unless there is stability due to an even neutron number (neutron-neutron pairing), the nuclei are radioactive with rare exceptions. We should also note that the number of stable nuclear species is approximately the same for even-odd and odd-even cases. The pairing of protons with protons and neutrons with neutrons must thus confer approximately equal degrees of stability to the nucleus.

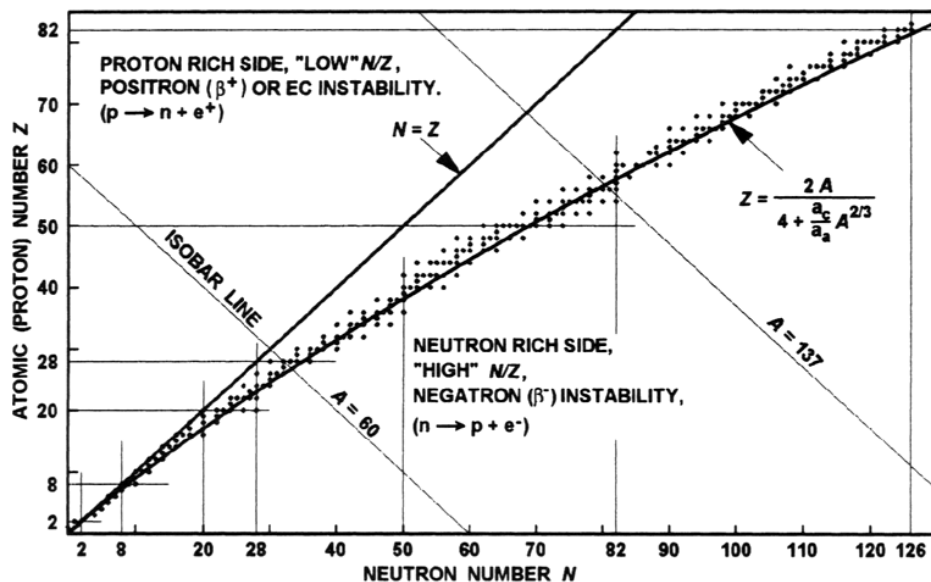
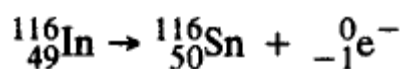

FIG. 1.2. Chart of stable nuclides as a function of their proton (Z) and neutron (N) numbers

1.1.5. Neutron to proton ratio

If a graph is made (Fig. 1.2) of the relation of the number of neutrons to the number of protons in the known stable nuclei, we find that in the light elements stability is achieved when the number of neutrons and protons are approximately equal ($N = Z$). However, with increasing atomic number of the element (i.e. along the Z -line), the ratio of neutrons to protons, the N/Z ratio, for nuclear stability increases from unity to approximately 1.5 at bismuth. Thus pairing of the nucleons is not a sufficient criterion for stability: a certain ratio N/Z must also exist. However, even this does not suffice for stability, because at high Z -values, a new mode of radioactive decay, α -emission, appears. Above bismuth the nuclides are all unstable to radioactive decay by α -particle emission, while some are unstable also to β -decay.

If a nucleus has a N/Z ratio too high for stability, it is said to be neutron-rich. It will undergo radioactive decay in such a manner that the neutron to proton ratio decreases to approach more closely the stable value. In such a case the nucleus must decrease the value of N and increase the value of Z , which can be done by conversion of a neutron to a proton. When such a conversion occurs within a nucleus, β^- (or negatron) emission is the consequence, with creation and emission of a negative β^- -particle designated by β^- or ${}_{-1}e^0$, For example:



At extreme N/Z ratios beyond the so called neutron drip-line, or for highly excited nuclei, neutron emission is an alternative to β^- decay.

If the N/Z ratio is too low for stability, then radioactive decay occurs in such a manner as to lower Z and increase N by conversion of a proton to neutron. This may be accomplished through positron emission, i.e. creation and emission of a positron (β^+ or ${}_{+1}e^0$) or by absorption by the nucleus of an orbital electron (electron capture, EC).

Examples of these reactions are:

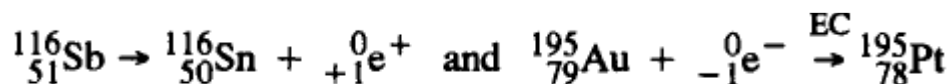

Positron emission and electron capture are competing processes with the probability of the latter increasing as the atomic number increases. Beta decay is properly used to designate all three processes, β^- , β^+ , and EC. (The term "beta decay" without any specification usually only refers to β^- - emission.)

Thus in the early part of the Periodic Table, unstable neutron deficient nuclides decay by positron emission, but for the elements in the platinum region and beyond, decay occurs predominantly by electron capture.

An alternative to positron decay (or EC) is proton emission, which, although rare, has



been observed in about 40 nuclei very far off the stability line. These nuclei all have half-lives < 1 min. For example:

We can understand why the N/Z ratio must increase with atomic number in order to have nuclear stability when we consider that the protons in the nucleus must experience a repulsive Coulomb force. The fact that stable nuclei exist means that there must be an attractive force tending to hold the neutrons and protons together. This attractive nuclear force must be sufficient in stable nuclei to overcome the disruptive Coulomb force.

Conversely, in unstable nuclei there is a net imbalance between the attractive nuclear force and the disruptive Coulomb force. As the number of protons increases, the total

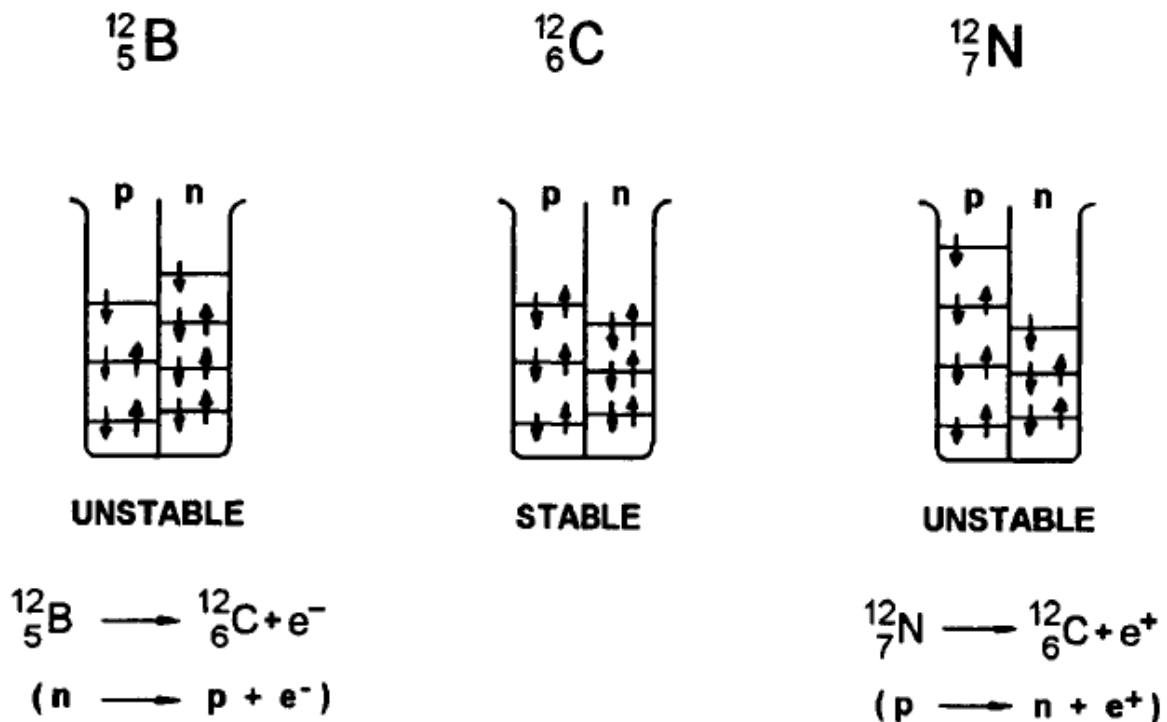

Fig. . The separation and pairing of nucleons in assumed energy levels within the isobar $A = 12$. Half-life for the unstable ${}^{12}\text{B}$ is 0.02 s, and for ${}^{12}\text{N}$ 0.01 s.

repulsive Coulomb force must increase. Therefore, to provide sufficient attractive force for stability the number of neutrons increases more rapidly than that of the protons. Neutrons and protons in nuclei are assumed to exist in separate nucleon orbitals just as electrons are in electron orbitals in atoms. If the number of neutrons is much larger than the number of protons, the neutron orbitals occupied extend to higher energies than the highest occupied proton orbital. As N/Z increases, a considerable energy difference can develop between the last (highest energy) neutron orbital filled and the last proton orbital filled. The stability of the nucleus can be enhanced when an odd neutron in the highest neutron orbital is transformed into a proton fitting into a vacant lower energy proton orbital; see the example for $A = 12$ in Figure 3.2.

1.1.6. Nuclear Binding Energy

According to the classical electrostatic theory, the nucleus of an atom cannot exist as a single entity, because of the electrostatic repulsive force among the protons in the nucleus. The stability of the nucleus is explained by the existence

of a strong binding force called the *nuclear force*, which overcomes the repulsive force of the protons. The nuclear force is effective equally among all nucleons and exists only in the nucleus, having no influence outside the nucleus. The short range of the nuclear force leads to a very small size ($\sim 10^{-13}$ cm) and very high density ($\sim 10^{14}$ g/cm³) of the nucleus.

The mass M of a nucleus is always less than the combined masses of the nucleons A in the nucleus. The difference in mass ($M - A$) is termed the *mass defect*, which has been used as binding energy for all nucleons in the nucleus. The average binding energy of a nucleon is equal to the total binding energy (calculated from the mass defect) divided by the number of nucleons. It is of the order of 6–9 MeV, although the binding energy of an individual nucleon has a definite value, depending on the shell it occupies. The binding energy of a nucleon must be supplied to completely remove it from the nucleus. Note that whereas the binding energy of the nucleons is in the megaelectron volt (MeV) range, the electron binding energy in the atomic orbital is of the order of kiloelectron volts (keV), a factor of 1000 lower.

1.1.7. Nuclear Nomenclature

A *nuclide* is an atomic species with a definite number of protons and neutrons arranged in a definite order in the nucleus.

Radionuclides are those nuclides that are unstable and thus decay by emission of particles or electromagnetic radiations or by spontaneous fission.

Isotopes are the nuclides having the same atomic number Z but different mass number A . Isotopes exhibit the same chemical properties. Examples of carbon isotopes are ^{11}C , ^{12}C , and ^{13}C .

¹³²*Isotones* are the nuclides having the same number of neutrons ^{132}N but different numbers of protons. Examples of isotones are: ^{134}Cs , ^{133}Xe , and ^{53}I each having 79 neutrons.

1.1.8. Chart of the Nuclides

Nearly 3000 nuclides, both stable and unstable, are arranged in the form of a chart, called the *chart of the nuclides*, a section of which is presented in Figure 1.3. Each square in the chart represents a specific nuclide, containing various information such as the half-life, type and energy of radiations, and so forth of the nuclide, and neutron capture cross section of the stable nuclide. The nuclides are arranged in increasing neutron number N horizontally and in increasing proton number Z vertically. Each horizontal group of squares contains all isotopes of the same element, whereas the vertical group contains all isotones with the same number of neutrons. For isomers, the square is subdivided into sections representing each isomer.

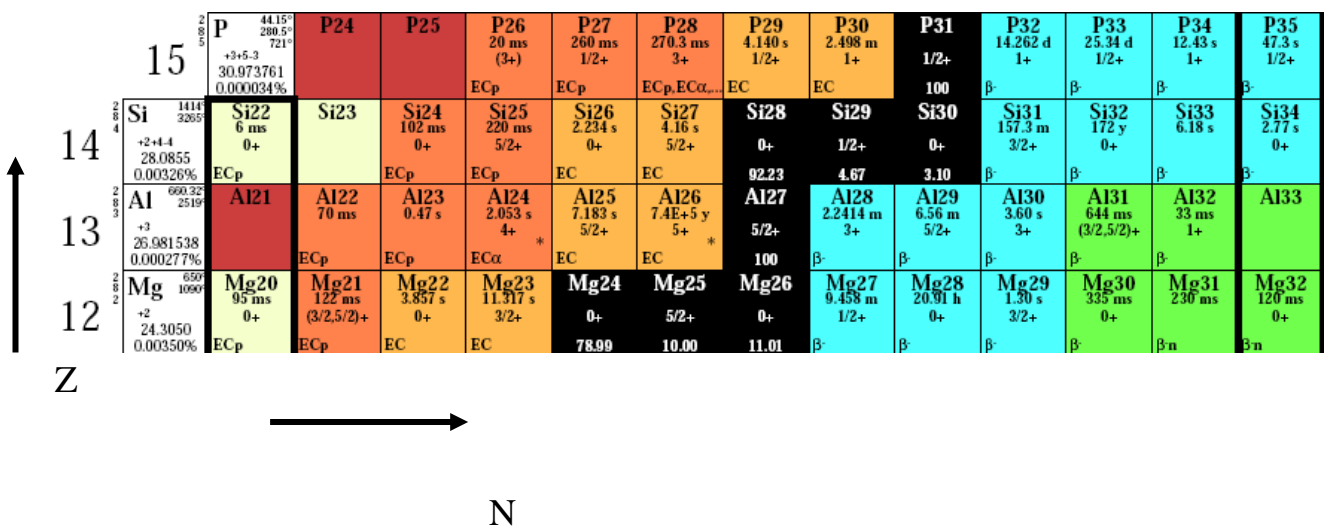

Fig. 1.3. A section of the chart of nuclides. (Courtesy of Knolls Atomic Power Laboratory, Schenectady, New York, operated by the General Electric Company for Naval Reactors, the U.S. Department of Energy.)

2. Radioactive Decay

In 1896, Henri Becquerel first discovered natural radioactivity in potassium uranyl sulfate. Artificial radioactivity was not produced until 1934, when I. Curie and F. Joliot made boron, aluminum, and magnesium radioactive by bombarding them with α -particles from polonium. Radionuclides are unstable and decay by emission of particle or γ -radiation to achieve stable configuration of protons and neutrons in the nucleus. As already mentioned, the stability of a nuclide in most cases is determined by the N/Z ratio of the nucleus. Thus, as will be seen later, whether a nuclide will decay by a particular particle emission or γ -ray emission is determined by the N/Z and/or excitation energy of the nucleus. Radionuclides can decay by one or more of the six modes: spontaneous fission, isomeric transition (IT), alpha (α) decay, beta (β^-) decay, positron (β^+) decay, and electron capture (EC) decay. In all decay modes, energy, charge, and mass are conserved. Different decay modes of radionuclides are described later in detail.

2.1. Spontaneous Fission

Fission is a process in which a heavy nucleus breaks into two fragments accompanied by the emission of two or three neutrons. The neutrons carry a mean energy of 1.5 MeV and the process releases about 200 MeV energy that appears mostly as heat.

Spontaneous fission occurs in heavy nuclei, but its probability is low and increases with mass number of the nuclei. The half-life for spontaneous fission is 2×10^{17} years for ^{235}U and only 55 days for ^{254}Cf . As an alternative to the spontaneous fission, the heavy nuclei can decay by α -particle or γ -ray emission.

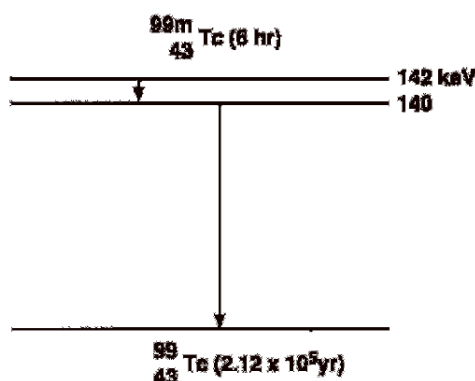

Fig. 2.1. Isomeric transition of $^{99\text{m}}\text{Tc}$. Ten percent of the decay follows internal conversion.

2.2. Internal Conversion

An alternative to the γ -ray emission is the *internal conversion* process. The excited nucleus transfers the excitation energy to an orbital electron—preferably the *K*-shell electron—of its own atom, which is then ejected from the shell, provided the excitation energy is greater than the binding energy of the electron (Fig. 2.2). The ejected electron is called the *conversion electron* and carries the kinetic energy equal to $E_g - EB$, where E_g is the excitation energy and EB is the binding energy of the electron. Even though the *K*-shell electrons are more likely to be ejected because of the proximity to the nucleus, the electrons from the *L* shell, *M* shell, and so forth also may undergo the internal conversion process. The ratio of the number of conversion electrons (N_e) to the number of observed γ -radiations (N_g) is referred to as the *conversion coefficient*, given as $a = N_e/N_g$. The conversion coefficients are subscripted as $a_K, a_L, a_M \dots$ depending on which shell the electron is ejected from. The total conversion coefficient a_T is then given by

$$\alpha_T = \alpha_K + \alpha_L + \alpha_M + \dots$$

Problem 2.1

If the total conversion coefficient (α_T) is 0.11 for the 140-keV γ -rays of ^{99m}Tc , calculate the percentage of 140-keV γ -radiations available for imaging.

Answer

$$\alpha_T = \frac{N_e}{N_\gamma} = 0.11$$

$$N_e = 0.11 N_\gamma$$

Total number of disintegrations

$$\begin{aligned} &= N_e + N_\gamma \\ &= 0.11N_\gamma + N_\gamma \\ &= 1.11N_\gamma \end{aligned}$$

Thus, the percentage of γ -radiations

$$\begin{aligned} &= \frac{N_\gamma}{1.11N_\gamma} \times 100 \\ &= \frac{1}{1.11} \times 100 \\ &= 90\% \end{aligned}$$

An internal conversion process leaves an atom with a vacancy in one of its shells, which is filled by an electron from the next higher shell. Such situations may also occur in nuclides decaying by electron capture (see later). When an L electron fills in a K -shell vacancy, the energy difference between the K shell and the L shell appears as a *characteristic K x-ray*. Alternatively, this transition energy may be transferred to an orbital electron, which is emitted with a kinetic energy equal to the characteristic x-ray energy minus its binding energy. These electrons are called *Auger electrons*, and the process is termed the *Auger process*, analogous to internal conversion. The Auger electrons are monoenergetic. Because the characteristic x-ray energy (energy difference between the two shells) is always less than the binding energy of the K -shell electron, the latter cannot undergo the Auger process and cannot be emitted as an Auger electron.

The vacancy in the shell resulting from an Auger process is filled by the transition of an electron from the next upper shell, followed by emission of similar characteristic x-rays and/or Auger electrons. The fraction of vacancies in a given shell that are filled by emitting characteristic x-ray emissions is called the *fluorescence yield*, and the fraction that is filled by the Auger processes is the *Auger yield*. The Auger process increases with the increasing atomic number of the atom.

2.2.1. Isomeric Transition

A nucleus can exist in different energy or excited states above the ground state, which is considered as the state involving the arrangement of protons and neutrons with the least amount of energy. These excited states are called the isomeric states and have lifetimes of fractions of picoseconds to many years. When isomeric states are long-lived, they are referred to as metastable states and denoted by “m” as in ^{99m}Tc . An excited nucleus decays to a lower energy state by giving off its energy, and such transitions are called isomeric transitions (ITs). Several isomeric transitions may occur from intermediate excited states prior to reaching the ground state. As will be seen later, a parent radionuclide may decay to an upper isomeric state of the product nucleus by α -particle or β -particle emission, in which case the isomeric state returns to the ground state by one or more isomeric transitions. A typical isomeric transition of ^{99m}Tc is illustrated in Figure 2.1. Isomeric transitions can occur in two ways: gamma (γ)-ray emission and internal conversion.

2.2.2. Gamma (γ)-Ray Emission

The common mode of an isomeric transition from an upper energy state of a nucleus to a lower energy state is by emission of an electromagnetic radiation, called the γ -ray. The energy of the γ -ray emitted is the difference between the two isomeric states. For example, a decay of a 525-keV isomeric state to a 210-keV isomeric state will result in the emission of a 315-keV γ -ray.

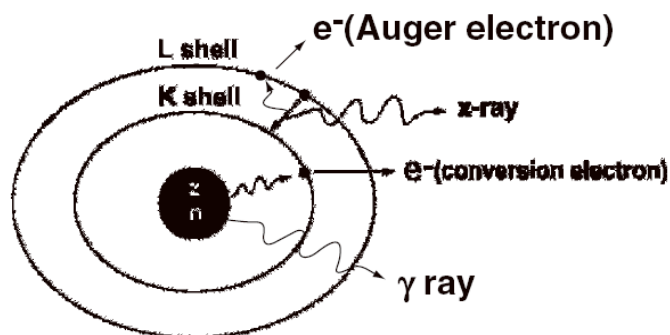
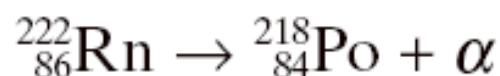

Fig. 2.2. Internal conversion process.

The excitation energy of the nucleus is transferred to a K -shell electron, which is then ejected, and the K -shell vacancy is filled by an electron from the L shell. The energy difference between the L shell and K shell appears as the characteristic K x-ray. Alternatively, the characteristic K x-ray may transfer its energy to an L -shell electron, called the Auger electron, which is then ejected.

2.3. Alpha (α)-Decay

The α -decay occurs mostly in heavy nuclides such as uranium, radon, plutonium, and so forth. Beryllium-8 is the only lightest nuclide that decays by breaking up into two α -particles. The α -particles are basically helium ions with two protons and two neutrons in the nucleus and two electrons removed from the helium atom. After α -decay, the atomic number of the nucleus is reduced by 2 and the mass number by 4.



The α -particles from a given radionuclide all have discrete energies corresponding to the decay of the initial nuclide to a particular energy level of the product (including, of course, its ground state). The energy of the α -particles is, as a rule, equal to the energy difference between the two levels and ranges from 1 to 10 MeV. The α -particles can be stopped by a piece of paper, a few centimeters of air, and gloves.

2.4. Beta (β^-) - Decay

When a radionuclide is neutron rich—that is, the N/Z ratio is greater than that of the nearest stable nuclide—it decays by the emission of a β^- -particle and an antineutrino. In the β^- -decay process, a neutron is converted to a proton, thus raising the atomic number Z of the product by 1. Thus:

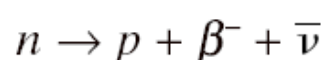

The difference in energy between the parent and daughter nuclides is called the *transition or decay energy*, denoted by E_{max} . The β^- -particles carry E_{max} or part of it, exhibiting a spectrum of energy as shown in Figure 2.3. The average energy of the β^- -particles is about one-third of E_{max} . This observation indicates that β^- -particles often carry only a part of the transition energy, and energy is not apparently conserved in β^- -decay. To satisfy the law of energy conservation, a particle called the *antineutrino* $\bar{\nu}$, with no charge and a negligible mass has been postulated, which carries the remainder of E_{max} in each β^- -decay. The existence of antineutrinos has been proven experimentally.

After β^- -decay, the daughter nuclide may exist in an excited state, in which case, one or more γ -ray emissions or internal conversion will occur to dispose of the excitation energy. In other words, β^- -decay is followed by isomeric transition if energetically permitted.

The decay process of a radionuclide is normally represented by what is called the *decay scheme*. Typical decay schemes of ^{131}I and ^{99}Mo are shown in Figures 2.4 and 2.5, respectively. The β^- -decay is shown by a left-to-right arrow from the parent nuclide to the daughter nuclide, whereas the isomeric transition is displayed by a vertical arrow between the two states. Note: The β^+ -decay is shown by a two-step right-to-left arrow between the two states, the electron capture decay by a right-to-left arrow, and the α -decay by a down arrow). Although it is often said that ^{131}I emits 364-keV γ -rays, it should be understood

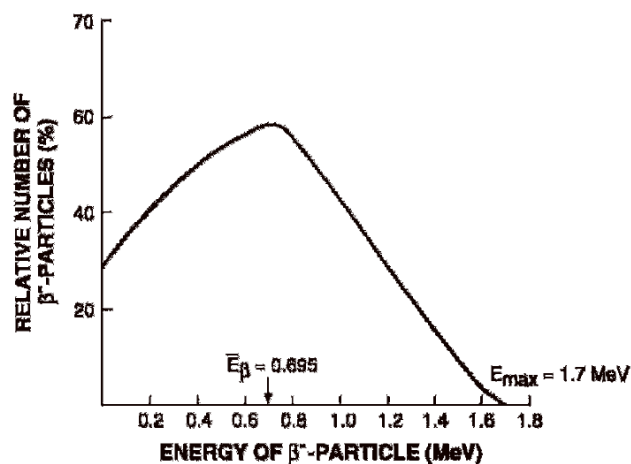

that the 364-keV γ -ray belongs to ^{131}Xe as

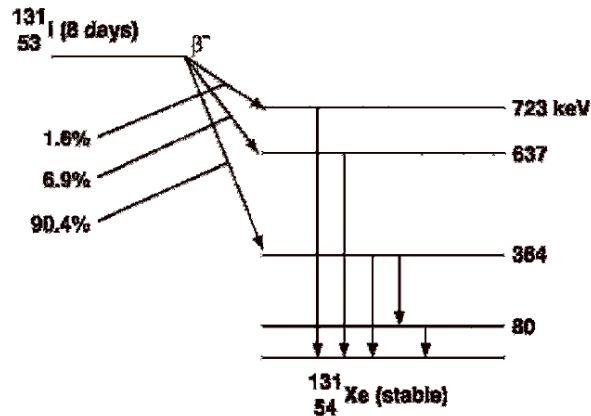

Fig. 2.3. A typical energy spectrum of the β^- particles of ^{32}P .

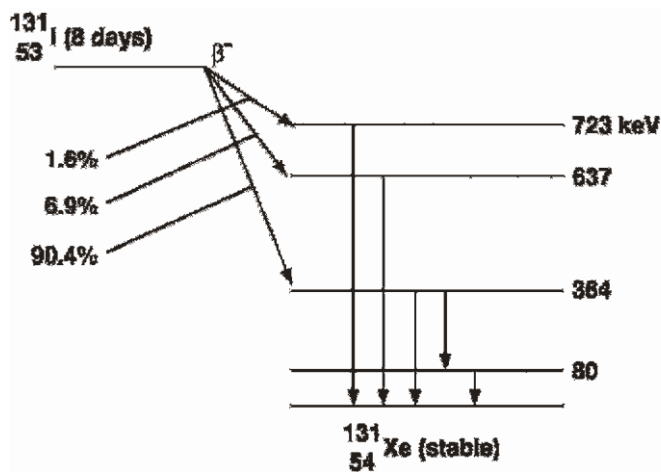

Fig. 2.4. Decay scheme of ^{131}I . Eighty-one percent of the total ^{131}I radionuclides decay by 364-keV γ -ray emission. The 8.0-day half-life of ^{131}I is shown in parentheses.

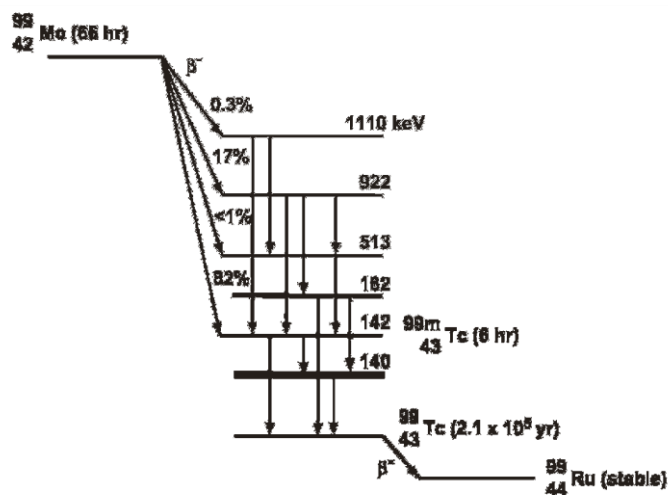
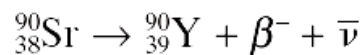
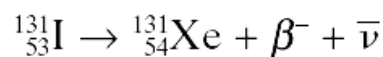
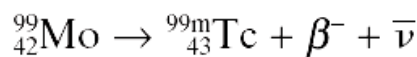

Fig. 2.5. Decay scheme of ^{99}Mo . Approximately 87% of the total ^{99}Mo ultimately decays to $^{99\text{m}}\text{Tc}$, and the remaining 13% decays to ^{99}Tc . A 2-keV transition occurs from the 142-keV level to the 140-keV level. All the 2-keV γ -rays are internally converted. (The energy levels are not shown in scale.) an isomeric state. This is true for all β^- , β^+ , or electron capture decays that are followed by γ -ray emission.

Some examples of β^- -decay follow:



It should be noted that in β^- -decay, the atomic number of the daughter nuclide is increased by 1 and the mass number remains the same.

2.5. Positron (β^+) - Decay

When a radionuclide is proton rich—that is, the N/Z ratio is low relative to that of the nearest stable nuclide—it can decay by positron (β^+) emission accompanied by the emission of a neutrino (ν), which is an opposite entity of the antineutrino. Positron emission takes place only when the energy difference (transition energy) between the parent and daughter nuclides is greater than 1.02 MeV. In β^+ -decay, essentially a proton is converted to a neutron plus a positron, thus, decreasing the atomic number Z of the daughter nuclide by 1. Thus,

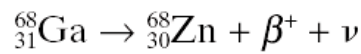
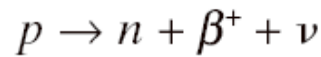

The requirement of 1.02 MeV for β^+ -decay arises from the fact that one electron mass has to be added to a proton to produce a neutron and one positron is created. Since each electron or positron mass is equal to 0.511 MeV, one electron and one positron are equal to 1.02 MeV, which is required as a minimum for β^+ -decay.

Some examples of β^+ -decay follow:

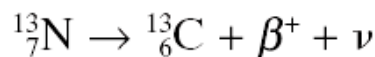

The energetic β^+ -particle loses energy while passing through matter. The range of positrons is short in matter. When it loses almost all of its energy, it combines with an atomic electron of the medium and is annihilated, giving rise to two photons of 511 keV emitted in opposite directions. These photons are called *annihilation radiations*.

The decay scheme of ${}^{68}\text{Ga}$ is presented in Figure 2.6. Note that the β^+ -decay is represented by a two-step right-to-left arrow.

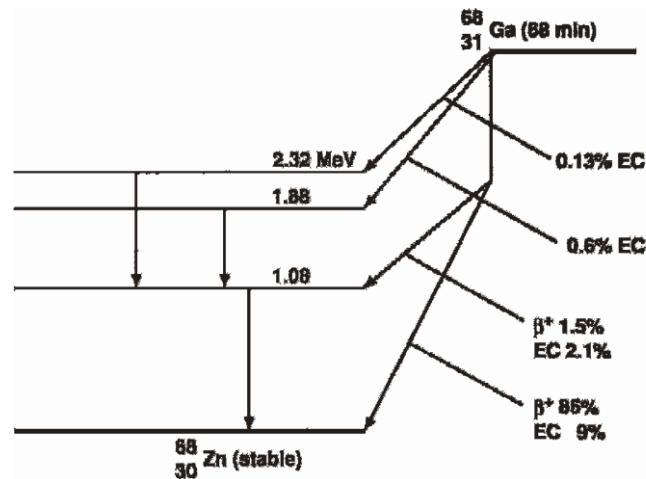

Fig. 2.6. Decay scheme of ^{68}Ga . The positrons are annihilated in medium to give rise to two 511-keV γ -rays emitted in opposite directions.

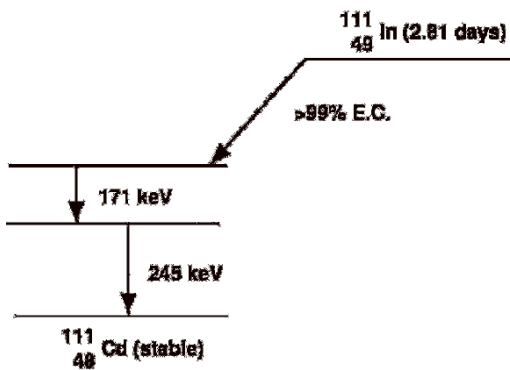
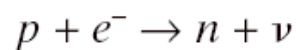

Fig. 2.7. Decay scheme of ^{111}In illustrating the electron capture process. The abundances of 171-keV and 245-keV γ -rays are 90% and 94%, respectively.

2.6. Electron Capture

Decay by electron capture (EC) is an alternative to the β^+ -decay for protonrich radionuclides with N/Z lower than that of the stable nuclide. In EC decay, an electron from an extranuclear shell, particularly the K shell because of its proximity, is captured by a proton in the nucleus, forming a neutron accompanied by the emission of a neutrino for conservation of energy. Thus,



In this process, the atomic number of the daughter nuclide is lowered by 1. The

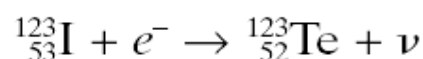
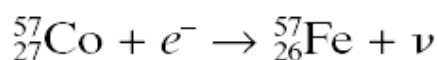
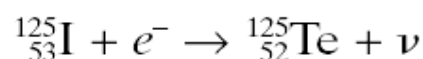
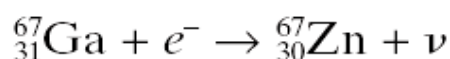
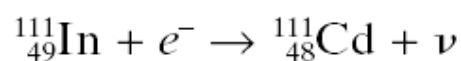

EC process occurs usually in nuclides having excitation energy less than 1.02 MeV. In nuclides having excitation energy greater than 1.02 MeV, both EC and β^+ -decay can occur, although the probability of β^+ -decay increases with higher excitation energy. The decay scheme of ^{111}In is shown in Figure 2.7. The EC decay is indicated by a right-to-left arrow. Some examples of EC decay follow:

In EC decay, analogous to the situation in internal conversion, a vacancy is created in the shell from which the electron is captured. It is filled in by the transition of an electron from the next upper shell, in which case the difference in energy between the two shells appears as a characteristic x-ray of the daughter nuclide. Also, as described earlier, instead of characteristic x-ray emission, the Auger process can occur, whereby an Auger electron is emitted.

3. Kinetics of Radioactive Decay

3.1. Radioactive Decay Equations

3.1.1. General Equation

Radionuclides decay by spontaneous fission, α -, β^- , and β^+ -particle emissions, electron capture, or isomeric transition. The radioactive decay is a random process, and it is not possible to tell which atom from a group of atoms disintegrates at a specific time. Thus, one can only talk about the average number of radionuclides disintegrating during a period of time. This gives the disintegration rate of a particular radionuclide.

The disintegration rate of a radionuclide, that is, the number of disintegrations per unit time, given as $-dN/dt$, is proportional to the total number of radioactive atoms present at that time. Mathematically,

$$-dN/dt = \lambda N \quad (3.1)$$

where N is the number of radioactive atoms present, and λ is referred to as the *decay constant* of the radionuclide. As can be seen from Eq. (3.1), it is a small fraction of the radioactive atoms that decays in a very short period of time. The unit of λ is $(\text{time})^{-1}$. Thus, if λ is 0.2 sec^{-1} for a radionuclide, then 20% of the radioactive atoms present will disappear per second.

The disintegration rate $-dN/dt$ is referred to as the *radioactivity* or simply the *activity* of the radionuclide and denoted by A . It should be understood from Eq. (3.1) that the same amount of radioactivity means the same disintegration rate for any radionuclide, but the total number of atoms present and the decay constants differ for different radionuclides. For example, a radioactive sample A containing 10^6 atoms and with $\lambda = 0.01 \text{ min}^{-1}$ would give the same disintegration rate (10,000 disintegrations per minute) as that by a radioactive sample B containing 2×10^6 atoms and with a decay constant 0.005 min^{-1} .

Now from the preceding discussion, the following equation can be

written:

$$A = \lambda N \quad (3.2)$$

From a knowledge of the decay constant and radioactivity of a radionuclide, one can calculate the total number of atoms or mass of the radionuclides present (using Avogadro's number $1 \text{ g} \cdot \text{atom} = 6.02 \times 10^{23}$ atoms).

Because Eq. (3.1) is a first-order differential equation, the solution of this equation by integration leads to

$$N_t = N_0 e^{-\lambda t} \quad (3.3)$$

where N_0 and N_t are the number of radioactive atoms at $t = 0$ and time t , respectively. Equation (3.3) is an exponential equation indicating that the radioactivity decays exponentially. By multiplying both sides of Eq. (3.3) by λ , one obtains

$$A_t = A_0 e^{-\lambda t} \quad (3.4)$$

The factor $e^{-\lambda t}$ is called the *decay factor*. The decay factor becomes $e^{+\lambda t}$ if the activity at time t before $t = 0$ is to be determined. The plot of activity versus time on a linear graph gives an exponential curve, as shown in Figure 3.1. However, if the activity is plotted against time on semilogarithmic paper, a straight line results, as shown in Figure 3.2.

3.1.2. General Equation

3.1.2.1. Half-Life

Every radionuclide is characterized by a *half-life*, which is defined as the time required to reduce its initial activity to one half. It is usually denoted

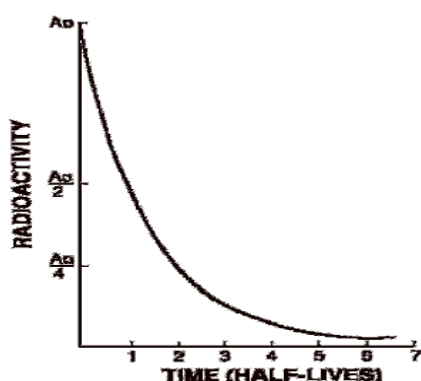
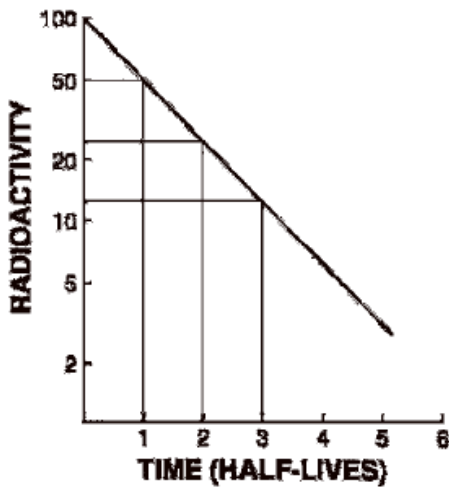

Fig. 3.1. Plot of radioactivity versus time on a linear graph indicating an exponential curve.

Fig. 3.2. Plot of radioactivity against time on a semilogarithmic graph indicating a straight line.



The half-life of the radionuclide can be determined from the slope of the line, which is given as the decay constant λ . Alternatively, an activity and half its value and their corresponding times are read from the plot. The difference in the two time readings gives the half-life.

by $t_{1/2}$ and is unique for a radionuclide. It is related to the decay constant λ of a radionuclide by

$$\lambda = \frac{0.693}{t_{1/2}} \quad (3.5)$$

From the definition of half-life, it is understood that A_0 is reduced to $A_0/2$ in one half-life; to $A_0/4$, that is, to $A_0/2^2$ in two half-lives; to $A_0/8$, that is, to $A_0/2^3$ in three half-lives; and so forth. In n half-lives of decay, it is reduced to $A_0/2^n$. Thus, the radioactivity A_t at time t can be calculated from the initial radioactivity A_0 by

$$A_t = \frac{A_0}{2^n} = \frac{A_0}{2^{(t/t_{1/2})}} = A_0(0.5)^{t/t_{1/2}} \quad (3-6)$$

where t is the time of decay. Here, $t/t_{1/2}$ can be an integer or a fraction depending on t and $t_{1/2}$. For example, a radioactive sample with $t_{1/2} = 3.2$ days decaying at a rate of 10,000 disintegrations per minute would give, after 7 days of decay, $10,000/2^{(7/3.2)} = 10,000/2^{2.2} = 10,000/4.59 = 2178$ disintegrations per minute.

It should be noted that ten half-lives of decay reduce the radioactivity by a factor of about 1000 ($2^{10} = 1024$), or to 0.1% of the initial activity.

The half-life of a radionuclide is determined by measuring the radioactivity at different time intervals and plotting them on semilogarithmic paper, as shown in Figure 3.2. An initial activity and half its value are read from the line, and the corresponding times are noted. The difference in time between the two readings gives the half-life of the radionuclide. For a very long-lived radionuclide, the half-life is determined by Eq. (3.2) from a knowledge of its activity and the number of atoms present. The number of atoms N can be calculated from the weight W of the radionuclide with atomic weight A and Avogadro's number 6.02×10^{23} atoms per g·atom as follows:

$$N = \frac{W}{A} \times 6.02 \times 10^{23} \quad (3.7)$$

When two or more radionuclides are present in a sample, the measured count of such a sample comprises counts of all individual radionuclides. A semilogarithmic plot of the activity of a two-component sample versus time is shown in Figure 3.3. The half-life of each of the two radionuclides can be determined by what is called the *peeling or stripping method*. In this method, first, the tail part (second component) of the curve is extrapolated as a straight line up to the ordinate, and its half-life can be determined as mentioned previously (e.g., 27 hr). Second, the activity values on this line are subtracted from those on the composite line to obtain the activity values for the first component. A straight line is drawn through these points, and the half-life of the first component is determined (e.g., 5.8 hr).

The stripping method can be applied to more than two components in the similar manner.

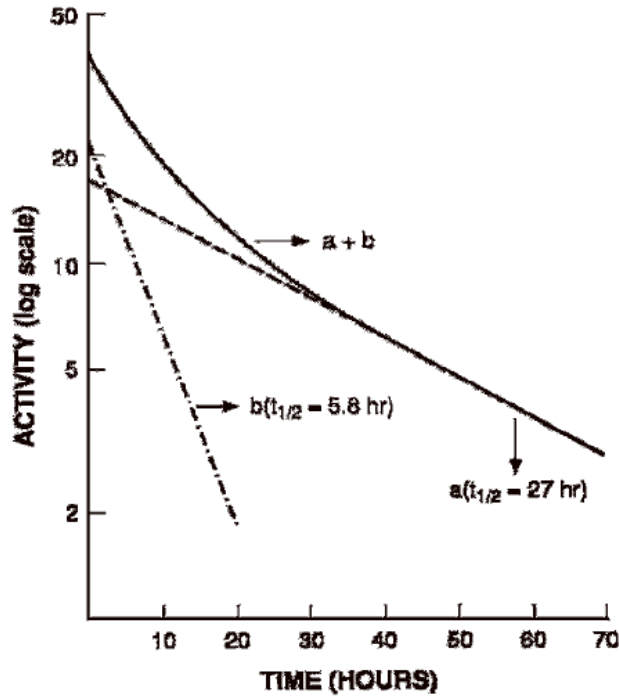

Fig. 3.3. A composite radioactive decay curve for a sample containing two radionuclides of different half-lives. The long-lived component (a) has a half-life of 27 hr and the short-lived component (b) has a half-life of 5.8 hr.

3.1.2.2. Mean Life

Another relevant quantity of a radionuclide is its *mean life*, which is the average lifetime of a group of radionuclides. It is denoted by τ and is related to the decay constant λ and half-life $t_{1/2}$ as follows:

$$\tau = 1/\lambda \quad (3.8)$$

$$\tau = t_{1/2}/0.693 = 1.44 t_{1/2} \quad (3.9)$$

In one mean life, the activity of a radionuclide is reduced to 37% of its initial value.

3.1.2.3. Effective Half-Life

As already mentioned, a radionuclide decays exponentially with a definite half-life, which is called the *physical half-life*, denoted by T_p (or $t_{1/2}$). The physical half-life of a radionuclide is independent of its physicochemical conditions. Analogous to physical decay, radiopharmaceuticals administered to humans disappear exponentially from the biological system through fecal excretion,

urinary excretion, perspiration, or other routes. Thus, after in vivo administration every radiopharmaceutical has a *biological half-life* (T_b), which is defined as the time needed for half of the radio-pharmaceutical to disappear from the biologic system. It is related to decay constant λ_b by $\lambda_b = 0.693/T_b$.

Obviously, in any biologic system, the loss of a radiopharmaceutical is due to both the physical decay of the radionuclide and the biologic elimination of the radiopharmaceutical. The net or effective rate (λ_e) of loss of radioactivity is then related to λ_p and λ_b by

$$\lambda_e = \lambda_p + \lambda_b \quad (3.10)$$

Because $\lambda = 0.693/t_{1/2}$, it follows that

The effective half-life, T_e , is always less than the shorter of T_p or T_b . For a very long T_p and a short T_b , T_e is almost equal to T_b . Similarly, for a very long T_b and short T_p , T_e is almost equal to T_p .

$$\frac{1}{T_e} = \frac{1}{T_p} + \frac{1}{T_b} \quad (3.11)$$

or,

$$T_e = \frac{T_p \times T_b}{T_p + T_b} \quad (3.12)$$

3.1.3. Units of Radioactivity

The unit of radioactivity is a curie. It is defined as

$$\begin{aligned} 1 \text{ curie (Ci)} &= 3.7 \times 10^{10} \text{ disintegrations per second (dps)} \\ &= 2.22 \times 10^{12} \text{ disintegrations per minute (dpm)} \end{aligned}$$

$$\begin{aligned} 1 \text{ millicurie (mCi)} &= 3.7 \times 10^7 \text{ dps} \\ &= 2.22 \times 10^9 \text{ dpm} \end{aligned}$$

$$\begin{aligned} 1 \text{ microcurie (}\mu\text{Ci)} &= 3.7 \times 10^4 \text{ dps} \\ &= 2.22 \times 10^6 \text{ dpm} \end{aligned}$$

Similarly,

$$1 \text{ Ci} = 3.7 \times 10^{10} \text{ Bq} = 37 \text{ GBq}$$

$$1 \text{ mCi} = 3.7 \times 10^7 \text{ Bq} = 37 \text{ MBq}$$

$$1 \mu\text{Ci} = 3.7 \times 10^4 \text{ Bq} = 37 \text{ kBq}$$

3.2. Successive Decay Equations

3.2.1. General Equation

In the preceding section, we derived equations for the activity of any radionuclide that is decaying. Here we shall derive equations for the activity of a radionuclide that is growing from another radionuclide and at the same time is itself decaying.

If a parent radionuclide p decays to a daughter radionuclide d , which in turn decays to another radionuclide (i.e., $p \rightarrow d \rightarrow$), then the rate of growth of d becomes

$$\frac{dN_d}{dt} = \lambda_p N_p - \lambda_d N_d \quad (3.13)$$

By integration, Eq. (3.13) becomes

$$(A_d)_t = \lambda_d N_d = \frac{\lambda_d (A_p)_0}{\lambda_d - \lambda_p} (e^{-\lambda_p t} - e^{-\lambda_d t}) \quad (3.14)$$

Equation (3.14) gives the activity of the daughter nuclide d at time t as a result of growth from the parent nuclide p and also due to the decay of the daughter itself.

3.2.2. Transient Equilibrium

If $\lambda_d > \lambda_p$, that is, $(t_{1/2})_d < (t_{1/2})_p$, then $e^{-\lambda_d t}$ in Eq. (3.15) is negligible compared to $e^{-\lambda_p t}$ when t is sufficiently long. Then Eq. (3.14) becomes

$$(A_d)_t = \frac{\lambda_d (A_p)_0}{\lambda_d - \lambda_p} e^{-\lambda_p t} \quad (3.15)$$

$$= \frac{\lambda_d (A_p)_t}{\lambda_d - \lambda_p} \quad (3.16)$$

$$= \frac{(t_{1/2})_p (A_p)_t}{(t_{1/2})_p - (t_{1/2})_d}$$

This relationship is called the *transient equilibrium*. This equilibrium holds good when $(t_{1/2})_p$ and $(t_{1/2})_d$ differ by a factor of about 10 to 50. The semilogarithmic plot of this equilibrium equation is shown in Figure 3.4. The daughter nuclide initially builds up as a result of the decay of the parent nuclide, reaches a maximum, and then achieves the transient equilibrium decaying with an apparent half-life of the parent nuclide. At equilibrium, the ratio of the daughter to parent activity is constant. It can be seen from Eq. (3.16) that the daughter activity is always greater than the parent activity, because $(t_{1/2})_p / [(t_{1/2})_p - (t_{1/2})_d]$ is always greater than 1. The time to reach maximum daughter activity is given by the formula:

$$t_{\max} = \frac{1.44 \times (t_{1/2})_p \times (t_{1/2})_d \times \ln[(t_{1/2})_p / (t_{1/2})_d]}{[(t_{1/2})_p - (t_{1/2})_d]} \quad (3.17)$$

A typical example of transient equilibrium is ^{99}Mo ($t_{1/2} = 66$ hr) decaying to $^{99\text{m}}\text{Tc}$ ($t_{1/2} = 6$ hr). Because 87% of ^{99}Mo decays to $^{99\text{m}}\text{Tc}$, and the

remaining 13% to the ground state, Eqs. (3.14), (3.15), and (3.16) must be multiplied by a factor of 0.87. Therefore, in the time–activity plot, the ^{99m}Tc daughter activity will be lower than the ^{99}Mo parent activity (Fig. 3.5). Also, the ^{99m}Tc activity reaches maximum in about 23 hr, i.e., $4(t_{1/2})_d$ [Eq. (3.17)].

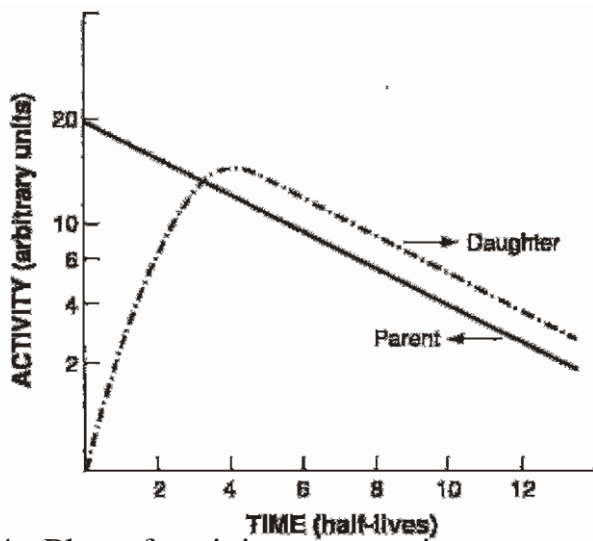

Fig. 3.4. Plot of activity versus time on a semilogarithmic graph illustrating the transient equilibrium. Note that the daughter activity reaches a maximum, then transient equilibrium, and follows an apparent half-life of the parent. The daughter activity is higher than the parent activity at equilibrium.

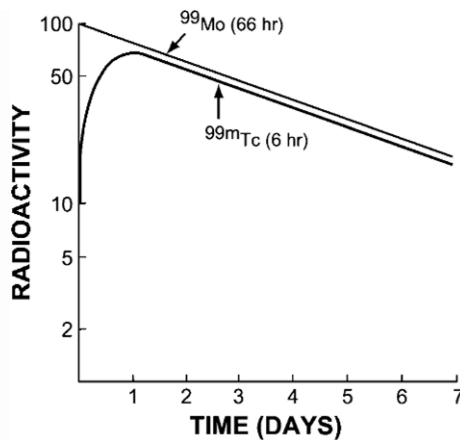
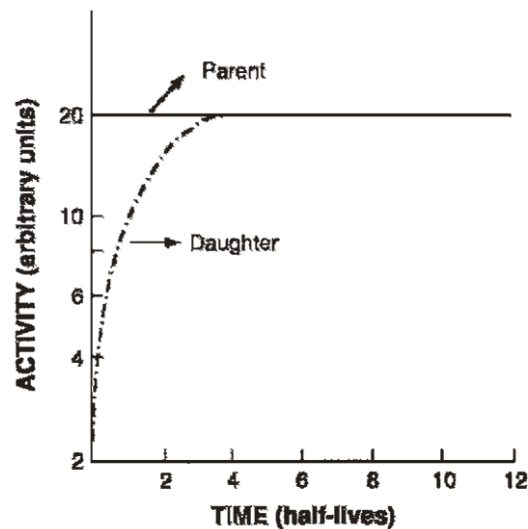

Fig. 3.5. Plot of logarithm of ^{99}Mo and ^{99m}Tc activities versus time showing transient equilibrium. The activity of the daughter ^{99m}Tc is less than that of the

parent ^{99}Mo , because only 87% of ^{99}Mo decays to $^{99\text{m}}\text{Tc}$. If 100% of the parent were to decay to the daughter, then the daughter activity would be higher than the parent activity after reaching equilibrium, as recognized from Eq. (3.15), and Figure 3.4.

Fig. 3.6. Plot of activity versus time illustrating secular equilibrium. In equilibrium,



the daughter activity becomes equal to that of the parent.

3.2.3. Secular Equilibrium

When $\lambda_d \gg \lambda_p$, that is, when the parent half-life is much longer than that of the daughter nuclide, in Eq. (3.15), we can neglect λ_p compared to λ_d . Then Eq. (3.15) becomes

$$(A_d)_t = (A_p)_t \quad (3.18)$$

Equation (3.18) is called the *secular equilibrium*. This equilibrium holds when the half-life of the parent is much longer than that of the daughter nuclide by more than a factor of 100 or so. In secular equilibrium, both parent and daughter activities are equal, and both decay with the half-life of the parent nuclide. A semilogarithmic plot of activity versus time representing secular equilibrium is shown in Figure 3.6. Typical examples of secular equilibrium are ^{113}Sn ($t_{1/2} = 117$ days) decaying to $^{113\text{m}}\text{In}$ ($t_{1/2} = 100$ min), and ^{68}Ge ($t_{1/2} = 280$ days) decaying to ^{68}Ga ($t_{1/2} = 68$ min).

4. Internal Radiation Dosimetry

Radiation can cause detrimental effects on human tissues, and these effects depend on various factors, such as dose, dose rate, time of exposure and so on. This chapter describes the method of calculating absorbed doses in various organs from radionuclides ingested internally either purposely (e.g., medical procedures) or accidentally.

4.1. Radiation Units

Three units of measure are related to radiation: the roentgen (R) for exposure, the rad (radiation absorbed dose) for absorbed dose, and the rem (roentgen equivalent man) for dose equivalent.

The *roentgen* is the amount of x- or γ -radiation that produces ionization of one electrostatic unit of either positive or negative charge per cubic centimeter of air at 0°C and 760 mm Hg standard temperature and pressure (STP). Because 1 cm³ air weighs 0.001293 g at STP and a charge of either sign carries 1.6×10^{-19} C or 4.8×10^{-10} electrostatic units, it can be shown that

$$1 \text{ R} = 2.58 \times 10^{-4} \text{ C/kg} \quad (4.1)$$

It should be noted that the roentgen applies only to air and to x- or γ -radiations. Because of practical limitations of the measuring instruments, the R unit is applicable only to photons of less than 3 MeV energy.

The *rad* is a more universal unit. It is a measure of the energy deposited per unit mass of any material by any type of radiation. The rad is specifically defined as

$$1 \text{ rad} = 100 \text{ ergs/g absorber} \quad (4.2)$$

Since 1 joule (J) = 10^7 ergs,

$$1 \text{ rad} = 10^{-2} \text{ J/kg} \quad (4.3)$$

Another radiation unit is *kerma* (acronym for kinetic energy released in matter) which is defined as the sum of initial kinetic energies of all charged

particles liberated by uncharged ionizing radiation per unit mass of material. For all practical purposes, kerma and rad are identical.

In SI units, the *gray* (Gy) is the unit of radiation absorbed dose and kerma and is given by

$$1 \text{ Gy} = 100 \text{ rad} \quad (4.4)$$

$$= 1 \text{ J/kg absorber} \quad (4.5)$$

It can be shown that the energy absorbed per kilogram of air due to an exposure of 1 R is Therefore, or,

$$R = 86.9 \times 10^{-4} \text{ J/kg in air}$$

$$1 \text{ R} = 0.869 \text{ rad in air}$$

$$1 \text{ R} = 0.00869 \text{ Gy in air}$$

The rad is not restricted by the type of radiation or absorber or by the energy or intensity of the radiation. It should be understood that the rad is independent of the weight of the material. This means that a radiation dose of 1 rad (0.01 Gy) is always 1 rad (0.01 Gy) in 1, 2, or 10 g of the material. However, the integral absorbed dose is given in units of gram-rad (g · rad or g · Gy) and calculated by multiplying the rad (Gy) by the mass of material. For example, if the radiation dose to a body of 45 g is 10 rad (0.1 Gy), then the integral radiation dose to the material is 450 g · rad (or 4.5 g · Gy); however, the radiation dose is still 10 rad (0.1 Gy).

The dose equivalent unit, *rem*, has been developed to account for the differences in effectiveness of different types of radiation in causing biological damage. In radiobiology, the rem is defined as

$$\text{rem} = \text{rad} \times \text{RBE} \quad (4.6)$$

where RBE is the relative biological effectiveness of the radiation. It is defined as the ratio of the dose of a standard radiation to produce a particular biological response to the dose of the radiation in question to produce the same biological response. Radiations of 250 KV x-rays are normally chosen

as the standard radiation because of their widespread use. RBE varies with the linear energy transfer (LET) of the radiation, radiation dose, dose rate, and the biological system in which RBE is determined.

In radiation protection, RBE is replaced by the *radiation weighting factor*, W_R , to account for differences in effectiveness of various radiations in causing biological damage. The rem is then defined as

Table 4.1. Radiation weighting factors.

Type and energy range	Radiation weighting factors, W_R
Photons, all energies	1
Electrons, muons, all energies	1
Neutrons, energy <10 keV	5
10 keV to 100 keV	10
>100 keV to 2 MeV	20
>2 MeV to 20 MeV	10
>20 MeV	5
Protons, other than recoil protons, energy >2 MeV	5
Alpha particles, fission fragments, heavy nuclei	20

Adapted with permission from ICRP Publication 60: *1990 Recommendations of the International Commission on Radiological Protection*. New York: Pergamon Press; 1991.

$$\text{rem} = \text{rad} \times W_R \quad (4.7)$$

The International Commission on Radiological Protection (ICRP) has suggested the W_R values for different radiations, which are listed in Table 4.1 (ICRP 60, 1991). These values depend on the LET of the radiation. When a radiation dose comes from several radiations, the total dose equivalent is calculated by adding the absorbed doses from individual radiations multiplied by the W_R of each radiation.

In the past, the W_R values were called *quality factors*, which are somewhat different from the W_R values. The US Nuclear Regulatory Commission (NRC) still adopts these values for regulatory purposes, and the values are listed in Table 4.2.

In SI units, the dose equivalent is expressed in *sievert*, which is defined as

$$1 \text{ sievert (Sv)} = 100 \text{ rem} \quad (4.8)$$

In practical situations, all these radiation units are often expressed in

milliroentgens (mR), millirads (mrad), and millirems (mrem), which are 10^{-3} times the units, roentgen, rad, and rem, respectively. In SI units, the equivalent quantities are milligrays (mGy) and millisieverts (mSv). A rad is also commonly expressed as centigray (cGy), one-hundredth of a gray.

Table 4.2. Quality factors for different radiations.

Type of radiation	QF
X-rays, γ -rays, β -particles	1.0
Neutrons and protons	10.0
α -Particles	20.0
Heavy ions	20.0

4.2. Dose Calculation

The radiation absorbed dose depends on a number of factors: (1) the amount of radioactivity administered; (2) the physical and biological half-lives of the radioactivity; (3) the fractional abundance of the radiation in question from the radionuclides; (4) the biodistribution of radioactivity in the body; and (5) the fraction of energy released from the source organ that is absorbed in the target volume, which is related to the shape, composition, and location of the target. The physical characteristics of a radionuclide are well established. Information concerning the biodistribution of ingested radioactivity can be obtained from various experimental studies in humans and animals. The factors 4 and 5 are variable from one individual to another and, therefore, they are approximated for a “standard” or “average” 70-kg man.

Radiopharmaceuticals administered to patients are distributed in different regions of the body. A region of interest for which the absorbed dose is to be calculated is considered the “target,” whereas all other regions contributing to the radiation dose to the target are considered “sources.” The source and the target become the same when the radiation dose due to the radioactivity in the target itself is calculated.

4.3. Radiation Dose Rate

Suppose a source volume r contains A mCi of a radiopharmaceutical emitting several radiations. If the i th radiation has energy E_i and a fractional

abundance N_i per disintegration, then the energy absorbed per hour (dose rate) by a target of mass m and volume v from the i th radiation emitted by the source volume r is given by

$$\begin{aligned}
 R_i(\text{rad/hr}) &= A/m(\text{mCi/g})N_iE_i(\text{MeV/disintegration}) \\
 &\quad \times [3.7 \times 10^4 \text{ disintegrations}/(\text{s} \cdot \text{mCi})] \\
 &\quad \times (1.6 \times 10^{-6} \text{ erg/MeV}) \\
 &\quad \times (0.01 \text{ g} \cdot \text{rad/erg}) \\
 &\quad \times (3600 \text{ s/hr}) \\
 &= 2.13(A/m)N_iE_i
 \end{aligned}$$

The above equation is valid for nonpenetrating radiations only, meaning all energy is absorbed in the absorber. For penetrating radiations, total or part of the radiation energy may be absorbed in the absorbing material. If the target and the source are not the same, then a factor must be introduced to account for the partial absorption, if any, of the radiation energy. Thus,

$$R_i(\text{rad/hr}) = 2.13(A/m)N_iE_i\phi_i(v \leftarrow r) \quad (4.9)$$

Here $\phi_i(v \leftarrow r)$ is called the *absorbed fraction* and is defined as the ratio of the energy absorbed by the target volume v from the i th radiation to the energy emitted by the i th radiation from the source volume r . This is a critical factor that is difficult to evaluate, because the absorbed fraction ϕ_i depends on the type and energy of the radiation, the shape and size of the source volume, and the shape, composition, and distance of the target volume. However, in the case of β -particles, conversion electrons, α -particles, and x- and γ -rays of energies less than 11 keV, all of the energy emitted by a radionuclide is absorbed in the volume r larger than 1 cm. Then, ϕ_i becomes 0, unless v and r are the same, in which case $\phi_i = 1$. For x- and γ -rays with energies greater than 11 keV, the value of ϕ_i decreases with increasing energy and varies between 0 and 1, depending on the energy. The values of ϕ_i are calculated by statistical Monte Carlo methods on the basis of fundamental mechanisms of interaction of

radiation with matter, and are available in standard textbooks on radiation dosimetry, particularly the medical internal radiation dose (MIRD) pamphlets published by the Society of Nuclear Medicine.

The quantity $2.13N_iE_i$ is a constant for the i th radiation and is often denoted by Δ_i . Thus,

$$\Delta_i = 2.13N_iE_i \quad (4.10)$$

The quantity Δ_i is called the *equilibrium dose constant* for the i th radiation and has the unit $\text{g} \cdot \text{rad}/(\text{mCi} \cdot \text{hr})$ based on the units chosen in Eq. (4.9). It should be pointed out that since β -particles are emitted with a distribution of energy, the average energy E_b of β -particles is used in the calculation of Δ_i . Thus, Eq. (4.9) becomes

$$R_i(\text{rad/hr}) = (A/m)\Delta_i\phi_i(v \leftarrow r) \quad (4.11)$$

The activity A will change due to the physical decay and biological elimination of the radiopharmaceutical, and therefore the dose rate will also change. If A_0 is the initial administered activity, then the activity localized in an organ is a fraction f of A_0 . Assuming an effective exponential change in A with time, Eq. (4.11) can be written

$$R_i(\text{rad/hr}) = (f \cdot A_0/m)\Delta_i e^{-\lambda_e t} \phi_i(v \leftarrow r) \quad (4.12)$$

Here λ_e is the effective decay constant of the radiopharmaceutical, and t is the time over which the original activity has decayed.

4.4. Cumulative Radiation Dose

The cumulative radiation dose D_i to the target due to the i th radiation of the radionuclide during the period $t = 0$ to t can be obtained by integrating Eq. (4.12). Thus,

$$D_i(\text{rad}) = (f \cdot A_0/m)\Delta_i\phi_i(v \leftarrow r) \int_0^t e^{-\lambda_e t} dt$$

$$\begin{aligned}
 &= (f \cdot A_o / m) \Delta_i \phi_i(v \leftarrow r) \frac{1}{\lambda_e} (1 - e^{-\lambda_e t}) \\
 &= 1.44 (f \cdot A_o / m) \Delta_i T_e (1 - e^{-\lambda_e t}) \phi_i(v \leftarrow r)
 \end{aligned} \tag{4.13}$$

Here, T_e is the effective half-life of the radiopharmaceutical in hours (discussed in Chapter 3). If $t = \infty$, that is, the radiopharmaceutical is completely eliminated, then the exponential term $e^{-\lambda_e t}$ approaches zero and the absorbed dose in Eq. (4.13) may be written as

$$\Delta i(\text{rad}) = 1.44 (f \cdot A_o / m) D_i T_e \phi_i(v \leftarrow r) \tag{4.14}$$

If the radionuclide has n radiations with energies E_1, E_2, \dots, E_n and fractional abundances N_1, N_2, \dots, N_n per disintegration, then the total dose D can be obtained by summing Eq. (4.14) over all radiations. Thus,

$$D_i(\text{rad}) = 1.44 (f \cdot A_o / m) T_e \sum_{i=1}^n \Delta_i \phi_i(v \leftarrow r) \tag{4.15}$$

This summation can also be applied to Eq. (4.12) for the dose rate R_i . The total dose to the target from different sources of radiations can be calculated by summing Eq. (4.15) over all sources.

In the MIRD pamphlets, the values of Δ_i have been compiled on the basis of various nuclear characteristics of the radionuclide in question. The ϕ_i values have been calculated on the basis of different sizes and compositions of the targets receiving the radiation dose and the radiation characteristics of the radionuclide. In MIRD pamphlet no. 11, Eq. (4.15) has been substituted by

$$D(\text{rad}) = \tilde{A} \cdot S \tag{4.16}$$

where

$$\tilde{A} = 1.44 \times f \cdot A_o \times T_e \tag{4.17}$$

$$S = \sum_{i=1}^n \Delta_i \phi_i / m \tag{4.18}$$

The quantity \tilde{A} is called the *cumulated activity* and has the unit of mCi·hr. The quantity S is called the *mean absorbed dose per cumulated activity* and has the unit of rad/mCi·hr. These two quantities are further discussed next.

Factors Affecting \tilde{A}

The cumulated activity \tilde{A} in Eq. (4.17) is given as

$$\tilde{A} = 1.44f \cdot A_o T_e$$

This is calculated on the assumption that the radiopharmaceutical localizes in the organs instantaneously and cleared by both physical decay and biological elimination.

There are situations when the uptake of the tracer is gradual and the clearance also is slow. In these cases,

$$\tilde{A} = 1.44f \cdot A_o T_e (T_Q/T_U) \quad (4.19)$$

where T_U is the biological uptake half-time, T_e is the effective excretion half-time [Eq. (3.12)] and T_Q is the effective uptake half-time. T_Q is calculated by Eq. (3.12) using the physical half-life T_P and the biological uptake half-time T_U .

Two other situations can occur when the uptake is instantaneous, but the T_P of the radionuclide is greater than the biological half-life T_B , or T_B is greater than T_P .

When $T_P \gg T_B$, the cumulated activity is given by

$$\tilde{A} = 1.44f \cdot A_o T_B \quad (4.20)$$

If the tracer is excreted by several excretion routes such as urinary excretion, fecal excretion, etc., the fraction of activity excreted and the effective halftime of

each mode are used to calculate the fractional cumulated activity of each mode, which are then summed to calculate the total cumulated activity.

When $T_B \gg TP$, the cumulated activity is calculated as

$$\tilde{A} = 1.44f \cdot A_0 TP \quad (4.21)$$

In this case, there is no biological excretion. The S Values

The mean absorbed dose per cumulated activity, S , is more appropriately expressed as

$$S(\nu \leftarrow r) = \frac{1}{m} \sum_{i=1}^n \Delta_i \phi_i(\nu \leftarrow r) \quad (4.22)$$

where the symbols ν and r represent the target and the source, respectively. The calculation of these values is quite laborious. The MIRD Committee of the Society of Nuclear Medicine calculates these values for radiopharmaceuticals commonly used in nuclear medicine and publish them periodically. Table 4.3 includes a partial list of S values for ^{99m}Tc obtained from MIRD pamphlet no. 11.

Problem 14.1

Calculate the absorbed dose to the lungs from the administration of 4 mCi

(148 MBq) ^{99m}Tc -MAA particles, assuming that 99% of the particles are trapped in the lungs. The value of S for the lungs is 5.2×10^{-5} rad/mCi·hr.

Assume that the ^{99m}Tc activity is uniformly distributed in the lungs and 45% of the activity is cleared from the lungs with a biological half-life of 3 hr and 55% with a biological half-life of 7 hr.

Answer

The half-life of $^{99m}\text{Tc} = 6$ hr. The effective half-life of two biological clearances are Using Eq. (4.17)

$$T_{e1} = \frac{3 \times 6}{3 + 6} = 2 \text{ hr}$$

$$T_{e2} = \frac{7 \times 6}{7 + 6} = 3.2 \text{ hr}$$

Using Eq. (14.17)

$$\begin{aligned} \tilde{A} &= 1.44 \times 4000 \times 0.99 \times (0.45 \times 2 + 0.55 \times 3.2) \\ &= 15,200 \mu\text{Ci} \cdot \text{hr} \quad (0.562 \text{ GBq} \cdot \text{hr}) \end{aligned}$$

$$\begin{aligned} D &= \tilde{A} \cdot S \\ &= 15200 \times 5.2 \times 10^{-5} \\ &= 0.79 \text{ rad} \\ &= 790 \text{ mrad} \quad (7.9 \text{ mGy}) \end{aligned}$$

4.5. Radiation Dose in SI Units

The radiation dose in System Internationale (SI) units due to the administration of a radiopharmaceutical can be calculated by assuming a source volume r containing A MBq of the radiopharmaceutical that emits several radiations. If the i th radiation has energy E_i and a fractional abundance N_i per disintegration, then the energy absorbed per hour by a target of mass m and volume v from the i th radiation emitted by the source volume r (dose rate) is given by

$$\begin{aligned} R_i(\text{Gy/hr}) &= A/m(\text{MBq/g})N_iE_i(\text{MeV/disintegration}) \\ &\quad \times 10^6 \text{ disintegrations}/(\text{s} \cdot \text{MBq}) \\ &\quad \times (1.6 \times 10^{-6} \text{ erg/MeV}) \\ &\quad \times (1 \times 10^{-4} \text{ g} \cdot \text{Gy/erg}) \\ &\quad \times (3600 \text{ s/hr}) \\ &= 0.576 (A/m)N_iE_i \end{aligned}$$

When the target and the source are not the same, the absorbed fraction $f_i(v \leftarrow r)$ must be taken into account. Thus,

$$R_i(\text{Gy/hr}) = 0.576(A/m)N_iE_i\phi_i(v \leftarrow r) \quad (4.23)$$

The quantity $0.576N_iE_i$ is a constant and can be denoted by D_i as in Eq. (4.10). Thus

$$\Delta_i = 0.576N_iE_i \quad (4.24)$$

With this value of D_i , Eqs. (4.11) to (4.18) are equally applicable to radiation doses in SI units. It should be understood that the equations in SI units contain a constant $\Delta_i = 0.576N_iE_i$ and activities expressed in MBq, whereas the equations in rad units contain the equilibrium dose constant $\Delta_i = 2.13N_iE_i$ and activities expressed in microcuries. Also note that A should be equal to $f \cdot A_0$, if A_0 is the initial administered activity.

4.6. Effective Dose Equivalent and Effective Dose

Historically, the whole-body dose or total body dose was used to evaluate the relative radiation risks of different procedures involving radiations. This quantity is calculated according to the MIRD method by using the S factor for the whole body as the source organ as well as the target organ. This value does not take into consideration the effect of tissue sensitivity to radiation.

In 1977 the ICRP introduced the concept of effective dose equivalent (EDE) to take into account the different sensitivity of tissues to radiation (ICRP 26). The tissues weighting factor (WT) for an organ was defined as the ratio of the whole-body dose, which would cause a certain probability of cancer induction to the absorbed dose in that organ which would cause the same probability of cancer induction in that organ. For example, a dose of 3 rem to the whole body causes some probability of cancer induction; a dose of 100 rem to the thyroid causes the same numerical probability of thyroid cancer induction. Then the WT for thyroid is equal to 0.03.

The *effective dose equivalent* (H_E) is defined as the sum of weighted dose equivalents in all tissues and organs, and is calculated as

$$H_E = \sum_T W_T H_T \quad (4.25)$$

where W_T is the tissue weighting factor for an organ and H_T is the dose equivalent (rem) to the organ. H_E can be explicitly written as

$$H_E = \sum_T W_T \sum_r W_r \times (\text{rad})_{T,r} \quad (4.26)$$

where $(\text{rad})_{T,r}$ is the absorbed dose to tissue T from radiation of type r and W_r is the radiation weighting factor discussed earlier.

The effective dose equivalent provides an overall risk estimate for an individual exposed to radiation, which is computed from dose equivalent to each organ that is weighted for tissue sensitivity. For assessment of risk versus benefit, the effective dose equivalent is a more appropriate parameter than the whole-body dose, because it takes into consideration the different tissue sensitivities of the organ. The W_T values are assigned such that their sum equals one.

In 1990, ICRP adopted a different set of W_T values and renamed the effective dose equivalent as simply the effective dose (ED) (ICRP 60).

Table 4.5 summarizes the W_T values recommended by ICRP for both EDE

Table 4.5. Tissue weighting factors W_T .

Tissue	W_T for EDE*	W_T for ED†
Gonads	0.25	0.20
Breast	0.15	0.05
Thyroid	0.03	0.05
Bone surfaces	0.03	0.01
Bone marrow (red)	0.12	0.12
Lung	0.12	0.12
Colon	not given	0.12
Stomach	not given	0.12
Bladder	not given	0.05
Liver	not given	0.05
Esophagus	not given	0.05
Skin	not given	0.01
Remainder	0.3	0.05
Total Body	1.0	1.0

* W_T values from 10CFR20. NRC adopted these values from ICRP 26 (1977).

† Adapted with permission from ICRP 60. *1990 Recommendations of International Commission of Radiological Protection*. New York: Elsevier, 1991.

(ICRP 26) and ED (ICRP 60). Some WT values are different and some are the same in the two schema, whereas others are not given in the EDE scheme. Because the radiosensitivity of tissues varies with age, the effective dose is age dependent. Table 4.6 lists the effective doses in adult humans from different nuclear medicine studies using various radiopharmaceuticals (ICRP 80, 1999).

4.7. Pediatric Dosages

The metabolism, biodistribution, and excretion of drugs are different in children from those in adults, and therefore radiopharmaceutical dosages for children must be adjusted. Several methods and formulas have been reported on pediatric dosage calculations based on body weight, body

Table 4.7. Fraction of adult administered dosages for pediatric administration.

Weight in kg (lb)	Fraction	Weight in kg (lb)	Fraction
3 (6.6)	0.1	28 (61.6)	0.58
4 (8.8)	0.1	30 (66.0)	0.62
8 (17.6)	0.2	32 (70.4)	0.65
10 (22.0)	0.2	34 (74.8)	0.68
12 (26.4)	0.3	36 (79.2)	0.71
14 (30.8)	0.3	38 (83.6)	0.73
16 (35.2)	0.4	40 (88.0)	0.76
18 (39.6)	0.4	42 (92.4)	0.78
20 (44.0)	0.4	44 (96.8)	0.80
22 (48.4)	0.5	46 (101.2)	0.83
24 (52.8)	0.5	48 (105.6)	0.85
26 (57.2)	0.5	50 (110.0)	0.88

Adapted from Paediatric Task Group European Association Nuclear Medicine Members. A radiopharmaceuticals schedule for imaging paediatrics. *Eur J Nucl Med.* 1990;17:127.

surface area, combination of weight and area, and simple ratios of adult dosages. The calculation based on body surface area is more accurate for pediatric dosages. The body surface area of a standard adult is 1.73 m^2 and proportional to the 0.7 power of the body weight. Based on the information, the Paediatric Task Group European Association Nuclear Medicine Members published the fractions of the adult dosages needed for children, which are shown in Table 14.7. For most nuclear studies, however, there is a minimum dosage required for a meaningful scan, which is normally established in each institution based on experience.

5. Radiation Biology

The subject of radiation biology deals with the effects of ionizing radiations on living systems. During the passage through living matter, radiation loses energy by interaction with atoms and molecules of the matter, thereby causing ionization and excitation. The ultimate effect is the alteration of the living cells. Radiation biology is a vast subject, and it is beyond the scope of this book to include the full details of the subject. The following is only a brief outline of radiation biology, highlighting the mechanism of radiation damage, radiosensitivity of tissues, different types of effect on living matter, and risks of cancer and genetic effects from radiation exposure.

5.1. The Cell

The cell is the building unit of living matter and consists of two primary components: the nucleus and the cytoplasm (Fig. 5.1). All metabolic activities are carried out in the cytoplasm under the guidance of the nucleus.

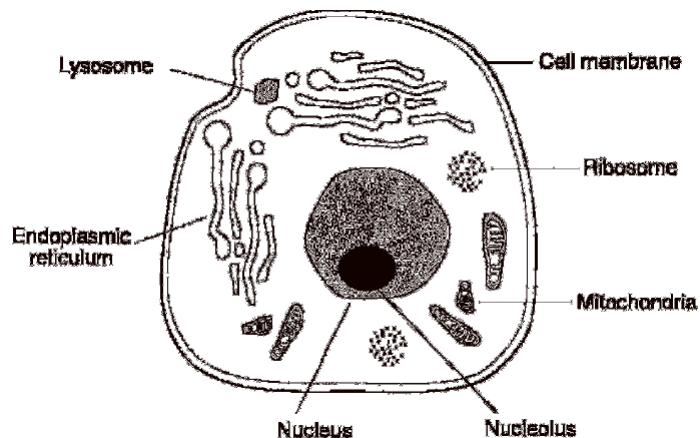

Fig. 5.1. Structure of a typical mammalian cell.

The nucleus contains chromosomes, which have a threadlike structure of two arms connected by a centromere (Fig. 5.2). Chromosomes are formed of genes, which are the basic units of heredity in the cells of all living species. Genes are composed of deoxyribonucleic acid (DNA) molecules. The struc- tural

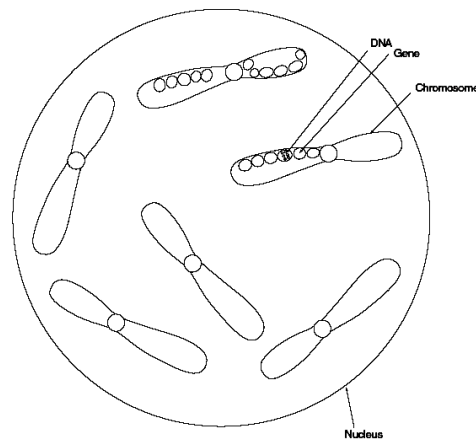

Fig. 5.2. Structural relationship of chromosomes, genes, and DNA molecules. The entire cytoplasm is enclosed within a cell membrane made of lipids and proteins. Its primary function is to selectively prohibit or permit the passage of substances into and out of the cell.

relationship of DNA molecules, genes, and chromosomes is shown in Figure 5.2. The sequence of genes in the chromosome characterizes a particular chromosome. Two categories of cells - namely, germ cells (reproductive cells such as oocytes and spermatozoa) and somatic cells (all other cells) - are based on the number of chromosomes they contain. Whereas germ cells contain n number of individual chromosomes, somatic cells contain $2n$ number of chromosomes in pairs, where n varies with species of the animal. In humans, n is equal to 23; therefore, there are 23 chromosomes in germ cells and 46 chromosomes in somatic cells.

In the cytoplasm of the cell exist four important organelles—ribosomes, endoplasmic reticula, mitochondria, and lysosomes - that carry out the cellular metabolic activities. Ribosomes are made up of protein and ribonucleic acid (RNA) and are responsible for protein synthesis in living matter. Endoplasmic reticula are tubular structures mostly responsible for protein synthesis. Mitochondria are ellipsoidal structures with a central cavity and contain specific enzymes to oxidize carbohydrate and lipid to produce energy. Lysosomes are small organelles in the cytoplasm that contain enzymes capable of lysing many nutrients and cells.

The growth of living matter is caused by proliferation of cells by cell division—a process in which a cell divides into two cells. The cell division of somatic cells is called *mitosis* and that of germ cells is called *meiosis*. Both mitosis and meiosis, designated as M, consist of four phases: *prophase*, *metaphase*, *anaphase*, and *telophase*. Each of these phases involves the rearrangement of the number of chromosomes and represents the progression of cell division (Fig. 5.3) and is described below.

In prophase, the chromosome thickens in the shape of dumbbell with a constriction at the center, called centromere. The nuclear membrane breaks open, leading to the mixture of cytoplasm and nuclear material, and spindles made of fibers are formed extending from one end (pole) of the cell to the other. Next in the metaphase, the chromosomes move to and line up at the central (or equatorial) plane of the cell, and the centromeres divide into two, each attaching to the spindle. Anaphase then follows and two chromatids move to the two poles of the cell. The last step of cell division involves the deconvolution of the chromosomes leading to the regeneration of the nuclear membrane and nucleoli around both poles. Division of cytoplasm (cytokinesis) sets in, and ultimately two daughter cells are formed.

Before cell division, each cell undergoes a long period, termed *interphase*, in which DNA molecules are synthesized. In DNA synthesis, two new DNA molecules are produced from each DNA molecule, which are exact replicas of the original DNA molecule. This period of DNA synthesis is designated the “S” phase, which takes place around the middle of the interphase. The period between the telophase and the S phase is termed G₁, and the period between the S phase and the prophase is termed G₂ (Fig. 5.4). During the G₁ and G₂ periods, no functional activity related to cell division occurs. The period of the entire cell cycle including the M and S phases varies with the types of cells. The S phase normally is the longest and G₁ is the most variable phase in the cell cycle. The duplicate DNA molecules lead to two identical chromosomes during mitosis, which are termed sister chromatids.

One important difference between mitosis and meiosis is that in meiosis, for a given series of cell division, every alternate cell division skips DNA synthesis, thus keeping the number of chromosomes the same in germ cells.

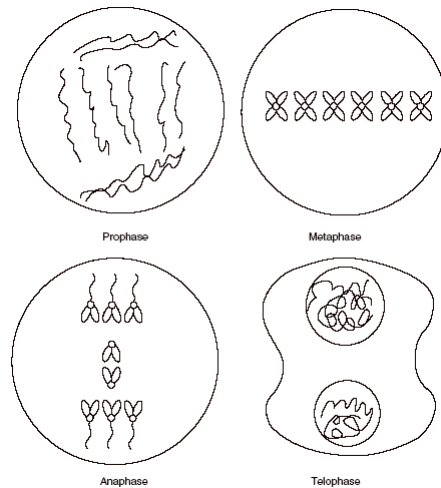

Fig. 5.3. Different phases of mitosis. See text for details.

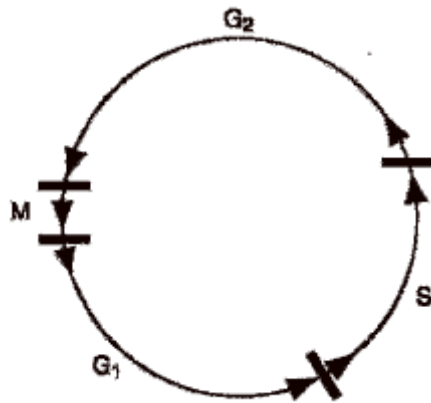

Fig. 5.4. The cell cycle. S is the DNA synthesis phase. M is the period of mitosis during which the prophase, metaphase, anaphase, and telophase take place. G₁ is the period between the telophase and S, and G₂ is the period between S and the prophase.

5.2. Effects of Radiation

5.2.1. DNA Molecule

The nucleus of the cell is the part most sensitive to radiation and this sensitivity has been attributed to the DNA molecule. To understand the effect of radiation on the DNA molecule, a knowledge of its structure is essential. It has a double-helical structure consisting of two strands, which are like the two rails of a ladder (Fig. 5.5A). The strands are composed of sugars interlinked by phosphate bonds. The two strands are connected to each other by rungs made of four bases: thymine (T), adenine (A), guanine (G), and cytosine (C) (Fig. 5.5B). The bases are bonded to the sugar molecule on the strands on both sides, and are paired to each other by hydrogen bonds. These four bases are arranged in a very specific manner to form a specific gene in every living species and provide the unique characteristics to these species.

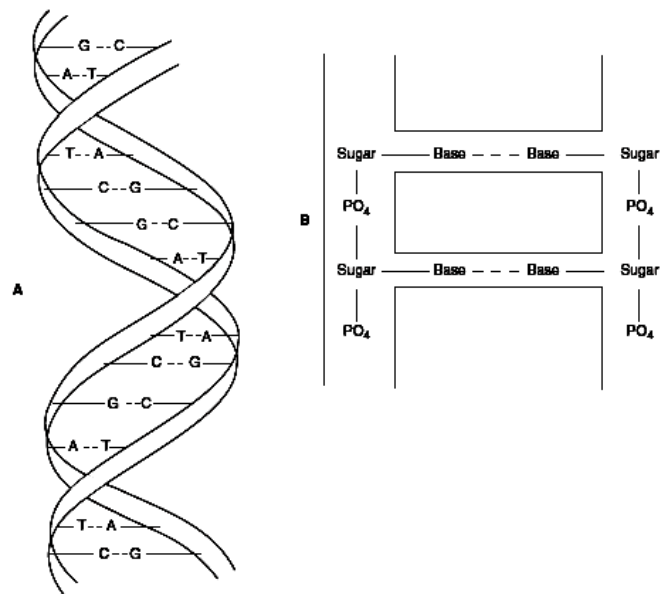

Fig. 5.5. **A.** Double-helical structure of DNA molecule composed of four bases: adenine (A), guanine (G), thymine (T), and cytosine (C). **B.** Configuration of a DNA molecule: strands are formed by sugar molecules bonded by phosphate groups. The rungs of the ladderlike structure are formed by bases connected to each other by the hydrogen band (dashed line) and to the sugar molecule on the strands on both sides.

Radiation damage to the DNA molecule can be due to

- (a) Loss of a base
- (b) Cleavage of the hydrogen bond between bases
- (c) Breakage of one strand of the DNA molecule (single strand)
- (d) Breakage of both strands of the DNA molecule (double strand)

These radiation effects on DNA molecules are illustrated in Figure 5.6. These changes result in so-called *mutations*, which have adverse effects on the genetic codes. The number of mutations increases with increasing radiation exposure. At low-dose exposures, the breaks are single stranded and can be repaired by joining the broken components in the original order. At higher exposures, however, double strand breaks occur and the odds for repair decrease. Also, high-LET radiations cause more damage to the DNA molecule because of the double strand breaks. If the cell is not repaired, it may suffer a minor functional impairment or a major consequence (cell death). If DNA damage occurs in germ cells, future offspring may be affected.

5.2.2. Chromosome

Chromosomes are likely to be affected by mutations of the DNA molecules. However, chromosomes themselves can be cleaved by radiation producing single or double breaks in the arms. These structural changes are called *aberrations*, anomalies, or lesions. These aberrations are categorized as chromatid aberrations and chromosome aberrations. In chromatid aberrations, irradiation occurs after DNA synthesis prior to mitosis and thus only one chromatid will be affected. On the other hand, in chromosome aberrations, irradiation occurs after mitosis prior to DNA synthesis and hence the broken chromatids will be duplicated producing daughter cells with damaged chromosomes.

Whether chromosome aberrations are induced by single-strand breaks or double-strand breaks in the structure determines the fate of the cell. In single-strand breaks, the chromosome tends to repair by joining the two fragments in a process called *restitution*, provided sufficient time is allowed. The cell becomes

functionally normal and replicates normally (Fig. 5.7A). However, if the fragments are replicated during DNA synthesis prior to restitution, two strands with centromeres and two strands without centromeres will be produced. Random combination of these fragments will then produce acentric and dicentric chromatids as illustrated in Figure 5.7B. Such chromosomes suffer severe consequences due to the mismatch of genetic information.

If radiation produces single-strand breaks in two separate chromosomes, then there are four ways of recombining the broken ends as shown in Figure 5.8. The dicentric and acentric combinations (Fig. 5.8A) are similar to those formed after replication of single strands in the same chromosome shown in Figure 5.7B. However, these cells suffer severe consequences because of the mismatch of genetic information from two separate damaged chromosomes. The translocation is a process in which two fragments—one with a centromere from one chromosome and one without a centromere from another chromosome—combine to form a new chromosome (Fig. 5.8B).

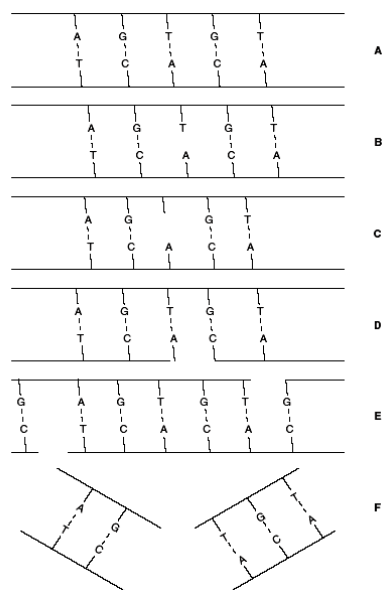

Fig. 5.6. Illustration of radiation effects on DNA molecules: (A) Normal DNA molecule; (B) hydrogen bond is broken without the loss of the base; (C)

hydrogen bond is broken with the loss of the base T; **(D)** single strand break that can repair; **(E)** double strand breaks which are well separated and can repair; **(F)** double strand breaks that are too close to repair.

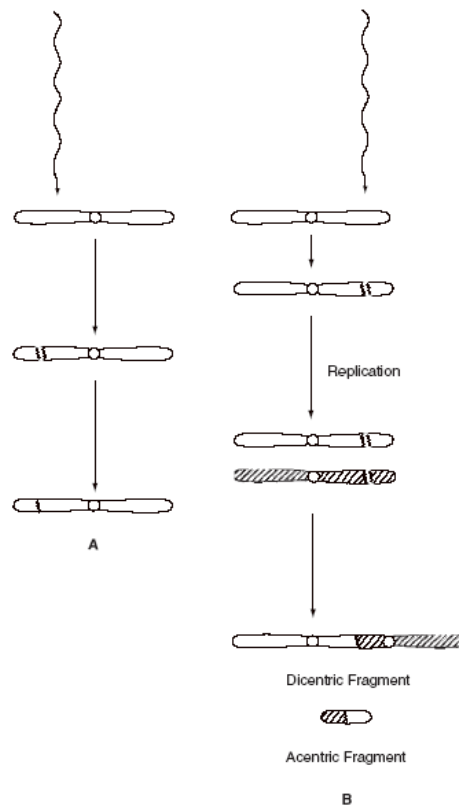

Fig. 5.7. **(A)** Illustration of restitution, in which the fragments produced by a single-strand break in one arm of the chromosome by radiation join together to produce the original chromosome. **(B)** Formation of dicentric and acentric chromosomes by combination of the fragments, after replication from a single-strand break in a chromosome.

In another scenario, radiation can cause two breaks in one arm of a chromosome, resulting in three fragments, only two of which combine with the loss of the third. Such a process is called deletion (Fig. 5.9A). Translocation and deletion, although not as harmful to the cell, cause late effects such as carcinogenesis and hereditary effects due to mismatch or loss of genetic material. An alternative to deletion is the combination of all three fragments into a chromosome with changes along the broken line as shown in Figure 5.9B.

This process is called inversion, which has all the original genetic material except a change in the sequence of genes and hence is not as detrimental to the cell.

Repair of chromosomes after irradiation depends on the sites of break in the DNA molecule or the chromosome, the total radiation dose, the dose rate, and the LET of the radiation. Chromosome aberrations by double-strand breaks occur more frequently at high-dose rates than at low-dose rates because of less time to repair and fewer chances of combining

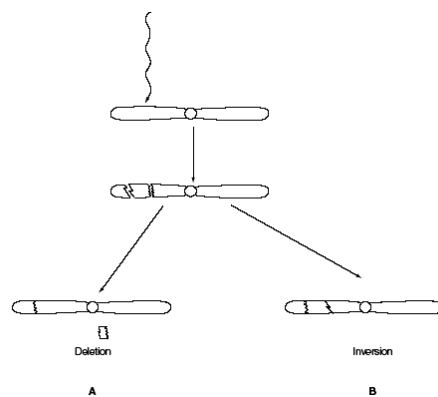

Fig. 5.8. Single-strand breaks in one arm of each of two separate chromosomes. Combination of these four fragments leads to dicentric and acentric chromosomes (A) or translocation (B).

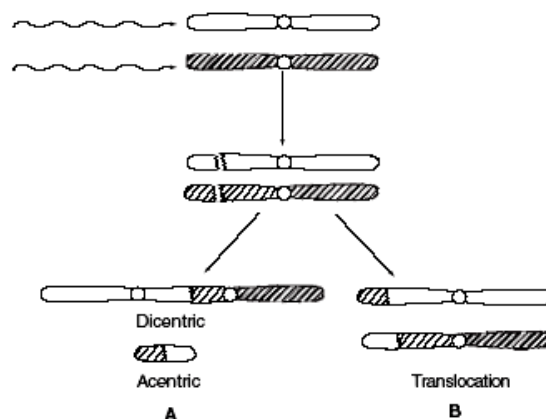

Fig. 5.9. Two breaks in one arm of a chromosome producing three fragments. (A) In deletion, two of the fragments combine with the loss of the third, or (B) in inversion, all three fragments combine with the interchange of positions.

two fragments in correct sequence of genes. High-LET radiations cause more double-strand breaks in chromosomes than low-LET radiations, and thus repair becomes difficult. For example, α -particles, protons, and neutrons will cause more chromosome aberrations than γ -rays.

5.2.3. Direct and Indirect Actions of Radiation

The DNA molecule of a cell is the most sensitive target to radiation. Radiation damage to the cell can be caused by the direct or indirect action of radiation on the DNA molecules. In the direct action, the radiation hits the DNA molecule directly, disrupting the molecular structure (Fig.5.10). The structural change leads to cell damage or even cell death. Damaged cells that survive may later induce carcinogenesis or other abnormalities. This process becomes predominant with high-LET radiations such as α -particles and neutrons, and high radiation doses.

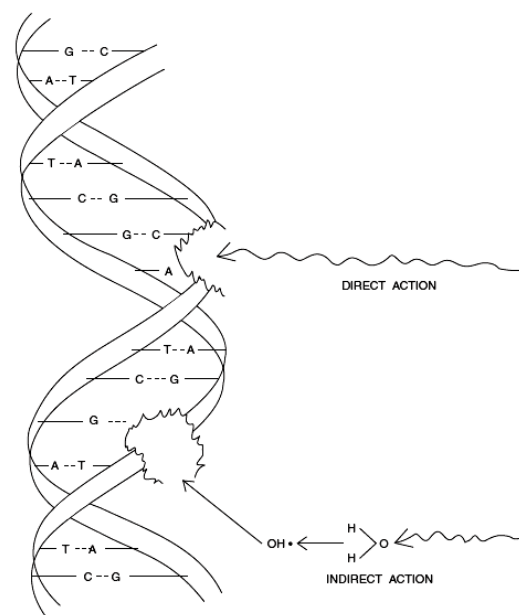
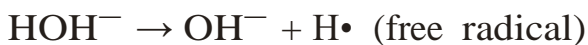
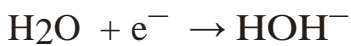
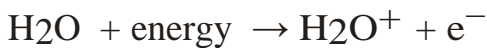

Fig. 5.10. Illustration of direct and indirect action of radiation on the DNA molecule. In direct action, radiations hit the DNA structure directly, whereas in indirect action, radiations produce free radicals in the cytoplasm, which react adversely with the DNA molecule to cause structural damage.

In the indirect action, the radiation hits the water molecules, the major

constituent of the cell, and other organic molecules in the cell, whereby free radicals such as perhydroxyl ($\text{HO}_2\bullet$) and alkoxy ($\text{RO}_2\bullet$) are produced. A variety of reactions that can occur after radiation interacts with water molecules is shown below.



Free radicals are characterized by an unpaired electron in the structure, which is very reactive, and therefore reacts with DNA molecules to cause a molecular structural damage (Fig. 5.10). Hydrogen peroxide, H_2O_2 , is also toxic to the DNA molecule. The result of indirect action of radiation on DNA molecules is the impairment of function or death of the cell. The number of free radicals produced by ionizing radiation depends on the total dose but not on the dose rate. It has been found that the majority of radiation-induced damage results from the indirect action mechanism because water constitutes nearly 70% of the composition of the cell.

5.2.4. Radiosensitivity of Cells

In living matter, there are two types of cells: differentiated and undifferentiated. Undifferentiated cells do not have any specific physiologic function except to develop into mature cells. They undergo mitosis and serve as the precursors for mature cells. In contrast, all mature cells are differentiated and perform specific

functions in the living body. For example, red blood cells (RBCs) are mature and differentiated cells performing the function of oxygen carriers, whereas erythroblasts are undifferentiated cells that develop into RBCs through mitosis.

According to the law of Bergonié and Tribondeau, undifferentiated cells that are undergoing active mitosis are most sensitive to radiation, and differentiated or mature cells are least affected by radiation. For example, in a sample of mixed RBCs, erythroblasts are most damaged and mature RBCs are least affected by radiation. Undifferentiated cells that are killed by radiation may be replaced by new cells, but those that survive with defective DNAs can induce late effects, such as cancer. In contrast, the S phase of DNA synthesis in the cell cycle is least radiosensitive. Radiosensitivity is best assessed by cell death. For differentiated cells, it means loss of cellular function, whereas for undifferentiated cells it means loss of reproductivity.

Groups of cells and their relative radiosensitivity are listed in Table 5.1. As can be seen, lymphocytes, though mature cells, are most sensitive to radiation, owing to a large nucleus; nuclear material is more radiosensitive. Nerve cells and muscle cells are totally differentiated cells and therefore

Table 5.1. Different types of cells and their radiosensitivity.

Types of cells*		Radiosensitivity
VIM	Mature lymphocytes Erythroblasts Spermatogonia	Highly sensitive
DIM	Myelocytes Intestinal crypt cells Basal cells of	Relatively
MCT	Osteoblasts Spermatocytes Chondroblasts Endothelial cells	Intermediate
RPM	Spermatozoa Granulocytes Erythrocytes Osteocytes	Relatively resistant
FPM	Nerve cells Muscle cells Fibrocytes	Highly resistant

Adapted from Casarett AP. *Radiation Biology*. Englewood

Cliffs, NJ: Prentice-Hall; 1968:168–169.

* VIM-vegetative intermitotic; DIM-Differentiating inter- mitotic; MCT-multipotential connective tissue;

RPM- reverting postmitotic; FPM-fixed postmitotic.

are highly resistant to radiation. The tissue or organ that contains more radiosensitive cells will be highly radiosensitive and vice versa. For example, bone marrow containing radiosensitive erythroblasts is very radiosensitive, whereas nerves and muscles containing radioresistant cells are less radiosensitive. Following irradiation of blood, depressed blood counts are observed as follows: lymphocytes on the same day, granulocytes in 3 days, platelets in 6 days, and RBCs in 10 days.

5.2.5. Cell Survival Curves

When mammalian cells are irradiated, not all cells are affected to the same extent. Different factors such as the total dose, the dose rate, the LET of the radiation, the particular stage of the cell cycle (M, G₁, S, or G₂) and the type of cell will affect the radiation-induced damage. Some cells may die and some will survive. The cellular response to radiation is illustrated by what is called the *cell survival curve*. It is obtained by plotting the dose along the linear X-axis and the surviving fraction along the logarithmic Y-axis. Surviving cells are those cells that retain all reproductive as well as functional activities after irradiation, whereas the death of cells is indicated by the loss of their function in differentiated cells and by the loss of reproductive activity in undifferentiated cells. It should be noted that thousands of grays are needed to kill differentiated cells, whereas only hundreds of grays are needed for undifferentiated cells.

Typical cell survival curves are shown in Figure 5.11. For high-LET radiations such as α -particles and low-energy neutrons, the survival curves are nearly a straight line starting from the lowest doses. In contrast, for low-LET radiations (e.g., x- and γ -radiations), the survival curve exhibits an initial shoulder, followed by a straight line. This straight line portion on the semilog plot is an exponential curve on a linear plot. This curve based on a *multitarget model* is characterized by three parameters: D_0 (dose at which 37% of cells survive),

the extrapolation number n , and the quasithreshold dose D_q , and they are related by the expression

$$\log_e n = D_q/D_0 \quad (5.1)$$

The quasithreshold dose, D_q , is the dose given by the width of the shoulder of the curve. The D_q indicates that, at low doses, almost all cells repair after irradiation, and cell killing is minimal, which is due to very limited radiation damage to the cell.

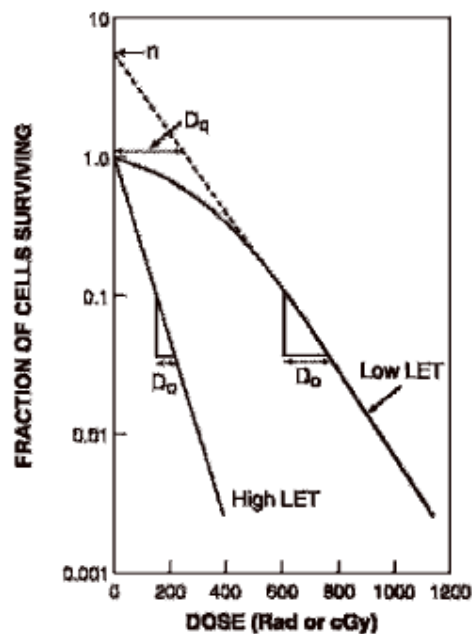

Fig. 5.11. Typical cell survival curves. The cell survival curve for low linear energy transfer (LET) radiations shows a shoulder of width D_q , which is called the quasithreshold dose. After D_q , the plot becomes linear on a semilog scale, indicating an exponential dose–response relationship. The extrapolation number n is obtained by extrapolating the linear portion of the curve back to the ordinate. D_0 is the dose obtained from the slope of the linear portion of the curve, at which 37% of the cells survive. The survival curve for high-LET radiations shows no or little shoulder, indicating D_q to be zero and n to be unity.

D_0 is determined from the slope of the straight line portion of the survival curve. It is the dose that kills 63% of the total number of cells. The value of D_0 is a measure of radiosensitivity of a given type of cell. For example, a

large value of D_0 for a type of cell means that the cells are less radiosensitive and vice versa.

The extrapolation number n is obtained by extrapolating the straight line portion of the survival curve back to the Y -axis. Its value depends on the width of the shoulder of the survival curve, that is, the quasithreshold value, D_q . Its value for mammalian cells varies between 1 and 10.

Although Eq. (5.1) has some merit in expressing cell killing by radiation, the *linear-quadratic model* provides a more accurate description of the radiation-induced cell killing. This model is mathematically expressed as

$$S = e^{-\alpha D - \beta D^2} \quad (5.2)$$

where S is the survival fraction of the cells irradiated with dose D and α and β are constants. For low-LET radiations, βD^2 is negligible at low doses, and the cell survival is proportional to the dose only, making the survival curve linear (Fig. 5.12). At higher doses, the cell survival is proportional to the square of the dose, and the curve tends to bend becoming concave downward (Fig. 5.12). For high-LET radiations, β is zero, and so the survival curve becomes linear.

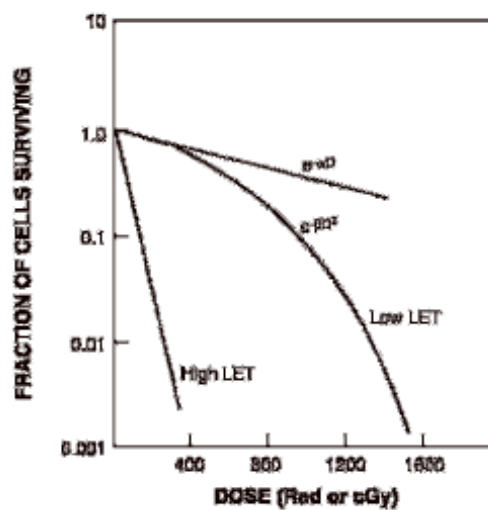

Fig. 5.12. Cell survival curves based on linear-quadratic model. The initial slope of the linear-logarithmic plot gives cell killing proportional to $e^{-\alpha D}$ and the

latter part to $e^{-\beta D^2}$ which bends at higher doses. With high-LET radiations, β is zero, and the curve is exponentially expressed simply by $e^{-\alpha D}$.

5.2.6. Factors Affecting Radiosensitivity

As already mentioned, various factors affect the radiation damage in the cell and hence the survival curve. The dose rate, the LET of the radiation, the presence of chemical molecules and the stage of the cell cycle all affect the survival curve.

5.2.7. Dose Rate

The dose rate, that is, the delivery of dose per unit time, is an important factor in cellular damage. The higher the rate of dose delivery, the greater will be the cell damage. At low-dose rates, only single-strand breaks of DNA molecules occur, and so cells have time to repair, whereas at high-dose rates double-strand breaks occur, and so repair is less likely to occur because of the shorter time available to the cells between ionizing events. Figure 5.13 illustrates the effects of two dose rates on the cell survival curve. The dose-rate effect is very important in radiation therapy, because unless an appropriate dose rate is prescribed, intended therapeutic effect may not be achieved. When a total dose is given to a patient in fractions over a period of time, it should be kept in mind that the interval between fractional doses should be short enough to keep repair of damage to abnormal cells to a minimum.

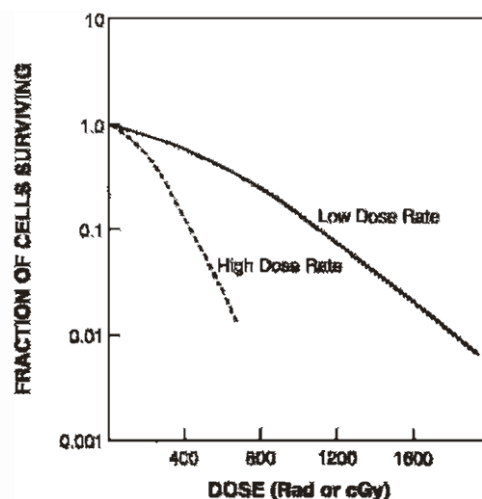

Fig. 5.13. The cell survival curves indicating the effect of dose rates. At high dose rates, the shoulder of the curve is reduced, with smaller values of D_q . The opposite is true at low dose rates.

5.2.8. Linear Energy Transfer

High-LET radiations do not exhibit a dose-rate effect on the survival curve. Also at high-dose rates (above 100 rad/min) of low- and moderate-LET radiations, no dose-rate effects are observed on the survival curve in contrast to low-dose rates. Thus, high-LET radiations exhibit no shoulder (i.e., no D_q) on the survival curve resulting in an extrapolation number of 1. High-LET radiations are densely ionizing radiations causing more double-strand breaks in the DNA molecules, and thus leading to more cell deaths than low-LET radiations, which are sparsely ionizing radiations. Radiation damage by high-LET radiations is so severe that the chances of repair are minimal, and even if repair takes place, the cell is likely to be defective.

5.2.9. Chemicals

Several chemicals, if present during irradiation, have been found to augment or diminish the effects of radiation on cells. Agents that enhance the cell response to radiation are called *radiosensitizers*, and those that protect cells from radiation-induced damage are called *radioprotectors*.

5.2.10. Radiosensitizers

Oxygen is the best-known sensitizer encountered in radiation biology. It has been found that hypoxic cells are very resistant to radiation, whereas oxygenated cells are highly radiosensitive. Such radiosensitization by oxygen is called the *oxygen effect* and is measured by a quantity called the *oxygen enhancement ratio* (OER). The OER is given by the ratio of the dose required to produce a given radiation damage to cells in the absence of oxygen to that required to produce the same damage in the presence of oxygen. The oxygen effect occurs only when oxygen is administered simultaneously with radiation.

It increases with O₂ tension up to 30 mm Hg, and remains constant at higher O₂ tension. For mammalian cells, the oxygen concentration required to produce a radiation response midway between hypoxic and aerobic conditions is approximately 0.5%. The OER value reaches a maximum of 3.0 for x- and γ -radiations, whereas it is about unity for high-LET radiations such as α -particles.

Figure 5.14 illustrates the effects of oxygen on the survival curve. The presence of oxygen makes the curve much steeper, indicating the augmentation of cellular damage at smaller doses relative to the situation of no oxygen. The mechanism of the oxygen effect is not clearly understood but is most likely related to DNA strand breaks. It has been postulated, however, that oxygen combines with already formed free radicals, R•, to produce peroxidyl group RO₂•, which is more damaging to the DNA molecules. While normally R• could recombine with complementary molecular components to repair the cell, RO• is an altered chemical entity and cannot help in cell repair. The oxygen effect is most predominant for γ - and x-rays, and is practically absent for high-LET radiations (e.g., α -particles). Because tumor cells are hypoxic, treatment of tumors with radiation under high-oxygen pressure has been advocated. It has been found experimentally that the proportion of hypoxic cells in a tumor remains the same before and after fractionated radiation therapy. Logically, radiotherapy should have killed more oxygenated cells and thus raised the proportion of hypoxic cells..

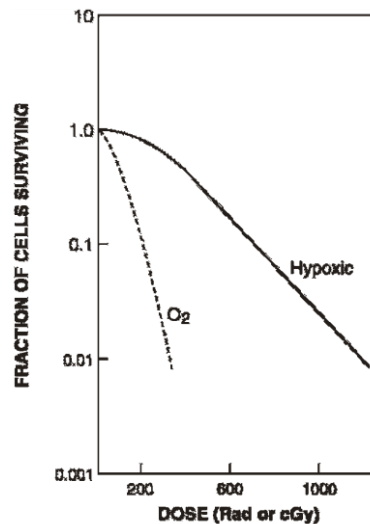

Fig. 5.14. The cell survival curve illustrating the effect of oxygen. In the presence of oxygen, the curve becomes steeper, indicating effective killing of the cells by radiation.

Instead, it remains the same and has brought in the argument of reoxygenation of the tumor cells during fractional radiation therapy, provided sufficient time is allowed for this to happen. This phenomenon has an important implication in radiation therapy in that even though the proportion of hypoxic cells remains the same, the total number of hypoxic tumor cells will be killed by radiation over time, thus leading to a successful treatment. The degree of reoxygenation varies with tumor types. The mechanism of reoxygenation has been attributed to the fact that as the tumor shrinks in size, surviving cells that were previously deprived of oxygen diffusion due to distal location of the blood vessels find themselves closer to the blood supply and so reoxygenate.

Halogenated pyrimidines such as 5-chlorodeoxyuridine (CIUDR), 5-bromodeoxyuridine (BUDR), and 5-iododeoxyuridine (IUDR) are useful radiosensitizers. When cells are treated with these drugs for several days before irradiation with x- or γ -rays, cells become highly sensitive to radiation. Potentiation of radiosensitivity is due to the fact that these drugs are similar to the DNA precursor thymidine, and therefore are incorporated into the DNA

molecule, making them more susceptible to damage by radiation. For optimal therapeutic gain in radiotherapy, patients should be treated for a period of time extending over several cell cycles to maximize drug incorporation into the cells.

5.2.11. Radioprotectors

The most common radioprotectors—substances that protect cells from radiation damage—include substances containing sulfhydryl groups (-SH), such as cysteine and cysteamine. These agents protect normal cells from radiation damage by combining with free radicals that are produced by radiation and would be toxic to normal cells. However, these compounds cause severe adverse reactions such as nausea and vomiting.

Less toxic compounds have been developed in which the -SH group is protected by a phosphate group. The phosphate group is hydrolyzed in vivo to release the -SH group for radioprotection. Two most effective compounds of this category are WR-638 and WR-2721 developed at Walter Reed Army Hospital, Washington, DC. Experimental evidence showed that these products concentrate more in normal cells and less in tumor cells. As a result, normal cells are protected better than tumor cells if these agents are administered immediately before the radiation dose is given. WR-2721, also called amifostine, is an aminothial and protects bone marrow. Its most common toxic effects are hypotension and somnolence. Radioprotectors are most effective with low-LET radiations, because they cause minimal damage.

5.3. Stage of Cell Cycle

Radiation damage mostly occurs during the period of mitosis, the M phase, whereas least damage occurs during the DNA synthesis, the S phase. Thus, the stage of the cell cycle determines the extent of radiation damage. Exposure of cells to 100 to 1000 rad (100 to 1000 cGy) causes delay in the G₂ phase to M phase transition. An exposure of 1000 rad (1000 cGy) inhibits the progression of the S phase cells by 30%, whereas the S phase to G₂ phase transition is not

affected by such an exposure (Prasad, 1995).

5.3.1. Classification of Radiation Damage

Cell death is a measure of extreme radiation damage. Therefore, based on the degree of lethality induced by radiation, radiation damage can be classified into three categories: (1) lethal damage, which causes irreversible death; (2) sublethal damage (SLD), which normally repairs in hours, and thus avoids cellular death, unless followed by another sublethal damage; and (3) potentially lethal dose (PLD), which can potentially kill the cell but can be modified to repair under specific physicochemical conditions. All these damages are relevant in clinical radiation therapy as to the effectiveness of treatment. Lethal damage is a definite end point in treatment, whereas SLD and PLD have variable effects in radiation therapy.

Sublethal damage occurs in mammalian cells, when a radiation dose is given in fractions at different time intervals rather than a single dose. There are four mechanisms, the so-called four R's that play a role in the SLD repair (SLDR) mechanism: repair, redistribution, regeneration, and reoxygenation. Repair involves the healing of the radiation-induced damage in the time interval between the two fractions of the dose. If the second dose is applied too soon after the first application, the damage does not have enough time to repair and the cell will die. In fractionated radiotherapy, normal tissues are spared by SLD because of its repair mechanism. In the redistribution process, the cells are desynchronized and sensitized to show increased damage. Following irradiation, the radiosensitive cells will die, and one would expect the proportion of radioresistant cells and hence the surviving fraction to increase. In fact, however, the surviving cells become sensitized and tend to die. This result depends on the fractionated dose and the time interval between the doses. Regeneration is a mechanism of response to depopulation of a cell cohort due to radiation damage, and depends on the types of tissue and their proliferating capacity. Protracting a fractionated dose should be beneficial to normal tissues and somewhat harmful to regenerating tumor cells. Reoxygenation discussed earlier

is an effect that makes the hypoxic cells more radiosensitive in the presence of oxygen in fractionated radiotherapy.

Sublethal damage repair depends very much on the dose rate and in which stage of the cell cycles the cells are. At lower doses, more SLD can be repaired, and at higher doses, the chances of SLD repair diminish. The dose-rate effect varies with the types of tissue and species. For example, the testis of male rats is most radiosensitive, whereas the small intestine seems to be less affected by radiation. Also, SLD repair depends on the LET of radiations. The repair is significant with x-rays and γ -rays and almost nonexistent for neutrons and α -particles. SLD repair is very important in radiation therapy as it provides maximum survival of normal cells, while killing tumor cells.

Potentially lethal damage after a single dose of radiation can potentially kill the cell but it can be repaired (PLDR) under specific physicochemical conditions. For example, the survival of the HeLa cells increased after irradiation, when the cells were treated with excess thymidine or hydroxyurea for a period of 4 hr. However, opposite results were obtained by other investigators. The importance of PLDR in radiotherapy is a matter of debate.

PLDR and SLDR are found with low-LET radiations (e.g., γ -rays and x-rays giving cell survival curves with a broad shoulder), while they are absent for high-LET radiations (neutrons and α -particles).

5.4. Stochastic and Deterministic Effects

Two categories of radiation effects on biological systems are encountered: stochastic and deterministic. Stochastic effects are the biological effects that occur randomly, the probability of which increases with increasing dose without a threshold. Radiation-induced hereditary effects and cancer incidences are examples of stochastic effects. The assumption of no threshold is made on the belief that radiation damage to a few cells or a single cell could theoretically induce the genetic disorder or cancer, and the severity of the disease will be the same, if it ever occurs. It should be noted that the basic principle of ALARA (as

low as reasonably achievable) in Nuclear Regulatory Commission (NRC) regulations is based on the assumption of risks linearly proportional to the dose without a threshold. Much debate is currently going on regarding the assumption of the linear-no-threshold (LNT) theory (discussed below).

The deterministic or nonstochastic effects are induced by high radiation doses and the severity of the damages, rather than their probability of occurrence, increases with the dose. These effects have a threshold dose below which no damage is evident. Cataracts, skin erythema, sterility, and fibrosis are examples of deterministic effects induced by high radiation doses.

5.4.1. Acute Effects of Total Body Irradiation

Different tissues of the body respond differently to radiation, due to varying degrees of radiosensitivity. When an adult subject is irradiated over the entire body, various syndromes are manifested depending on the dose applied. The effects of radiation are characterized by the survival time of the species and various stages of acute syndromes following the total-body irradiation. These effects are deterministic types and have a threshold dose.

Cell survival time varies with mammal species depending on the individual radiosensitivity. The radiosensitivity of a given species is commonly characterized by the lethal dose, LD_{50/60}, which is the dose that kills 50% of the species in 60 days. The LD_{50/60} for humans is 400 to 600 rad (400 to 600 cGy); for dogs, 300 rad (300 cGy); and for mice, 900 rad (900 cGy).

Acute radiation syndromes appear in four stages: prodromal, latent, manifest illness, and recovery or death. Each stage is dose dependent and can last for a few minutes to weeks. A minimum of 200 to 300 rad (200 to 300 cGy) is required for all four stages to be seen and can cause death.

In the prodromal stage, major symptoms are nausea, vomiting, and diarrhea and they occur in the early phase, lasting for only a short period of time depending on the dose. A dose of 50 rad can induce nausea and vomiting. In the latent stage, biological damage slowly builds up without

manifestation of any syndromes, again lasting for hours to weeks, depending on the dose. During the manifest illness stage, radiation syndromes appear as a result of the damage to the organs involved after the latent period, and the subject becomes ill. In the last stage, the subject either recovers or dies.

There are three categories of syndromes in the manifest illness stage depending on the dose: hemopoietic or bone marrow, gastrointestinal (GI), and cerebrovascular.

5.4.2. Hemopoietic Syndrome

Hemopoietic or bone marrow syndromes appear at a total body dose of 250 to 500 rad (250 to 500 cGy) following irradiation. At this dose, the precursors for RBCs and white blood cells (WBCs) are greatly affected, so much so that they lose the ability to reproduce. Also, the number of lymphocytes are greatly depressed, whereby the immune system of the body is suppressed. Loss of blood cell counts can be noticed at a dose as low as 10 to 15 rad (10 to 15 cGy). Thus, the body loses the defense against bacterial and viral infection and becomes susceptible to them. Immunosuppression by radiation occurs at doses as low as 100 rad (100 cGy) and 90% to 95% of immunosuppression can take place in humans at doses of 200 to 400 rad (200 to 400 cGy).

At this dose level, the platelet count is drastically reduced, and therefore bleeding gradually progresses through various orifices owing to a lack of ability of the blood to coagulate. Fever, bleeding, and infection result, followed by ultimate death in 10 to 21 days. However, bone marrow transplantation at the appropriate time may prompt the recovery of the subject. Whereas at doses <100 rad (100 cGy) survival is almost certain, survival is virtually impossible at doses >500 rad (500 cGy).

5.4.3. Gastrointestinal Syndrome

Gastrointestinal (GI) syndromes are expressed at a total body dose of 500 to 1000 rad (500 to 1000 cGy) and include prodromal syndromes such as nausea,

vomiting, and diarrhea of more severity that appear within hours after exposure. The primary effect of radiation exposure in this range is that the intestinal crypt cells are destroyed and not replaced, and consequently the mucosal lining (villi) shrinks and hardens whereby the gut becomes nonfunctional. Because of the denudation of the gut, an intestinal ulcer may develop. These GI syndromes are also accompanied by drastic hemopoietic syndromes including immunosuppression, loss of white blood cells, and infection.

Thus, the loss of nutrients through ulcers, in combination with bacterial infection and excessive bleeding, results in GI death in 3 to 10 days after radiation exposure. Only aggressive medical treatment in the early stages of exposure may lead to recovery in cases at the lower end of the dose spectrum.

5.4.4. Cerebrovascular Syndrome

Cerebrovascular syndromes appear in a matter of minutes after radiation exposure at a total body dose of more than 10,000 rad (10,000 cGy). Because the nerve cells are radioresistant, such a large dose is required for cerebrovascular syndromes to appear. The symptoms include severe nausea, vomiting, and burning sensation of the skin that occurs within minutes of exposure, followed by the malfunction of the neuron motor pump giving rise to motor incoordination, intermittent stupor, coma, and ultimately death in two to three days. The cerebrovascular death sequence is so rapid that there is little time for significant changes to appear in other organs in the body. At this level of radiation dose, death is a certainty and medical help is of no use.

5.4.5. Long-Term Effects of Radiation

The long-term or late effects of radiation cause various syndromes long after the radiation exposure. These may appear after acute radiation syndromes subside following exposure to a single large dose or after exposure to many

smaller doses over a period. The late effects may be somatic or genetic, depending on the respective cells involved. Somatic effects are seen in the form of carcinogenesis, life-shortening, cataractogenesis, and embryo-logic damage. On the other hand, genetic effects result in abnormalities in the offspring.

5.4.6. Somatic Effects

5.4.6.1. Carcinogenesis

Cancer develops in three stages: initiation, promotion, and progression. Initiation of cancer is caused by various agents such as chemicals, ultraviolet rays, radiation, and viruses. In the case of radiation, cancer is initiated by the action of radiation on the DNA molecule resulting in the mutation of the cell. Cancer promoters are those agents that cannot initiate the cancer but simply promote it once it is started. Examples of tumor promoters are estrogen, phorbol ester, excessive fat, and radiation. Radiation acts as a promoter by inactivating tumor suppressive genes through the interaction of the free radicals produced in the cytoplasm by radiation. In these two stages, mutated cells proliferate at the site of cancer growth. One or more of these cells become aggressive and are likely to spread to other organs. This stage is called the progression or metastasis of the cancer.

At the cellular level, carcinogenesis is thought to be controlled by two types of genes: oncogenes and suppressor genes. There is evidence that oncogenes are responsible for the growth and proliferation of tumor cells, while suppressor genes inhibit the tumor cell growth. Most oncogenes have their counterpart, proto-oncogenes in normal cells, that are present throughout their eukaryotic evolution. Radiation or other carcinogens activate normal proto-oncogenes to several cancer-causing oncogenes and inactivate suppressor genes, resulting in cell proliferation to cause cancer. Chromosome aberrations (deletion or translocation) caused by radiation are responsible for oncogene activation. There are about 100 oncogenes identified that are associated with various human cancers. For example, deletion of a part of the

chromosome is responsible for the activation of *N-ras* oncogene associated with neuroblastoma. Similarly, a translocation between chromosomes 8 and 14 in humans activates the *C-myc* oncogene in B-cell lymphoma.

Suppressor genes exist in normal cells to control the cell growth and protect the genome against carcinogenic agents. After radiation damage, suppressor genes stop cell division and repair the damaged gene. Examples of suppressor genes include the p53 gene found in breast cancer, small cell lung cancer, and bladder cancer; the DCC gene in colon cancer; and the p105 Rb gene in retinoblastoma. Radiation can inactivate these suppressor genes and thus cause cell proliferation leading to malignancy.

5.4.6.2. Epidemiologic Evidence of Carcinogenesis

The latent period of malignancies varies with the type of malignancy and the absorbed dose. Leukemia has an average latent period of about 5 to 10 years, whereas solid tumors in the head, neck, pharynx, and thyroid have a minimum latent period of 10 years with an average of 20 to 30 years.

Malignancies have been observed in individuals who are exposed to radiation from medical treatment, radiation-related occupation (e.g., industrial exposure), and acts of war. Infants and children are more radiosensitive than adults, and the risk of cancer from radiation exposure in the former is greater than that in the latter, almost by a factor of 2.

In the early 1900s, radium-dial painters used to lick the brush bristle soaked with radium-containing paint to make a fine point for painting clock and watch dials. During the procedure, they ingested radium, which, as a chemical analog of calcium, localized in bone, causing bone tumors. In some cases, the quantity of radium ingested was large, and acute effects including death were observed.

Before the 1930s, the enlarged thymus gland of infants with acute respiratory distress syndromes was commonly treated with therapeutic doses of x-rays to reduce the enlargement. During irradiation, however, the thyroid glands also

received a massive radiation dose. A statistically significant number of these infants developed thyroid cancer later in life (about 10 years later).

Radiologists who used x-rays in their profession were found to have a higher incidence of leukemia than other medical professionals. Dentists had higher incidence of finger lesions due to exposure to dental x-rays. These incidences occurred mostly before the 1950s, largely because of the lack of knowledge of radiation effects. Now, through better radiation protection practice, these incidences have been curtailed drastically.

From 1935 to 1944, approximately 15,000 patients with ankylosing spondylitis were irradiated with 100 to 2000 R over spine and pelvis. A 2-year follow-up showed an increased incidence of leukemia in this group of patients.

Increased incidences of leukemia, lung cancer, breast cancer, and thyroid cancer have been observed in the Japanese survivors of the atomic bomb attacks on Hiroshima and Nagasaki.

Uranium mine workers inhale a considerable amount of radioactive dust containing radon gas. The decay products of radon settle in the lungs, and radiations from them can cause lung cancer.

5.4.7. Dose–Response Relationship

A meaningful dose–response relationship for carcinogenesis should be based on data with both low and high radiation exposures. However, the low-dose data (below 10 rad or 10 cGy) that have been accumulated thus far are mostly inconclusive, because of the small sample size, lack of appropriate control, incomplete dosimetry, and other related factors. So risks at low doses are primarily estimated by extrapolation of the data from high-dose experiments. Several authoritative committees (international and national) are responsible for establishing the dose-response relationship, and they are the United Nations Scientific Committee of the Effects of Atomic Radiations (UNSCEAR), the Committee on the Biological Effects of Ionizing Radiations (BEIR), the International Commission on Radiological Protection (ICRP),

and the National Council on Radiation Protection and Measurements (NCRP) in the United States. These committees base their analysis on the data of the Japanese survivors of the A-bomb attacks on Hiroshima and Nagasaki, data on human exposures mentioned above (see Epidemiologic Evidence of Carcinogenesis), and data from in vitro cell culture and animal studies.

The risk versus dose relationship has been controversial, particularly about the minimum level of radiation dose that induces cancer (Murphy, 1991). Some experts propose that the dose–response relationship is linear, without a threshold dose, and that a very minimal dose can cause cancer (Fig. 5.15). A threshold dose is a dose below which no radiation damage occurs in an individual. The LNT dose–response relationship has been based on the extrapolation of high-dose data to low-dose data (below 10 rad or cGy) and has drawn a considerable debate as to its validity. In one argument, the opponents of the theory question the validity of such extrapolation, because the mechanism of radiation damage may be quite different at doses that differ by orders of magnitude. Also, this group points out that the people living in high natural background radiation areas (e.g., Rocky Mountains) do not show to have any more apparent adverse health effects than those in low-dose areas (e.g., sea level). On the other hand, the proponents of the LNT theory suggest that a single hit by a radiation can cause the mutation of a cell, and consequently result in carcinogenesis in a later period, thus supporting the theory. The recent BEIR VII report strongly supports the LNT theory, suggesting that even the smallest dose can cause a small risk of cancer in humans.

All intermediate and high-energy data primarily obtained from the Japanese survivors of the A-bomb attacks are fitted by a linear quadratic curve (Fig. 5.15). The curve is linear at lower doses and becomes proportional to D^2 (quadratic) at higher doses. Yet, other experts believe that there is no risk of carcinogenesis up to a certain threshold dose, after which the curve becomes linear or quadratic (Fig. 5.15). While the linear response model is preferred for all solid tumors, the linear-quadratic model is more suitable for leukemia.

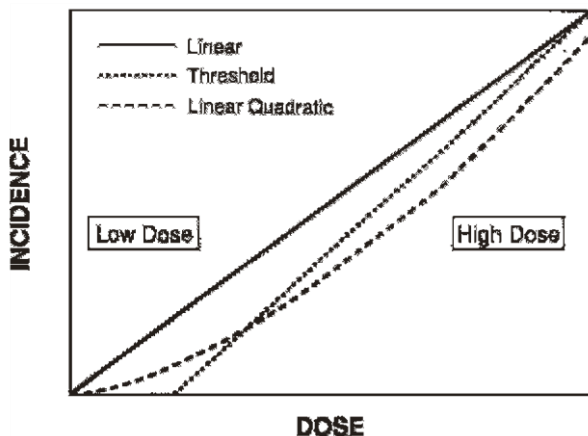

Fig. 5.15. Three general shapes of the dose–response curves permit prediction of different incidences of low-dose radiation effects when the curves are fitted to high-dose data. (Adapted from Murphy PH. *Acceptable risk as a basis for regulation. Radiographics* 1991; 11:889–897.)

5.4.7.1. Risk Estimates of Excess Cancer

The BETR VII Committee (2005) estimated the excess cancer risk based on the LNT theory and by extrapolation of high-dose incidences to the low-dose situations. It is estimated that 1 in 100 individuals is expected to develop solid tumor or leukemia from a radiation dose of 10 rem (0.1 Sv), whereas approximately 42 of these 100 persons are expected to develop these cancers from other causes. Lower doses would produce proportionally lower risks. So, approximately 1 in 1000 individuals would expect to develop cancer from an exposure of 1 rem (0.01 Sv). Another estimate of cancer risk by BETR VII is that 1 in 100 persons would likely develop cancer from a lifetime (70 yr) exposure to low-LET natural background radiations excluding radon and high-LET radiations. For comparison, the ICRP estimate of cancer risk for the general population is 0.1 per Sv (0.1% per rem) for high doses and dose rates, and 0.05 Sv (0.05% per rem) for low doses and dose rates (ICRP 60, 1991).

5.4.7.1.1. Leukemia

Leukemia is one of the most common cancers induced by radiation in humans, accounting for one in five mortalities from radiocarcinogenesis. Risk of leukemia varies with age, with younger persons being more prone

to radiocarcinogenesis than older persons. Based on a relative-risk linear quadratic dose response model, the BEIR V Committee (1990) predicts a risk of excess lifetime leukemia cancer mortality of 10 in 10,000 (0.1%) with an exposure of 10 rad (10 cGy). The BEIR VII (2005) estimate of this value is 1 to 2.6 per 10,000 person years per Gy (1 to 2.6 per 100 person years per rem). Leukemia appears in as early as 2 to 3 years after the exposure, with an average latent period of 5 to 10 years.

5.4.7.1.2. Breast Cancer

The annual incidence of breast cancer in women in the United States is 1 in 11, with a high mortality rate. Several factors—age, estrogen level, heredity, demographics, race, number of children given birth to, and breastfeeding—all influence the risk of breast cancer. Women exposed to low-level radiation can develop breast cancer, and the risk is greater with younger ages than with older ages. According to the BEIR V (1990) report, the excess absolute risk of breast cancer in 25-, 35-, and 45-year-old women is 5, 4, and 2 in 10,000, per Gy (5, 4, and 2 in 100 per rem) respectively. The BEIR VII (2005) estimate of this value is 10 per 10,000 person years per Gy (10 per 100 person years per rem) at age 50. The risk of radiogenic breast cancer apparently is reduced if the dose is given in divided exposures.

While in the past, the breast cancer risk from mammography was of major concern, modern mammographic equipment is well designed and properly shielded, resulting in significant reduction in radiation exposure and hence a lower risk of breast cancer. According to the recommendations of the American College of Radiology, women over 40 should have annual mammography screening for breast cancer.

5.4.7.1.3. Other Cancers

Radiation-induced cancers in the thyroid, lungs, bone, skin, and other organs have been found in the general population and are influenced by a variety of etiologic factors such as heredity, occupation, age, sex, and hormonal level. For

thyroid cancer, the BEIR VII (2005) reports the excess absolute risk of 4.4 per 10,000 person years per Gy (4.4 per 100 person years per rem).

5.4.7.2. Radiation Damage to Skin

The skin is sensitive to radiation because of the presence of highly radiosensitive structures such as hair follicles and sebaceous glands. The radiation effect on the skin is deterministic and has a threshold dose of about 100 rad (100 cGy). The primary skin reactions to radiation are erythema and dermatitis. Initial erythema appears in a few hours to a few days after radiation exposure, which is followed by dry desquamation characterized by atrophy of epidermal papillae and vascular changes. In the third or fourth week, erythema reappears with red, warm, edematous, and tender skin. Temporary hair loss (epilation) can occur at this stage. Severe erythema is followed by acute radiation dermatitis manifested by blister formation, dermal hypoplasia, edema, and permanent depilation. The normal skin reappears in 2 to 3 months.

The above effects depend on the dose, dose rate, LET of the radiation, and the duration of exposure, and vary from individual to individual and with the location in the same individual. Although sex is not a factor in skin reaction, age is an important factor, with the skin of younger people being more sensitive.

A low-level chronic exposure of radiation on the skin causes atrophy, hyperplasia, and hyperkeratosis. In addition, ulceration and deep fibrosis may result from such exposures. In rare instances, skin cancer, mainly squamous cell carcinoma, may develop.

5.4.7.3. Radiation Damage to Reproductive Organs

Extremely deleterious effects are expected from radiation exposure to the gonads, because of their high radiosensitivity. In males, spermatogonia are most radiosensitive, and spermatozoa and spermatids are radioresistant, whereas in females, the ovarian follicles are most radiosensitive. The radiation effects vary with the dose, dose rate, sex, and age.

Sterility is the important radiation effect that warrants special attention. In males, temporary sterility can be induced with a dose as low as 15 rad (15 cGy), whereas permanent sterility is reported with an acute dose of 500 to 600 rad (500 to 600 cGy) (Prasad, 1995). Male sterility is evident by a reduced sperm count and low motility. In females, permanent sterility occurs with 320 to 625 rad (320 to 625 cGy), which is manifested by the damage to the ovarian follicles. If the dose is lower, then the follicles may recover in 5 to 6 months. Relatively larger doses are needed in younger women than in older women.

5.4.7.4. Nonspecific Life-Shortening

Studies have shown that exposure to ionizing radiations results in the shortening of the life span of mice (Rotblat and Lindop, 1961). For acute total body exposure, the life span of mice, rats, and dogs is reduced by about 5% per gray (UNSCEAR, 1982). The irradiated group looks much older than the control group, and radiation effects are similar to those of normal aging, e.g., an increase in connective tissue and a decrease in parenchymal cells. During the period 1945-1955, American radiologists were found to have a shorter life-span than other medical professionals. But the issue of life-shortening by radiation is controversial, because in some cases it has been found that life span is rather lengthened by irradiation at low doses. Such observations have led to the concept of *hormesis*, which states that low doses of radiation are beneficial to health and prolong the life span. It is postulated that hormesis is secondary to an enhanced immune responsiveness due to radiation at low doses.

5.4.7.4.1. Cataractogenesis

The lens of the eye is sensitive to radiation and develops cataracts on irradiation with ionizing radiations. The incidence of radiation-induced cataracts is a deterministic effect and depends on the dose given. A dose of 10 to 30 rad (10 to 30 cGy) is required to produce cataracts in mice, whereas a threshold dose of about 200 rad (200 cGy) is needed to produce cataracts in humans in a single exposure. A larger dose is required if the dose is given in

fractions, and high-LET radiations almost double the incidence of cataractogenesis. A minimum of 1 year is needed for the latent period of cataractogenesis.

5.4.7.5. Radiation Damage to Embryo and Fetus

The developing mammalian embryo is extremely sensitive to ionizing radiations, because many cells are differentiating at this stage. The degree of damage depends on the developmental stage of the embryo, the dose, and the dose rate. The entire fetal development is divided into three general stages: (1) *preimplantation*, a period of about 8 to 10 days between fertilization of the egg and its attachment to the uterine wall; (2) *major organogenesis*, a period of about 2 to 6 weeks, when major organs are developed; and (3) the *fetal stage*, the remainder of the pregnancy period, when the organs of the fetus grow further to enable the mammal to survive after birth.

The embryo in the preimplantation stage is most sensitive to ionizing radiations and mostly encounters prenatal embryonic death as a result of radiation exposure. In some species, a dose as low as 5 to 15 rad (5 to 15 cGy) is sufficient to cause deleterious effects on the embryo. At a dose of 200 rad (200 cGy) in the preimplantation stage, embryonic death is certain. Almost all embryos that survive the radiation exposure grow normally in utero and afterward, with the exception of a few that develop abnormalities later.

During the period of major organogenesis, embryos exposed to ionizing radiations develop abnormalities mostly related to the central nervous system (CNS) and bone. These abnormalities are too severe for the fetus to survive and ultimately result in neonatal death. At an exposure of 200 rad (200 cGy) to mouse embryos during this period, almost 70% of the embryos later experienced neonatal death. Growth retardation also is noted at doses above 100 rad (100 cGy). Often it is suggested that a therapeutic abortion should be considered if an embryo receives ~10 rad (10 cGy) during the first 6 weeks after conception.

During the fetal period, however, comparable doses do not cause any abnormality or neonatal death, because fetal cells are more radioresistant than embryonic cells. Relatively higher doses are needed to cause death in this period. A few cases of growth retardation have been noted. In utero irradiation with a dose of 1 to 2 rad (1 to 2 cGy) may increase the risk of childhood leukemia in the first 10 to 15 years by a factor of 1.5 to 2. Mental retardation in this period has been reported with doses as low as 10 to 20 rad (10 to 20 cGy), if given in the 8 to 15 weeks of gestation.

Because of these radiation effects, radiological procedures are contraindicated in pregnant women, and practitioners must exercise caution in determining the woman's status of pregnancy before these procedures. Before a procedure, it is a common practice to inquire of the patient if she is pregnant or when she had her last menstrual period, and thus unnecessary fetal exposure can be avoided. If the patient is pregnant and the procedure is essential, then the risk versus benefit to the patient from the procedure should be weighed by the practitioner with due consideration to the stage of pregnancy.

5.4.8. Genetic Effects

As mentioned above, ionizing radiations can cause changes in the DNA structure, which ultimately are expressed in gene mutations. Through the affected germ cells, these mutations propagate to future generations. Genetic effects are not expressed in the individual whose germ cells have been affected by radiation, but are expressed in future generations. Genetic effects appear as Down syndromes, achondroplasia, retinoblastoma, cystic fibrosis, sickle cell anemia, Tay-Sachs disease, and other chromosome disorders.

5.4.8.1. Spontaneous Mutations

In normal cells, genes occasionally undergo natural mutations even without radiation exposure. Such mutations are called *spontaneous mutations*, and their frequency is about 10^{-5} per gene per generation. This means that the chance of spontaneous mutation is 1 in 100,000. This frequency is increased by various

mutagens such as chemicals and radiation.

In a given generation, radiation does not produce any new mutations and simply increases the frequency of spontaneous mutations. BEIR VII (2005) estimated the total risk for all classes of genetic diseases to be 3.0×10^{-5} to 4.7×10^{-5} per rem (3.0×10^{-3} to 4.7×10^{-3} per Sv) per generation. It indicates that the genetic risks are relatively small. The dose-response relationship is linear without threshold, indicating that no dose is safe and any dose, however relatively small. Furthermore, genetic damage is a function of the dose rate and the LET of ionizing radiations. High-LET radiations and high-dose rates cause more mutations. Genetic mutations may appear in future generations long after exposure has occurred.

5.4.8.2. Doubling Dose

The doubling dose is a measure of the increase in genetic mutations by radiation. It is the amount of radiation dose that doubles the spontaneous mutations in one generation in a species. It is calculated as a ratio of the average spontaneous and induced mutation rates in a set of genes. A small doubling dose indicates a large relative mutation risk and vice versa. In humans, it is considered to be of the order of 100 rad (100 cGy), but it depends on the dose rate, the gender, and the type of species (BEIR V, 1990). Based on this doubling dose, the ICRP has given an estimate of the probability of induced hereditary disorders to be 0.6×10^{-2} per sievert (0.6×10^{-4} per rem) for the working population (ICRP 60, 1991).

5.4.8.3. Genetically Significant Dose

The genetically significant dose (GSD) is the dose that, if received by everyone of the entire population, would cause the same genetic damage as the gonadal dose now being received by a limited number of individuals of the population through medical procedures, natural radiations, TV viewing, flying at high altitudes, and so forth. The GSD is an index of the expected genetic damage on the whole population, and is calculated as an average value from the gonadal

doses received from all exposures by the exposed personnel with proper weighting with respect to the chances of their having offspring. Thus, the GSD depends on the total number of individuals irradiated and the relative expectancy of their having children. The weighting factor is needed because older people have lesser probability of having offspring than younger people.

The contributions of various sources of radiation to GSD are given in Table 15.2. The GSD values from natural radiation sources are considered to be equal to the gonadal dose, because natural radiation exposes the entire population of all ages uniformly. Of all medical procedures, diagnostic x-rays contribute most to the GSD. It is, therefore, essential that strict protective measures are taken to avoid unnecessary gonadal exposure.

Table 5.2. Annual genetically significant dose (GSD) in the U.S. population about 1980–1982.

Source	Contributions to GSD in mrems (mSv)
Natural sources	
Radon	10 (0.1)
Other	90 (0.9)
Medical	
Diagnostic x-rays	20–30 (0.2–0.3)
Nuclear medicine	2 (0.02)
Consumer products	5 (0.05)
Occupational	~0.6 (0.006)
Nuclear fuel cycle	<0.05 (0.0005)
Miscellaneous environmental sources	<0.1 (0.001)
Total	~132 (1.32)

Adapted with permission from Table 8.2 in NCRP report No. 93, 1987.

Gonadal shields, appropriate collimation of the x-ray beams, and limited and prudent application of repeat procedures definitely lead to a considerable reduction in GSD from medical procedures.

Genetic effects of radiation can be greatly reduced if a time interval is allowed between radiation exposure and conception. This is the consequence of some repair process after irradiation. It is, therefore, recommended for both men and women that conception should be deferred for about 6 months after a significant radiation exposure such as a radiation accident or radiation

therapy involving high gonadal exposure. Such delay in conception is not needed for diagnostic procedures.

5.4.9. Risk Versus Benefit in Diagnostic Radiology and Nuclear Medicine

Millions of x-ray, dental x-ray, computed tomography (CT), and nuclear medicine procedures are performed in the United States for the diagnosis of diseases, and the number is increasing steadily over the years. However, with the remarkable improvement in the evolving techniques and equipment, the effective dose to the individual and to the population as a whole is steadily decreasing.

Of all diagnostic radiological procedures, CT scans and fluoroscopic procedures give the highest effective doses, whereas dental and chest x-rays contribute only minimal effective doses. Gonadal doses are higher with fluoroscopic procedures than with head CT, chest x-ray, and dental procedures. This is primarily due to the fact that the gonads are out of the field of the latter procedures. It should be noted that the mammographic procedure contributes only a little to the total body dose compared to the breast. For obvious reasons, the highest gonadal dose comes from the procedures involving hips and pelvis. The GSD is about 9.8 mrad (98 mGy) for males compared to 20.9 mrad (209 mGy) for females (NCRP 100, 1989).

The doses to different organs from different nuclear medicine procedures are listed in Table 14.4 and the effective doses in Table 4.5 in Chapter 14. Radiation dose is always higher with long-lived and α -emitting radionuclides. The GSD values for females (1.9 mrad or 19 mGy) is almost twice those of males (1.1 mrad or 10.9 mGy) (NCRP 100, 1989).

Risks from diagnostic procedures include both somatic and genetic effects. Normally, these effects are minimal from diagnostic procedures for humans because doses from these procedures are considered low. Doses from nuclear medicine procedures are even lower than those from diagnostic x-ray procedures. However, based on the LNT model, there is no reason to believe

that there is no risk from diagnostic exposures, no matter how small the doses are. There may not be acute effects, but long-term effects such as carcinogenesis, teratogenic effects from fetal exposure, and genetic effects in the future offspring can occur. The probabilities of fatal cancers, nonfatal cancers, and hereditary effects have been estimated by the ICRP to be 4.0%, 0.8%, and 0.8%, respectively, for adult radiation workers and 5.0%, 1.0%, and 1.3%, respectively, for the whole population (ICRP 0, 1991).

An important quantity in the assessment of risk from radiation exposures is the collective effective dose, which is defined as the sum of the products of the effective dose and the number of persons exposed for each diagnostic procedure (NCRP 100, 1989). The age-weighted value per year for low dose and dose rates is estimated to be 58,000 person-Sv (5.8 million person-rem) for diagnostic radiological procedures and 13,500 person-Sv (1.35 million person-rem) for nuclear medicine procedures in the United States.

Based on a collective effective dose of 58,000 person-Sv (5.8 million person-rem) and the probabilities of cancers given above, Hall (1994) estimated the risks from 1 year of diagnostic radiology practice to be 2320 fatal cancers, 464 nonfatal cancers, and 464 serious heritable defects. Similarly, based on a collective dose of 13,500 person-Sv (1.35 million person-rem), the risk from 1 year of nuclear medicine practice is 540 fatal cancers, 103 nonfatal cancers, and 108 serious heritable defects. These risks are quite low compared to the number of examinations performed annually.

The benefit from diagnostic procedures (both x-ray and nuclear medicine) is the immediate diagnosis of the disease that can lead to the appropriate treatment and its ultimate cure. Argument should prevail in favor of the benefit for the use of radiation for diagnosis over the risks that may appear in later years in the individual himself or the future offspring. However, a judicious use of these procedures is definitely warranted, and a procedure that is not needed should not be done. This argument for the prudent use of radiation also applies to different screening procedures using x-ray, such as mammography,

chest x-rays, and dental x-rays. Many individuals are exposed for screening, but only a small number of people benefit from the early diagnosis, while most of the screened people turn out to be negative. For this reason, the American College of Radiology has recommended annual mammography only for women above 40 years of age, excluding younger women who are much more radiosensitive, some of whom may likely develop breast cancer many years after mammography.

5.4.10. Risk to Pregnant Women

Since radiation can cause a devastating effect on the embryo and fetus in pregnant women, diagnostic radiological and nuclear medicine procedures are contraindicated in pregnant women, despite only a small risk involved with the individual exposed from these procedures. This is particularly important in nuclear medicine procedures, because radiopharmaceuticals reside in the body following a biological half-life and are likely to cross the placenta to cause the fetal damage. β -emitting radionuclides are more damaging than α -emitting radionuclides. Radioiodine administered orally to pregnant women during the gestation period of 15 to 22 weeks can cross the placenta and localize in the fetal thyroid to the extent of 50% to 75%. The fetal thyroid dose at 6 weeks of gestation is of the order of 2.1 Gy/MBq (7.8 rad/mCi) (Watson, 1991).

In most cases, radiologic procedures are avoided in pregnant women by proper screening such as asking them prior to the procedure if they are pregnant or when they had their last menstrual period. However, at times, it is discovered after the procedure that the woman is pregnant. In such situations, steps should be taken to estimate the dose received by the embryo or fetus based on the dosimetry parameters of the radiopharmaceutical. Depending on the period of pregnancy, the question of therapeutic abortion may be considered if the dose is excessive. Some experts believe that a dose of 10 cGy (10 rad) is a reasonable value above which therapeutic abortion should be considered. However, the decision to abort depends on a number of socio-personal factors.

In radionuclide therapy, pregnant women are absolutely excluded because of the anticipated excessive fetal dose. ^{131}I treatment of pregnant women is almost prohibited unless benefit outweighs the risk of the fetus from therapy. Besides the in utero effects, there is a small probability of thyroid cancer induced by the ^{131}I therapy of hyperthyroidism.

5.4.11. Dirty Bombs

A dirty bomb, also called a Radiological Dispersal Device (RDD), is a mix of explosive, such as dynamite, with radioactive materials. After the explosion, in addition to the immediate devastating effects of the explosive material causing injury and property damage, radioactive dust and smoke spread the radioactive contamination into the surrounding areas. Radioactive dust and smoke, if inhaled, can cause ill health effects. The use of dirty bombs by perpetrators is to spread radioactive contamination and create fear and panic, more than anything else. Subsequent decontamination could involve considerable time and cost.

A dirty bomb is not an atomic bomb and is primarily used to disrupt and not destroy the human life. Another type of RDD might involve a very high level of radioactive source hidden in a bus, train, or subway station, where people passing close to the source might get a significant dose of radiation. Prompt detection of these devices (bomb or radioactive source) is essential in order to take protective measures.

The sources of radioactive materials are the hospitals, research facilities, and industrial and construction sites where radioactivity is used for various purposes (diagnosis and treatment at hospitals, research work, sterilizing equipment, and check of welding). Some of the highly radioactive sources are cobalt-60, strontium-90, cesium-137, and iridium-192 used in industrial Dirty Bombs 261 radiographic services. These radionuclides have long half-lives. Many of these sources are mostly in metallic capsule form and the likelihood of dispersion is minimal. However, they can be available in liquid and powder forms and potentially be used in dirty bombs, which can result in wide-spread

contamination in the surrounding areas of explosion. Because one cannot see, taste, or feel radiations, excessive exposure can be received unknowingly by people in the vicinity of the area.

5.5. Types of Radiation Exposure

Radiation exposure from radiation accidents can be localized and/or whole-body type. The localized exposure may be caused by direct handling of or close proximity to highly radioactive sources. The local injury includes erythema, epilation, desquamation, ulceration, or blistering depending on the level of exposure. The treatment of choice for localized injuries is the use of antibiotic for infection and control of pain. In severe cases, amputation or plastic surgery is warranted.

The whole-body exposure causes various acute radiation syndromes that have been discussed earlier in this chapter. These syndromes include hemopoietic, gastrointestinal, and cerebrovascular syndromes depending on the absorbed doses. Although cerebrovascular syndromes occur with 10,000 rem (100 Sv), and result in death, the hemopoietic and gastrointestinal syndromes may be managed by bone marrow transplantation and other prophylactic treatment.

When a RDD explodes, radioactive material may be airborne and contaminate food and water. Internal contamination can occur from the ingestion of contaminated food and water, inhalation of the contaminated air, and diffusion through the skin or wounds. The principle of the treatment of internal contamination primarily involves dilution, displacement by nonradioactive material, complex formation, and blockage. In the case of internal contamination with radioiodine (e.g., incidences of fallout from a nuclear explosion or a nuclear reactor accident), both the NRC and FDA have approved the use of potassium iodide (KI) as a preventive measure. Such use of KI is intended to block the thyroid from trapping ^{131}I and it should be taken before the exposure or within several hours of exposure. The recommended daily dose is 130 mg of KI for adults, 65 mg for 3 to 18 yr old, 32 mg for children

1 month to 3 yr old, and 16 mg for infants less than 1 month old (Mettler and Voelz, 2002).

Outer garments such as clothing and shoes can be contaminated by radioactivity from the explosion of a dirty bomb. Such contamination does not constitute a medical emergency and most of it can be removed by taking off these garments. Minor skin contamination can be eliminated by thorough washing with water and detergent, and a shower, if appropriate. Skin should not be abraded by a heavy brush, as this may facilitate internal absorption. If an individual has a life-threatening condition in addition to the external contamination, the patient must be first managed for the condition before decontamination is carried out. Burns and wounds that are not contaminated should be first covered and then decontamination of the other affected areas carried out.

5.6. Sources of Radiation Exposure

The population at large receives radiation exposure from various sources such as natural radioactivity, medical procedures, consumer products, and occupational sources. The estimates of annual effective dose equivalents from different radiation sources to the U.S. population are tabulated in Table 16.1. The major contribution of the exposure comes from natural sources, particularly from radon from building materials, amounting to 200 mrem (2 mSv)/year accounting for 82% of the total exposure. Excluding radon exposure, the average exposure from natural background consisting of cosmic radiations, terrestrial radiations, and so on amounts to about 100 mrem (1 mSv)/year. This exposure varies with the altitude of places above sea level. For example, the annual cosmic ray exposure in cities such as Denver is about 50 mrem (0.5 mSv) compared to 26 mrem (0.26 mSv) at sea level. Air travel at a height of 39,000 ft (12 km) gives 0.5 mrem/hr (5 mSv/hr), resulting in an annual dose of 1 mrem (10 mSv) to the population.

Terrestrial radiation exposure arises from radionuclides such as ^{40}K and from

decay products of thorium and uranium in soil. It varies from about 16 mrem (160 mSv)/year in the Atlantic ocean to 63 mrem (630 mSv)/year in the Rockies with an average of 28 mrem (280 mSv)/year.

Radionuclides ingested through food, water, or inhalation include ^{40}K and decay products of thorium and uranium, particularly ^{210}Po , and contribute about 39 mrem (390 mSv) annually.

Man-made exposure constitutes about 18% of the total exposure. Medical procedures contribute the highest exposure of all man-made radiation sources. The most exposure comes from diagnostic radiographic procedures with about 39 mrem (390 mSv) annually compared to 14 mrem (140 mSv) for nuclear medicine procedures. Exposure from radiation therapy is relatively small.

Consumer products such as tobacco, water supply, building materials, agricultural products, and television receivers contribute to radiation expo-

Table 6.1. Annual effective dose equivalent in the U.S. population from different sources circa 1980 to 1982

Sources	Average annual effective dose equivalent in mrem (mSv)
Natural sources	
Radon	200 (2.0)
Cosmic rays	27 (0.27)
Terrestrial	28 (0.28)
Ingested radionuclides	39 (0.39)
Medical procedures	
Diagnostic x-rays	39 (0.39)
Nuclear medicine	14 (0.14)
Radiation therapy	<1 (0.01)
Consumer products	5–13 (0.05–0.13)
Occupational	0.9 (0.009)
Nuclear fuel cycle	0.05 (0.0005)
Miscellaneous	0.06 (0.0006)
Total	~360 (3.6)

Adapted with permission from NCRP Report No. 93. *Ionizing Radiation Exposure of the Population of the United States*. Bethesda, MD: NCRP; 1987:

Tables 6.1 and 2.4. sure through consumption. Exposure from smoking has been

estimated to be 1.3 mrem (13 mSv)/year, which is not included in Table 7.1, because it is difficult to calculate the collective effective dose equivalent for the entire population. The total exposure from consumer products varies between 5 and 13 mrem (50 and 130 mSv)/year.

Occupational exposure is received by the workers in reactor plants, coal mines, and other industries using radionuclides. This value is about 0.9 mrem (9 mSv)/year, which is quite small, because a great deal of precaution is taken to reduce exposure in the workplace.

Nuclear power plants around the country release small amounts of radionuclides to the environment, which cause radiation exposure to the population. This value is of the order of 0.05 mrem (0.5 mSv)/year.

5.7. Caution Signs and Labels

The NRC requires that specific signs, symbols, and labels be used to warn people of possible danger from the presence of radiation. These signs use magenta, purple, or black color on yellow background; some typical signs are shown in Figure 16.1.

Caution: Radiation Area. This sign must be posted in radiation areas.

Caution: High Radiation Area or *Danger: High-Radiation Area.* This sign must be posted in high-radiation areas.

Caution: Radioactive Material or *Danger: Radioactive material.* This sign is posted in areas or rooms in which 10 times the quantity of any licensed material specified in Appendix C of 10CFR20 are used or stored. All containers with quantities of licensed materials exceeding those specified in Appendix C of 10CFR20 should be labeled with this sign. These labels must be removed or defaced before disposal of the container in the unrestricted areas.

Caution signs are not required in rooms storing the sealed sources, provided the radiation exposure at 1 foot (30 cm) from the surface of the source reads less than 5 mrem (50 mSv)/hr. Caution signs are not needed in rooms

R



Fig.6.1. Various radiation caution signs and labels.

where radioactive materials are handled for less than 8 hr, during which time the materials are constantly attended.

5.8. ALARA Program

The established dose limits are the upper limits for radiation exposure to individuals. The NRC has instituted the ALARA (as low as reasonably achievable) concept to reduce radiation exposure to individuals to a minimum. The ALARA concept calls for a reasonable effort to maintain individual and collective radiation exposure as low as possible. Under this concept, techniques, equipment, and procedures are all critically evaluated. According to NRC Regulatory Guide, under the ALARA concept, when the exposure to a radiation worker exceeds 10% of the occupational exposure limit in a quarter (Action Level I), an investigation is made by the RSO, and the report is reviewed by the RSC. When the exposure exceeds 30% of the occupational exposure limit (Action Level II), corrective actions are taken or the licensee must justify a higher dose level for ALARA in that particular situation, but not to exceed annual occupational dose limit.

5.9. Principles of Radiation Protection

Of the various types of radiation, the α -particle is most damaging because of its charge and great mass, followed in order by the β -particle and the γ -ray. Heavier particles have shorter ranges and therefore deposit more energy per unit path length in the absorber, causing more damage. On the other hand, γ -rays and x-rays have no charge or mass and therefore have a longer range in matter and cause relatively less damage in tissue. Knowledge of the type and energy of radiations is essential in understanding the principles of radiation protection.

The cardinal principles of radiation protection from external sources are based on four factors: time, distance, shielding, and activity.

5.9.1. Time

The total radiation exposure to an individual is directly proportional to the time of exposure to the radiation source. The longer the exposure, the higher the radiation dose. Therefore, it is wise to spend no more time than necessary near radiation sources.

Adapted from Goodwin PN: Radiation safety for patients and personnel. In: Freeman LM, ed.

Freeman and Johnson's Clinical Radionuclide Imaging. 3rd ed. Philadelphia: WB Saunders Co; 1984: 320.

5.9.2. Distance

The intensity of a radiation source, and hence *the radiation exposure, varies inversely as the square of the distance from the source to the point of exposure*. It is recommended that an individual should keep as far away as practically possible from the radiation source. Procedures and radiation areas should be designed so that individuals conducting the procedures or staying in or near the

radiation areas receive only minimum exposure.

The radiation exposure from γ -ray and x-ray emitting radionuclides can be estimated from the *exposure rate constant*, G , which is defined as the exposure from g-rays and x-rays in R/hr from 1 mCi (37 MBq) of a radionuclide at a distance of 1 cm. Each g- and x-ray emitter has a specific value of G , which has the unit of $R \cdot \text{cm}^2/\text{mCi} \cdot \text{hr}$ at 1 cm or, in System Internationale (SI) units, $\text{mGy} \cdot \text{m}^2/\text{GBq} \cdot \text{hr}$ at 1 m. The G values are derived from the number of γ -ray and x-ray emissions from the radionuclide, their energies, and their mass absorption coefficients in air. Because γ -rays or x-rays below some 10 or 20 keV are absorbed by the container and thus do not contribute significantly to radiation exposure, often g-rays and x-rays above these energies only are included in the calculation of G .

5.9.3. Shielding

Various high atomic number (Z) materials that absorb radiations can be used to provide radiation protection. Because the ranges of α - and β - particles are short in matter, the containers themselves act as shields for these radiations. γ -Radiations, however, are highly penetrating. Therefore, highly absorbing material should be used for shielding of γ -emitting sources, although for economic reasons, lead is most commonly used for this purpose. The half-value layer (HVL) of absorbent material for different radiations is an important parameter in radiation protection and is related to linear attenuation coefficient of the photons in the absorbing material.

Obviously, shielding is an important means of protection from radiation. Radionuclides should be stored in a shielded area. The radiopharmaceutical dosages for patients should be carried in shielded syringes. Radionuclides emitting β -particles should be stored in containers of low- Z material such as aluminum and plastic because in high- Z material, such as lead, they produce highly penetrating bremsstrahlung radiations. For example, ^{32}P is a β^-

emitter and should be stored in plastic containers instead of lead containers.

5.10. Activity

It should be obvious that the radiation exposure increases with the intensity of the radioactive source. The greater the source strength, the more the radiation exposure. Therefore, one should not work unnecessarily with large quantities of radioactivity.

6. References

- 1- ICRP Publication 60: *1990 Recommendations of the International Commission on Radiological Protection*. New York: Pergamon Press; 1991.
- 2- *Physics and Radiobiology of Nuclear Medicine*, Gopal B. Saha, Third Edition, 2006
- 3- *Concepts Of Nuclear Physics* , Bernard L.Cohen (1984).
- 4- *Nuclear Physics* ,Addison Wesley , Kaplan , I.(1979).
- 5- *Nuclei and Particles* , Segre , E.Benjam In (1965).
- 6- الفيزياء النووية ، د. احمد الناغى ، دار الفكر العربى (2005) .

Contents

1. Structure of Matter.....	2
1.1. Matter and Energy.....	2
1.1.1. Radiation.....	3
1.1.2. The Atom.....	4
1.1.3. Electronic Structure of the Atom.....	5
1.1.6. Nuclear Binding Energy.....	13
1.1.7. Nuclear Nomenclature.....	14
1.1.8. Chart of the Nuclides.....	15
2. Radioactive Decay.....	16
2.1. Spontaneous Fission.....	16
2.2. Internal Conversion.....	17
2.2.1. Isomeric Transition.....	19
2.2.2. Gamma (γ)-Ray Emission.....	19
2.3. Alpha (α)-Decay.....	20
2.4. Beta (β^-) - Decay.....	20
2.5. Positron (β^+) - Decay.....	23
2.6. Electron Capture.....	25
3. Kinetics of Radioactive Decay.....	27
3.1. Radioactive Decay Equations.....	27
3.1.1. General Equation.....	27
3.1.2. General Equation.....	28
3.1.2.1. Half-Life.....	28
3.1.2.2. Mean Life.....	31
3.1.2.3. Effective Half-Life.....	31
3.1.3. Units of Radioactivity.....	32
3.2. Successive Decay Equations.....	33
3.2.1. General Equation.....	33

3.2.2.	Transient Equilibrium	34
3.2.3.	Secular Equilibrium	36
4.	Internal Radiation Dosimetry.....	37
4.1.	Radiation Units	37
4.2.	Dose Calculation	40
4.3.	Radiation Dose Rate	40
4.4.	Cumulative Radiation Dose	42
4.5.	Radiation Dose in SI Units.....	46
4.6.	Effective Dose Equivalent and Effective Dose	47
4.7.	Pediatric Dosages.....	49
5.	Radiation Biology	50
5.1.	The Cell.....	50
5.2.	Effects of Radiation.....	54
5.2.1.	DNA Molecule	54
5.2.2.	Chromosome.....	55
5.2.3.	Direct and Indirect Actions of Radiation.....	59
5.2.4.	Radiosensitivity of Cells.....	60
5.2.5.	Cell Survival Curves	62
5.2.6.	Factors Affecting Radiosensitivity	65
5.2.7.	Dose Rate	65
5.2.8.	Linear Energy Transfer	66
5.2.9.	Chemicals	66
5.2.10.	Radiosensitizers	66
5.2.11.	Radioprotectors.....	69
5.3.	Stage of Cell Cycle.....	69
5.3.1.	Classification of Radiation Damage	70
5.4.	Stochastic and Deterministic Effects.....	71
5.4.1.	Acute Effects of Total Body Irradiation.....	72
5.4.2.	Hemopoietic Syndrome	73

5.4.3.	Gastrointestinal Syndrome.....	73
5.4.4.	Cerebrovascular Syndrome.....	74
5.4.5.	Long-Term Effects of Radiation.....	74
5.4.6.	Somatic Effects.....	75
5.4.6.1.	Carcinogenesis.....	75
5.4.6.2.	Epidemiologic Evidence of Carcinogenesis.....	76
5.4.7.	Dose–Response Relationship.....	77
5.4.7.1.	Risk Estimates of Excess Cancer.....	79
5.4.7.1.1.	Leukemia.....	79
5.4.7.1.2.	Breast Cancer.....	80
5.4.7.1.3.	Other Cancers.....	80
5.4.7.2.	Radiation Damage to Skin.....	81
5.4.7.3.	Radiation Damage to Reproductive Organs.....	81
5.4.7.4.	Nonspecific Life-Shortening.....	82
5.4.7.4.1.	Cataractogenesis.....	82
5.4.7.5.	Radiation Damage to Embryo and Fetus.....	83
5.4.8.	Genetic Effects.....	84
5.4.8.1.	Spontaneous Mutations.....	84
5.4.8.2.	Doubling Dose.....	85
5.4.8.3.	Genetically Significant Dose.....	85
5.4.9.	Risk Versus Benefit in Diagnostic Radiology and Nuclear Medicine.....	87
5.4.10.	Risk to Pregnant Women.....	89
5.4.11.	Dirty Bombs.....	90
5.5.	Types of Radiation Exposure.....	91
5.6.	Sources of Radiation Exposure.....	92
5.7.	Caution Signs and Labels.....	94
5.8.	ALARA Program.....	95
5.9.	Principles of Radiation Protection.....	96
5.9.1.	Time.....	96

5.9.2. Distance.....	96
5.9.3. Shielding.....	97
5.10. Activity.....	98
6. Refrences.....	98
جامعة جنوب الوادي.....	103
كلية العلوم.....	103
قسم: الفيزياء.....	103
توصيف مقرر دراسي.....	103

جامعة جنوب الوادي

كلية العلوم

قسم: الفيزياء

توصيف مقرر دراسي

1- بيانات المقرر	
الرمز الكودي : 319 ف	اسم المقرر: فيزياء اشعاعية ووحوية
التخصص بيولوجي	عدد الوحدات الدراسية نظري (2) عملي (4)
2- هدف المقرر:	تعميق مفهوم الطالب عن المواد المشعة وانواع الاشعاعات وطرق قياسها والكشف عنها وتأثيراتها على الكائنات الحية
3- المستهدف من تدريس المقرر (نواتج التعلم)	
أ المعلومات والمفاهيم:	<p>ان يتعرف الطالب على:</p> <p>1 – نظرية الاضمحلال الاشعاعي.</p> <p>2 – التحول الاشعاعي.</p> <p>3 – المواد المشعة طبيعيا والمواد المشعة صناعيا.</p> <p>4 – الاتزان الاشعاعي.</p> <p>5- خصائص جسيمات الفا وبيتا وجاما تأثيراتها على الكائنات الحية.</p> <p>6- التأثيرات الكيميائية والبيولوجية للاشعاع على الجسم.</p> <p>7- التعرض للاشعاع واعراضه والوقاية منه</p>
ب – المهارات الذهنية:	<p>ب1- ان يفسر الطالب: نظرية الاضمحلال الاشعاعي.</p> <p>ب2- ان يفرق الطالب بين: المواد المشعة طبيعيا والمواد المشعة صناعيا.</p> <p>ب3- ان يستنتج الطالب: التحول الاشعاعي.</p> <p>ب4- ان يفسر الطالب: الاتزان الاشعاعي.</p> <p>ب5- ان يفرق الطالب: بين خصائص جسيمات الفا وبيتا وجاما وتأثيراتها على الكائنات الحية.</p> <p>ب6- ان يستنتج الطالب: طرق الكشف عن المواد المشعة.</p> <p>ب7- ان يفسر الطالب: اعراض التعرض للاشعاع.</p>
ج_ المهارات المهنية الخاصة بالمقرر:	<p>ج1- ان يستخدم الطالب بعض اجهزة الكشف عن الاشعاعات النووية.</p> <p>ج2- ان يتعامل الطالب مع المواد المشعة بامان</p>

د - المهارات العامة:	د1- أن يكون الطالب قادر التواصل الجيد من خلال المناقشات
4- محتوى المقرر:	اساس نظرية الاضمحلال الاشعاعي - التحول المتتابع للمواد المشعة طبيعيا - الاتزان الاشعاعي - خصائص قياس النشاط الاشعاعي وعلاقته بالجرعة الممتصة - خصائص جسيمات الفا وبيتا وجاما وتأثيراتها على الكائنات الحية . المصادر الطبيعية للاشعة - التأثير الكيميائي والبيولوجي للاشعة على الجسم - التعرض للاشعاع واعراضة والوقاية منه - المصادر الاخرى للاشعاع الضار.

5- اساليب التعليم والتعلم	المحاضرات المناقشات التكليفات
6- اساليب التعليم والتعلم للطلاب ذوي القدرات المحدودة	التعلم التعاوني
7- تقويم الطلاب :	
أ- الاساليب المستخدمة	امتحان نهاية العام
ب - التوقيت	امتحان نظري : الاسبوع السادس عشر امتحان عملي : الاسبوع الخامس عشر امتحان اعمال سنة : خلال المحاضرات
ج - توزيع الدرجات	أعمال سنه : 10% شفوى : 10 % أمتحان عملي 20% أمتحان نظري : 60%
8- قائمة الكتب الدراسية والمراجع	
أ- مذكرات	مذكرة
ب - كتب ملزمة	
ج- كتب مقترحة	1-Physics and Radiobiology of Nuclear Medicine Third Edition, saha, 2006 2- Concepts Of Nuclear Physics , Bernard L.Cohen (1984). 3- Nuclear Physics ,Addison Wesley , Kaplan , I.(1979). 4- Nuclei and Particles , Segre , E.Benjam In (1965). 5- الفيزياء النووية ، د. احمد الناعى ، دار الفكر العربى (2005).
د - دوريات علمية أو نشرات ...	