



**Lectures in**

**Special and General Relativity**

**For**

**Third Year Students**

**Faculties of Science and Education**

**Prepared By**

**Dr. Badry N. Abdalla**

**2023-2024**

<b>Content</b>	<b>Pages</b>
<b>Course objectives</b>	<b>5</b>
<b>Chapter (1) : Pre-Relativistic Physics</b>	<b>6</b>
Galilean-Newton Relativity	7-9
Galilean-Transformation	11-12
The Michelson–Morley Experiment	12-17
<b>Chapter (2) : Pre-Relativity ( I )</b>	<b>18</b>
Difference between the special and general theories of Relativity	19
Postulates of Special Relativity	20-24
Transformation between systems	25
Lorentz Transformation	25-28
4-Vectors	28
Time Dilation	29-34
Space contraction	34
Length Contraction	34-35
Simultaneity	35-36
Twin-Paradox	36-38
Spacetime	38-40
Relativistic Doppler Shift	41-42
Solved Problems	43-54
<b>Chapter (3) : Relativistic Kinematics (Relativity II )</b>	<b>55</b>

Relativistic mass	56-57
Energy and momentum	58-63
Solved problems	64-75
<b>Chapter (4) : General Relativity</b>	78
Neoton's Law of Gravity	78
Curvature of Space	78-79
Light and gravity	80-81
Tensors	81-82
Curved Space	83-84
Gravitational Wave	84

### **Important topics in special relativity**

- The failure of the Galilean transformations.
- Lorentz transformations.
- Time and Space in special relativity.
- Relativistic momentum and Energy.

### **Course Learning Objectives**

#### **After completion of this course, student will be able to**

##### 1. Einstein's Postulates

- State and explain both of Einstein's postulates.
- Explain what an inertial frame of reference is.
- Describe one way the speed of light can be changed.

##### 2. Simultaneity And Time Dilation

- Describe simultaneity.
- Describe time dilation.
- Calculate  $\gamma$ .
- Compare proper time and the observer's measured time.
- Explain why the twin paradox is a false paradox.

##### 3. Length Contraction

- Describe proper length.
- Calculate length contraction.
- Explain why we don't notice these effects at everyday scales.
- Compare proper length and the observer's measured length..

##### 4. Relativistic Addition of Velocities

- Calculate relativistic velocity addition.
- Explain when relativistic velocity addition should be used instead of classical addition of velocities.
- Calculate relativistic Doppler shift.

##### 5. Relativistic Momentum

- Calculate relativistic momentum.
- Explain why the only mass it makes sense to talk about is rest mass.

##### 6. Relativistic Energy

- Compute total energy of a relativistic object.
- Compute the kinetic energy of a relativistic object.
- Describe rest energy, and explain how it can be converted to other forms.
- Explain why massive particles cannot reach  $C$ .

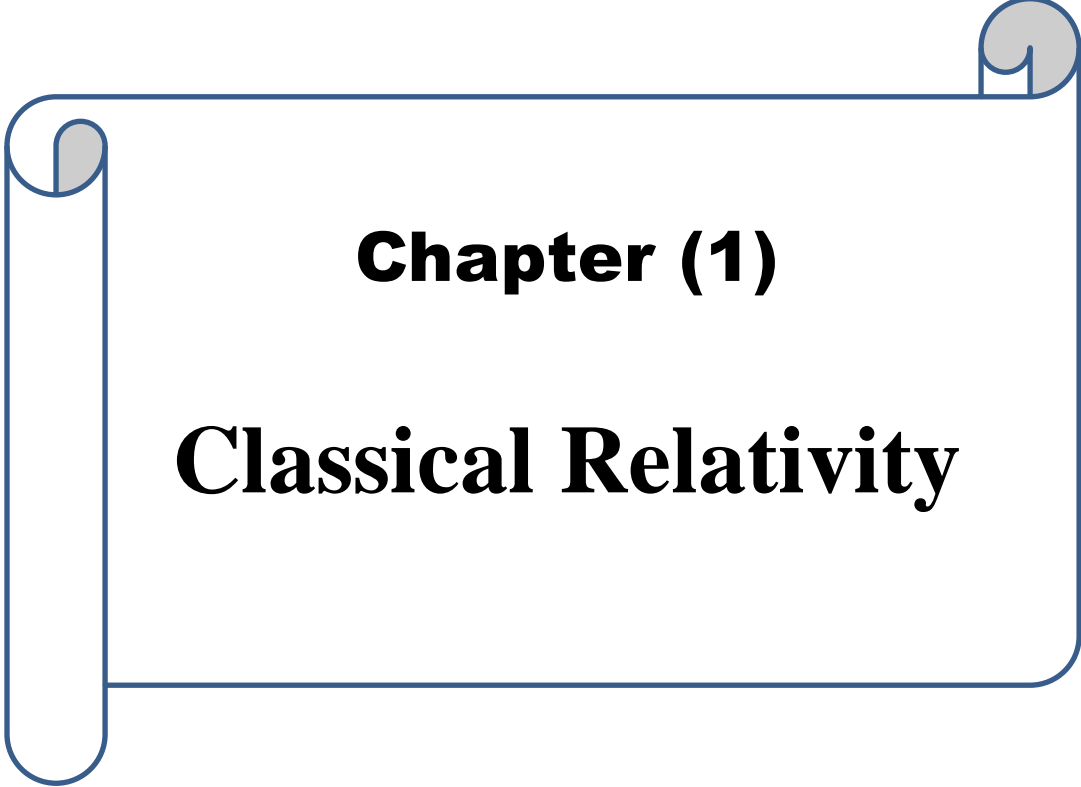

# **Chapter (1)**

# **Classical Relativity**

## Chapter (1)

### Classical Relativity Physics

#### 1-1 : Galilean-Newton Relativity

In order to study General Relativity one starts discussing Special Relativity. To this end, it is important to briefly look at pre-relativistic Physics to see how Special Relativity arose.

**The starting point of Special Relativity is the study of motion. For this one needs the following ingredients :**

- Frames of reference. These consist of an origin in space, 3 orthogonal axes and a clock.

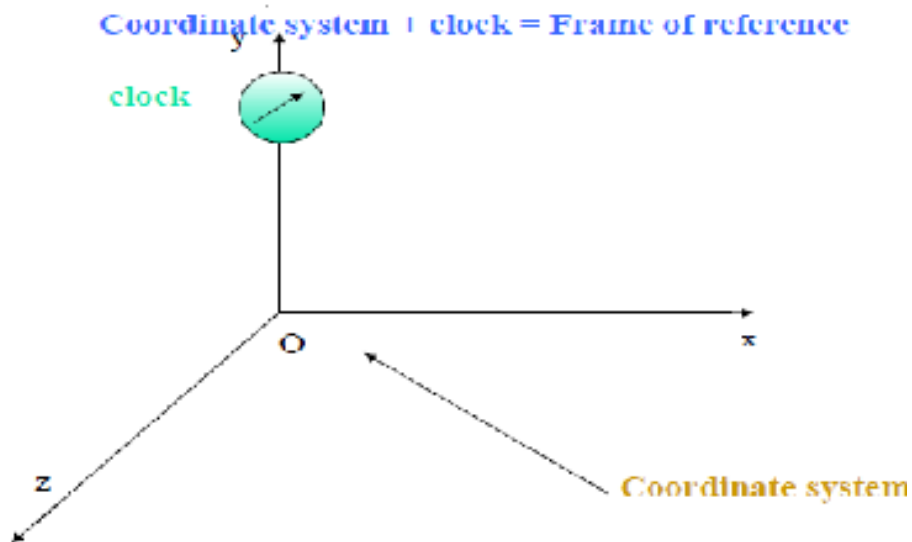

- Events. : This notion denotes a single point in space together with a single point in time. Thus, events are characterized by 4 real numbers: an ordered triple  $(x; y; z)$  giving the location in space relative to a fixed coordinate system and a real number giving the Newtonian time. One denotes the event by  $E = (t; x; y; z)$ .

There are an infinite number of frames of reference. Motion relative to each frame looks, in principle, different. Hence, it is natural to ask: is there a subset of these frames which are in some sense simple, preferred or natural? The answer to this question is yes.

These are the so-called inertial frames. In an inertial frame an isolated, non-rotating, un-accelerated body moves on a straight line and uniformly.

Inertial frames are not unique. There are actually an infinite number of these. This raises the question: can one tell in which inertial frame are we in? It turns out that within the framework of Newtonian Mechanics this is not possible. More precisely, one has the following :

**Galilean Principle of Relativity** : Laws of mechanics cannot distinguish between inertial frames. This implies that there is no absolute rest. In other words, the laws of Mechanics retain the same form in different inertial frames. In this sense, Relativity predates Einstein.

### **1.2 : Laws of Newton**

The three Laws of Newtonian Mechanics<sup>4</sup> are :

- (1) Any material body continues in its state of rest or uniform motion (in a straight line) unless it is made to change the state by forces acting on it. This principle is equivalent to the statement of existence of inertial frames.
- (2) The rate of change of momentum is equal to the force.
- (3) Action and reaction are equal and opposite.

These laws or principles, together with the following fundamental assumptions (some of which are implicitly assumed in Newton's laws) amount to the Newtonian framework:

- 1- Absolute time, motion and space as defined in Newton's "Philosophiae Principia Mathematica"
- 2- **Space and time are continuous** |i.e. not discrete. This is necessary to make use of the Calculus. There is no limit to the accuracy with which quantities such as time and space can be measured.

3- **There is a universal (absolute) time.** Different observers in different frames measure the same time. In fact, Newton also regarded space to be absolute as well.

However, the absoluteness of space is not necessary for the development of the Newtonian framework, as space intervals turn out to be invariant under Galilean transformations. Historically, Newton demanded this for subjective reasons.

- 4- Mass remains invariant (**absolute**) as viewed from different inertial frames.
- 5- The Geometry of space is Euclidean. For example, the sum of angles in any triangle equals 180 degrees.
- 6- lengths or distances are absolute no matter what is the velocity.
- 7- Infinitely many inertial frames of reference, each one in relative motion to absolute space.
- 8- Universal time throughout space where all inertial frames share this universal time.
- 9- All laws of physics are the same in all inertial frames of reference whether at rest or in motion relative to absolute space.
- 10-Speed of light is instantaneous (information transmission is instantaneous).
- 11- All possibilities of unbounded, relative motion.
- 12-Newton's Law of Universal Gravitation holds as derived from Newton's "Axioms, or Laws of Motion".
- 13-Inertial frames of reference are related by Galilean rules of transformation - i.e., simple vector addition and subtraction .
- 14- Action at a distance - corpuscular theory of the ( luminiferous ) aether.
- 15-Euclidean geometry of space - Cartesian or polar coordinates systems.
- 16-Conservation Laws of energy, mass and momentum.
- 17-Gravity attraction is directly related to mass and inversely to absolute distance.



18-Bodies or objects are constituted of matter whose measure is the amount of ( inertial ) mass.

19-Energy and mass are distinct entities as is force

### 4- Galileo's relativity

Newton's laws of motion must be implemented relative to some reference frame.

A reference frame is called an **inertial frame** if Newton's laws are valid in that frame.

Such a frame is established when a body, not subjected to net external forces, moves in rectilinear motion **at constant velocity**.

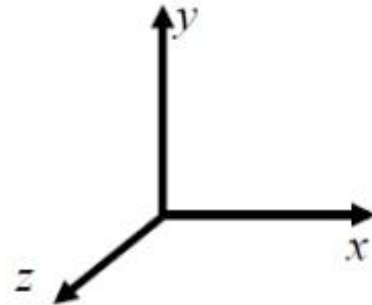

If Newton's laws are valid in one reference frame, then they are also valid in another reference frame moving at a uniform velocity relative to the first system.

This is referred to as the **Galilean invariance**.

**Galilean transformation:** for a point P

In one frame K:  $P = (x, y, z, t)$

In another frame K:  $P = (x', y', z', t')$

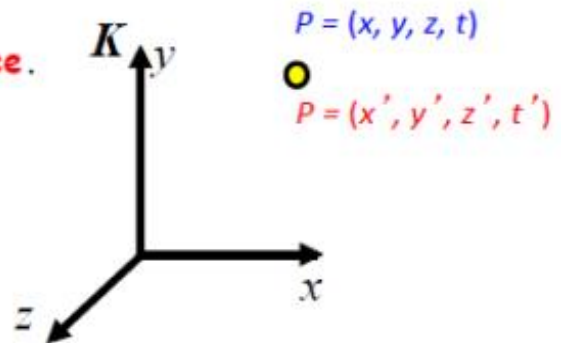

### FRAME OF REFERENCE

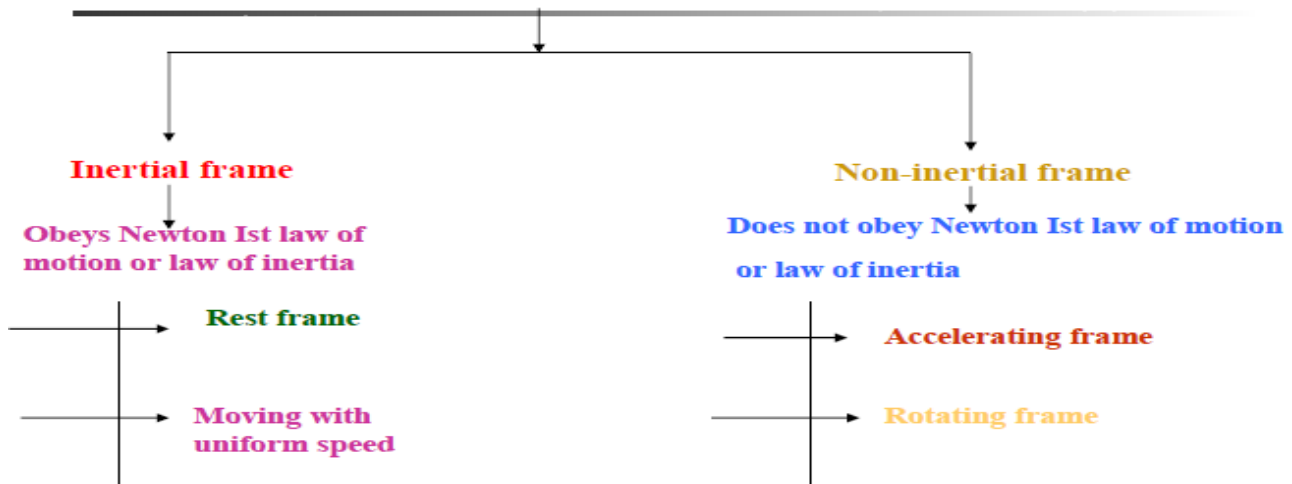

## Galilean Transformation :

Conditions of the Galilean Transformation

- Parallel axes
- O' has a constant relative velocity in the  $x$ -direction with respect to O
- **Time** ( $t$ ) for all observers is a *Fundamental invariant*, i.e., the same for all inertial observers
- Time is universal, so therefore  $t = t'$ .

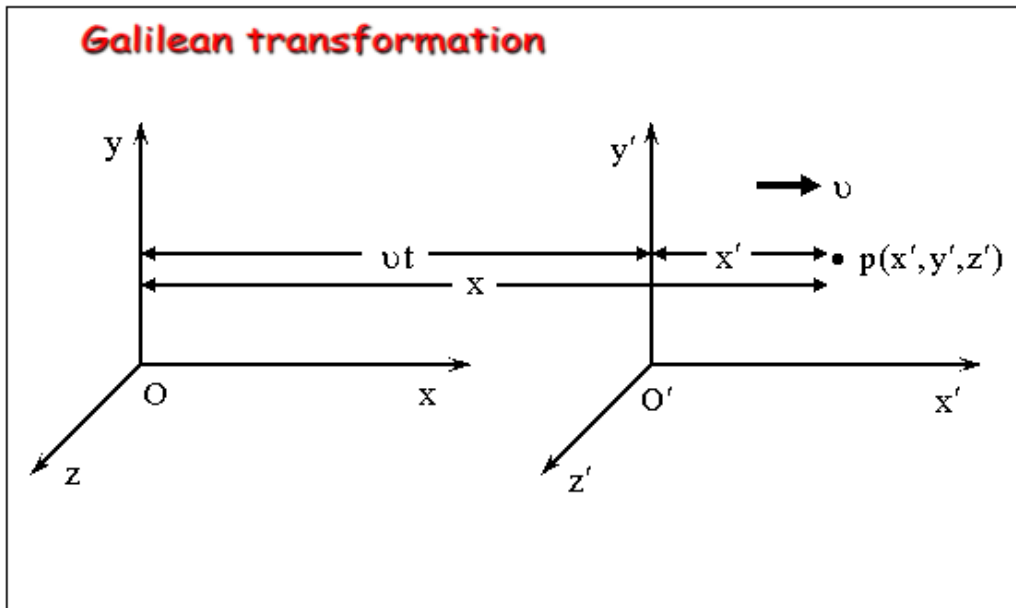

Galilean transformation

$$x = x' + v_x \Delta t'$$

$$y = y'$$

$$z = z'$$

$$\Delta t = \Delta t'$$

Inverse Galilean transformation

$$x' = x - v_x \Delta t'$$

$$y' = y$$

$$z' = z$$

$$\Delta t' = \Delta t$$

The corresponding velocity transformations are

$$u_x = \frac{dx}{dt} = \frac{dx'}{dt} + v_x = u_x' + v_x$$

$$u_y = \frac{dy}{dt} = \frac{dy'}{dt} = u_y'$$

$$u_z = \frac{dz}{dt} = \frac{dz'}{dt} = u_z'$$

$$\text{Inverse } \Rightarrow \begin{aligned} u_x' &= \frac{dx'}{dt} = \frac{dx}{dt} - v_x = u_x - v_x \\ u_y' &= \frac{dy'}{dt} = \frac{dy}{dt} = u_y \\ u_z' &= \frac{dz'}{dt} = \frac{dz}{dt} = u_z \end{aligned}$$

## For acceleration

$$\begin{array}{l}
 a_x = \frac{du_x}{dt} = a'_x \\
 a_y = \frac{du_y}{dt} = a'_y \\
 a_z = \frac{du_z}{dt} = a'_z
 \end{array}
 \quad \text{Inverse} \Rightarrow \quad
 \begin{array}{l}
 a'_x = \frac{du'_x}{dt} = a_x \\
 a'_y = \frac{du'_y}{dt} = a_y \\
 a'_z = \frac{du'_z}{dt} = a_z
 \end{array}$$

Accelerations are the same in both K and K' frames!

Note that for two inertial frames, the  $a_x = a'_x$ ,  $a_y = a'_y$ , and  $a_z = a'_z$ .

### Success Or Advantages of Galilean Transformation :

Galileo Transformation has proved several of physics' laws such as conservation of mass , energy, momentum, and second newton's law.

### Frailer of Galilean Transformation :

Maxwell's equations, which summaries electricity and magnetism, cause the Galilean Transformation to fail on following :

1. Galilean Transformation failed to explain the actual result of Michelson-Morley experiment.
2. They are not invariant under the Galilean Transformation.
3. Galilean Transformation failed to prove unchanged of electromagnetism's laws , specially the rectilinear theory of light.
4. They predict the speed of light is independent of the inertial reference frames

instead of ( $c' = c + v$ ) as required by Galilean Relativity.

### Example : The nature of rectilinear propagation of light

Assume there is a signal of light moves by a velocity (C) in Either medium , if there is an observer exist in this medium and measures the light speed as (C). If there is

another observer exist in another inertial frame reference and moves with relative velocity ( $v$ ) with respect to the first inertial reference frame. This observer will measure light velocity given by  $C - v$ , if he moves in the same direction of light propagation and he will measures it by  $C + v$ , if he was moves in opposite direction of the propagation of light as shown in the following Fig.

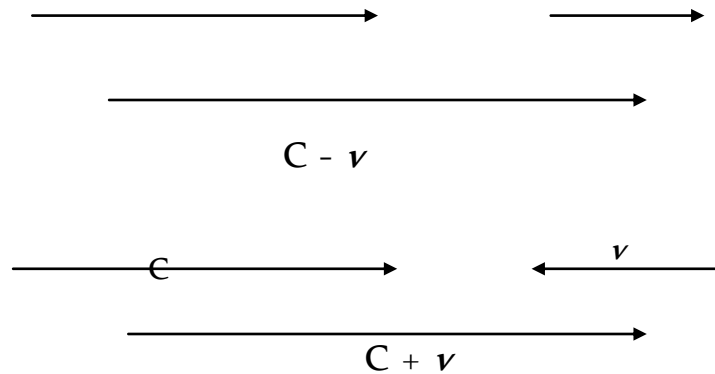

This means that, the speed of light not constant, it differ from reference frame to another, and it only has constant value at inertial reference frame, it is the Ether medium.

### **The Transition to Modern Relativity**

- Although Newton's laws of motion had the same form under the Galilean transformation, Maxwell's equations did not.
- In 1905, Albert Einstein proposed a fundamental connection between space and time and that Newton's laws are only an approximation.

#### **1: The Need for Ether**

● The wave nature of light suggested that there existed a propagation medium called the *luminiferous ether* or just ether.

- Ether had to have such a low density that the planets could move through it without loss of energy

- It also had to have an elasticity to support the high velocity of light waves

### Maxwell's Equations

- In Maxwell's theory the speed of light, in terms of the permeability and permittivity of free space, was given by

$$v = c = 1 / \sqrt{\mu_0 \epsilon_0}$$

- Thus the velocity of light between moving systems must be a constant

### An Absolute Reference System

- Ether was proposed as an absolute reference system in which the speed of light was this constant and from which other measurements could be made.
- The Michelson–Morley experiment was an attempt to show the existence of ether.

### 2.2: The Michelson-Morley Experiment

- Albert Michelson (1852–1931) was the first U.S. citizen to receive the Nobel Prize for Physics (1907), and built an extremely precise device called an *interferometer* to measure the minute phase difference between two light waves traveling in mutually orthogonal directions.

### The Michelson Interferometer

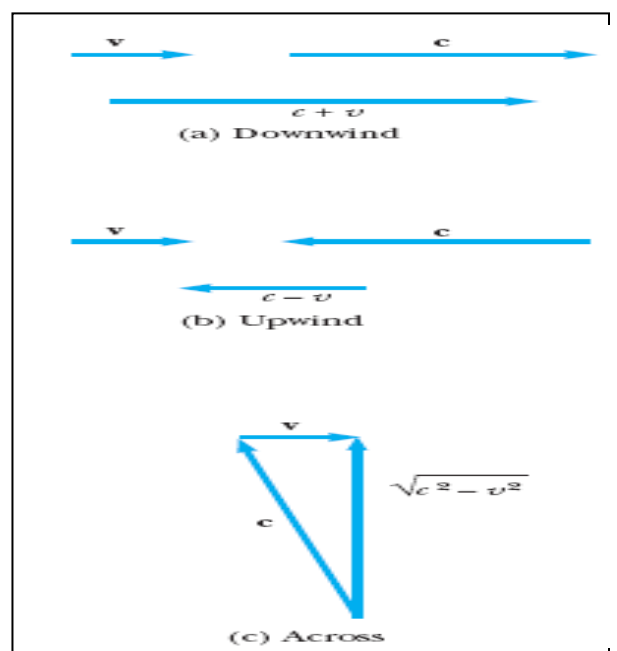
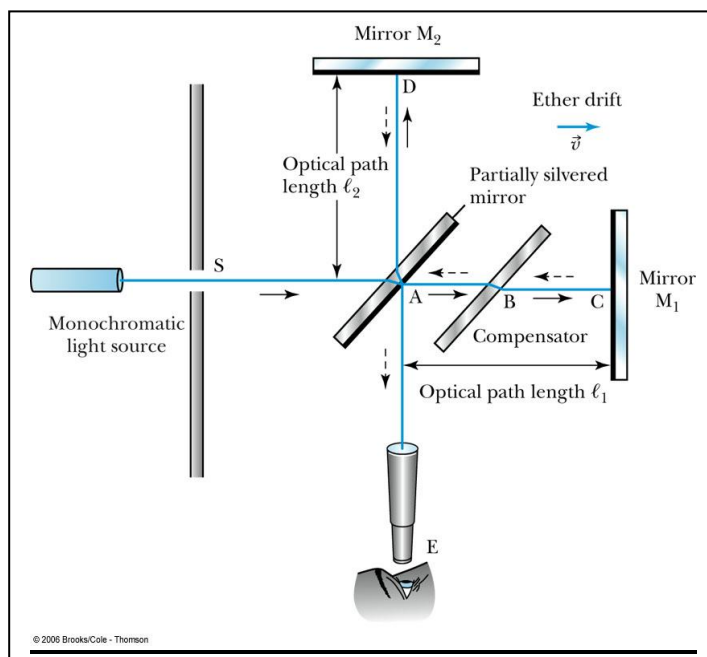

- 1-AC is parallel to the motion of the Earth inducing an “ether wind”
2. Light from source S is split by mirror A and travels to mirrors C and D in mutually perpendicular directions
3. After reflection the beams recombine at A slightly out of phase due to the “ether wind” as viewed by telescope E.

**Typical interferometer fringe pattern expected when the system is rotated by 90°**

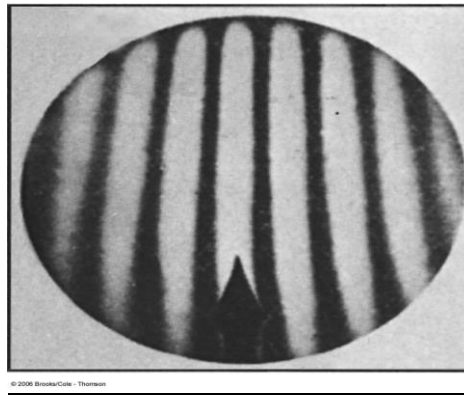

**The Analysis**

**Assuming the Galilean Transformation**

Time  $t_1$  from A to C and back:

$$t_1 = \frac{\ell_1}{c+v} + \frac{\ell_1}{c-v} = \frac{2c\ell_1}{c^2 - v^2} = \frac{2\ell_1}{c} \left( \frac{1}{1 - v^2/c^2} \right)$$

Time  $t_2$  from A to D and back:

$$t_2 = \frac{2\ell_2}{\sqrt{c^2 - v^2}} = \frac{2\ell_2}{c} = \frac{1}{\sqrt{1 - v^2/c^2}}$$

So that the change in time is:

$$\Delta t = t_2 - t_1 = \frac{2}{c} \left( \frac{\ell_2}{\sqrt{1 - v^2/c^2}} - \frac{\ell_1}{\sqrt{1 - v^2/c^2}} \right)$$

Upon rotating the apparatus, the optical path lengths  $\ell_1$  and  $\ell_2$  are interchanged producing a different change in time: (note the change in denominators)

$$\Delta t' = t'_2 - t'_1 = \frac{2}{c} \left( \frac{\ell_2}{1 - v^2/c^2} - \frac{\ell_1}{\sqrt{1 - v^2/c^2}} \right)$$

Thus a time difference between rotations is given by:

$$\Delta t' - \Delta t = \frac{2}{c} \left( \frac{\ell_1 + \ell_2}{1 - v^2/c^2} - \frac{\ell_1 + \ell_2}{1 - v^2/c^2} \right)$$

and upon a binomial expansion, assuming  $v/c \ll 1$ , this reduces to

$$\Delta t' - \Delta t \approx v^2(\ell_1 + \ell_2)/c^3$$

Because  $v^2/c^2 \ll 1$ , this expression can be simplified by using the following binomial expansion after dropping all terms higher than second order:

$$(1 - x)^n \approx 1 - nx \quad (\text{for } x \ll 1)$$

In our case,  $x = \frac{v^2}{c^2}$ , and we find

$$\Delta t = t_1 - t_2 \approx \frac{Lv^2}{c^3}$$

The time difference between the two light beams gives rise to a phase difference between the beams, producing the interference fringe pattern when they combine at the position of the telescope. A difference in the pattern (Fig. 1.6) should be detected by rotating the interferometer through  $90^\circ$  in a horizontal plane, such that the two beams exchange roles. Then

$$\Delta d \equiv c\Delta t \sim 10^{-7} \text{ m for } L = 10 \text{ m and } (v/c)^2 \sim 10^{-8}.$$

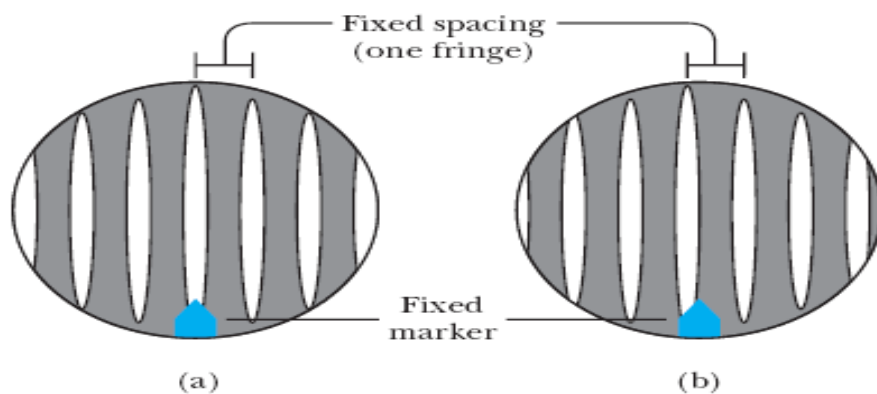

**Figure 1.6: Interference fringe schematic showing (a) fringes before rotation and (b) expected fringe shift after a rotation of the interferometer by  $90^\circ$ .**

The corresponding fringe shift is equal to this path difference divided by the wavelength of light,  $\lambda$ , because a change in path of 1 wavelength corresponds to a shift of 1 fringe.

$$\text{Shift} = \frac{2Lv^2}{\lambda c^2}$$

Specifically, using light of wavelength 500 nm, and  $\Delta d = 2.2 \times 10^{-7} \text{ m}$  we find a fringe shift for rotation through  $90^\circ$  of

$$\text{Shift} = \frac{\Delta d}{\lambda} = \frac{2.2 \times 10^{-7} \text{ m}}{5.0 \times 10^{-7} \text{ m}} \approx 0.40$$

**Result:** The precision instrument designed by Michelson and Morley had the capability of detecting a shift in the fringe pattern as small as 0.01 fringe. However, *they detected no shift in the fringe pattern.*

### Results

□ Using the Earth's orbital speed as:  $V = 3 \times 10^4 \text{ m/s}$

● together with  $\ell_1 \approx \ell_2 = 1.2 \text{ m}$

● So that the time difference becomes  $\Delta t' - \Delta t \approx v^2(\ell_1 + \ell_2)/c^3 = 8 \times 10^{-17} \text{ s}$

□ Although a very small number, it was within the experimental range of measurement for light waves.

### Michelson's Conclusion

● Michelson noted that he should be able to detect a phase shift of light due to the time difference between path lengths but found none.

● He thus concluded that the hypothesis of the stationary ether must be incorrect.

● After several repeats and refinements with assistance from Edward Morley (1893-1923), again *a null result*.

● ***Thus, ether does not seem to exist!***



## Possible Explanations

● Many explanations were proposed but the most popular was the *ether drag* hypothesis.

- This hypothesis suggested that the Earth somehow “dragged” the ether along as it rotates on its axis and revolves about the sun.

This was contradicted by *stellar aberration* wherein telescopes had to be tilted to observe starlight due to the Earth’s motion. If ether was dragged along, this tilting would not exist.

The Michelson-Morley experiment has been refined and repeated many times. Several of these results from the period 1881-1930 are summarized in figure (6). On the vertical axis we plot the observed fringe shift and on the horizontal axis we plot the expected fringe shift as calculated from the Galilean transformation. If the speed of light is constant, then zero fringe shift is expected. In practice a small fringe shift is observed due to the finite precision of the experimental apparatus.

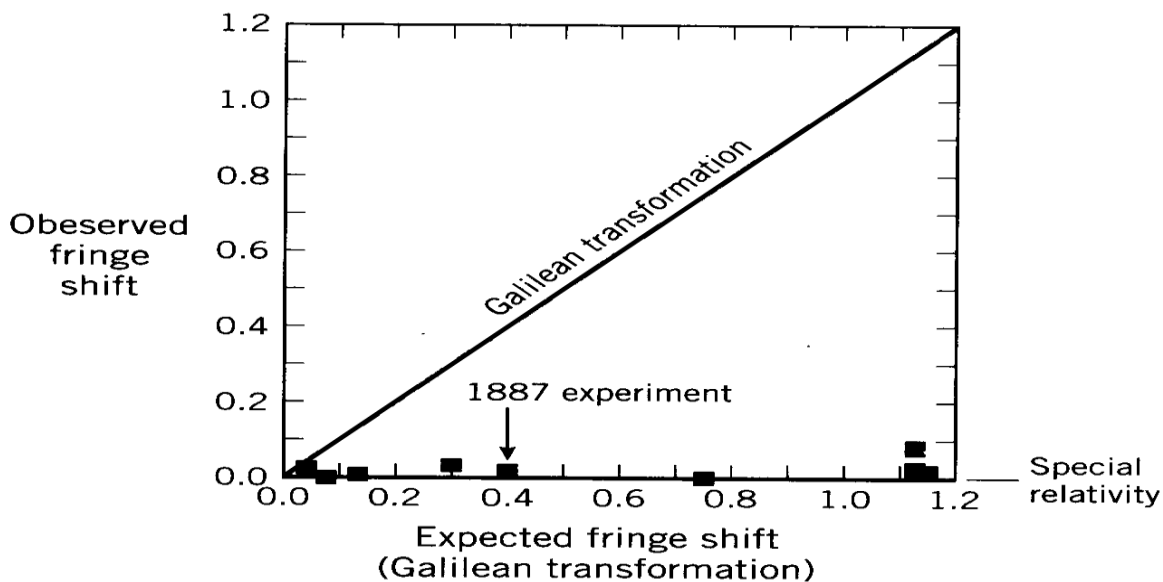

The difficulties raised by this null result were tremendous, not only implying that light waves were a new kind of wave propagating without a medium but that the Galilean transformations were flawed for inertial frames moving at high relative speeds. The stage was set for Albert Einstein, who solved these problems in 1905 with his special theory of relativity.

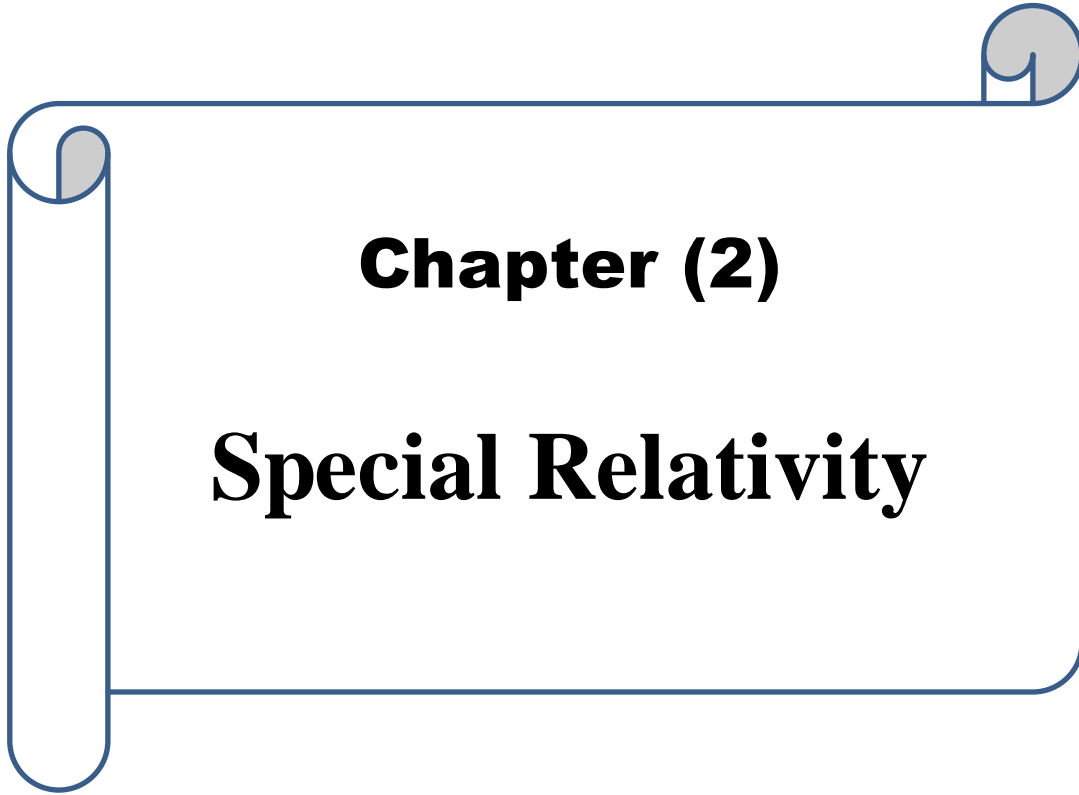

**Chapter (2)**

**Special Relativity**

## Chapter (2) : Special Relativity

### Special Relativity

#### Difference between the special and general theories of

#### The special theory of relativity

- The special theory of relativity is based on two ideas: all observers measure the same speed of light in a vacuum, regardless of their speed relative to the light source; and there is no absolute frame of reference.
- To a stationary observer watching an object travelling at close to the speed of light: time appears to slow down; mass appears to increase, and length in the direction of travel appears to decrease.
  - Because all motion is relative, an observer travelling at close to the speed of light (relative to a ‘stationary’ observer) will see that time, mass and length for a stationary observer have all changed.
- Objects with mass cannot reach or exceed the speed of light.
- Energy and mass are equivalent ( $E = mc^2$ ).

#### The General theory of relativity

- Space and time merge into four-dimensional spacetime.
- Large masses distort spacetime.
- Gravity results from the distortion of spacetime.
- Gravity causes light to bend towards large masses because of the distortion of spacetime.
- Time runs slower in areas where the gravitational field is stronger. Einstein versus Newton  
in areas where the gravitational field is stronger. Einstein versus Newton

### Postulates of special relativity:

1. **The Principle of Relativity:** All the laws of physics have the same form in all inertial reference frames.

In other words, covariance applies to electromagnetism (there is no ether) as well as to mechanics.

2. **The Constancy of the Speed of Light:** The speed of light in vacuum has the same value,  $c = 3.00 \times 10^8$  m/s, in all inertial frames, regardless of the velocity of the observer or the velocity of the source emitting the light.

This postulate is in fact more or less required by the first postulate. If the speed of light was different in different frames, the Maxwell equations governing the propagation of light would have to be frame-dependent.

In fact, Einstein said he was completely unaware of the MM experiment at the time he proposed his postulates. He was just thinking about the theory of light as being absolute and frame independent.

These two apparently simple postulates imply dramatic changes in how we must visualize length, time and simultaneity.

1. The distance between two points and the time interval between two events both depend on the frame of reference in which they are measured.
2. Events at different locations that occur simultaneously in one frame are not simultaneous in another frame moving uniformly with respect to the first.

To see what exactly is true, we need to first think about how an inertial reference frame is defined. We use a coordinate grid and a set of synchronized clocks throughout all space.

As an aside, we should note that we are already questioning that such a picture actually exists when looking at very tiny distance scales where effects of *quantum gravity* are expected to enter.

An inertial reference frame is probably only an effective description that is only valid up to the Planck mass scale.

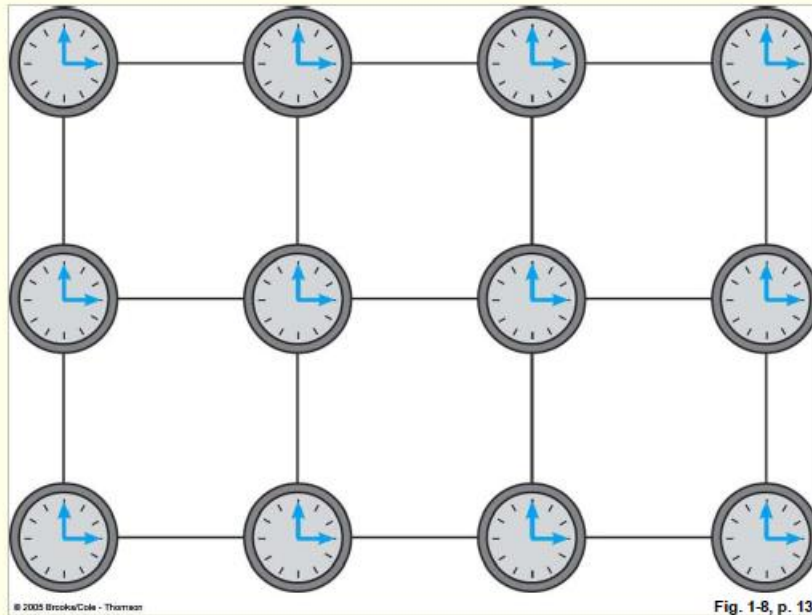

**Figure 3: Picture of an inertial reference frame.**

### **Success or Advantages of Special Relativity Postulates:**

1. No absolute time, motion or space, rather ( space - time ) spacetime
2. Lengths contract at velocities approaching  $c$  relative to stationary observers.
3. Infinitely many inertial frames of reference, each one in relative motion to each other
4. Each inertial frame has its own time dilation
5. All laws of physics are the same in all inertial frames of reference which leads to the invariance of the speed of light,  $c$
6. Speed of light is finite ( information is finite transmitted )
7. All possibilities of unbounded, relative motion with upper limit of velocities of bodies and particles held at  $c$ , speed of light
8. Newton's Law of Universal Gravitation is only true as an approximation of physical reality for relative velocities  $v \ll c$
9. Inertial frames of reference are related by (Fitzgerald -) Lorentz Transformation rules

10. Conservation Laws of energy, mass and momentum are maintained but in relativistic terms with finite  $c$

11. Energy and mass are equivalent, force being a manifestation of energy

Let's return to the concept of time.

### Example A

Suppose time were uniquely definable and the same in all frames.

Consider a (small) plane moving at speed  $v$  (and very close to ground) in the  $+x$  direction relative to someone on the ground.

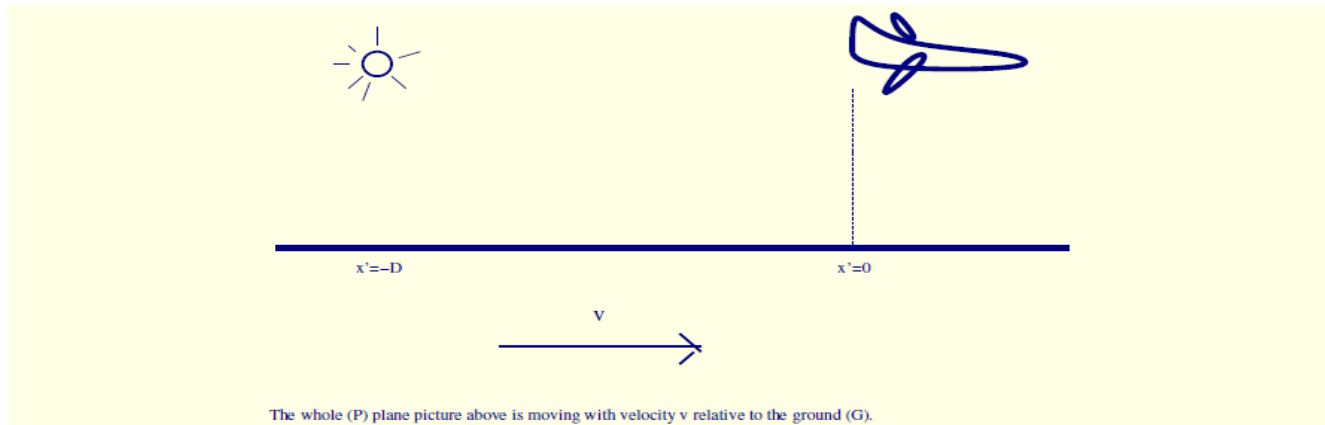

Figure 4: The frame for a plane moving relative to the earth.

When the plane is at  $x' = 0$  someone at  $x' = -D$  flashes a light (these are the plane's coordinates). If time is universal then both  $P$  (plane) and  $G$  (ground) agree that the light flashes at a certain time, say  $t = t' = 0$ .

The time at which  $P$  thinks the light arrives at  $x' = 0$  (the plane never moves from  $x' = 0$  – he is at rest in his coordinate system) is  $t' = D/c$  (assuming light travels with velocity  $c$ ).

The time at which  $G$  thinks the light arrives at the plane would also be  $t = t' = D/c$  if time is universal. However, since the plane has moved

by an amount

$$\text{extra distance} = v \frac{D}{c} \quad (9)$$

according to  $G$  while the light has been traveling, the  $G$  observer concludes that the velocity of light is

$$\frac{\text{distance}}{\text{time}} = \frac{D + v \frac{D}{c}}{\frac{D}{c}} = v + c. \quad (10)$$

Well, this contradicts Einstein's postulates of relativity. It has to be that the clocks in the  $G$  and  $P$  frames are not synchronized in the manner we assumed or that distance scales are not the same in the two frames. In fact, both apply.

### Example B

- Consider 2 observers  $A$  and  $B$  that pass one another, with, say,  $B$  moving with velocity  $v$  in the  $x$  direction relative to  $A$  who we envision is at rest in "our" frame.

A burst of light is emitted as they pass one another. Each claims that the light travels outward in spherical waves with velocity  $c$ , with the spheres centered on themselves.

A modern day application is that a terrorist dropping a bomb (that immediately detonates) from a fast moving car might hope to quickly leave behind the destruction and explosion. But, to the extent that electromagnetic radiation was the only consideration, he would always be at the center of the explosion no matter how fast he was moving in some other frame.

- This is completely different from what one would conclude if light traveled in a medium like water.

Consider two boats, one ( $A$ ) at rest in a pond, the other ( $B$ ) moving rapidly (but without creating any wake) relative to the first boat.

*B* drops a rock in the pond as he passes *A*.

Because *A* is at rest in the pond, the ripples spread out in concentric circles from his position and *B*, looking back, agrees. Indeed, he could even go faster than the ripples, in which case they would never catch up to him.

Putting Einstein's visualization into mathematical language, we would say that the expanding spheres of electromagnetic radiation should obey

$$x^2 + y^2 + z^2 = c^2 t^2 \quad \text{for } A; \quad x'^2 + y'^2 + z'^2 = c^2 t'^2 \quad \text{for } B. \quad (11)$$

These are the equations defining how each sees the light fronts (in his own frame) emanating from the initial flash.

Demanding that the transformation from the unprime to prime system be a linear transformation<sup>1</sup> with coefficients determined only by the fundamental constant  $c$  and by the relative velocity of the two frames  $v$ , and requiring that  $x' = 0$  must correspond to  $x = vt$  (see Fig. 1), there is only one solution, the so-called *Lorentz transformation*:



## Transformation between systems

The constancy of the speed of light is not compatible with Galilean transformations. Consider a wave front starting at the origin of two frames whose origin coincide at  $t = 0$ . In terms of the coordinates of the two frames

$$x^2 + y^2 + z^2 = c^2 t^2$$

$$x'^2 + y'^2 + z'^2 = c^2 t'^2$$

According to the Galilean transformation

$$x' = x - vt$$

$$y' = y, \quad z' = z, \quad t' = t$$

$$\Rightarrow x'^2 + y'^2 + z'^2 = (x^2 - 2xvt + v^2 t^2) + y^2 + z^2 \neq c^2 t^2 \quad (A.6)$$

Therefore the Galilean transformation is not compatible with the constancy of the speed of light

There are a couple of extra terms ( $-2xvt + v^2 t^2$ ) in the primed frame.

### 4. Lorentz Transformation

Now we wish to derive the transformation equations for the displacement and velocity of an object—the relativistic version of the Galilean transformation equations. In what follows, we'll

be setting  $\gamma = \frac{1}{\sqrt{1 - \frac{v^2}{c^2}}}$ .

a. Two frames

Consider two inertial reference frames, S & S' and assume that  $O = O'$  at  $t' = 0$ .

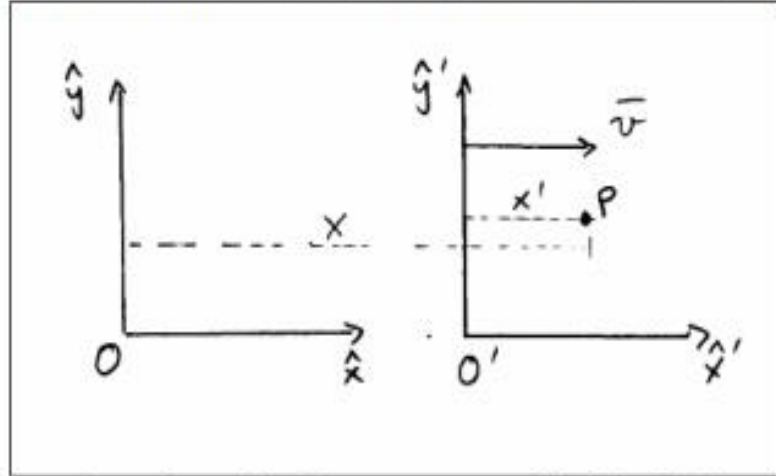

What is the x-distance from O to the point P, as measured in the S' frame?

In effect, then, we'll have  $\Delta t = t$  and  $\Delta t' = t'$ .

$$l = x' + vt'$$

In the S frame,  $l = x$ , so  $l' = \frac{x}{\gamma}$  also. Set 'em equal.

$$\frac{x}{\gamma} = x' + vt'$$

$$x = \gamma(x' + vt')$$

On the other hand, as measured in the S frame,  $x = vt + \frac{x'}{\gamma}$ . Set them equal.

**Lorentz Transformation can be written as :**

$$X = \frac{x' + Vt'}{\sqrt{1 - V^2 / C^2}}$$

$$y = y'$$

$$Z = Z'$$

$$t = \frac{t' + Vx' / C^2}{\sqrt{1 - V^2 / C^2}}$$

**Inverse  
relations**

$$x' = \frac{x - Vt}{\sqrt{1 - V^2 / C^2}}$$

$$y' = y$$

$$Z' = Z$$

$$t' = \frac{t - Vx / C^2}{\sqrt{1 - V^2 / C^2}}$$

### Lorentz Transformation for velocity can be written as :

$$\therefore u_x = dx/dt \quad , \quad u_y = dy/dt \quad , \quad u_z = dz/dt$$

$$\therefore u_x = \frac{dx}{dt} = \frac{\gamma(dx' + Vdt')}{\gamma[dt' + (V^2/C^2)dx']} = \frac{u_x' + V}{1 + u_x' \frac{V}{C^2}}$$

$$u_y = \frac{dy}{dt} = \frac{dy'}{\gamma[dt' + (V^2/C^2)dx']} = \frac{u_y'}{\gamma(1 + u_x' \frac{V}{C^2})}$$

$$u_z = \frac{dz}{dt} = \frac{dz'}{\gamma[dt' + (V^2/C^2)dx']} = \frac{u_z'}{\gamma(1 + u_x' \frac{V}{C^2})}$$

### The Inverse Lorentz velocity transformation

$$\therefore u_x = \frac{dx'}{dt'} = \frac{u_x - V}{1 - u_x V / C^2}$$

$$\therefore u_y = \frac{dy'}{dt'} = \frac{u_y - V}{\gamma(1 - u_x V / C^2)}$$

$$\therefore u_z = \frac{dz'}{dt'} = \frac{u_z - V}{\gamma(1 - u_x V / C^2)}$$

Note that if  $v/c \ll 1$ , then  $\gamma \rightarrow 1$  and we get back the Galilean approximation.

But, if  $v/c \rightarrow 1$ , then  $\gamma \gg 1$  and there are big changes.

### properties of $\gamma$

Recall  $\beta = v/c < 1$  for all observers.

- 1)  $\gamma \geq 1$  equals 1 only when  $v = 0$ .
- 2) Graph of  $\beta$ : (note  $v \neq c$ )

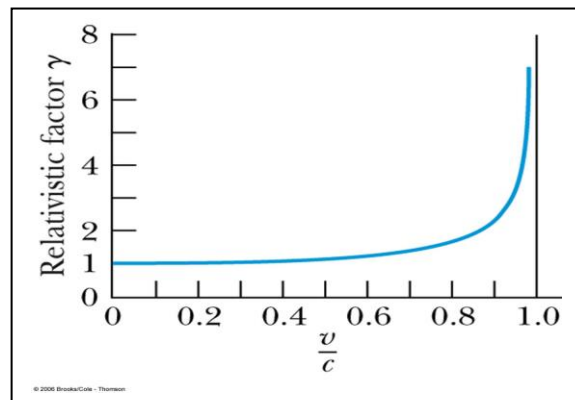

### An important consequence

Using the Lorentz transform equations, we can easily show that  $x^2 - c^2t^2 = x'^2 - c^2t'^2$ , for any choices of  $x, t$  and the corresponding values of  $x', t'$ .

$x_4 \cdot x_4 \equiv c^2t^2 - x^2 - y^2 - z^2$ . In the prime frame,  $x'_4 = (ct', x', y', z')$  and  $x'_4 \cdot x'_4 \equiv c^2t'^2 - x'^2 - y'^2 - z'^2$ .

We see that a restatement of the Lorentz transformation equations, equivalently Einstein's frame-independent for the velocity of light, is to say that **the square of a 4-vector is frame-independent**.

### c. 4-vectors

Suppose that when  $O = O'$ , a flash of light is emitted from the origin  $O$ . In the  $S$  frame, the distance the light wave front travels in time  $t$  is  $r^2 = x^2 + y^2 + z^2 = c^2t^2$ . Measured in the  $S'$  frame, it's  $r'^2 = x'^2 + y'^2 + z'^2 = c^2t'^2$ . Subtract the second expression from the first and collect the  $S$  frame on one side of the equal sign, the  $S'$  frame on the other side.

$$r^2 - r'^2 = c^2t^2 - c^2t'^2$$

$$r^2 - c^2t^2 = r'^2 - c^2t'^2$$

There is this quantity, a generalized displacement (call it  $s$ ) which is the same in the two inertial reference frames.

$$s^2 = s'^2$$

We see that the quantity  $(ict)$  "acts like" a component of displacement along a fourth axis. The *interval* between any two events in space-time is  $\Delta s^2 = \Delta x^2 + \Delta y^2 + \Delta z^2 - c^2\Delta t^2$ . The interval is invariant under the Lorentz Transformation. That is, as measured in any two inertial frames,  $\Delta s^2 = \Delta s'^2$ . This is an extension of the invariance of lengths under a rotation of the coordinate axes.

example:

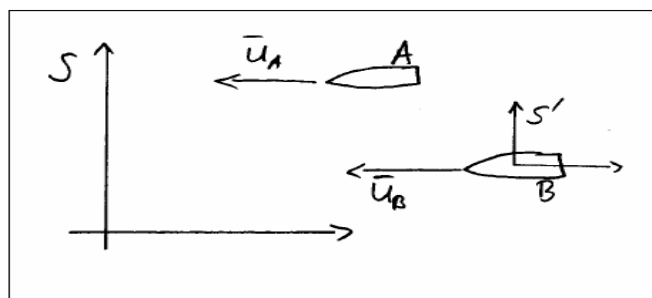

$u_A = -0.5c$  and  $u_B = -0.8c$ , both as measured in the  $S$  frame. The  $S'$  frame rides along with spaceship  $B$ . Therefore,  $\vec{v} = \vec{u}_B$ .

$$u'_A = \frac{u_A - v}{1 - \frac{v}{c^2}u_A} = \frac{-0.5c - (-0.8c)}{1 - \frac{0.8c}{c^2}0.5c} = \frac{c}{2}$$

Be careful with the directions of the velocities.

Note that when  $u \ll c$  and  $v \ll c$ , then  $\frac{vu}{c^2} \rightarrow 0$  and  $u' = u - v$ . On the other hand, if  $u = c$ ,

$$\text{then } u' = \frac{c - v}{1 - \frac{cv}{c^2}} = \frac{c \left(1 - \frac{v}{c}\right)}{1 - \frac{v}{c}} = c.$$

## **Important successes of the special relativity**

### **1- Time dilation**

The most important outcome of Lorentz transformation that ( $t' \neq t$ ) . This means that, if we put a clock inside different coordinates, the rate of its rotation will change .

To explain the meaning of time dilation using **Einstein train experiment** , if there is a light signal emitted from a bulb light exist at train's car surface and incident on a mirror fixed at top roof of the car and reflected back the surface. The train moves with velocity ( $v$ ) .

**Event** : Is the Light Signal , studying its propagation from the starting point of its emission until its reflection from the fixed mirror at roof of the train's car surface .

**Observers**  $O$  and  $O'$  : Suppose there are two observers, one exist at fixed inertial reference frame ( $O'$ ). and the other exist inside the train's car ( $O$ ).

### **First: Measurements of the Observer at a fixed inertial reference frame ( $O'$ ).**

The observer ( $O'$ ). Measures the travel of time by dividing the resultant distance by the speed of light .

The  $O'$  observer will measure the time of this event by dividing resultant distance by the speed of light .

**Notes** : The  $O'$  observer is fixed with respect to the event , its position coordinates doesn't change between the starting and ending the event as shown in the down fighter.

Travel distance equals twice height of roof of the train's car ( $2L'$ ) and the event time period with respect to  $O'$  observer calculated as :

$$t' = \frac{2L'}{C} \text{-----(1)}$$

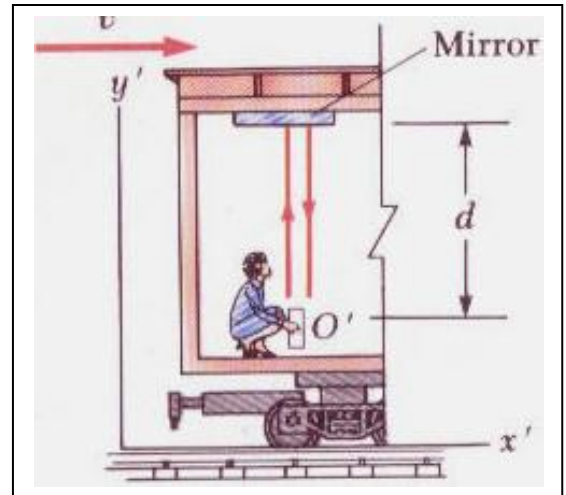

### Second: Measurements of the moving observe (O).

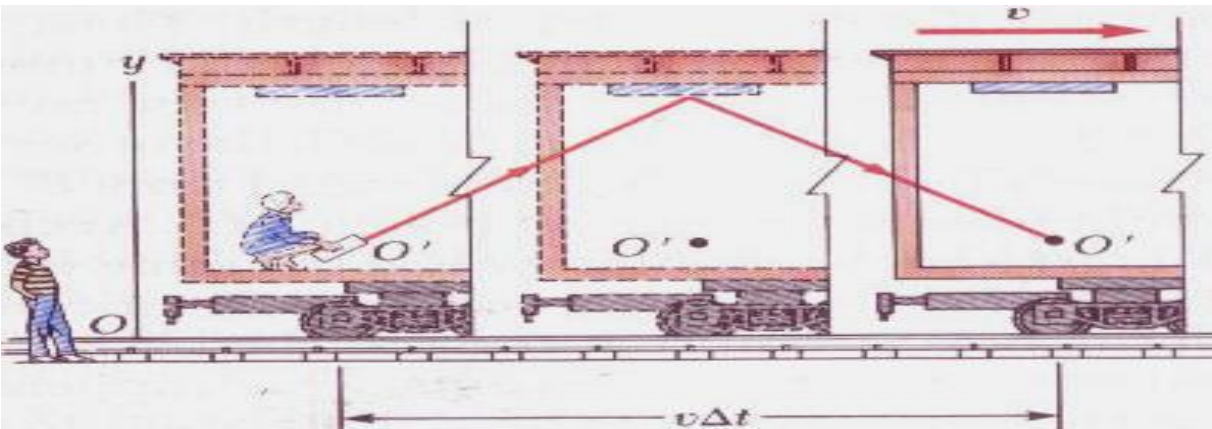

The  $O$  observer carried out his measurements, but he moves with respect to the event ( or the event moves with respect to him) . Here, the initial and final point of event occurs at two different positions with respect to the  $O$  observer as shown in a given fig. During this time period of the event , the train travel forward to the right a distance ( $vt$ ) , where  $t$  is event time measured by the  $O$  observer.

This Fig. illustrate the path of light signal with respect to the  $O$  observer , here the path length of the light signal is greater than its path with respect to the  $O'$  observer.

From the second postulate of special relativity, the velocity of the light signal is constant (not change) with respect to the tow observers and equals the speed of light

(c) . Because the path of the light signal with respect to the O observer is longer than that of the O' observer, then the measured time by O observer is greater than that of O' observer.

### Mathematical Forms between the measurements of the two observers O and O'

Consider the bold line represents the path of signal light which measured by O' observer, and dashed line represents the path of light measured by O observer . In order to the light travel the distance from the surface of train's car to the

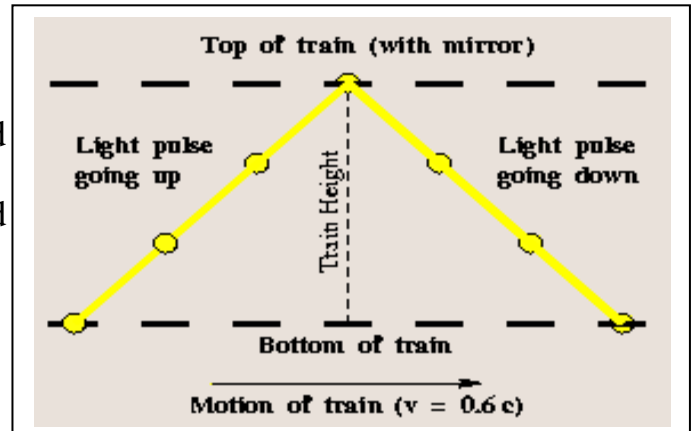

mirror in the roof of the car , it spend a half ( $t/2$ ) of total time. Using **mathematical Fesajorse** theory on the left triangle. Considering  $L'$  is the height of the train's car as follow :

$$\left(\frac{ct}{2}\right)^2 = \left(\frac{vt}{2}\right)^2 + L'^2$$

$$\Rightarrow \frac{c^2 t^2}{4} = \frac{v^2 t^2}{4} + L'^2$$

$$\Rightarrow \frac{c^2 t^2}{4} - \frac{v^2 t^2}{4} = L'^2 \Rightarrow \frac{t^2}{4}(c^2 - v^2) = L'^2$$

$$\Rightarrow t^2(c^2 - v^2) = 4L'^2 \Rightarrow t^2 = \frac{4L'^2}{(c^2 - v^2)}$$

$$\Rightarrow t^2 = \frac{(2L')^2}{c^2(1 - v^2/c^2)} \Rightarrow t^2 = \frac{(2L')^2/c^2}{(1 - v^2/c^2)}$$

$$\Rightarrow t = \frac{2L'/c}{\sqrt{(1 - v^2/c^2)}} \text{----- (2)}$$

$$t' = \frac{2L'}{C} \text{.....from...Eq(2)}$$

We got the relation between time measurements of each observer

$$t = \frac{t'}{\sqrt{1 - \frac{v^2}{c^2}}} = \gamma \cdot t' \quad \text{----- (3)}$$

We put ;  $\gamma = 1/\sqrt{(1-v^2/c^2)}$

**Note** : Equation (3) represents the measured time dilation according to special relativity. Always the parameter,  $(\gamma) > 1$  , This leads to  $\Delta t' > \Delta t$  . e.g : this mean that the time which measured by a fixed observer is greater, while the moving watch its measured time seems to be delay with respect to a fixed observer.

The studies of time dilation are important in the emission of radiation processes, nuclear diffusion and interaction of primary particles, because their velain is smallerocities are much greater , because it close to the speed of light. This cause the changes in  $(\gamma)$  parameter values of are greater.

### **Important Notes :**

- 1- **Because the velocity of the train is smaller than the speed of light , this leads to  $\gamma > 1$  . For this reason, time measurements of  $O > O^{\sim}$  e.g :  $t < t'$  .**
- 2- **For velocities  $v \ll c$ , such as velocities of cars, train, rock . These velocities are smaller compared to light speed. This mack the calculation of the dominator in Eq (3) = 1 . This mack the measurements are equal fro the two observers, This means that dilation of time can not measured except at high velocities compared to light speed .**
- 3- **At high velocities , the moving observer watch with respect to the event , it measure long time than that of the fixed observer with respect to the event.**



#### 4- The proper Time, it is the measured time by the fixed observer with respect to the event.

##### Example

The lifetime of a *pion* in its own rest frame is  $\Delta t' = 2.6 \times 10^{-8}$  sec. Consider a pion moving with speed  $v = 0.95c$  in a lab—what will be measured as its lifetime in the lab?

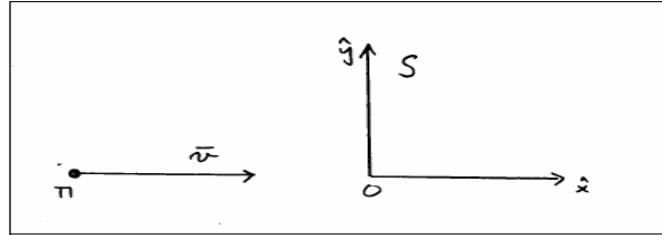

$$\Delta t = \frac{\Delta t'}{\sqrt{1 - \frac{v^2}{c^2}}} = \frac{2.6 \times 10^{-8} \text{ sec}}{\sqrt{1 - 0.95^2}} = \frac{2.6 \times 10^{-8} \text{ sec}}{0.312} = 8.33 \times 10^{-8} \text{ sec} .$$

The lifetime of a fast-moving particle is measured by noting how far it travels before decaying.

In this example  $\ell = v\Delta t = 0.95c \cdot 8.33 \times 10^{-8} \text{ sec} = 23.7 \text{ m}$ . In practice, we measure  $\ell$  and compute  $\Delta t$ .

#### c. Proper time

The *proper time* is the time interval measured by an observer for whom the two events occur at the same place, so that  $\Delta x' = \Delta y' = \Delta z' = 0$ .

### Space contraction

Consider the time for a pulse parallel to the system velocity to do a round trip:

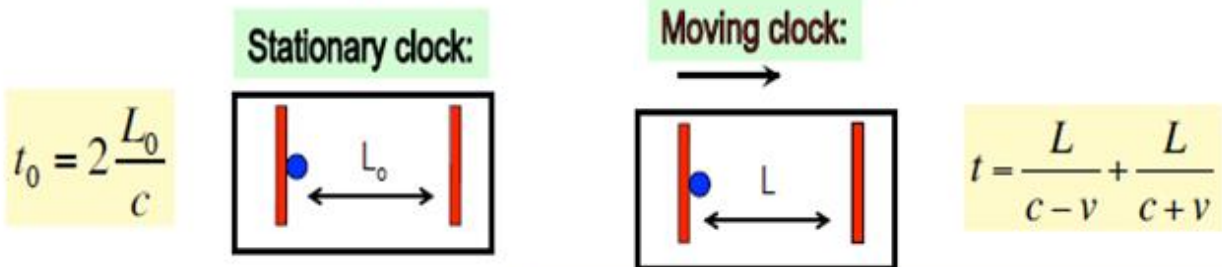

$$\rightarrow L = L_0 \cdot \sqrt{1 - v^2 / c^2}$$

An observer moving along an object will find it shorter than it would be if the observer was standing still.

## Length Contraction (Lorentz Contraction)

- ◆ Suppose that a rod lies at rest along the  $x'$ -axis of frame  $S'$ . Let the left end of the rod be at  $x'_1$  and the right end at  $x'_2$ , so that the length of the rod as measured in frame  $S'$  is  $L' = x'_2 - x'_1$ . What is the length of the rod as measured in frame  $S$ ?

- ◆ From Lorentz transformation

$$x' = \frac{x - ut}{\sqrt{1 - u^2/c^2}}$$

we find that

$$x'_2 - x'_1 = \frac{(x_2 - x_1) - u(t_2 - t_1)}{\sqrt{1 - u^2/c^2}}$$

and with  $t_1 = t_2$  (naturally both ends of the rod are measured at the same time in frame  $S$ )

$$L' = \frac{L}{\sqrt{1 - u^2/c^2}}$$

Which is shorter,  $L$  or  $L'$ ?

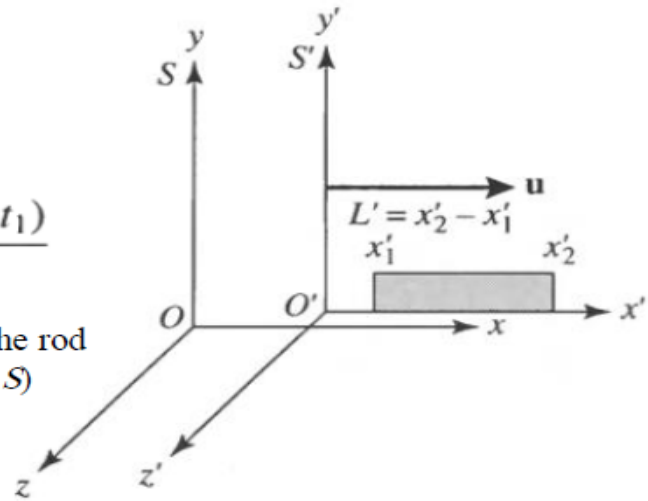

## Length Contraction and Proper Length

- ◆ Once again, we are simply applying an additional postulate to Newtonian physics, that is Einstein's 2<sup>nd</sup> postulate.
- ◆ Consider the light clock described before, but now with one clock oriented orthogonal to and the other clock parallel to the direction of motion of the  $S'$  frame. They must both tick at the same rate as measured by an observer in the  $S$  frame (as time can only run at one rate in a given reference frame), although suffering from the effect of time dilation.
- ◆ According to the observer in the  $S$  frame, if there is no length contraction, the light pulse of the orthogonally-oriented clock makes a round trip in a shorter time interval than the light pulse of the parallel-oriented clock. (Imagine that the  $S'$  frame is stationary and the  $S$  frame is being carried to the left by a river: the cross-stream swimmer makes a round trip faster than the upstream-downstream swimmer.) This cannot happen as both clocks tick at the same rate, implying that the parallel-oriented clock must suffer length contraction.

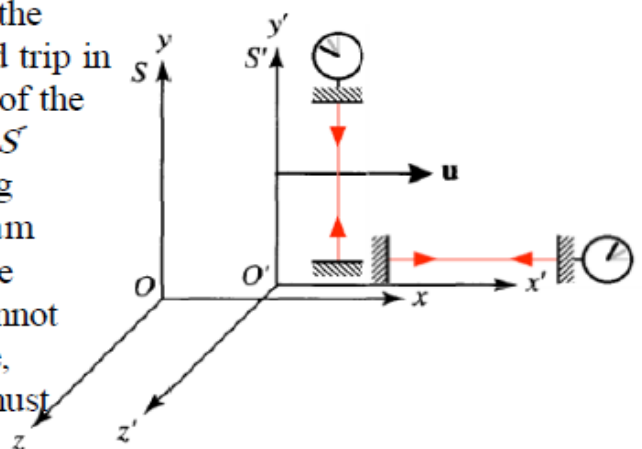

- ◆ Let us return to the derivation for the length of a rod in frame  $S'$  as measured by an observer in frame  $S$  where the rod aligned in the direction of motion:

$$L = L' \sqrt{1 - u^2/c^2}$$

- ◆ Let us call  $L' = L_{\text{rest}}$  as the rod is at rest in frame  $S'$ . Let us call  $L = L_{\text{moving}}$  as the rod is moving in frame  $S$ . Then

$$L_{\text{moving}} = L_{\text{rest}} \sqrt{1 - u^2/c^2}.$$

- ◆ Lengths (distances) are therefore measured differently by two observers in relative motion. Who measures the longer length, an observer at rest or moving with respect to the object?

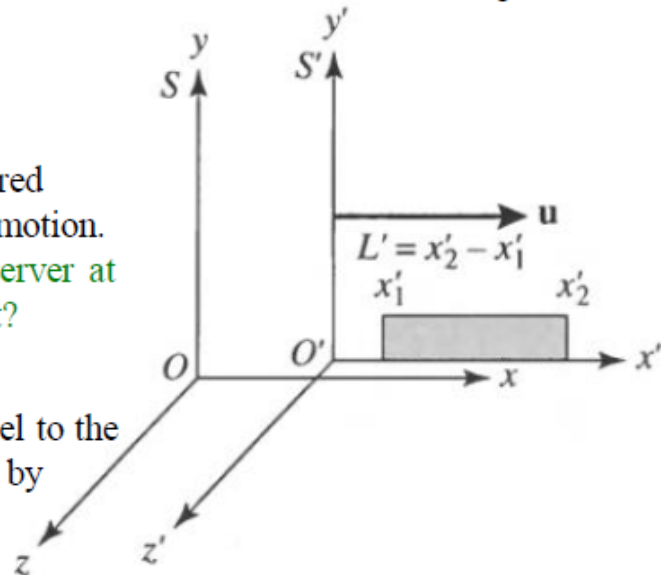

- ◆ Note that only lengths (distances) parallel to the direction of relative motion are affected by length contraction. Lengths (distances) perpendicular to the direction of relative motion remain unchanged

### Simultaneity

#### a. Space-time

Each event has associated with it four numbers:  $x, y, z$  coordinates and a “value of time” which we read off a clock located at that spatial location. There is no central universal clock, rather there is a clock at every point in space.

#### b. Synchronization

We would like all clocks in a reference frame to display exactly the same reading simultaneously, but can this be arranged? Only by the exchange of signals, which is another way of saying only in terms of intervals. However, as we have seen, intervals are not the same for observers in different inertial reference frames. Therefore, the concept of two events being simultaneous has no absolute meaning.

#### c. Non-simultaneity

Two events viewed as simultaneous in one frame will not be seen as occurring simultaneously in another frame.

example: a train moving with constant velocity on a straight, smooth track. One observer rides on the train, the other observer stands beside the track.

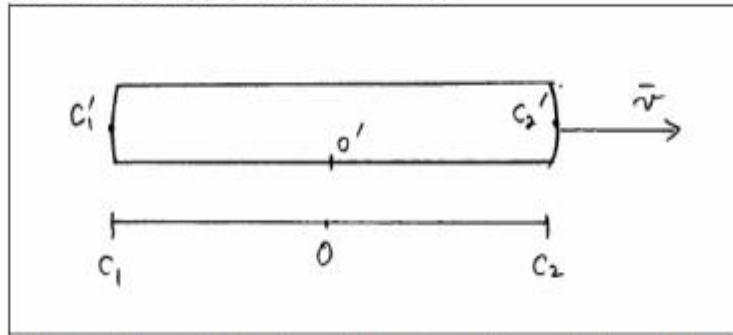

Flashes of light are emitted at the points  $C_1$  and  $C_2$  when the origins ( $O$  &  $O'$ ) of the two frames coincide. To the trackside observer at  $O$ , the flashes are simultaneous. To the observer on the train, however, the flash emitted at  $C'_2$  is received before the flash emitted at  $C'_1$ . Yet both observers measure the same speed of light,  $c$ .

## Twin Paradox

### The Set-up

Twins Mary and Frank at age 30 decide on two career paths: Mary decides to become an astronaut and to leave on a trip 8 light years (ly) from the Earth at a great speed and to return; Frank decides to reside on the Earth.

**The Problem** : Upon Mary's return, Frank reasons that her clocks measuring her age must run slow. As such, she will return younger. However, Mary claims that it is Frank who is moving and consequently his clocks must run slow.

**The Paradox** : Who is younger upon Mary's return?

### The Resolution

- 1) Frank's clock is in an **inertial system** during the entire trip; however, Mary's clock is not. As long as Mary is traveling at constant speed away from Frank, both of them can argue that the other twin is aging less rapidly.
- 2) When Mary slows down to turn around, she leaves her original inertial system and eventually returns in a completely different inertial system.

- 3) Mary's claim is no longer valid, because she does not remain in the same inertial system. There is also no doubt as to who is in the inertial system. Frank feels no acceleration during Mary's entire trip, but Mary does.
- 4) Frank's clock is in an **inertial system** during the entire trip; however, Mary's clock is not. As long as Mary is traveling at constant speed away from Frank, both of them can argue that the other twin is aging less rapidly.
- 5) When Mary slows down to turn around, she leaves her original inertial system and eventually returns in a completely different inertial system.
- 6) Mary's claim is no longer valid, because she does not remain in the same inertial system. There is also no doubt as to who is in the inertial system. Frank feels no acceleration during Mary's entire trip, but Mary does.

## **Spacetime**

- When describing events in relativity, it is convenient to represent events on a spacetime diagram.
- In this diagram one spatial coordinate  $x$ , to specify position, is used and instead of time  $t$ ,  $ct$  is used as the other coordinate so that both coordinates will have dimensions of length.
- Spacetime diagrams were first used by H. Minkowski in 1908 and are often called Minkowski diagrams. Paths in Minkowski spacetime are called worldlines.

## **Spacetime Interval**

Since all observers "see" the same speed of light, then all observers, regardless of their velocities, must see spherical wave fronts.

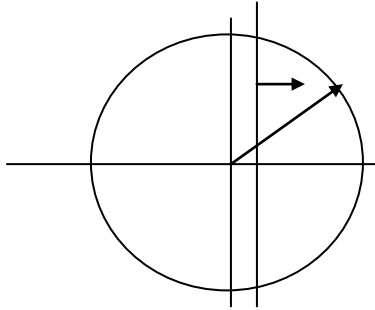

$$s^2 = x^2 - c^2 t^2 = (x')^2 - c^2 (t')^2 = (s')^2$$

**Spacetime Diagram**

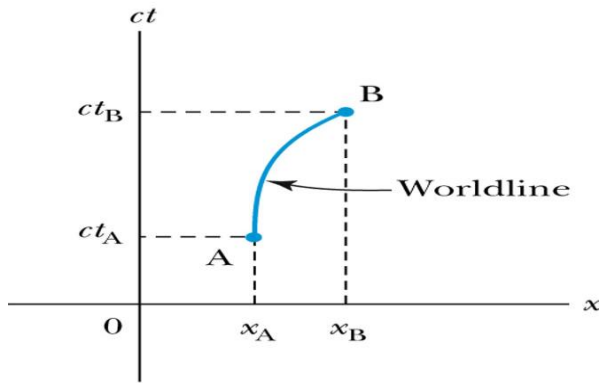

© 2006 Brooks/Cole - Thomson

**Particular Worldlines**

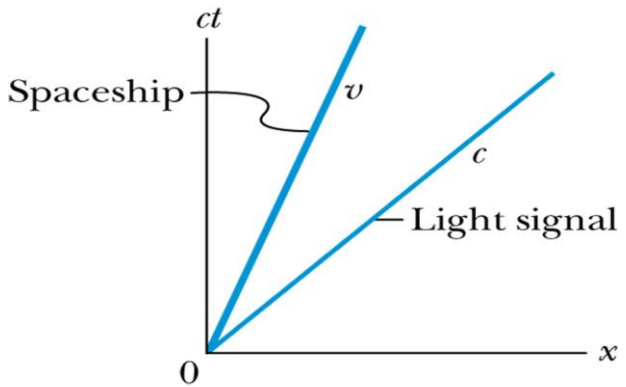

© 2006 Brooks/Cole - Thomson

**Worldlines and Time**

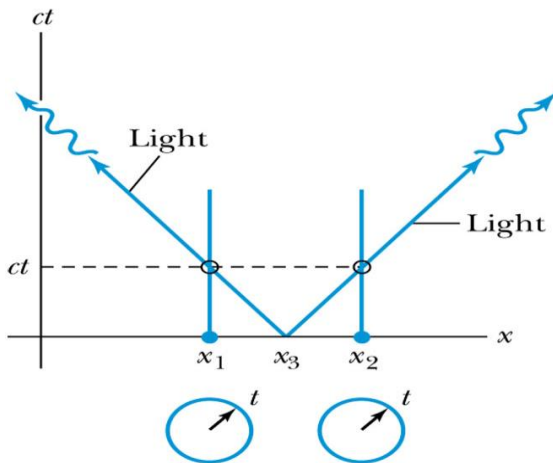

© 2006 Brooks/Cole - Thomson

**Moving Clocks**

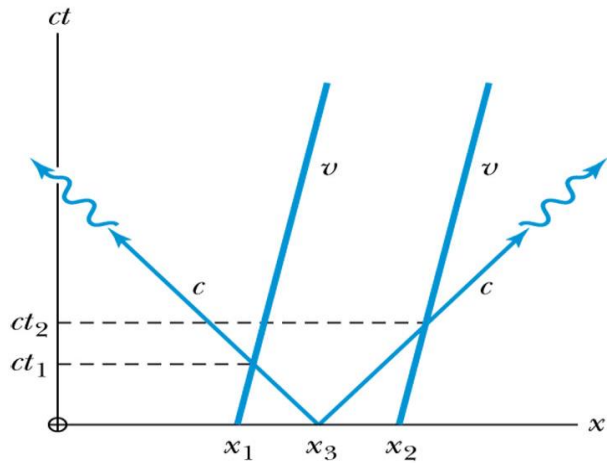

© 2006 Brooks/Cole - Thomson

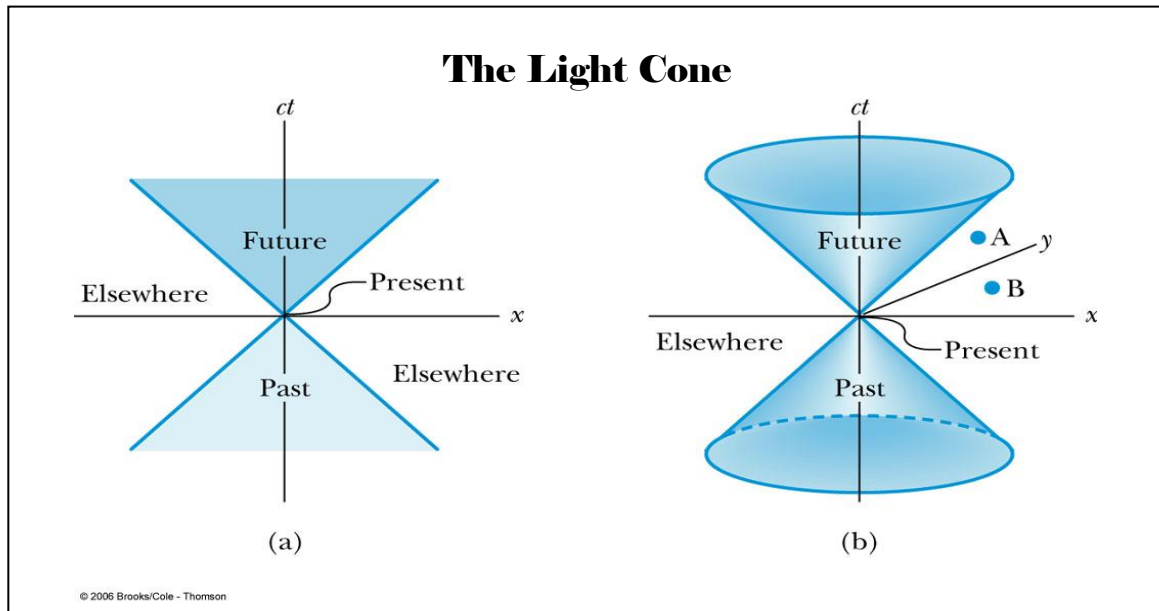

2

● If we consider two events, we can determine the quantity  $\Delta s$  between the two events, and we find that it is **invariant** in any inertial frame. The quantity  $\Delta s$  is known as **the spacetime interval** between two events.

There are three possibilities for the invariant quantity  $\Delta s^2$ :

- 1)  $\Delta s^2 = 0$ :  $\Delta x^2 = c^2 \Delta t^2$ , and the two events can be connected only by a light signal. The events are said to have a **lightlike** separation.
- 2)  $\Delta s^2 > 0$ :  $\Delta x^2 > c^2 \Delta t^2$ , and no signal can travel fast enough to connect the two events. The events are not causally connected and are said to have a **spacelike** separation.
- 3)  $\Delta s^2 < 0$ :  $\Delta x^2 < c^2 \Delta t^2$ , and the two events can be causally connected. The interval is said to be **timelike**.

## relativistic Doppler shift.

This is a particularly important application as it is the Doppler “red”-shift that we use to tell us that the universe is expanding from something like an initial big bang.

You are all familiar with the usual Doppler shift in which the pitch of sound for a whistle on a train headed towards you has a higher pitch than the whistle sound when the train is moving away.

This is because successive waves emitted by a source moving towards you are closer together than normal because of the advance of the source — and since their separation is the wavelength of sound, the corresponding frequency is higher.

The formula in the case of sound is probably something you have derived in an earlier course.

$$f = f_0 \left( \frac{1 + \frac{v}{c}}{1 - \frac{V}{c}} \right), \quad (32)$$

where  $f_0$  is the frequency of the sound as measured by the source itself,  $f$  is the frequency as measured by the observer,  $c$  is the speed of sound,  $v$  is the speed of the observer (+ for motion toward source), and  $V$  is the speed of the source (+ for motion toward the observer).

This classical Doppler effect evidently varies depending upon whether the source, the observer, or both are moving.

- This does not violate relativity because sound does travel in a medium — unlike light.
- Since light does not travel in a medium, the light wave Doppler effect will be different.

It can be derived using the concepts of time dilation. My derivation is an alternative approach to that given in the book. Note, in particular, that the book assumes that the source is moving towards the observer.

Imagine a light source as a clock that ticks  $f_0$  times per second and emits a light wave peak at each tick. The proper time in the source rest frame between ticks is  $t_0 = 1/f_0$ .

Consider a source at rest and an observer moving away from it with velocity  $v$ . The interval between ticks as seen by this observer is given by time dilation:  $t = \gamma t_0$

As viewed by the observer, he travels the distance  $vt$  away from the source between ticks.

Thus, each tick takes a time  $vt/c$  longer to reach him than the simple



time  $t$  between ticks.

The total time between the arrival of successive peaks (successive ticks) is then

$$\begin{aligned} T &= t + \frac{vt}{c} = t\left(1 + \frac{v}{c}\right) = \gamma t_0\left(1 + \frac{v}{c}\right) \\ &= t_0 \frac{1 + \frac{v}{c}}{\sqrt{1 - \frac{v^2}{c^2}}} = t_0 \sqrt{\frac{1 + \frac{v}{c}}{1 - \frac{v}{c}}}. \end{aligned} \quad (33)$$

The corresponding frequency of the ticks or wave peaks is just the inverse:

$$f(\text{receding case}) = \frac{1}{T} = \frac{1}{t_0} \sqrt{\frac{1 - \frac{v}{c}}{1 + \frac{v}{c}}} = f_0 \sqrt{\frac{1 - \frac{v}{c}}{1 + \frac{v}{c}}} \quad (34)$$

- Now, although I derived this for an observer moving away from the source, the same result applies if the source moves away from the observer.
- You should also note that the frequency shift depends only on the relative velocity of the source and observer. One does not need to reference any medium in which light travels.
- Since wavelength and frequency are inversely related,  $f\lambda = c$ , the shift in  $\lambda$  obeys the inverse formula.

### Example:

Determining the speed of recession of the Galaxy Hydra.

A certain absorption line that would be at  $\lambda_0 = 394 \text{ nm}$  were Hydra at rest, is shifted to  $\lambda = 475 \text{ nm}$  according to observations on earth.

We use

$$\lambda = \sqrt{\frac{1 + \frac{v}{c}}{1 - \frac{v}{c}}} \lambda_0 \quad (35)$$

to find that

$$\frac{v}{c} = \frac{\frac{\lambda^2}{\lambda_0^2} - 1}{\frac{\lambda^2}{\lambda_0^2} + 1} = 0.185. \quad (36)$$

Therefore, Hydra is receding from us with a velocity of  $v = 0.185 c = 5.54 \times 10^7 \text{ m/s}$ .

\*\*\*Show tape #42 on space-time diagram starting at 20 min mark. \*\*\*\*

### Solved Problems

**Problem (1) :** The time age for nuclear particle before transferring to another form equals  $1.8 \times 10^{-8}$  sec, when it is at rest in laboratory research. What is the time age of this particle when its velocity becomes 0.95 of light speed?

Solution

IN this case ,  $v = 0.95 c$  , Then :

$$\Delta t' = \frac{1.8 \times 10^{-8}}{\sqrt{1 - \left(\frac{0.95 c}{c}\right)^2}} = 5.76 \times 10^{-8} \text{ Sec.}$$

The result shows that the time age of the particle equals three times its time age when it becomes at rest

**Problem (2) :** what is the speed of the airplane, which has a clock that rotates by one second delay with another clock that exists on Earth frame ?.

Solution

Put :  $\Delta t = 3600 \text{ Sec}$  &  $\Delta t' = 3601 \text{ Sec}$

$$\therefore 3601 = \frac{3600}{\sqrt{1 - \left(\frac{v}{c}\right)^2}}$$

$$\sqrt{1 - \left(\frac{v}{c}\right)^2} = \frac{3600}{3601} \Rightarrow \left(\frac{v}{c}\right)^2 = 1 - \left(\frac{3600}{3601}\right)^2$$

$$v = \sqrt{1 - \left(\frac{3600}{3601}\right)^2} \times c \Rightarrow v = 7.1 \times 10^6 \text{ m/Sec}$$

**Problem (3) :** If the average age time of the Meson particle ( $\mu$ ) which moves by a velocity  $0.9 c$  is  $6 \times 10^{-6}$  Sec . Calculate its average age in a steady frame reference.

Solution

$$\Delta t' = 6 \times 10^{-6} \text{ Sec} , \quad v = 0.9 c$$

$$\begin{aligned}\therefore \Delta t &= \sqrt{1 - \left(\frac{0.9c}{c}\right)^2} \times 6 \times 10^{-6} \\ &= \sqrt{0.19} \times 6 \times 10^{-6} \\ &= 2.62 \times 10^{-6} \text{ Sec}\end{aligned}$$

---

Problem (4) : Airplane moves with respect to the Earth's frame reference by a velocity  $600 \text{ m/Sec}$  , its original length equals  $50 \text{ m}$  . what is the decrease in length , which seems to be less with respect to an observer exist on the inertial Earth's surface frame .

Solution

$$v = 600 \text{ m/Sec} , c = 3 \times 10^8 \text{ m/Sec} , L = 50 \text{ m}$$

$$L' = L \sqrt{1 - \left(\frac{v}{c}\right)^2} = 50 \sqrt{1 - \left(\frac{600}{3 \times 10^8}\right)^2} = 50 \sqrt{1 - 4 \times 10^{-12}} \quad \therefore \Delta L \approx 10^{-10} \text{ m}$$

---

Problem (5) : **A particle has a mass of 5 Kgm , How much its mass when it moves by a velocity  $0.6 c$  . ?**

solution

$$m = 5 \text{ Kg.} , v = 0.6c$$

$$\therefore m = \frac{m_0}{\sqrt{1 - \left(\frac{v}{c}\right)^2}} = \frac{5}{\sqrt{1 - (0.6)^2}} = \frac{5}{\sqrt{0.64}} = \frac{50}{8} = 6.25 \text{ Kg.}$$

---

Problem (6) : **Particle has a mass 100 Kg, it moves by a velocity  $0.8 c$ . How much its resident mass**

Solution

$$m = 100 \text{ Kg.} , v = 0.8c$$

:

$$\therefore m = \frac{m_0}{\sqrt{1 - \left(\frac{v}{c}\right)^2}} \Rightarrow \therefore m_0 = m \sqrt{1 - \left(\frac{v}{c}\right)^2} \Rightarrow \therefore m_0 = 100 \sqrt{1 - (0.8)^2} \\ = 0.6 \text{ Kg.} = 100 \times 0.6$$

### **Problem (7)**

#### Time Dilation (“Moving Clocks Run Slow”)

- At what speed does a clock move if it runs at a rate which is one-half the rate of a clock at rest?

#### Solution

We assume that the clock is at rest in  $S'$ . As observed by stationary observers in  $S$ , the clock moves in the positive  $x$ -direction with speed  $v$ . Text Eq. (1.30):

$$t = \gamma \left( t' + \frac{vx'}{c^2} \right) \quad (1)$$

relates the time  $t$  measured in  $S$  with the time  $t'$  measured in  $S'$  where

$$\gamma = \frac{1}{\sqrt{1 - \beta^2}} \quad (2)$$

and

$$\beta = v/c \quad (3)$$

Let  $\Delta t'$  be a time interval measured by an observer at rest in  $S'$ . ( $\Delta t'$  is a proper time.  $\Delta t'$  is measured when  $\Delta x' = 0$ .)

Let  $\Delta t$  be the time interval measured by observers at rest in  $S$ .

Then

$$\Delta t = \gamma \Delta t' \quad (4)$$

and therefore

$$\beta = \sqrt{1 - \left(\frac{\Delta t'}{\Delta t}\right)^2} \quad (5)$$

It follows from Eq. (5) that  $\beta = 0.866$  when  $\Delta t = 2\Delta t'$ .

Eq. (4) indicates that the time interval  $\Delta t$  measured by observers at rest in  $S$  is larger than the time interval  $\Delta t'$  measured by an observer at rest with respect to the clock. That is, “moving clocks run slow”.

It is important to note that Eq. (4) relates clock readings on a single clock in  $S'$  with clock readings on two separate clocks in  $S$ .

”Moving clocks run slow” is illustrated by the Light Pulse Clock. For this clock, a light pulse is directed along the positive  $y'$  axis and reflected back to its starting point. The traversal time is recorded as  $\Delta t'$ . In  $S$ , the clock moves along the positive  $x$  axis with speed  $v$ . A stationary observer records the time the light pulse starts and a second stationary observer, farther to the right along the  $x$  axis, records the time when the light pulse returns to its starting point. This traversal time is recorded as  $\Delta t$ . Because of the sideways motion, the light pulse travels farther in  $S$  than in  $S'$ . Since the speed of light is the same in both frames, it follows that the  $\Delta t$  is larger than  $\Delta t'$ . The moving clock runs slow.

### **Problem (8)**

#### Length Contraction (“Moving Rods Contract”)

- At what speed does a meter stick move if its length is observed to shrink to 0.5 m?

#### Solution

We assume that the meter stick is at rest in  $S'$ . As observed by stationary observers in  $S$ , the meter stick moves in the positive  $x$ -direction with speed  $v$ . Text Eq. (1.25):

$$x' = \gamma(x - vt) \quad (6)$$

relates the position  $x'$  measured in  $S'$  with the position  $x$  measured in  $S$ .

Let  $\Delta x'$  be the length of the meter stick measured by an observer at rest in  $S'$ . ( $\Delta x'$  is the proper length of the meter stick.)

The meter stick is moving with speed  $v$  along the  $x$  axis in  $S$ . To determine its length in  $S$ , the positions of the front and back of the meter stick are observed by two stationary observers in  $S$  at the same time. The length of the meter stick as measured in  $S$  is the distance  $\Delta x$  between the two stationary observers at  $\Delta t = 0$ .

Then

$$\Delta x' = \gamma \Delta x \quad (7)$$

where  $\gamma$  is given by Eq. (2). It follows that

$$\beta = \sqrt{1 - \left(\frac{\Delta x}{\Delta x'}\right)^2} \quad (8)$$

It follows from Eq. (8) that  $\beta = 0.866$  when  $\Delta x = \Delta x'/2$ .

Eq. (7) indicates that the length  $\Delta x$  of an object measured by observers at rest in  $S$  is smaller than the length  $\Delta x'$  measured by an observer at rest with respect to the meter stick. That is, “moving rods contract”.

It is important to note that Eq. (7) compares an actual length measurement in  $S'$  (a proper length) with a length measurement determined at equal times on two separate clocks in  $S$ .

### **Problem (9)**

#### Time Dilation for a Slow Moving Object (“Moving Clocks Run Slow”)

An atomic clock is placed in a jet airplane. The clock measures a time interval of 3600 s when the jet moves with speed 400 m/s.

- How much larger a time interval does an identical clock held by an observer at rest on the ground measure?

#### Solution

We take the  $S$  frame to be attached to the Earth and the  $S'$  frame to be the rest frame of the atomic clock.

It follows from Eq. (2) that

$$\gamma \simeq 1 + \beta^2/2 \quad (9)$$

and from Eq. (4) that

$$\delta t = \Delta t - \Delta t' \simeq \beta^2 \Delta t'/2 \quad (10)$$

It follows that  $\delta t = 3.2$  ns when  $v = 400$  m/s and  $\Delta t' = 3600$  s.

### Problem (10)

#### Muon Decay: Time Dilation (“Moving Clocks Run Slow”)

The muon is an unstable particle that spontaneously decays into an electron and two neutrinos. If the number of muons at  $t = 0$  is  $N_0$ , the number  $N$  at time  $t$  is

$$N = N_0 e^{-t/\tau} \quad (11)$$

where  $\tau = 2.20\mu\text{s}$  is the mean lifetime of the muon. Suppose the muons move at speed  $0.95c$ .

- What is the observed lifetime of the muons?
- How many muons remain after traveling a distance of 3.0 km?

#### Solution

We take the  $S$  frame to be attached to the Earth and the  $S'$  frame to be the rest frame of the muon.

It follows from Eq. (4) that  $\Delta t = 7.046\mu\text{s}$  when  $\Delta t' = 2.2\mu\text{s}$  and  $\beta = 0.95$ .

A muon at this speed travels 3.0 km in  $10.53\mu\text{s}$ . After travelling this distance,  $N$  muons remain from an initial population of  $N_0$  muons where

$$N = N_0 e^{-t/\tau} = N_0 e^{-10.53/7.046} = 0.225N_0 \quad (12)$$

### Problem (11)

#### Length Contraction and Rotation

A rod of length  $L_0$  moves with speed  $v$  along the horizontal direction. The rod makes an angle  $\theta_0$  with respect to the  $x'$  axis.

- Determine the length of the rod as measured by a stationary observer.
- Determine the angle  $\theta$  the rod makes with the  $x$  axis.

#### Solution

We take the  $S'$  frame to be the rest frame of the rod.

A rod of length  $L_0$  in  $S'$  makes an angle  $\theta_0$  with the  $x'$  axis. Its projected lengths  $\Delta x'$  and  $\Delta y'$  are

$$\Delta x' = L_0 \cos \theta_0 \quad (13)$$

$$\Delta y' = L_0 \sin \theta_0 \quad (14)$$

In a frame  $S$  in which the rod moves at speed  $v$  along the  $x$  axis, the projected lengths  $\Delta x$  and  $\Delta y$  are given by Eq. (7) and

$$\Delta y' = \Delta y \quad (15)$$

which equation follows from text Eq. (1.26):

$$y' = y \quad (16)$$

The length  $L$  of the rod as measured by a stationary observer in  $S$  is

$$L = \sqrt{(\Delta x)^2 + (\Delta y)^2} = L_0 (1 - \beta^2 \cos^2 \theta_0)^{1/2}. \quad (17)$$

The rod makes an angle  $\theta$  with the  $x$  axis in  $S$  where

$$\tan \theta = \Delta y / \Delta x = \gamma \tan \theta_0. \quad (18)$$

The rod in  $S$  appears contracted and rotated. See also text Fig. (1.14) on page 19 of the text.

### **Problem (12)**

#### Relativistic Doppler Shift

- How fast and in what direction must galaxy  $A$  be moving if an absorption line found at wavelength 550 nm (green) for a stationary galaxy is shifted to 450 nm (blue) (a "blue-shift") for galaxy  $A$ ?
- How fast and in what direction is galaxy  $B$  moving if it shows the same line shifted to 700 nm (red) (a "red shift")?

#### Solution

Galaxy  $A$  is approaching since an absorption line with wavelength 550 nm for a stationary galaxy is shifted to 450 nm. To find the speed  $v$  at which  $A$  is approaching, we use text Eq. (1.13):

$$f_{obs} = \sqrt{\frac{1 + \beta}{1 - \beta}} f_{source} \quad (19)$$

and  $\lambda = c/f$  to write

$$\lambda_{obs} = \sqrt{\frac{1 - \beta}{1 + \beta}} \lambda_{source} \quad (20)$$



from which

$$\beta = \frac{\lambda_{source}^2 - \lambda_{obs}^2}{\lambda_{source}^2 + \lambda_{obs}^2} \quad (21)$$

It follows that  $\beta = 0.198$  when  $\lambda_{source} = 550$  nm and  $\lambda_{obs} = 450$  nm.

Galaxy  $B$  is receding since the same absorption line is shifted to 700 nm. Proceeding as above,

$$\beta = \frac{\lambda_{obs}^2 - \lambda_{source}^2}{\lambda_{obs}^2 + \lambda_{source}^2} \quad (22)$$

It follows that  $\beta = 0.237$  when  $\lambda_{source} = 550$  nm and  $\lambda_{obs} = 700$  nm.

### **Problem (13)**

#### Lorentz Velocity Transformation

Two spaceships approach each other, each moving with the same speed as measured by a stationary observer on the Earth. Their relative speed is  $0.70c$ ,

- Determine the velocities of each spaceship as measured by the stationary observer on Earth.

#### Solution

Text Eq. (1.32) gives the Lorentz velocity transformation:

$$u'_x = \frac{u_x - v}{1 - u_x v / c^2} \quad (23)$$

where  $u_x$  is the velocity of an object measured in the  $S$  frame,  $u'_x$  is the velocity of the object measured in the  $S'$  frame and  $v$  is the velocity of the  $S'$  frame along the  $x$  axis of  $S$ .

We take the  $S$  frame to be attached to the Earth and the  $S'$  frame to be attached to the spaceship moving to the right with velocity  $v$ . The other spaceship has velocity  $u_x = -v$  in  $S$  and velocity  $u'_x = -0.70c$  in  $S'$ .

It follows from Eq. (23) that

$$0.70 = \frac{2\beta}{1 + \beta^2} \quad (24)$$

solving which yields  $\beta = 0.41$ . As measured by the stationary observer on Earth, the spaceships are moving with velocities  $\pm 0.41c$ .

### **Problem (14)**

#### Lorentz Velocity Transformation

A stationary observer on Earth observes spaceships A and B moving in the same direction toward the Earth. Spaceship A has speed  $0.5c$  and spaceship B has speed  $0.80c$ .

- Determine the velocity of spaceship A as measured by an observer at rest in spaceship B.

Solution

We take the  $S$  frame to be attached to the Earth and the  $S'$  frame to be attached to spaceship B moving with velocity  $v = -0.8c$  along the  $x$  axis. Spaceship A has velocity  $u_x = -0.50c$  in  $S$ .

It follows from Eq. (23) that spaceship A has velocity  $u'_x = 0.50c$  in  $S'$ . Spaceship A moves with velocity  $0.5c$  as measured by an observer at rest in spaceship B.

**Problem (15)**Speed of Light in a Moving Medium

The motion of a medium such as water influences the speed of light. This effect was first observed by Fizeau in 1851.

Consider a light beam passing through a horizontal column of water moving with velocity  $v$ .

- Determine the speed  $u$  of the light measured in the lab frame when the beam travels in the same direction as the flow of the water.
- Determine an approximation to this expression valid when  $v$  is small.

Solution

We assume that the light beam and the tube carrying water are oriented along the positive  $x$ -direction of the lab frame. The speed of light  $u$  in the lab frame is related to the speed of light  $u'$  in a frame moving with the water by text Eq. (1.34):

$$u = \frac{u' + v}{1 + u'v/c^2} \quad (25)$$

where  $v$  is the speed of the water in the lab frame.

Now  $u' = c/n$ , where  $n$  is the index of refraction of water, so

$$u = \frac{c}{n} \left( \frac{1 + n\beta}{1 + \beta/n} \right) \quad (26)$$

Using

$$(1 + \beta/n)^{-1} \simeq (1 - \beta/n) \quad (27)$$

it follows that

$$u \simeq \frac{c}{n} + v \left( 1 - \frac{1}{n^2} \right). \quad (28)$$

This equation agrees with Fizeau's experimental result. The equation shows that the Lorentz velocity transformation and not the Galilean velocity is correct for light.

**Problem (16)**Lorentz Velocity Transformations for Two Components

As seen from Earth, two spaceships A and B are approaching along perpendicular directions.

- If A is observed by a stationary Earth observer to have velocity  $u_y = -0.90c$  and B to have velocity  $u_x = +0.90c$ , determine the speed of ship A as measured by the pilot of ship B.

### Solution

----

We take the  $S$  frame to be attached to the Earth and the  $S'$  frame to be attached to spaceship B moving with  $\beta = 0.90$  along the  $x$  axis. Spaceship A has velocity components  $u_x = 0, u_y = -0.90c$  in  $S$ .

Eq. (23) and text Eq. (1.33):

$$u'_y = \frac{u_y}{\gamma(1 - u_x v/c^2)} \quad (29)$$

give the velocity components of spaceship A in  $S'$ , from which

$$u'_x = -v = -0.90c \quad (30)$$

$$u'_y = u_y/\gamma = -0.39c \quad (31)$$

so

$$u' = \sqrt{(u'_x)^2 + (u'_y)^2} = 0.98c. \quad (32)$$

-----

### Problem (17)

#### Lorentz Velocity Transformation

A spaceship moves away from Earth with speed  $v$  and fires a shuttle craft in the forward direction at a speed  $v$  relative to the spaceship. The pilot of the shuttle craft launches a probe in the forward direction at speed  $v$  relative to the shuttle craft.

- Determine the speed of the shuttle craft relative to the Earth.
- Determine the speed of the probe relative to the Earth.

### Solution

We take the  $S$  frame to be attached to the Earth and the  $S'$  frame to be attached to the spaceship moving with speed  $v$  along the  $x$  axis. The shuttle craft has speed  $u'_x = v$  in  $S'$ . Text Eq. (1.34):

$$u_x = \frac{u'_x + v}{1 + u'_x v/c^2} \quad (112)$$

gives its speed  $u_x$  in  $S$  as

$$u_x = \frac{2v}{1 + \beta^2}. \quad (113)$$

We now take the  $S'$  frame to be attached to the shuttle craft moving with speed

$$\tilde{v} = \frac{2v}{1 + \beta^2} \quad (114)$$

along the  $x$  axis. The probe has speed  $u'_x = v$  in  $S'$ . Its speed  $u_x$  in  $S$  is given by Eq. (112) with  $v$  replaced by  $\tilde{v}$  from which

$$u_x = \left( \frac{3 + \beta^2}{1 + 3\beta^2} \right) v \quad (115)$$

It follows from Eq. (115) that  $u_x \rightarrow 3v$  when  $\beta \ll 1$  and  $u_x \rightarrow c$  when  $\beta \rightarrow 1$ .

## QUESTION BANK

### MULTIPLE CHOICE QUESTIONS

- (1) According to the special theory of relativity, something that happens at a particular point in space at a particular instant of time is called \_\_\_\_\_.  
 (a) Event      (b) Phenomenon      (c) Incident      (d) Happening
- (2) According to the special theory of relativity, a person or equipment meant to observe and take measurement about the event is called \_\_\_\_\_.  
 (a) supervisor      (b) observer      (c) examiner      (d) invigilator
- (3) A frame of reference is specified by a :  
 (a) observer      (b) decimal system      (c) coordinate system      (d) metric system
- (4) The frame of reference in which the law of inertia is satisfied is called \_\_\_\_\_ frame of reference.  
 (a) Einstein's      (b) Newton's      (c) non-inertial      (d) inertial
- (5) The frame of reference in which the law of inertia is not satisfied is called \_\_\_\_\_ frame of reference.  
 (a) Einstein's      (b) Newton's      (c) non-inertial      (d) inertial
- (6) A car moving with a constant velocity represents \_\_\_\_\_ frame of reference.  
 (a) Einstein's      (b) inertial      (c) non-inertial      (d) Newton's
- (7) The special theory of relativity deals with the motion of objects in \_\_\_\_\_ frame of references.  
 (a) inertial      (b) Newton's      (c) Einstein's      (d) non-inertial
- (8) According to the special theory of relativity the speed of light is \_\_\_\_\_.  
 (a) zero      (b) constant      (c) infinite      (d) not predictable

(9) Any object can be located or any event can be described using a coordinate system. This coordinate system is called \_\_\_\_\_.

- (a) coordinate frame (b) reference system  
(c) reference frame (d) coordinate frame

(10) Which one of the following is NOT a property of Ether?

- (a) zero density (b) perfectly transparent  
(c) high elasticity (d) zero elasticity

(11) The Special theory of relativity deals with problems of mechanics in which one frame moves with \_\_\_\_\_ velocity relative to the other frame

- (a) greater (b) infinite (c) constant (d) lesser

(12) The Michelson-Morley experiment was performed to verify the presence of \_\_\_\_\_ .

- (a) matter (b) ether (c) aliens (d) flying objects

(13) The Michelson-Morley experiment established the fact that the ether

- (a) does not exist (b) exists (c) is breakable (d) is unbreakable

(14) The Michelson-Morley experiment established the fact that the velocity of light is

- (a) constant and dependent of the frame of reference  
(b) constant and independent of the frame of reference  
(c) variable and independent of the frame of reference  
(d) variable and dependent of the frame of reference

(15) The instrument that was used in Michelson-Morley experiment was

- (a) Jamin refractometer (b) Rayleigh refractometer  
(c) Michelson's interferometer (d) Fabry-Perot interferometer

(16) The equations representing an event in one frame of reference can be transformed to other frame of reference using \_\_\_\_\_ equations.

- (a) cosmological (b) continuity (c) canonical (d) transformation

(17) In Galilean transformation acceleration is \_\_\_\_\_.

- (a) variant (b) very high (c) invariant (d) infinite

(18) Lorentz transformations are converted into Galilean transformation for \_\_\_\_\_ particle.

- (a) large mass (b) Small velocity (c) large velocity (d) small mass

(19) According to the special theory of relativity a moving clock always go :

- (a) slow (b) down (c) up (d) fast

(20) The energy momentum relation in special theory of relativity is given by

(a)  $E = \sqrt{m_0^2 c^4 + c^2 p^2}$  (b)  $E = \sqrt{m_0^4 c^4 + c^4 p^4}$

(c)  $E = \sqrt{m_0^2 c^4 - c^2 p^2}$  (d)  $E = \sqrt{m_0 c^2 + c^2 p^2}$

**SHORT QUESTIONS (TWO MARKS EACH)**

1. Define : Event and Observer
2. Define : Inertial Frame of reference and Non-Inertial frame of reference.
3. Define : Frame of Reference and Ether.
4. Enlist the properties of ether.
5. Write a short note on luminiferous ether.
6. State the two postulates of Special Theory of Relativity.
7. Discuss the major conclusions of Michelson-Morley experiment.
8. Write the equations for the Galilean transformation equations.
9. Write the equations for the Lorentz transformation equations.
10. With the help of an example explain why Lorentz Fitzgerald length contraction is not applicable to the objects which are not moving with relativistic speed.
11. Derive the energy-momentum relationship for a particle moving at relativistic speed.

**LONG QUESTIONS**

1. Define frame of reference and discuss the inertial and non inertial frames of references with the help of necessary diagrams.
2. Discuss the Galilean transformation equations in detail.
3. Explain the concept of luminiferous ether and state the postulates of theory of relativity.
4. What is luminiferous ether? Discuss the Michelson-Morley experiment for the search of ether, derive the necessary equations and state its major conclusions.
5. With the help of necessary diagram discuss the Michelson- Morley experiment and enlist its major outcomes.
6. Explain the failure of Galilean transformation equations and derive the Lorentz transformation equation with the help of necessary diagrams and equations.
7. Discuss the phenomenon of Lorentz-Fitzerald length contraction along with an example.
8. Write a detailed note on Time Dilation.
9. Explain why a moving clock (at a relativistic speed) appears to go slow.
10. Derive the expression for the kinetic energy of a particle moving at relativistic speed and hence establish the relationship showing the equivalence of its mass and energy.
11. Obtain the energy-momentum relationship for a particle moving at relativistic speed.



## **Chapter (3)**

# **Relativity (II)**

## **Relativistic Kinematics**

## Chapter (3) Relativistic Kinematic

### Relativistic mass (changing mass with velocity)

One of the important outcomes of special relativity is the effect of velocity on mass of the moving object. From Newtonian mechanics, the velocity of any object has a mass ( $m$ ), increases under a continuous affecting force according to the following equation :

$$v_t = v_0 + a t = v_0 + \frac{F}{m} t \quad (1)$$

$v_0$  = velocity at any moment ( $t$ )

$a$  = acceleration of the object  $a = \frac{F}{m}$

This tell us that ,  $v_0$  increased to infinity after an infinite time . This result not true , if we consider from the postulate of the special relativity that there is a maximum velocity , it is the light speed. To solve this problem, consider the mass of the object increases by increasing the velocity of the object according the following equation :

$$m = \gamma m_0 \quad (2)$$

$m_0$  = Rest mass of the object

$m$  = Mass of the object when it moves by a velocity ( $v$ )

Mass of the object given by :

$$m = \frac{m_0}{\sqrt{1 - \left(\frac{v}{c}\right)^2}} \quad (3)$$

This equation indicates as the velocity of the object close to the light speed , the mass of the object highly increases until it becomes infinite value, if  $v$  close to  $C$ .



The mass becomes infinity , it need big force to moves, and this force not exist in nature.

Note : According to Newtonian mechanics, the mass of the object is constant, and it doesn't depend on the its velocity. This not agree with special relatively, because the mass increases by increasing its velocity,

$$m = m_0 / (1 - v^2 / c^2)^{\frac{1}{2}}$$

$m_0$  = Rest mass of the body with respect to the velocity observer

$m$  = Effective mass of the moving body with velocity ( $v$ )

The above relativistic mas equation tell us , in the direction of the motion, the mass of a body in any moving inertial reference frame increases with increasing its velocity and reach infinity when ( $v$ ) close to( $C$ ) . But at very low velocity ( $v$ ),compared to ( $C$ ), the term [  $\beta = v^2/c^2$  ] can be neglected, in this case the mass of the body still as it is, as it was described in classical mechanics.

## Relativity II: Mass, Energy and Momentum

### Energy and Momentum

We require that all the “Laws” of Physics be the same in all inertial reference frames. We require further that when  $v \ll c$ , we recover the familiar Newtonian forms of the “Laws.” The latter requirement is called a *Correspondence Principle*. What are those “Laws”?

#### 1. Conservation of Momentum

We define a *relativistic momentum* so that the two conditions above are satisfied.

$$\vec{p} = \gamma m \vec{u}$$

This  $m$  is the *rest mass*—the mass measured by an observer at rest with respect to the object. This quantity should be the same in all inertial reference frames. With this definition,  $\vec{p}_{initial} = \vec{p}_{final}$  in all inertial reference frames.

#### 2. Relativistic Energy

##### a. Work-energy theorem (one dimensional)

The work done by a force on an object changes its kinetic energy, thus

$$\Delta K = W_{12} = \int_{x_1}^{x_2} F dx.$$

$$\Delta K = \int_{x_1}^{x_2} \frac{dp}{dt} dx$$

$$\Delta K = \int_{t_1}^{t_2} \frac{dp}{dt} \frac{dx}{dt} dt$$

$$\Delta K = \int u dp$$

Integrate by parts.

$$\Delta K = up \Big|_{u_1}^{u_2} - \int_{u_1}^{u_2} p du$$

$$\Delta K = up \Big|_{u_1}^{u_2} - \int_{u_1}^{u_2} \frac{mu}{\sqrt{1 - \frac{u^2}{c^2}}} du$$

Recall that  $u du = \frac{du^2}{2}$ .

$$\Delta K = up \Big|_{u_1}^{u_2} - \frac{m}{2} \int \frac{du^2}{\sqrt{1 - \frac{u^2}{c^2}}}$$

Look up the form  $\int \frac{dx}{\sqrt{a+bx}}$  in a math tables book.

$$\Delta K = up \Big|_{u_1}^{u_2} - \frac{m}{2} \left[ \frac{2\sqrt{1 - \frac{u^2}{c^2}}}{-\frac{1}{c^2}} \right]_{u_1}^{u_2}$$

$$\Delta K = \left[ \frac{mu^2}{\sqrt{1 - \frac{u^2}{c^2}}} + mc^2 \sqrt{1 - \frac{u^2}{c^2}} \right]_{u_1}^{u_2}$$

$$\Delta K = \left[ \frac{mu^2 + mc^2 - mu^2}{\sqrt{1 - \frac{u^2}{c^2}}} \right]_{u_1}^{u_2} = \Delta \left[ \frac{mc^2}{\sqrt{1 - \frac{u^2}{c^2}}} \right]$$

Now, if we started from rest, then  $u_1 = 0$  and  $u_2 = u$  and  $\Delta K = \frac{mc^2}{\sqrt{1-\frac{u^2}{c^2}}} - mc^2$ . Therefore, we

define the *relativistic kinetic energy* to be

$$K = \frac{mc^2}{\sqrt{1-\frac{u^2}{c^2}}} - mc^2.$$

The quantity  $mc^2$  is called the *rest energy*, because it's independent of  $u$ . The *total relativistic energy* is  $E = K + mc^2 + V$ , where  $V$  is the potential energy, if any. If  $V = 0$ , then

$$E = K + mc^2 = \gamma mc^2.$$

b. Energy-momentum relation

Take a look at the quantity ( $V = 0$ )

$$E^2 - m^2 c^4 = \frac{m^2 c^4}{1-\frac{u^2}{c^2}} - m^2 c^4 = \frac{m^2 c^2 u^2}{1-\frac{u^2}{c^2}} = c^2 \left( \frac{m^2 u^2}{1-\frac{u^2}{c^2}} \right).$$

$$E^2 - m^2 c^4 = c^2 p^2$$

$$E^2 = c^2 p^2 + m^2 c^4$$

For photons,  $m = 0$  and  $E = pc$ .

c. Units of mass-energy

It is convenient to express energy in units of electron-volts (eV). An *electron-volt* is the energy gained by an electron upon being accelerated through a one Volt potential difference. Thus  $1 \text{ eV} = 1.60 \times 10^{-19} \text{ Joules}$ . The rest energy of an electron is

$$mc^2 = 9.11 \times 10^{-31} \text{ kg} (3 \times 10^8 \text{ m/sec})^2 = 8.20 \times 10^{-14} \text{ J} = 0.511 \times 10^6 \text{ eV} = 0.511 \text{ MeV}.$$

Often, mass is expressed in terms of  $\text{MeV}/c^2$  so that the electron mass is  $0.511 \text{ MeV}/c^2$ .

Sometimes, the  $c^2$  is dropped, but it's understood to still be there. Similarly, momentum is expressed in terms of  $\text{MeV}/c$ , since  $pc = \text{units of MeV}$ .

### 3. Relativistic Mechanics

#### a. Force

We want the “Laws” of Mechanics to be invariant under the Lorentz Transformation. Also, we want to recover the classical result when  $u \ll c$ . So, we define the *relativistic force* component

to be  $F_x = \frac{dp_x}{dt}$ , where  $p_x = \frac{mu_x}{\sqrt{1 - \frac{u^2}{c^2}}}$ .

Let's say the motion and force are entirely along the x-direction.

$$F = \frac{d}{dt} \left[ \frac{mu}{\sqrt{1 - \frac{u^2}{c^2}}} \right] = \frac{m}{\sqrt{1 - \frac{u^2}{c^2}}} \frac{du}{dt} + mu \frac{d}{dt} \left[ \frac{1}{\sqrt{1 - \frac{u^2}{c^2}}} \right]$$

$$F = \frac{m}{\sqrt{1 - \frac{u^2}{c^2}}} \frac{du}{dt} + mu \left( -\frac{1}{2} \right) \left( 1 - \frac{u^2}{c^2} \right)^{-3/2} \left( -\frac{2u}{c^2} \right) \frac{du}{dt}$$

$$F = m \frac{du}{dt} \left[ \left( 1 - \frac{u^2}{c^2} \right)^{-1/2} + \frac{u^2}{c^2} \left( 1 - \frac{u^2}{c^2} \right)^{-3/2} \right]$$

$$F = m \left( \frac{1}{1 - \frac{u^2}{c^2}} \right)^{3/2} \frac{du}{dt}$$

Solve for the acceleration.

$$\frac{du}{dt} = \frac{F}{m} \left( 1 - \frac{u^2}{c^2} \right)^{3/2}$$

The result is, that as  $u \rightarrow c$ ,  $\frac{du}{dt} \rightarrow 0$ , no matter how large the applied force. At the other extreme, when  $u \ll c$ ,  $\frac{du}{dt} = \frac{F}{m}$ .

### b. Collisions—conservation of momentum

Consider the collision of two billiard balls. They have equal masses,  $m$ . Let's say that one ball is initially at rest while the second ball has momentum  $p_o$  and energy  $E_o$  before the collision. After the collision, both balls have the same energy,  $E$ , and mass,  $m$ . It's an elastic collision. Momentum and energy are conserved.

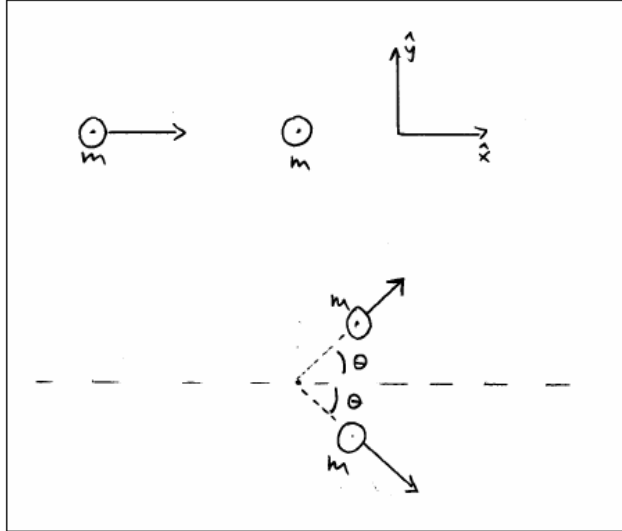

In the x direction,  $p_o = 2p \cos \theta$ . Substitute for  $p_o$  and  $p$  using  $E^2 = p^2 c^2 + m^2 c^4$ .

$$\frac{1}{c} \sqrt{E_o^2 - m^2 c^4} = \frac{2}{c} \sqrt{E^2 - m^2 c^4} \cos \theta$$

Conservation of energy allows us to eliminate  $E$ , since it was given that  $E_o + mc^2 = 2E$ . Keep in mind that  $E_o$  is the relativistic total energy of the second ball, while  $mc^2$  is the rest energy of the first (target) ball. At the same time, we solve for  $\cos \theta$ , the cosine of the scattering angle.

$$\cos \theta = \frac{\sqrt{E_o^2 - m^2 c^4}}{\sqrt{(E_o + mc^2)^2 - 4m^2 c^4}} = \sqrt{\frac{(E_o + mc^2)(E_o - mc^2)}{(E_o + 3mc^2)(E_o - mc^2)}}$$

$$\cos \theta = \sqrt{\frac{E_o + mc^2}{E_o + 3mc^2}}$$

In the classical limit,  $E_o \approx mc^2$  and therefore

$$\cos \theta \approx \sqrt{\frac{2mc^2}{4mc^2}} = \sqrt{\frac{1}{2}} \Rightarrow \theta = 45^\circ. \text{ But, as } E_o \gg$$

$$mc^2, \cos \theta \rightarrow 1 \Rightarrow \theta \rightarrow 0^\circ!$$

### c. Decay of a high-energy particle

An unidentified high-energy particle is observed to decay into two pions ( $\pi$  mesons), as shown.

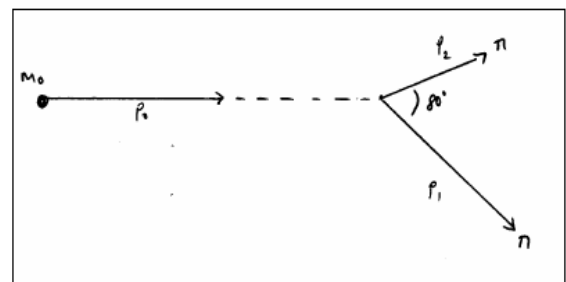

Knowing the momenta and masses of the decay products, we determine the mass of the incident particle, hoping to identify it.

$$p_1 = 910 \frac{\text{MeV}}{c}, \quad p_2 = 323 \frac{\text{MeV}}{c}, \quad m_1 c^2 = m_2 c^2 = m c^2 = 139.6 \text{ MeV}.$$

The energy and momenta are conserved. The total energy is

$$E_o = E_1 + E_2 = \sqrt{p_1^2 c^2 + m^2 c^4} + \sqrt{p_2^2 c^2 + m^2 c^4}$$

$$E_o = 921 \text{ MeV} + 352 \text{ MeV} = 1273 \text{ MeV}$$

The quickest way to obtain the magnitude of the incident momentum is to use the law of cosines:

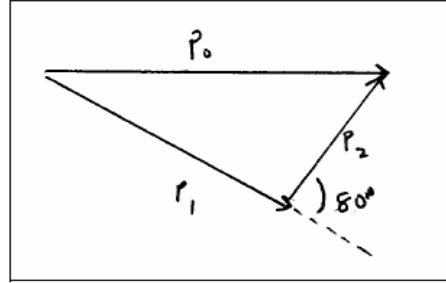

$$p_o^2 c^2 = p_1^2 c^2 + p_2^2 c^2 - 2 p_1 p_2 c^2 \cos \theta = 1034229 \text{ MeV}^2$$

$$p_o c = 1017 \text{ MeV}$$

Now that we have the total energy and the kinetic energy, the mass is obtained from

$$E_o^2 = p_o^2 c^2 + m_o^2 c^4$$

$$m_o c^2 = \sqrt{E_o^2 - p_o^2 c^2} = 765 \text{ MeV}$$

Evidently, the incident particle was a  $\rho$  meson. What was its speed before it decayed? Well,

the total energy is also  $E_o^2 = \frac{m_o^2 c^4}{1 - \frac{u^2}{c^2}}$ , so solve that for  $u$ .

$$\frac{u}{c} = 1 - \sqrt{\frac{m_o^2 c^4}{E_o^2}} = 0.8$$

#### d. Mass-energy equivalence

When we speak of the total energy being conserved that includes the total rest energy. For instance, consider the decay of a neutron that is initially at rest.

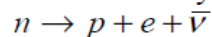

The neutron decays into a proton, an electron and an anti-neutrino. The three product particles are observed to have total kinetic energy of  $K = 0.781 \text{ MeV}$ . The initial energy is just the rest energy of the neutron,  $E_i = 939.57 \text{ MeV}$ . The total final energy is

$$E_f = m_p c^2 + m_e c^2 + K = 938.28 \text{ MeV} + 0.511 \text{ MeV} + 0.781 \text{ MeV} = 939.57 \text{ MeV}$$

Notes: i) The rest energy of the anti-neutrino is too small to bother with.

ii) Keep in mind the rounding of numbers and significant digits when substituting numerical values into the formulae.

iii) Notice that  $m_n \neq m_p + m_e$ . A portion of the neutron's rest energy has been converted into kinetic energy.

### Solved Problems

Problem (1) : If a resident particle splits into two moving parts in opposite direction , their masses and velocities respectively are 3 Kg and 5.33 Kg and 0.6 c and 0.8 c. How much the mass of the original particle ?

#### Solution

$$m_{01} = 5.33 \text{ Kg} , m_{02} = 3 \text{ Kg} , v_1 = 0.8c , v_2 = 0.6c$$

**Initial Energy = Final Energy**

$$\begin{aligned} \therefore mc^2 &= \frac{m_{01} c^2}{\sqrt{1 - \left(\frac{0.8c}{c}\right)^2}} + \frac{m_{02} c^2}{\sqrt{1 - \left(\frac{0.6c}{c}\right)^2}} \\ m_0 &= \frac{5.33}{\sqrt{1 - 0.64}} + \frac{3}{\sqrt{1 - 0.36}} = \frac{5.33}{0.6} + \frac{3}{0.8} = 12.63 \text{ Kg} \end{aligned}$$

---

Problem (2) : Calculate the momentum of electron with kinetic energy equals one Million electron volt .

#### Solution

$$E = \sqrt{m_0^2 c^4 + P^2 c^2}$$

$$E^2 = m_0^2 c^4 + P^2 c^2$$

Energy = Kinetic Energy + Potential = Total Energy

$$E = m_0 c^2 + K$$

$$\therefore (m_0 c^2 + 1\text{MeV})^2 = m_0^2 c^4 + P^2 c^2$$

$$(0.511 + 1)^2 = (0.511)^2 + P^2 c^2$$

$$1 + 2(0.511) + (0.511)^2 = (0.511)^2 + P^2 c^2$$

$$1 + 1.022 = P^2 c^2$$

$$P = \sqrt{\frac{2.022}{c^2}}$$

---



Problem (3) : An electron was accelerated from its rest position with velocity  $0.5c$  . Calculate the change in its kinetic energy.

**Solution**

$$E_0 = m_0 c^2 = 0.511 \text{ MeV}$$

**At the speed  $0.5 c$  :**

$$E = mc^2 = \frac{m_0 c^2}{\sqrt{1 - (v/c)^2}} = \frac{0.511 \text{ MeV}}{\sqrt{1 - 0.25}} = \frac{0.511}{\sqrt{0.75}}$$

$$E = 0.59 \text{ MeV}$$

$$K = 0.59 - 0.511 = 0.079 \text{ MeV}$$

Problem (4) : Calculate the Kinetic energy of the electron which its momentum equals  $(2/c)$  Mev

**Solution**

$$E^2 = (m_0 c^2)^2 + (Pc)^2$$

$$(K + m_0 c^2)^2 = (m_0 c^2)^2 + (Pc)^2$$

$$(K + 0.511)^2 = \left( \frac{2 \text{ MeV}}{c} \times c \right)^2 + (0.511)^2$$

$$K = 1.55 \text{ MeV}$$

Problem (5) : Calculate the velocity of an electron its kinetic energy  $2 \text{ MeV}$

**Solution**

$$K = (m - m_0) c^2$$

$$K = \frac{m_0 c^2}{\sqrt{1 - (v/c)^2}} - m_0 c^2$$

$$2 \text{ MeV} = \frac{0.511 \text{ MeV}}{\gamma} - 0.511 \text{ MeV}$$

$$\gamma = \frac{0.511}{2.511} = 0.203$$

$$\gamma = \frac{v}{c} \Rightarrow v = \gamma c$$

$$v = 0.89 c$$

Problem (6) :

- a– Calculate the mass and the velocity, if its kinetic energy equals 1.5 MeV  
 b– What is the energy by the unit of electron volt which required for the electron to transfer from its rest position to a velocity equals (0.9 C)

### Solution

$$K = (m - m_0) c^2 \quad (1)$$

$$m = \frac{m_0}{\sqrt{1 - (v/c)^2}} \quad (2)$$

$$\text{From Eq. (1) : } m = m_0 + K/c^2$$

$$\text{The electron mass : } m_0 = 9.1 \times 10^{-31} \text{ Kg}$$

$$\text{Light speed : } c = 3 \times 10^8 \text{ m/Sec}$$

$$K = 1.5 \text{ MeV} = 1.5 \times 10^6 \text{ eV} = 1.5 \times 10^6 (1.6 \times 10^{-19})$$

$$K = 1.5 \times 1.6 \times 10^{-13} \text{ Joule}$$

$$m = (9.11 \times 10^{-31}) + \frac{1.5 \times 1.6 \times 10^{-13}}{(9 \times 10^{16})}$$

$$m = (9.11 \times 10^{-31}) + (26.7 \times 10^{-31})$$

$$m = 35.8 \times 10^{-31} \text{ Kg}$$

The value of moving mass equals four time it's a rest mass

The velocity of the electron from Eq (2)

$$m = \frac{m_0}{\sqrt{1 - (v/c)^2}}$$

Squaring the both side of this equation :

$$1 - (v/c)^2 = (m_0/m)^2$$

$$\frac{v^2}{c^2} = 1 - \left(\frac{m_0}{m}\right)^2 \Rightarrow \frac{v}{c} = \sqrt{1 - \left(\frac{m_0}{m}\right)^2}$$

$$v = c \sqrt{1 - \left(\frac{m_0}{m}\right)^2} = 3 \times 10^8 \times \sqrt{1 - \left(\frac{9.11}{35.8}\right)^2}$$

$$v = 3 \times 10^8 \times \sqrt{1 - 0.065} = 3 \times 10^8 \times \sqrt{0.935}$$

$$v = 3 \times 10^8 \times 0.968 = 2.9 \times 10^8 \text{ m/Sec}$$

(b) : Required energy for transferring the electron from rest to 0.9 c si :

$$K = (m - m_0) c^2$$

$$m = \frac{m_0}{\sqrt{1 - (v/c)^2}}$$

$$K = \left( \frac{m_0}{\sqrt{1 - (v/c)^2}} - m_0 \right) c^2$$

$$K = \left( \frac{1}{\sqrt{1 - (v/c)^2}} - 1 \right) m_0 c^2$$

$$v = 0.9c \quad \therefore (v/c)^2 = 0.81$$

$$\frac{1}{\sqrt{1 - (v/c)^2}} = \frac{1}{\sqrt{1 - 0.81}} = \frac{1}{\sqrt{0.19}} = 2.29$$

$$K = (2.29 - 1) m_0 c^2 = 1.29 m_0 c^2$$

$$K = 1.29 \times 9.11 \times 10^{-31} \times 9 \times 10^{16}$$

$$K = 10.6 \times 10^{-14} \text{ Joule} = \frac{10.6 \times 10^{-14}}{1.6 \times 10^{-19}} = 6.63 \times 10^5 \text{ eV}$$

### Problem (7)

#### Relativistic Form of Newton's Second Law

Consider the relativistic form of Newton's Second Law.

- Show that when  $\mathbf{F}$  is parallel to  $\mathbf{v}$

$$F = m \left(1 - \frac{v^2}{c^2}\right)^{-3/2} \frac{dv}{dt} \quad (33)$$

where  $m$  is the mass of the object and  $v$  is its speed.

### Solution

The force  $\mathbf{F}$  on a particle with rest mass  $m$  is the rate of change its momentum  $\mathbf{p}$  as given by text Eq. (1.36):

$$\mathbf{F} = \frac{d\mathbf{p}}{dt} \quad (34)$$

where as given by text Eq. (1.35):

$$\mathbf{p} = \gamma m \mathbf{v} \quad (35)$$

where

$$\gamma = \frac{1}{\sqrt{1 - v^2/c^2}} \quad (36)$$

where  $\mathbf{v}$  is the velocity of the particle. Eq. (34) with  $\mathbf{p}$  given by Eq. (35) is the relativistic generalization of Newton's Second Law.

Now

$$\mathbf{v} = v \mathbf{u}_t \quad (37)$$

where  $\mathbf{u}_t$  is a unit vector along the tangent of the particle's trajectory, and the acceleration  $\mathbf{a}$  of the particle is

$$\mathbf{a} = \frac{d\mathbf{v}}{dt} = \frac{dv}{dt} \mathbf{u}_t + \frac{v^2}{\rho} \mathbf{u}_n \quad (38)$$

where  $\mathbf{u}_n$  is a unit vector orthogonal to  $\mathbf{u}_t$  directed towards the centre of curvature of the trajectory and  $\rho$  is the radius of curvature of the trajectory, so

$$\frac{d\mathbf{p}}{dt} = \gamma m \left( \gamma^2 \frac{dv}{dt} \mathbf{u}_t + \frac{v^2}{\rho} \mathbf{u}_n \right) \quad (39)$$

When

$$\mathbf{F} = F \mathbf{u}_t \quad (40)$$

that is, when  $\mathbf{F}$  is parallel to  $\mathbf{v}$ , it follows that

$$\rho = \infty \quad (41)$$

That is, the particle moves in a straight line, and

$$a = \tilde{a}/\gamma^3 \quad (42)$$

where

$$a = \frac{dv}{dt} \quad (43)$$

and

$$\tilde{a} = \frac{F}{m} \quad (44)$$

## Problem (8)

### Relativistic Form of Newton's Second Law: Particle in an Electric Field

A charged particle moves along a straight line in a uniform electric field  $\mathbf{E}$  with speed  $v$ .

• If the motion and the electric field are both in the  $x$  direction, show that the magnitude of the acceleration of the charge  $q$  is given by

$$a = \frac{dv}{dt} = \frac{qE}{m} \left(1 - \frac{v^2}{c^2}\right)^{3/2} \quad (45)$$

- Discuss the significance of the dependence of the acceleration on the speed.
- If the particle starts from rest  $x = 0$  at  $t = 0$ , find the speed of the particle and its position after a time  $t$  has elapsed.
- Comment of the limiting values of  $v$  and  $x$  as  $t \rightarrow \infty$ .

### Solution

When a particle of charge  $q$  moves in an electric field  $\mathbf{E}$ , the force  $\mathbf{F}$  on the particle is  $\mathbf{F} = q\mathbf{E}$ . If the particle moves in the direction of  $\mathbf{E}$ , then  $\mathbf{F}$  and  $\mathbf{v}$  are parallel. Accordingly, Eq. (42) holds with  $\tilde{a} = qE/m$ .

It follows from Eq. (42) that  $a \rightarrow 0$  as  $v \rightarrow c$  and also that

$$F \simeq ma \quad \text{when } v \ll c \quad (46)$$

which is the nonrelativistic result.

When  $F$  is constant and the particle starts from rest at  $t = 0$ , its speed  $v(t)$  is found by integrating Eq. (42):

$$\int_0^{v(t)} \frac{dv'}{(1 - v'^2/c^2)^{3/2}} = \tilde{a}t \quad (47)$$

to be

$$v(t) = \frac{\tilde{a}t}{\sqrt{1 + (\tilde{a}t/c)^2}}. \quad (48)$$

It follows that  $v(t) \rightarrow c$  as  $t \rightarrow \infty$  and also that

$$v(t) \simeq \tilde{a}t \quad \text{when } \tilde{a}t \ll c \quad (49)$$

which is the non-relativistic result.

The position  $x(t)$  of the particle is found by integrating  $v = dx/dt$ :

$$x(t) = \int_0^t v(t') dt' = \left( \sqrt{1 + (\tilde{a}t/c)^2} - 1 \right) c^2/\tilde{a}. \quad (50)$$

It follows that  $x \rightarrow ct$  as  $t \rightarrow \infty$  and also that

$$x(t) \simeq \frac{1}{2} \tilde{a} t^2 \quad \text{when } \tilde{a} t \ll c \quad (51)$$

which is the nonrelativistic result.

The position  $x(v)$  is found by integrating  $a(v) = dv/dt = v dv/dx$ :

$$x(v) - x(0) = \int_{x(0)}^v \frac{v' dv'}{a(v')} = (\gamma - 1) c^2 / \tilde{a}. \quad (52)$$

It follows that  $x(v) - x(0) \rightarrow \infty$  as  $v \rightarrow c$  and also that

$$v^2 \simeq 2\tilde{a}[x(v) - x(0)] \quad \text{when } v \ll c \quad (53)$$

which is the nonrelativistic result.

## Problem (9)

### Relativistic Form of Newton's Second Law: Particle in a Magnetic Field

The force  $\mathbf{F}$  on a particle with rest mass  $m$  and charge  $q$  moving with velocity  $\mathbf{v}$  in a magnetic field  $\mathbf{B}$  is

$$\mathbf{F} = q\mathbf{v} \times \mathbf{B}. \quad (54)$$

• If the particle moves in a circular orbit with a fixed speed  $v$  in the presence of a constant magnetic field, use Newton's Second Law to show that the frequency of its orbital motion is

$$f = \frac{qB}{2\pi m} \left(1 - \frac{v^2}{c^2}\right)^{1/2} \quad (55)$$

#### Solution

When a particle moves with constant speed, that is, when

$$\frac{dv}{dt} = 0 \quad (56)$$

it follows from Eqs. (34) and (39) that

$$\tilde{\omega}\rho = \gamma v \quad (57)$$

where

$$\tilde{\omega} = \frac{qB \sin \theta}{m} \quad (58)$$

where  $\theta$  is the angle that  $\mathbf{v}$  makes with  $\mathbf{B}$ . For a proton moving perpendicular to a 1.00 T magnetic field,  $\tilde{\omega} = 95.8$  MHz.

The right side of Eq. (57) is constant. Accordingly, the radius of curvature  $\rho$  of the particle's trajectory changes to accommodate changes in the magnetic field  $\mathbf{B}$ .

When  $\mathbf{B}$  is constant (that is, time-independent and homogeneous), it follows from Eq. (57) that the particle moves in a circle with radius

$$r = \gamma v / \tilde{\omega} \quad (59)$$

and speed

$$v = \tilde{\omega} r / \gamma = \frac{\tilde{\omega} r}{\sqrt{1 + (\tilde{\omega} r / c)^2}}. \quad (60)$$

The angular frequency  $\omega = v/r$  of the circular motion is

$$\omega = \tilde{\omega} / \gamma = \frac{\tilde{\omega}}{\sqrt{1 + (\tilde{\omega} r / c)^2}} \quad (61)$$

as above.

It follows that  $r \rightarrow \infty$  as  $v \rightarrow c$  and also that

$$v \simeq \tilde{\omega}r \quad \text{when } v \ll c \quad (62)$$

which is the nonrelativistic result.

It follows also that

$$\omega \simeq \tilde{\omega} \quad \text{when } \tilde{\omega}r \ll c \quad (63)$$

For a proton moving perpendicular to a 1.00 T magnetic field, this requires that  $r \ll 3.13$  m.

The above results limit the range of speeds attainable in a conventional particle-accelerating cyclotron which relies, as with Eq. (63), on a constant-frequency accelerating potential to increase particle speeds and a time-independent homogeneous magnetic field to make particles move in circles.

This limitation is overcome at the TRIUMF cyclotron on the UBC campus which accelerates protons to 520 MeV ( $0.75c$ ), and has a diameter of 17.1 m. This is accomplished by increasing the magnetic field with radius to accommodate the Lorentz factor  $\gamma$ . For more information on TRIUMF, see <http://www.triumf.ca>.

### Problem (10)

#### Relativistic Form of Newton's Second Law: Particle in a Magnetic Field

• Show that the momentum of a particle having charge  $e$  moving in a circle of radius  $R$  is given by  $p = 300BR$  where  $p$  is in MeV/ $c$ ,  $B$  is in teslas and  $R$  is in meters.

#### Solution

It follows from Eqs. (35) and (59) that the momentum  $p$  of a particle of charge  $e$  moving perpendicular to a constant magnetic field  $B$  is

$$p = eBR \quad (64)$$

where  $R$  is the radius of the circular orbit. Using  $e = 1.602 \times 10^{-19}$  C, MeV =  $1.602 \times 10^{-13}$  J and  $c = 3.00 \times 10^8$  m/s, it follows that

$$p = 300BR \quad (65)$$

where  $p$  is in MeV/ $c$ ,  $B$  is in teslas and  $R$  is in meters.

### Problem (11)

#### Relativistic Kinematics: Energy-Momentum Relationship

• Show that the energy-momentum relationship  $E^2 = p^2c^2 + m^2c^4$  follows from  $E = \gamma mc^2$  and  $p = \gamma mv$ .

#### Solution

See also *Notes on a Few Topics in Special Relativity* by Malcolm McMillan.

It follows from  $p = \gamma mv$  and Eq. (36) that

$$v = \frac{c}{\sqrt{1 + (mc/p)^2}} \quad (66)$$

and

$$\gamma = \sqrt{1 + (p/mc)^2} \quad (67)$$

which with  $E = \gamma mc^2$  yields

$$E = \sqrt{p^2c^2 + m^2c^4} \quad (68)$$

It follows from Eq. (66) that a particle with rest mass  $m = 0$  travels at the speed of light  $c$ .

It follows from Eq. (68) that the energy  $E$  and momentum  $p$  of a particle with rest mass  $m = 0$  are related by

$$E = pc \quad (69)$$

-----

### Problem (12)

#### Relativistic Kinematics for an Electron

Electrons in projection television sets are accelerated through a potential difference of 50 kV.

- Calculate the speed of the electrons using the relativistic form of kinetic energy assuming the electrons start from rest.
- Calculate the speed of the electrons using the classical form of kinetic energy.
- Is the difference in speed significant in the design of this set?

#### Solution

A particle with rest mass  $m$  moving with speed  $v$  has kinetic energy  $K$  given by text Eq. (1.42):

$$K = (\gamma - 1)mc^2 \quad (70)$$

where  $\gamma$  is given by Eq. (36) from which it follows that

$$v = c\sqrt{1 - [1 + (K/mc^2)^{-2}]}. \quad (71)$$

It follows from Eq. (70) that

$$K \simeq \frac{1}{2}mv^2 \quad (72)$$

when  $v \ll c$ , which is the nonrelativistic result.

An electron (rest energy 511 keV) moving through a potential difference  $V = 50$  kV acquires a kinetic energy  $K = 50$  keV.

It follows from Eq. (71) that  $v = 0.413c$ . The nonrelativistic expression Eq. (72) yields  $v = 0.442c$  which is 6% greater than the correct relativistic result.

Does it make a difference which number is used when building a TV set? If the distance between the filament off which electrons are boiled and the phosphor screen of a TV set is 50 cm, then the difference in travel times calculated relativistically and nonrelativistically is 26 ns. This time difference is too small to make a significant difference in the operation of a TV set.

---



## Problem (13)

### Relativistic Kinematics: Lorentz Invariant

The quantity  $E^2 - p^2c^2$  is an invariant quantity in Special Relativity. This means that  $E^2 - p^2c^2$  has the same value in all inertial frames even though  $E$  and  $p$  have different values in different frames.

• Show this explicitly by considering the following case: A particle of mass  $m$  is moving in the  $+x$  direction with speed  $u$  and has momentum  $p$  and energy  $E$  in the frame  $S$ . If  $S'$  is moving at speed  $v$  in the standard way, determine the momentum  $p'$  and energy  $E'$  observed in  $S'$ , and show that  $E'^2 - p'^2c^2 = E^2 - p^2c^2$ .

### Solution

See also *Notes on a Few Topics in Special Relativity* by Malcolm McMillan.

In frame  $S$ , a particle of rest mass  $m$  has velocity  $\mathbf{u}$ . Its momentum  $\mathbf{p}$  and energy  $E$  are given by text Eqs. (1.35) and (1.44):

$$\mathbf{p} = \frac{m\mathbf{u}}{\sqrt{1 - u^2/c^2}} \quad (73)$$

$$E = \frac{mc^2}{\sqrt{1 - u^2/c^2}}. \quad (74)$$

In frame  $S'$ , which moves along the  $x$ -axis of  $S$  with speed  $v$ , the velocity of the particle is  $\mathbf{u}'$  and its momentum  $\mathbf{p}'$  and energy  $E'$  are

$$\mathbf{p}' = \frac{m\mathbf{u}'}{\sqrt{1 - u'^2/c^2}} \quad (75)$$

$$E' = \frac{mc^2}{\sqrt{1 - u'^2/c^2}}. \quad (76)$$

It follows from Eqs. (73) to (76) that

$$E'^2 - p'^2c^2 = E^2 - p^2c^2 = m^2c^4. \quad (77)$$

The relationship between the momentum and energy in  $S$  and  $S'$  follows from the Lorentz velocity transformations given by text Eqs. (1.32) to (1.34):

$$u'_x = \frac{u_x - v}{1 - u_x v/c^2} \quad (78)$$

$$u'_y = \frac{u_y}{\gamma(1 - u_x v/c^2)} \quad (79)$$

$$u'_z = \frac{u_z}{\gamma(1 - u_x v/c^2)} \quad (80)$$

where  $\gamma$  is given by Eq. (2). It follows that

$$\frac{1}{\sqrt{1 - u'^2/c^2}} = \frac{\gamma(1 - u_x v/c^2)}{\sqrt{1 - u^2/c^2}} \quad (81)$$

so

$$p'_x = \gamma(p_x - \beta p_0) \quad (82)$$

$$p'_y = p_y \quad (83)$$

$$p'_z = p_z \quad (84)$$

$$p'_0 = \gamma(p_0 - \beta p_x) \quad (85)$$

where

$$p_0 = E/c. \quad (86)$$

Eqs. (82) and (85) may be written as

$$p'_x = p_x \cosh u - p_0 \sinh u \quad (87)$$

$$p'_0 = p_0 \cosh u - p_x \sinh u \quad (88)$$

where  $u$  is the rapidity:

$$\tanh u = \beta \quad (89)$$

so  $\cosh u = \gamma$  and  $\sinh u = \beta\gamma$ , from which

$$p_x = p'_x \cosh u + p'_0 \sinh u \quad (90)$$

$$p_0 = p'_0 \cosh u + p'_x \sinh u \quad (91)$$

We note that the first and fourth Lorentz spacetime transformations text Eqs. (1.25) to (1.28):

$$x' = \gamma(x - \beta x_0) \quad (92)$$

### Problem (14)

#### Einstein Mass-Energy Relationship for the Decay of the Neutron

The free neutron is known to decay into a proton, an electron and an antineutrino (of zero rest mass) according to

$$n \rightarrow p + e^- + \bar{\nu}. \quad (102)$$

This is called *beta decay*. The decay products are measured to have a total kinetic energy of  $(0.781 \pm 0.005)$  MeV.

- Show that this observation is consistent with the Einstein mass-energy relationship.

#### Solution

Using mass values given in text Appendix A ( $m_n=939.5656$  MeV/ $c^2$ ,  $m_p=938.2723$  MeV/ $c^2$ ,  $m_e=0.5110$  MeV/ $c^2$ ), it follows that

$$\Delta m = m_n - (m_p + m_{e^-} + m_{\bar{\nu}}) = 0.7823 \text{ MeV}/c^2. \quad (103)$$

By conservation of mass-energy, this decrease in rest mass energy is converted into total kinetic energy  $Q$  of the decay products as per text Eq. (1.50):  $Q = \Delta mc^2 = 0.7823$  MeV. This result is consistent with the observed value of  $(0.781 \pm 0.005)$  MeV.

### Problem (15)

#### Conservation of Energy and Momentum in Electron-Positron Annihilation

An electron  $e^-$  with kinetic energy 1.000 MeV makes a head-on collision with a positron  $e^+$  at rest. (A positron is an antimatter particle that has the same mass as the electron but opposite charge.)

In the collision the two particles annihilate each other and are replaced by two photons of equal energy, each traveling at angles  $\theta$  with the electron's direction of motion. (A photon  $\gamma$  is a massless particle of electromagnetic radiation having energy  $E = pc$ .) The reaction is

$$e^- + e^+ \rightarrow 2\gamma \quad (104)$$

- Determine the energy  $E$ , momentum  $p$  and angle of emission  $\theta$  of each photon.

Solution

The incident electron, with rest mass  $m = 0.511\text{MeV}/c^2$ , has momentum  $p$  along the positive  $x$ -axis and kinetic energy  $K$ . It follows from Eqs. (67) and (70) that

$$p = \sqrt{K(K + 2m^2c^4)}/c \quad (105)$$

from which  $p = 1.422\text{ MeV}/c$  when  $K = 1.000\text{ MeV}$ .

The total energy  $E$  of the electron and the stationary positron before the collision is

$$E = K + 2mc^2 = 2.022\text{ MeV}. \quad (106)$$

The two photons emerge from the collision each with energy

$$E_\gamma = \frac{1}{2}E = 1.011\text{ MeV} \quad (107)$$

as given by conservation of energy, and, using Eq. (69), each with magnitude of momentum

$$p_\gamma = E_\gamma/c = 1.011\text{ MeV}/c. \quad (108)$$

The momentum vectors of the photons make angles  $\pm\theta$  with the  $x$ -axis. Conservation of momentum in the  $x$ -direction is

$$p = 2p_\gamma \cos\theta \quad (109)$$

from which  $\theta = 45.3^\circ$ .

**Problem (16)**Conservation of Energy and Momentum in Neutral Kaon Decay

The  $K^0$  meson decays into two charged pions according to



The pions have equal and opposite charges as indicated and the same rest mass  $m_\pi = 140\text{ MeV}/c^2$ .

Suppose that a  $K^0$  at rest decays into two pions in a bubble chamber in which a magnetic field  $B=2.0\text{ T}$  is present.

• If the radius of curvature of the pions is 34.4 cm, determine the momenta and speeds of the pions and the rest mass of the  $K^0$ .

Solution

It follows from Eq. (65) that the momentum of each pion is  $p = 206\text{ MeV}/c$ .

It follows from Eq. (66) that the speed of each pion is  $v = 0.827c$ .

It follows from Eq. (68) that the energy of each pion is  $E = 249\text{ MeV}$ .

Conservation of energy:

$$m_K c^2 = 2E \quad (111)$$

yields  $m_K = 498\text{ MeV}/c^2$ .

## Conceptual Questions

### 1- Einstein's Postulates

1. Which of Einstein's postulates of special relativity includes a concept that does not fit with the ideas of classical physics? Explain.
2. Is Earth an inertial frame of reference? Is the Sun? Justify your response.
3. When you are flying in a commercial jet, it may appear to you that the airplane is stationary and the Earth is moving beneath you. Is this point of view valid? Discuss briefly.

### 2- Simultaneity And Time Dilation

4. Does motion affect the rate of a clock as measured by an observer moving with it? Does motion affect how an observer moving relative to a clock measures its rate?
5. To whom does the elapsed time for a process seem to be longer, an observer moving relative to the process or an observer moving with the process? Which observer measures proper time?
6. How could you travel far into the future without aging significantly? Could this method also allow you to travel into the past?

### 3- Length Contraction

7. To whom does an object seem greater in length, an observer moving with the object or an observer moving relative to the object? Which observer measures the object's proper length?
8. Relativistic effects such as time dilation and length contraction are present for cars and airplanes. Why do these effects seem strange to us?
9. Suppose an astronaut is moving relative to the Earth at a significant fraction of the speed of light.
  - (a) Does he observe the rate of his clocks to have slowed?
  - (b) What change in the rate of Earth-bound clocks does he see?
  - (c) Does his ship seem to him to shorten?
  - (d) What about the distance between stars that lie on lines parallel to his motion?
  - (e) Do he and an Earth-bound observer agree on his velocity relative to the Earth?

### 4- Relativistic Addition of Velocities

10. Explain the meaning of the terms "red shift" and "blue shift" as they relate to the relativistic Doppler effect. ?
11. What happens to the relativistic Doppler effect when relative velocity is zero? Is this the expected result?

**12.** Is the relativistic Doppler effect consistent with the classical Doppler effect in the respect that  $\lambda_{obs}$  is larger for motion away?

**13.** All galaxies farther away than about  $50 \times 10^6$  ly exhibit a red shift in their emitted light that is proportional to distance, with those farther and farther away having progressively greater red shifts. What does this imply, assuming that the only source of red shift is relative motion? (Hint: At these large distances, it is space itself that is expanding, but the effect on light is the same.)

### 5- Relativistic Momentum

**14.** How does modern relativity modify the law of conservation of momentum?

**15.** Is it possible for an external force to be acting on a system and relativistic momentum to be conserved? Explain.?

### 6- Relativistic Energy

**16.** How are the classical laws of conservation of energy and conservation of mass modified by modern relativity?

**17.** What happens to the mass of water in a pot when it cools, assuming no molecules escape or are added? Is this observable in practice? Explain.

**18.** Consider a thought experiment. You place an expanded balloon of air on weighing scales outside in the early morning. The balloon stays on the scales and you are able to measure changes in its mass. Does the mass of the balloon change as the day progresses? Discuss the difficulties in carrying out this experiment.?

**19.** The mass of the fuel in a nuclear reactor decreases by an observable amount as it puts out energy. Is the same true for the coal and oxygen combined in a conventional power plant? If so, is this observable in practice for the coal and oxygen? Explain. ?

**20.** We know that the velocity of an object with mass has an upper limit of  $c$ . Is there an upper limit on its momentum? Its energy? Explain. ?

**21.** Given the fact that light travels at  $c$ , can it have mass? Explain.?

**22.** If you use an Earth-based telescope to project a laser beam onto the Moon, you can move the spot across the Moon's surface at a velocity greater than the speed of light. Does this violate modern relativity? (Note that light is being sent from the Earth to the Moon, not across the surface of the Moon.)?.

---

## Problems & Exercises

### Simultaneity And Time Dilation

1. (a) What is  $\gamma$  if  $v = 0.250c$  ? (b) If  $v = 0.500c$  ?
2. (a) What is  $\gamma$  if  $v = 0.100c$  ? (b) If  $v = 0.900c$  ?
3. Particles called  $\pi$  -mesons are produced by accelerator beams. If these particles travel at  $2.70 \times 10^8$  m/s and live  $2.60 \times 10^{-8}$  s when at rest relative to an observer, how long do they live as viewed in the laboratory?
4. Suppose a particle called a kaon is created by cosmic radiation striking the atmosphere. It moves by you at  $0.980c$  , and it lives  $1.24 \times 10^{-8}$  s when at rest relative to an observer. How long does it live as you observe it?
5. A neutral  $\pi$  -meson is a particle that can be created by accelerator beams. If one such particle lives  $1.40 \times 10^{-16}$  s as measured in the laboratory, and  $0.840 \times 10^{-16}$  s when at rest relative to an observer, what is its velocity relative to the laboratory?
6. A neutron lives 900 s when at rest relative to an observer. How fast is the neutron moving relative to an observer who measures its life span to be 2065 s?
7. If relativistic effects are to be less than 1%, then  $\gamma$  must be less than 1.01. At what relative velocity is  $\gamma = 1.01$  ?
8. If relativistic effects are to be less than 3%, then  $\gamma$  must be less than 1.03. At what relative velocity is  $\gamma = 1.03$  ?
9. (a) At what relative velocity is  $\gamma = 1.50$  ? (b) At what relative velocity is  $\gamma = 100$  ?
10. (a) At what relative velocity is  $\gamma = 2.00$  ? (b) At what relative velocity is  $\gamma = 10.0$  ?

### 11. Unreasonable Results

(a) Find the value of  $\gamma$  for the following situation. An Earth-bound observer measures 23.9 h to have passed while signals from a high-velocity space probe indicate that 24.0 h have passed on board. (b) What is unreasonable about this result? (c) Which assumptions are unreasonable or inconsistent?

## Length Contraction

12. A spaceship, 200 m long as seen on board, moves by the Earth at  $0.970c$  . What is its length as measured by an Earth-bound observer?
13. How fast would a 6.0 m-long sports car have to be going past you in order for it to appear only 5.5 m long?
14. (a) How far does the muon in **Example 28.1** travel according to the Earth-bound observer? (b) How far does it travel as viewed by an observer moving with it? Base your calculation on its velocity relative to the Earth and the time it lives (proper time). (c) Verify that these two distances are related through length contraction  $\gamma = 3.20$  .
15. (a) How long would the muon in **Example 28.1** have lived as observed on the Earth if its velocity was  $0.0500c$  ? (b) How far would it have traveled as observed on the Earth? (c) What distance is this in the muon's frame?
16. (a) How long does it take the astronaut in **Example :** To travel 4.30 ly at  $0.99944c$  (as measured by the Earth-bound observer)? (b) How long does it take according to the astronaut? (c) Verify that these two times are related through time dilation with  $\gamma = 30.00$  as given.
17. (a) How fast would an athlete need to be running for a 100-m race to look 100 yd long? (b) Is the answer consistent with the fact that relativistic effects are difficult to observe in ordinary circumstances? Explain.

### 18. Unreasonable Results

(a) Find the value of  $\gamma$  for the following situation. An astronaut measures the length of her spaceship to be 25.0 m, while an Earthbound observer measures it to be 100 m. (b) What is unreasonable about this result? (c) Which assumptions are unreasonable or inconsistent?

### 19. Unreasonable Results

A spaceship is heading directly toward the Earth at a velocity of  $0.800c$ . The astronaut on board claims that he can send a canister toward the Earth at  $1.20c$  relative to the Earth. (a) Calculate the velocity the canister must have relative to the spaceship. (b) What is unreasonable about this result? (c) Which assumptions are unreasonable or inconsistent?

### Relativistic Addition of Velocities

**20.** Suppose a spaceship heading straight towards the Earth at  $0.750c$  can shoot a canister at  $0.500c$  relative to the ship. (a) What is the velocity of the canister relative to the Earth, if it is shot directly at the Earth? (b) If it is shot directly away from the Earth?

**21.** Repeat the previous problem with the ship heading directly away from the Earth.

**22.** If a spaceship is approaching the Earth at  $0.100c$  and a message capsule is sent toward it at  $0.100c$  relative to the Earth, what is the speed of the capsule relative to the ship?

**23.** (a) Suppose the speed of light were only  $3000\text{ m/s}$ . A jet fighter moving toward a target on the ground at  $800\text{ m/s}$  shoots bullets, each having a muzzle velocity of  $1000\text{ m/s}$ . What are the bullets' velocity relative to the target? (b) If the speed of light was this small, would you observe relativistic effects in everyday life? Discuss.

**24.** If a galaxy moving away from the Earth has a speed of  $1000\text{ km/s}$  and emits  $656\text{ nm}$  light characteristic of hydrogen (the most common element in the universe). (a) What wavelength would we observe on the Earth? (b) What type of electromagnetic radiation is this? (c) Why is the speed of the Earth in its orbit negligible here?

**25.** A space probe speeding towards the nearest star moves at  $0.250c$  and sends radio information at a broadcast frequency of  $1.00\text{ GHz}$ . What frequency is received on the Earth?

**26.** If two spaceships are heading directly towards each other at  $0.800c$ , at what speed must a canister be shot from the first ship to approach the other at  $0.999c$  as seen by the second ship?

**27.** Two planets are on a collision course, heading directly towards each other at  $0.250c$ . A spaceship sent from one planet approaches the second at  $0.750c$  as seen by the second planet. What is the velocity of the ship relative to the first planet?

**28.** When a missile is shot from one spaceship towards another, it leaves the first at  $0.950c$  and approaches the other at  $0.750c$ . What is the relative velocity of the two ships?

**29.** What is the relative velocity of two spaceships if one fires a missile at the other at  $0.750c$  and the other observes it to approach at  $0.950c$ ?

**30.** Near the center of our galaxy, hydrogen gas is moving directly away from us in its orbit about a black hole. We receive  $1900\text{ nm}$  electromagnetic radiation and know that it was  $1875\text{ nm}$  when emitted by the hydrogen gas. What is the speed of the gas?

**31.** A highway patrol officer uses a device that measures the speed of vehicles by bouncing radar off them and measuring the Doppler shift. The outgoing radar has a frequency of  $100\text{ GHz}$  and the returning echo has a frequency  $15.0\text{ kHz}$  higher. What is the velocity of the vehicle? Note that there are two Doppler shifts in echoes. Be certain not to round off until the end of the problem, because the effect is small.

**32.** Prove that for any relative velocity  $v$  between two observers, a beam of light sent from one to the other will approach at speed  $c$  (provided that  $v$  is less than  $c$ , of course).

**33.** Show that for any relative velocity  $v$  between two observers, a beam of light projected by one directly away from the other

will move away at the speed of light (provided that  $v$  is less than  $c$ , of course).

**34.** (a) All but the closest galaxies are receding from our own Milky Way Galaxy. If a galaxy  $12.0 \times 10^9$  ly away is receding from us at  $0.900c$ , at what velocity relative to us must we send an exploratory probe to approach the other galaxy at  $0.990c$ , as measured from that galaxy? (b) How long will it take the probe to reach the other galaxy as measured from the Earth? You may assume that the velocity of the other galaxy remains constant. (c) How long will it then take for a radio signal to be beamed back? (All of this is possible in principle, but not practical.)

### Relativistic Momentum

**35.** Find the momentum of a helium nucleus having a mass of  $6.68 \times 10^{-27}$  kg that is moving at  $0.200c$ .

**36.** What is the momentum of an electron traveling at  $0.980c$ ?

**37.** (a) Find the momentum of a  $1.00 \times 10^9$  kg asteroid heading towards the Earth at  $30.0$  km/s. (b) Find the ratio of this momentum to the classical momentum. (Hint: Use the approximation that  $\gamma = 1 + (1/2)v^2/c^2$  at low velocities.)

**38.** (a) What is the momentum of a  $2000$  kg satellite orbiting at  $4.00$  km/s? (b) Find the ratio of this momentum to the classical momentum. (Hint: Use the approximation that  $\gamma = 1 + (1/2)v^2/c^2$  at low velocities.)

**39.** What is the velocity of an electron that has a momentum of  $3.04 \times 10^{-21}$  kg·m/s? Note that you must calculate the velocity to at least four digits to see the difference from  $c$ .

**40.** Find the velocity of a proton that has a momentum of  $4.48 \times 10^{-19}$  kg·m/s.

**41.** (a) Calculate the speed of a  $1.00$ - $\mu$ g particle of dust that has the same momentum as a proton moving at  $0.999c$ . (b) What does the small speed tell us about the mass of a proton compared to even a tiny amount of macroscopic matter?

**42.** (a) Calculate  $\gamma$  for a proton that has a momentum of  $1.00$  kg·m/s. (b) What is its speed? Such protons form a rare component of cosmic radiation with uncertain origins.

### Relativistic Energy

**43.** What is the rest energy of an electron, given its mass is  $9.11 \times 10^{-31}$  kg? Give your answer in joules and MeV.

**44.** Find the rest energy in joules and MeV of a proton, given its mass is  $1.67 \times 10^{-27}$  kg.

**45.** If the rest energies of a proton and a neutron (the two constituents of nuclei) are  $938.3$  and  $939.6$  MeV respectively, what is the difference in their masses in kilograms?

**46.** The Big Bang that began the universe is estimated to have released  $10^{68}$  J of energy. How many stars could half this energy create, assuming the average star's mass is  $4.00 \times 10^{30}$  kg?

**47.** A supernova explosion of a  $2.00 \times 10^{31}$  kg star produces  $1.00 \times 10^{44}$  J of energy. (a) How many kilograms of mass are converted to energy in the explosion? (b) What is the ratio  $\Delta m / m$  of mass destroyed to the original mass of the star?

**48.** (a) Using data from **Table 7.1**, calculate the mass converted to energy by the fission of  $1.00$  kg of uranium. (b) What is the ratio of mass destroyed to the original mass,  $\Delta m / m$ ?

**49.** (a) Using data from **Table 7.1**, calculate the amount of mass converted to energy by the fusion of  $1.00$  kg of hydrogen. (b) What is the ratio of mass destroyed to the original mass,  $\Delta m / m$ ? (c) How does this compare with  $\Delta m / m$  for the fission of  $1.00$  kg of uranium?

**50.** There is approximately  $10^{34}$  J of energy available from fusion of hydrogen in the world's oceans. (a) If  $10^{33}$  J of this energy were utilized, what would be the decrease in mass of the oceans? (b) How great a volume of water does this correspond to? (c) Comment on whether this is a significant fraction of the total mass of the oceans.



**51.** A muon has a rest mass energy of 105.7 MeV, and it decays into an electron and a massless particle. (a) If all the lost mass is converted into the electron's kinetic energy, find  $\gamma$  for the electron. (b) What is the electron's velocity?

**52.** A  $\pi$ -meson is a particle that decays into a muon and a massless particle. The  $\pi$ -meson has a rest mass energy of 139.6 MeV, and the muon has a rest mass energy of 105.7 MeV. Suppose the  $\pi$ -meson is at rest and all of the missing mass goes into the muon's kinetic energy. How fast will the muon move?

**53.** (a) Calculate the relativistic kinetic energy of a 1000-kg car moving at 30.0 m/s if the speed of light were only 45.0 m/s. (b) Find the ratio of the relativistic kinetic energy to classical.

**54.** Alpha decay is nuclear decay in which a helium nucleus is emitted. If the helium nucleus has a mass of  $6.80 \times 10^{-27}$  kg and is given 5.00 MeV of kinetic energy, what is its velocity?

**55.** (a) Beta decay is nuclear decay in which an electron is emitted. If the electron is given 0.750 MeV of kinetic energy, what is its velocity? (b) Comment on how the high velocity is consistent with the kinetic energy as it compares to the rest mass energy of the electron.

**56.** A positron is an antimatter version of the electron, having exactly the same mass. When a positron and an electron meet, they annihilate, converting all of their mass into energy. (a) Find the energy released, assuming negligible kinetic energy before the annihilation. (b) If this energy is given to a proton in the form of kinetic energy, what is its velocity? (c) If this energy is given to another electron in the form of kinetic energy, what is its velocity?

**57.** What is the kinetic energy in MeV of a  $\pi$ -meson that lives  $1.40 \times 10^{-16}$  s as measured in the laboratory, and  $0.840 \times 10^{-16}$  s when at

rest relative to an observer, given that its rest energy is 135 MeV?

**58.** Find the kinetic energy in MeV of a neutron with a measured life span of 2065 s, given its rest energy is 939.6 MeV, and rest life span is 900s.

**59.** (a) Show that  $(pc)^2 / (mc^2)^2 = \gamma^2 - 1$ . This means that at large velocities  $pc \gg mc^2$ . (b) Is  $E \approx pc$  when  $\gamma = 30.0$ , as for the astronaut discussed in the twin paradox?

**60.** One cosmic ray neutron has a velocity of  $0.250c$  relative to the Earth. (a) What is the neutron's total energy in MeV? (b) Find its momentum. (c) Is  $E \approx pc$  in this situation? Discuss in terms of the equation given in part (a) of the previous problem.

**61.** What is  $\gamma$  for a proton having a mass energy of 938.3 MeV accelerated through an effective potential of 1.0 TV (teravolt) at Fermilab outside Chicago?

**62.** (a) What is the effective accelerating potential for electrons at the Stanford Linear Accelerator, if  $\gamma = 1.00 \times 10^5$  for them? (b) What is their total energy (nearly the same as kinetic in this case) in GeV?

**63.** (a) Using data from **Table 7.1**, find the mass destroyed when the energy in a barrel of crude oil is released. (b) Given these barrels contain 200 liters and assuming the density of crude oil is  $750 \text{ kg/m}^3$ , what is the ratio of mass destroyed to original mass,  $\Delta m / m$ ?

**64.** (a) Calculate the energy released by the destruction of 1.00 kg of mass. (b) How many kilograms could be lifted to a 10.0 km height by this amount of energy?

**65.** A Van de Graaff accelerator utilizes a 50.0 MV potential difference to accelerate charged particles such as protons. (a) What is the velocity of a proton accelerated by such a potential? (b) An electron?

**66.** Suppose you use an average of 500 kW·h of electric energy per month in your home. (a) How long would 1.00 g of mass converted to electric energy with an efficiency of 38.0% last you? (b) How many homes could be supplied

at the 500 kW·h per month rate for one year by the energy from the described mass conversion?

**67.** (a) A nuclear power plant converts energy from nuclear fission into electricity with an efficiency of 35.0%. How much mass is destroyed in one year to produce a continuous 1000 MW of electric power? (b) Do you think it would be possible to observe this mass loss if the total mass of the fuel is 104 kg ?

**68.** Nuclear-powered rockets were researched for some years before safety concerns became paramount. (a) What fraction of a rocket's mass would have to be destroyed to get it into a low Earth orbit, neglecting the decrease in gravity? (Assume an orbital altitude of 250 km, and calculate both the kinetic energy (classical) and the gravitational potential energy needed.) (b) If the ship has a mass of  $1.00 \times 10^5$  kg (100 tons), what total yield nuclear explosion in tons of TNT is needed?

**69.** The Sun produces energy at a rate of  $4.00 \times 10^{26}$  W by the fusion of hydrogen. (a) How many kilograms of hydrogen undergo fusion each second? (b) If the Sun is 90.0% hydrogen and half of this can undergo fusion before the Sun changes character, how long could it produce energy at its current rate? (c) How many kilograms of mass is the Sun losing per second? (d) What fraction of its mass will it have lost in the time found in part (b)?

#### **70. Unreasonable Results**

A proton has a mass of  $1.67 \times 10^{-27}$  kg . A physicist measures the proton's total energy to

be 50.0 MeV. (a) What is the proton's kinetic energy? (b) What is unreasonable about this result? (c) Which assumptions are unreasonable or inconsistent?

#### **71. Construct Your Own Problem**

Consider a highly relativistic particle. Discuss what is meant by the term "highly relativistic." (Note that, in part, it means that the particle cannot be massless.) Construct a problem in which you calculate the wavelength of such a particle and show that it is very nearly the same as the wavelength of a massless particle, such as a photon, with the same energy. Among the things to be considered are the rest energy of the particle (it should be a known particle) and its total energy, which should be large compared to its rest energy.

**72. Construct Your Own Problem** Consider an astronaut traveling to another star at a relativistic velocity. Construct a problem in which you calculate the time for the trip as observed on the Earth and as observed by the astronaut. Also calculate the amount of mass that must be converted to energy to get the astronaut and ship to the velocity travelled. Among the things to be considered are the distance to the star, the velocity, and the mass of the astronaut and ship. Unless your instructor directs you otherwise, do not include any energy given to other masses, such as rocket propellants.

---

---

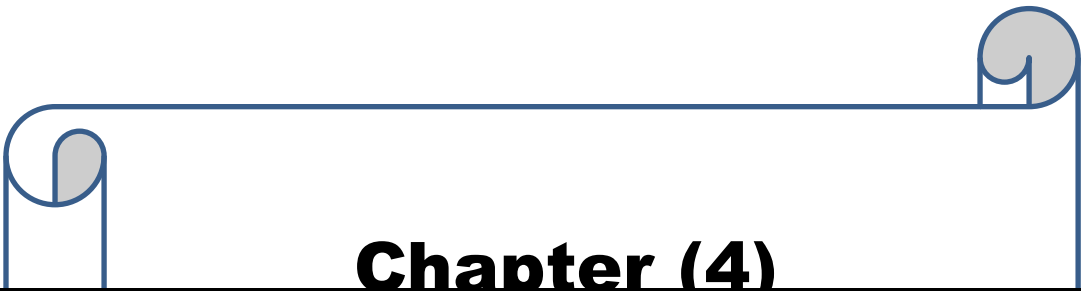
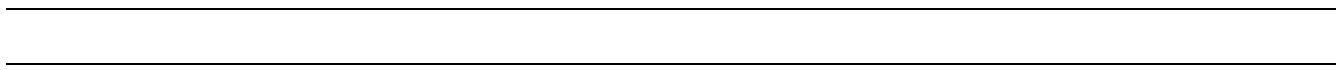

**Chapter (4)**  
**General Relativity**

## Newton's law of gravitation

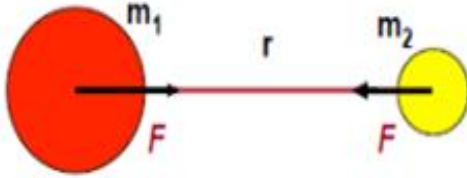

$$F = G \frac{m_1 m_2}{r^2} \quad (\text{A.25})$$

We know there are 4 forces of nature:

- Gravity, Electromagnetism, Weak & Strong Nuclear forces
- Gravity is by far the weakest force, but it is also the most obvious: it's universal, acting the same on all forms of matter

Einstein realized there that is an equivalence between gravity and acceleration: you are weightless in a plummeting elevator. This is the **equivalence principle**.

Another form of **Einstein's equivalence principle**: an observer inside an enclosed box cannot tell the difference between being at rest on Earth's surface (a) or being accelerated in outer space (b).

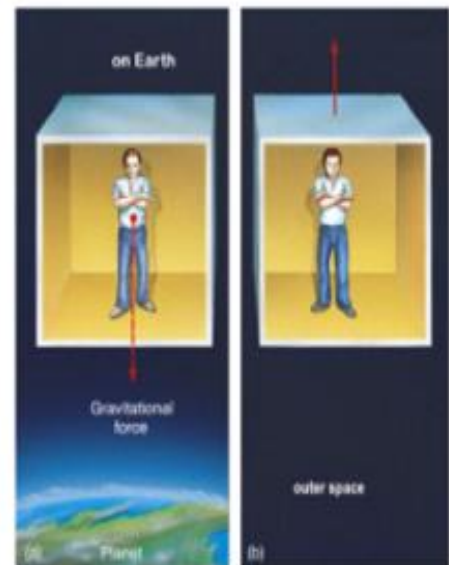

### 1. Equivalence

In Special Relativity it is asserted that all inertial reference frames are equivalent—the “laws” of physics are the same in all inertial reference frames. No experiment done in one frame can detect its uniform motion relative to another frame. Can the same be said for reference frames that have a relative acceleration?

### a. Elevator

Recall the past discussion of a person standing in an elevator. If the elevator moves perfectly smoothly and there are no floor indicator lights, then the person inside will have no perception of the elevator's motion, except for feeling perhaps the elevator floor pressing upward on his or her feet. [Keep in mind: the person gets no information from any source outside the reference frame of the elevator.] Contrast this situation with that of another person standing in a similar elevator, but this elevator is simply resting level on the Earth's surface. The person in this elevator also feels the floor pressing upward on his or her feet, also has no perception of the elevator's motion. We, as omniscient external observers, know that this second elevator is resting on the surface of a planet, and that what the person inside is experiencing is the gravitational force exerted by that planet. The point is that there is no experiment that either of the persons inside the elevators could perform that would distinguish between the two situations. Pendula would swing back and forth just the same; projectiles would follow the same kinds of arcs, etc.

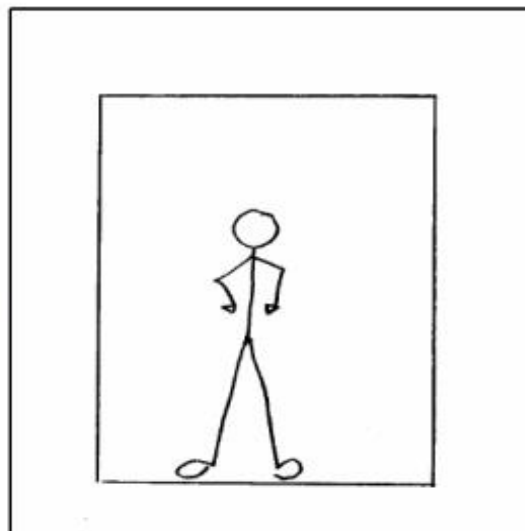

### b. Light and gravity

Imagine ourselves as observers far from any source of gravitational force. Nearby, we observe a closed "elevator" which is accelerating, relative to us, at a constant rate,  $\vec{a}_0$ . A person standing inside the "elevator" sends a series of light pulses toward one wall—he or she and we see the light pulses dropping toward the floor as they approach the wall. The light follows a curved path inside the elevator.

The Postulate of General Relativity asserts that the "laws" of physics have the same form for observers in any frame of reference, regardless of its acceleration relative to another frame. We have seen that an accelerated frame is equivalent to one in a gravitational field. It follows that the force of gravity must affect a beam of light just as it affects the motion of a massive projectile. Indeed, experiment has shown that it does. But, light has no mass.

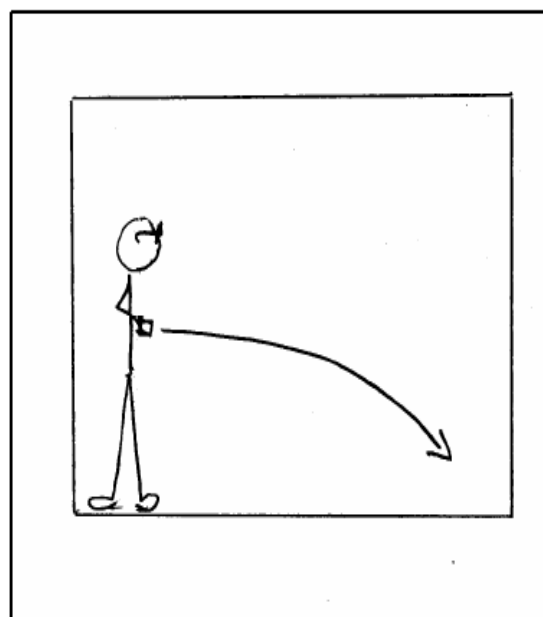



## 2. Curvature

Classically, we would say that a mass, such as a planet, exerts a gravitational force on another mass, such as a moon or a person. However, a person in an “elevator” cannot determine whether his or her “elevator” is in the gravitational field of a planet or is being accelerated at a constant rate by, say rocket motors. If the “elevator” is in a gravitational field, we can nonetheless mathematically transform the “laws” of physics into versions of the same mathematical form that do not include gravity yet which make equally accurate predictions of the motions of particles and of light beams.

What Einstein did was to formulate such a version of the “laws” of motion. Objects and light beams move always in straight lines, but in a curved space-time. Empty space-time is flat, but the presence of mass at any location curves space-time to a degree proportional to the amount of mass that is present.

In 1916 Einstein published the final form of the **General Theory of Relativity**.

We can think of gravity as a feature of the background in which we live. This background is space and time: **spacetime**

What we experience as gravity is actually **the curvature of spacetime**

In general relativity (GR), matter warps space-time, so that the straightest and shortest path (**geodesic**) looks like a curve to us.

**Mass tells space how to curve.**

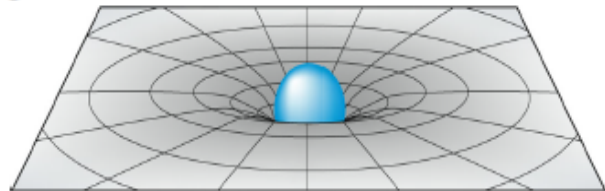

**Space tells matter how to move.**

The figure shows an analogy: weight on a tight rubber sheet depresses it (a), so a ball is deflected around it (b). That is how GR describes the motion of a planet around the Sun, and not by means of a force, as implied by Newton's gravitational force, Eq. (A.25). However, Einstein showed us that Newton's law is a limit of GR for small masses.

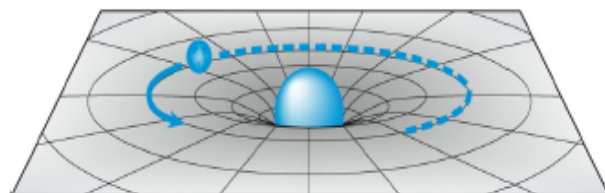

We know how to describe motion of objects exactly (remember rocket science) using Newton's gravitational law. There must be a way describe exactly the motion without forces, according to GR.

Well, it is complicated.

I will give a very short tour of GR next.

The **space-time interval**,  $\Delta s$  defined as

$$\Delta s^2 = \Delta x^2 + \Delta y^2 + \Delta z^2 - c^2 \Delta t^2 \quad (\text{A.26})$$

is Lorentz invariant. That is, if we use the Lorentz transformations with Eq. (A.13), with  $\Delta x = dx$ ,  $\Delta t = dt$ , etc., we get  $\Delta s'^2 = \Delta s^2$ .

This interval can be written in terms of the **space-time metric**

$$\Delta s^2 = \begin{bmatrix} c\Delta t & \Delta x & \Delta y & \Delta z \end{bmatrix} \begin{bmatrix} -1 & 0 & 0 & 0 \\ 0 & 1 & 0 & 0 \\ 0 & 0 & 1 & 0 \\ 0 & 0 & 0 & 1 \end{bmatrix} \begin{bmatrix} c\Delta t \\ \Delta x \\ \Delta y \\ \Delta z \end{bmatrix} \quad (\text{A.27})$$

## The space-time metric

We can rewrite the expression for the space-time interval

$$\Delta s^2 = \sum_{\mu=0,\dots,3} \sum_{\nu=0,\dots,3} \eta_{\mu\nu} \Delta x^\mu \Delta x^\nu \quad (\text{A.28})$$

where

$$\begin{aligned} x^0 &= ct & x^1 &= x \\ x^2 &= y & x^3 &= z \end{aligned}$$

(A.29)

and

$$\eta_{\mu\nu} = \begin{bmatrix} -1 & 0 & 0 & 0 \\ 0 & 1 & 0 & 0 \\ 0 & 0 & 1 & 0 \\ 0 & 0 & 0 & 1 \end{bmatrix} \begin{matrix} 0 \\ 1 \\ 2 \\ 3 \end{matrix}$$

(A.30)

It is economical to use the **Summation Notation**: the summed indices occur once as **subscripts** and again as **superscripts**:

$$\Delta s^2 = \sum_{\mu=0,\dots,3} \sum_{\nu=0,\dots,3} \eta_{\mu\nu} \Delta x^\mu \Delta x^\nu$$

(A.31)

Use of Greek letters means  $\nu = 0, 1, 2, 3$

$$\Delta s^2 = \eta_{\mu\nu} \Delta x^\mu \Delta x^\nu \quad (\text{A.32})$$

When the same index appears as a superscript and a subscript, summation is assumed, and we can omit the summation symbols.

## Tensors

In General Relativity, space is curved, and the space-time metric can be more complex. The more general metric coefficients of general relativity (which may not be -1's, 0's, and 1's) are denoted by  $g_{\mu\nu}$  :

$$\Delta s^2 = g_{\mu\nu} \Delta x^\mu \Delta x^\nu \quad (\text{A.33})$$

**Example:** An expanding (flat) universe

$$\Delta s^2 = a(t)^2 [\Delta x^2 + \Delta y^2 + \Delta z^2] - c^2 \Delta t^2 \quad (\text{A.34})$$

where  $a(t) \sim t^q$

Values of  $q$  range from  $1/2$  (in a radiation-dominated universe) to  $2/3$  (in a matter-dominated universe). (See Lecture 4).

$g_{\mu\nu}$  is a tensor. A **tensor** is a function of one or more vectors that yields a real number.  $g_{\mu\nu}$  takes two input vectors and yields a number: the interval  $\Delta s^2$ .

Because  $g_{\mu\nu}$  operates on two vectors, we say it's a tensor of **rank 2**.

**Example:** a **vector** can undergo dot products with other vectors to yield a number, so **it's a tensor of rank 1**. **Scalars have rank zero**.

The rank is also the number of indices on the tensor and the dimension of the matrix necessary to write it down.

## Geodesics

GR distinguishes between vectors and tensors that are **covariant** (with lower indices) and **contravariant** (with upper indices). To raise or lower an index, simply multiply by the metric:

$$x_\mu = g_{\mu\nu} x^\nu \quad (\text{A.35})$$

$$\Gamma_{\mu\kappa}^\alpha = g_{\mu\nu} \Gamma_{\kappa}^{\alpha\nu} \quad (\text{A.36})$$

Ordinarily, we don't usually have to worry about this because our metric is simple, and covariant and contravariant tensors are essentially the same.

To raise the indices of the metric  $g_{\mu\nu}$  itself, just take its inverse

$$g^{\mu\nu} = [g]_{\mu\nu}^{-1} \quad (\text{A.37})$$

In Newtonian space, **geodesics** are straight lines, and one way of saying this is that acceleration is zero

$$\frac{d^2 x^\alpha}{d\tau^2} = 0 \quad (\text{A.38})$$



where  $\tau$  is **proper time** (i.e., the time measured in the frame of reference of the particle), and  $x^\alpha$  is the position vs.  $\tau$  of the particle.

# Curved Spaces

In curved space, this expression generalizes to

$$\frac{d^2x^\alpha}{d\tau^2} = -\Gamma^\alpha_{\beta\gamma} \frac{dx^\beta}{d\tau} \frac{dx^\gamma}{d\tau} \quad (A.39)$$

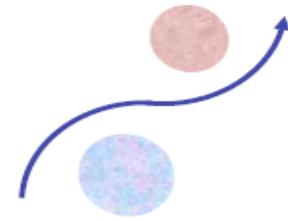

where  $\Gamma^\alpha_{\beta\gamma}$  is called a **Christoffel symbol**, given by

$$g_{\alpha\delta} \Gamma^\delta_{\beta\gamma} = \frac{1}{2} \left( \frac{dg_{\alpha\beta}}{dx^\gamma} + \frac{dg_{\alpha\gamma}}{dx^\beta} - \frac{dg_{\beta\gamma}}{dx^\alpha} \right) \quad (A.40)$$

The curvature of space-time is complicated because there are several dimensions, and the curvature at each point can be different in each dimension (including time). Think of a saddle in two dimensions for which the curvature depends on the direction.



The curvature of space-time is given by the **Ricci Tensor**

$$R_{\alpha\beta} = \frac{d\Gamma^\gamma_{\alpha\beta}}{dx^\gamma} - \frac{d\Gamma^\gamma_{\alpha\gamma}}{dx^\beta} + \Gamma^\gamma_{\alpha\beta} \Gamma^\delta_{\gamma\delta} - \Gamma^\gamma_{\alpha\delta} \Gamma^\delta_{\beta\gamma} \quad (A.41)$$

# Einstein Tensor

The **Einstein tensor** can be written in terms of the Ricci tensor as

$$G_{\mu\nu} = R_{\mu\nu} - \frac{1}{2} R g_{\mu\nu} \quad (A.42)$$

where  $R$  is the trace (i.e., the sum  $R_{\mu\mu}$ ) of the Ricci tensor

Matter's effect on space-time occurs through the **stress-energy tensor**,  $T$ .

$T_{00} = T_{tt}$  is the **mass-energy density**

$T_{10} = T_{xt}$ ,  $T_{20} = T_{yt}$  and  $T_{30} = T_{zt}$  are how fast the matter is moving – its **momentum**

$c^{-2} \cdot$  (energy density)      momentum density

$T_{00}$	$T_{01}$	$T_{02}$	$T_{03}$	] shear stress pressure
$T_{10}$	$T_{11}$	$T_{12}$	$T_{13}$	
$T_{20}$	$T_{21}$	$T_{22}$	$T_{23}$	
$T_{30}$	$T_{31}$	$T_{32}$	$T_{33}$	

momentum density      momentum flux

(A.43)

$T_{11} = T_{xx}$ ,  $T_{22} = T_{yy}$  and  $T_{33} = T_{zz}$  are the **pressures** in each of the three directions  $T_{12} = T_{xy}$ ,  $T_{13} = T_{xz}$  and  $T_{23} = T_{yz}$  are the **stresses in the matter**.

## Einstein Field Equations

The following set of coupled nonlinear partial differential equations (one for each element) relates the curvature of space,  $G_{\mu\nu}$ , to the energy-momentum tensor,  $T_{\mu\nu}$ :

$$G_{\mu\nu} = \frac{8\pi}{c^4} G T_{\mu\nu} \quad (\text{A.44})$$

Only six component equations are independent.

where  $G$  is the usual gravitational constant.

The goal is to solve for  $g_{\mu\nu}$  for all values of  $\mu$  and  $\nu$ . In free space, where  $T_{\mu\nu} = 0$ , this reduces to

$$R_{\mu\nu} = 0 \quad (\text{A.45})$$

One can show that Einstein's Field Equations reduce to Newton's law of gravity in the weak-field and slow-motion limit.

As mentioned in Lecture 3, Einstein introduced the **Cosmological constant** by modifying his equation to

$$G_{\mu\nu} + g_{\mu\nu}\Lambda = \frac{8\pi}{c^4} G T_{\mu\nu} \quad (\text{A.46})$$

## Ex: The Schwarzschild Solution

Using spherical coordinates,  $\rho$ ,  $\theta$ ,  $\phi$ , and spherical symmetry, we can solve Einstein's Field Equations (with  $\Lambda = 0$ ) for the metric to find

$$\Delta s^2 = \left(1 - \frac{2GM}{rc^2}\right)^{-1} \Delta r^2 + r^2 \Delta \Omega^2 - \left(1 - \frac{2GM}{rc^2}\right) \Delta t^2 \quad (\text{A.47})$$

The other elements of  $g_{\mu\nu}$  are zero, and  $\Delta \Omega^2 = \Delta \theta^2 + \sin^2 \theta \Delta \phi^2$

Note that, when  $R_s = 2GM/c^2$  (called the **Schwarzschild radius**), this becomes

$$\Delta s^2 = \infty \Delta r^2 + r^2 \Delta \Omega^2 - 0 \Delta t^2 \quad (\text{A.48})$$

When a star's thermonuclear fuel is depleted, no heat is left to counteract the force of gravity, which becomes dominant. The star's mass collapses into an incredibly dense ball that could warp space-time enough to not allow light to escape. The point at the center is called a **singularity**.

A collapsing star greater than 3 solar masses will distort space-time in this way to create a **black hole**.

Schwarzschild determined the radius of a black hole, known as the **event horizon**. The Schwarzschild radius is given by Eq. (4.24) in Lecture 4.

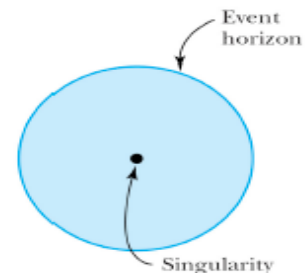

## Gravitational Waves

When a **charge accelerates**, the electric field surrounding the charge redistributes itself. This change in the electric field **produces an electromagnetic wave**, which is easily detected. Similarly, an **accelerated mass** should also **produce gravitational waves**.

Gravitational waves carry energy and momentum, travel at the speed of light, and are characterized by frequency and wavelength.

As gravitational waves pass through space-time, they cause small ripples. The stretching and shrinking is on the order of 1 part in  $10^{21}$  even due to a strong gravitational wave source.

Due to their small magnitude, gravitational waves are difficult to detect. Large astronomical events could create measurable space-time waves such as the collapse of a neutron star, a black hole or the Big Bang.

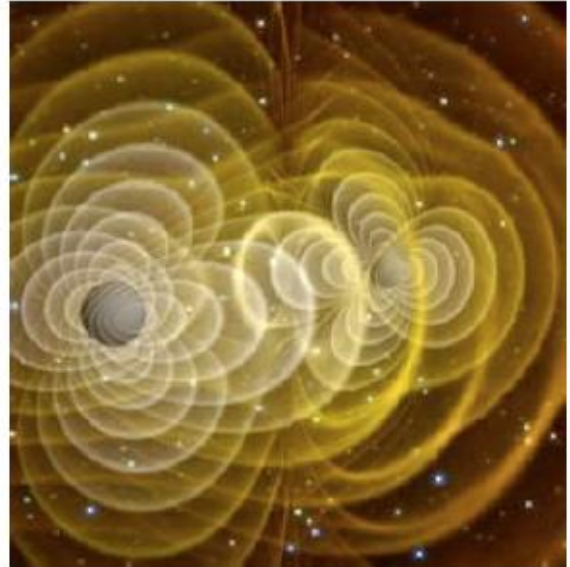

## References

---

- 1– RAYMOND A. SERWAY , et ; (2005) : "Modern Physics" Third Edition , Copyright 2005 Thomson Learning, Inc. All Rights Reserved.
- 2– Christopher R. Prior; (2005) : "Special Relativity", Science & Technology , Council Faculties.
- 3- ALBERT EINSTEIN : RELATIVITY " THE SPECIAL AND GENERAL THEORY" First published: 1920.
- 4- Sean M. Carroll : "Lecture Notes on General Relativity", Institute for Theoretical Physics, University of California, 1997 .
- 5– David Tong : "Dynamics and Relativity", Department of Applied Mathematics and Theoretical Physics, Centre for Mathematical Sciences, Cambridge, university, 2013.
- 6– W. Rindler: (1991): "Introduction to Special Relativity' (OUP) .
- 7– Masatsugu Sei Suzuki ,(2012) "Theory of special relativity", Department of Physics, SUNY at Binghamton.
- 8– Rajeb Mustafa , (2005) : "An Introduction to The Special Relativity Theory", Faculty of science.
- 9- *L. D. Landau & G. B. Rumer: "What is Relativity ? "* DOVER PUBLICATIONS, INC. MINEOLA, NEW YORK , 1960 .
- 10- Christoph Schiller : " Motion Mauntan, **relativity and cosmology**" , Twenty-ninth edition. Copyright © 1990–2016.