



SOUTH VALLY UNIVERSITY



FACULTY OF SCIENCE
AT QENA

STEREOCHEMISTRY OF CARBON COMPOUNDS BASIC CONCEPTS

Prof. Dr. Ahmed M. Abo-Bakr
Chemistry Department

For 2nd Education Students
(Chemistry & Physics)
(English)
The second Term 2024



INTRODUCTION

This course presents a brief introduction to the conceptual basis of stereochemistry, it is necessary to understand some of the language used to describe stereochemistry.

Stereochemistry is an important branch of chemistry that studies the orientation in space of the atoms of a molecule. Also, stereoisomers are molecules that differ from each other by the arrangement in space or the geometry of atoms in the molecule.

Early in the history of organic chemistry it was recognized that more than one compound could be represented by the same molecular formula and these compounds were described as isomers.

Le Bel and Van't Hoff in 1874 suggested that molecules exist in a three-dimensional form and the later development of ideas of conformation and resonance.

We shall discuss in this course some important topics Include types of geometrical isomerism, carbon hybridization , the Ingold rules, determination of the configuration of geometrical isomers, synthesis of molecules with an specific optical activity, optical isomers due to chirality, conformational analysis of both alkanes and alicyclic compounds and much more. In addition to figures, equations and schemes, it is profusely illustrated with some examples both historical and current.



Lecture 1



1. Basic Concepts

1.1 Introduction

Stereochemistry is the chemistry of space that study the molecules in three-dimensions, stereochemistry is concerned also with the relationships in space between the different atoms and groups in a molecule during the chemical reactions.

1.2 Isomers

Isomers are compounds that have the same molecular formula.

1.3 Several kinds of isomers

Isomers can be classify as follows: (Fig. 1.1)

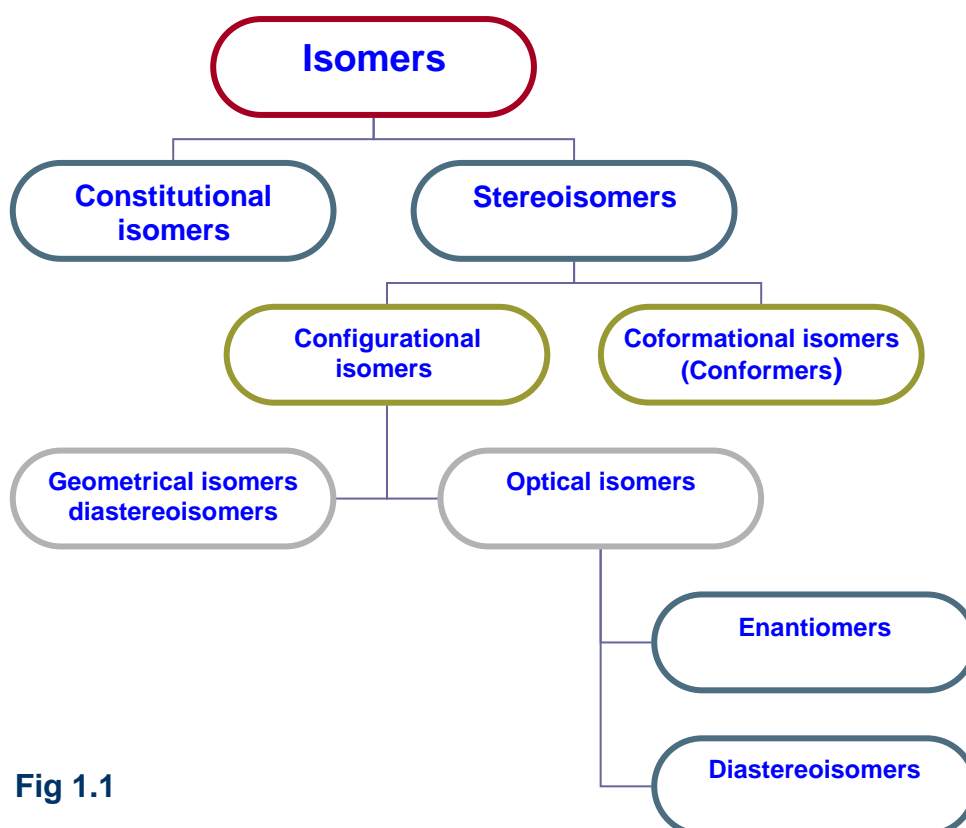

Fig 1.1



1.4 Constitutional isomers: are isomers that differ because their atoms are connected in a different order.

Example 1;

**Molecular formula
isomers**

Constitutional

C₄H₁₀

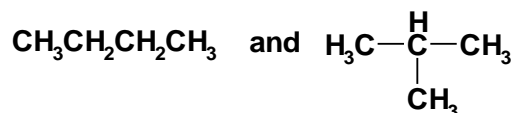

Butane

Isobutane

C₂H₆O

CH₃CH₂OH and

CH₃OCH₃

Ethanol

Dimethyl ether

Example 2;

The molecular formula **C₄H₁₀O** may take the following structures:

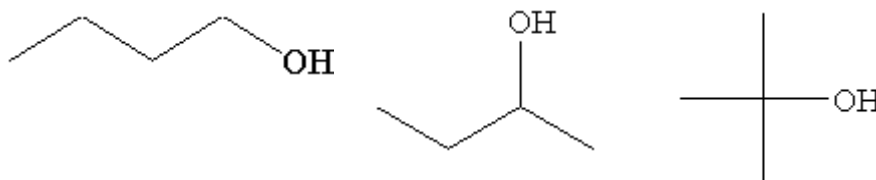

Activities: What is the relationship between the diethylketone and the pentanoic acid?

1.5 Stereoisomers: are isomers that have same formula and connectivity but differ in the position of the atoms in space

1.6 Conformational isomers: are isomers that interconvert easily at room temperature through rotations about single bonds.

Ex: Ethane molecule $\text{CH}_3\text{-CH}_3$ (Fig. 1.2).

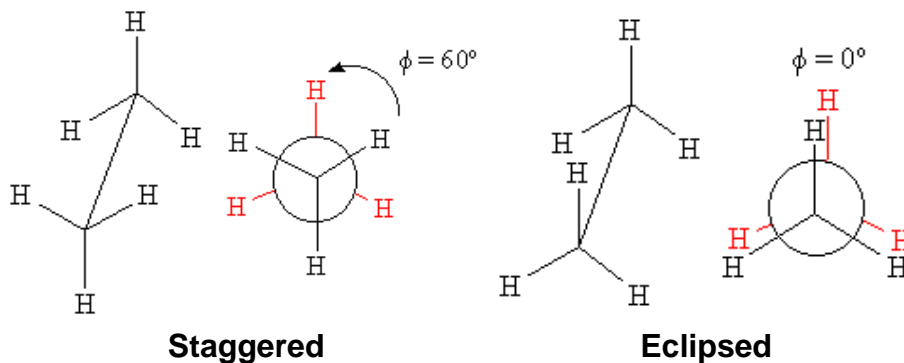

Sawhorse and Newman projections of ethane molecule

Fig. 1.2

1.7 Configurational isomers: are divided into two types optical and geometrical isomers.

1.7a Geometrical or *cis-trans* isomers: are types of stereoisomers resulting from difference in the special arrangement of the atoms or groups attached to the bonds around which rotation is largely restricted.

The most common of which are:

- 1- Compounds containing double bonds;
C=C, C=N, N=N. (see pages 21, 26 and 27)
- 2- In alicyclic compounds. (see page 27)
- 3- Biphenyl compounds.

1.7b Optical isomers: are isomers that resulting from presence of one or more chiral centers within a molecule.

Optical Activity: the ability of some compounds to rotate plane polarized light.



Chirality: refers to objects which are related as non-superimposable mirror images and the term derives from the fact that left and right hands are examples of chiral objects.

Chiral carbon atom: is a carbon atom attached to four different atoms or groups.

Ex: Alanine ($\text{H}_2\text{N}^*\text{CH}(\text{CH}_3)\text{COOH}$), in which the starred carbon atom is a chiral, being substituted by (NH_2 , H , CH_3 , and COOH) (Fig. 1.3).

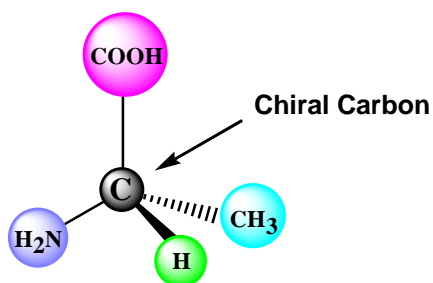

Alanine

Fig. 1.3

Achiral: any molecule that is not chiral.

Optical isomers can be divided into two general categories:

(i) Enantiomers: are two stereoisomers which differ only in their ability to rotate plane polarized light in an equal and opposite direction and each one is a mirror image to the other, and both enantiomers are non-superimposable.

(ii) Diastereoisomers: are all other stereoisomers that able to rotate plane polarized light or not, and whose molecules are not mirror images.

Note that: Enantiomers result from chirality only; diastereoisomers result from chirality or *cis-trans* isomerism.



Also, chiral system may be enantiomeric or diastereoisomeric: *cis-trans* isomers are only diastereoisomeric. (Fig. 1.4 and 1.5)

Stereoisomers	
Enantiomers	Diastereoisomers
Chirality	<i>cis-trans</i> isomersim

Fig 1.4

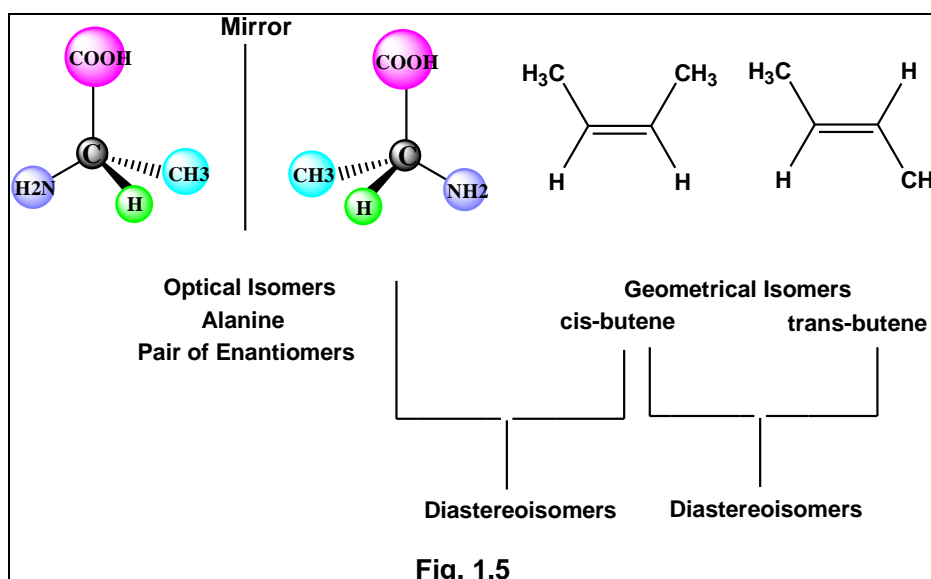

Activities: Find all the relationships between the glyceraldehyde, lactic acid and methyl 2-hydroxy acetate and classify them according to (Fig. 1.1).

Summary

- **Isomers:** different compounds which have the same molecular formula.
- **Constitutional Isomers:** Isomers which differ in "connectivity".
- **Stereoisomers:** Isomers which have the same connectivity.



- **Geometrical or *cis-trans* isomers:** are stereoisomers which resulting from difference in the arrangement of the atoms or groups attached to the bonds.
- **Enantiomers:** Stereoisomers which are mirror images.
- **Diastereoisomers:** Stereoisomers which are not mirror images.



Lecture 2



2. Hybridization of carbon

Before studying the stereochemistry it must be regards to the hybridization.

2.1 Carbon sp^3 Hybridization:

When a hydrogen atom becomes part of a molecule, it uses its $1s$ atomic orbital for bonding. The situation with the carbon atom is different. Carbon atom has six electrons two electrons in the $1s$ orbital. There are four atomic orbitals at the second energy level: one $2s$ and three $2p$. However, the four remaining electrons will be distributed as two electrons in $2s$ orbital and two electrons in $2p$ orbitals. Hence, the carbon atom in this situation should be a divalent, but in fact the carbon atom has four equivalent orbitals ready to bond with 4 hydrogen atoms and the bond angle between each C-H bond is 109.5° .

These four equivalent orbitals arise from complete hybridization (one $2s$ orbital and three $2p$ orbitals) to yield four equivalent sp^3 orbitals. For this to be accomplished of the $2s$ electrons must be promoted to the empty $2p$ orbital. This promotion requires energy (96 Kcal/mole).

The four sp^3 orbitals have equal energies slightly higher than that of the $2s$ orbital, and slightly lower than that of the $2p$ orbitals. Each one of the sp^3 orbitals contains one electron for bonding (Fig. 2.1).

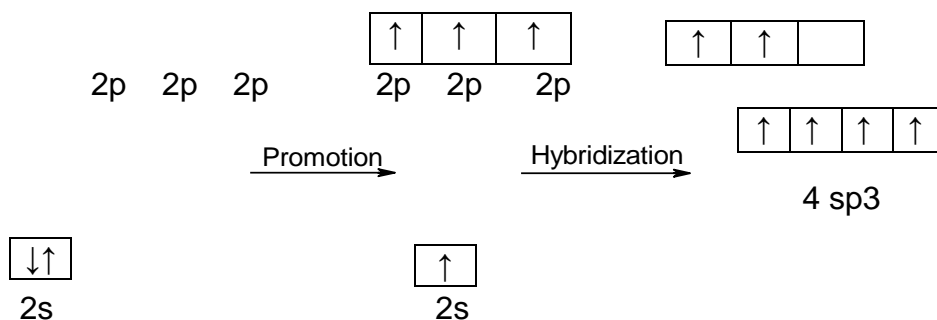
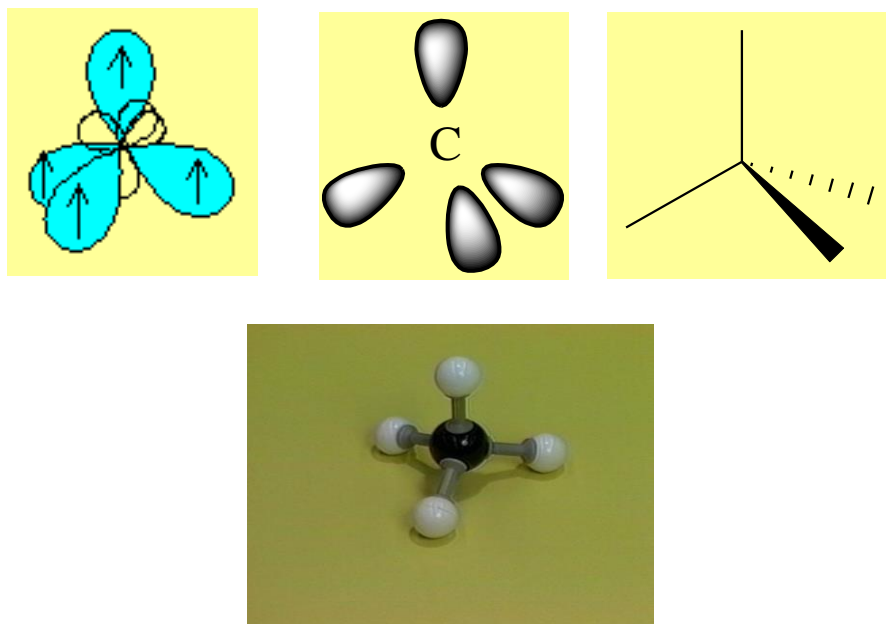

Fig. 2.1

Ex: In methane (CH_4):

Each sp^3 orbital of carbon overlaps with $1s^1$ orbital of hydrogen atom to form four sp^3 (σ) sigma bonds and represented as a regular tetrahedron. (Fig. 2.2)



Tetrahedron structure for sp^3 carbon

Ball and Stick Model of Methane to Emphasize Bonding

Fig. 2.2

2.2 Carbon sp^2 Hybridization:

When carbon atom is bonded to another atom by a double bond, the carbon atom is in the sp^2 -hybrid state.

To form sp^2 bonding orbitals, carbon hybridizes its $2s$ orbital with only two of its $2p$ orbitals. One p orbital remains unhybridized on the carbon atom. Because three atomic orbitals are used to form the sp^2 orbitals (Fig. 2.3).

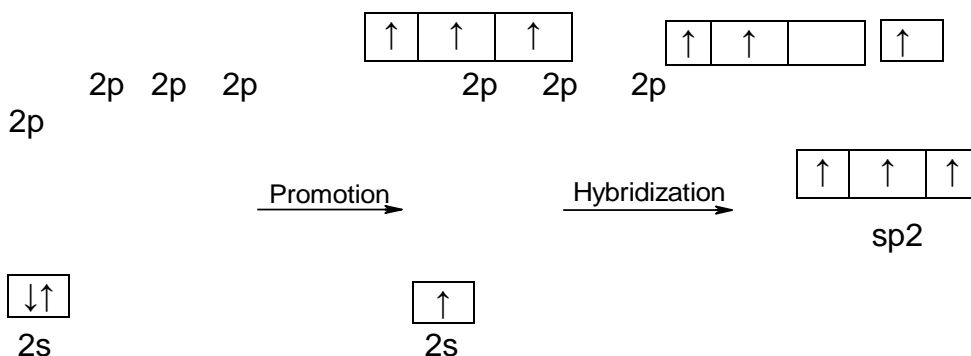

Fig. 2.3

The sp^2 orbitals have a shape similar to that of sp^3 orbitals and lie in the plane with angle of 120° between them and each sp^2 orbital contains one electron for bonding. An sp^2 hybridized carbon atom is said to be a trigonal. the one unhybridized p orbital, which is perpendicular to the sp^2 plane (Fig. 2.4).

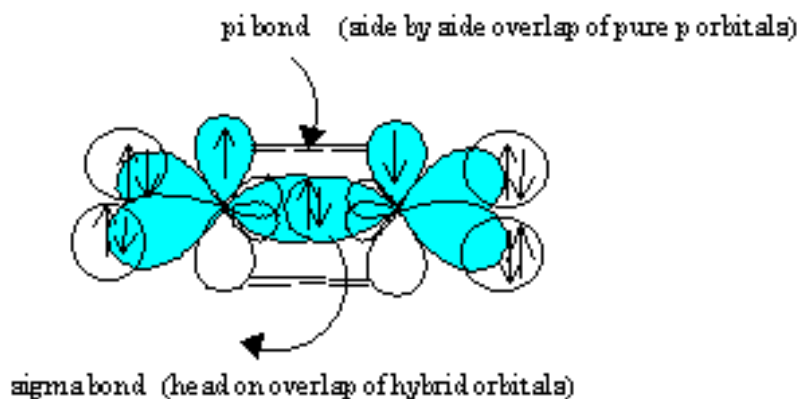
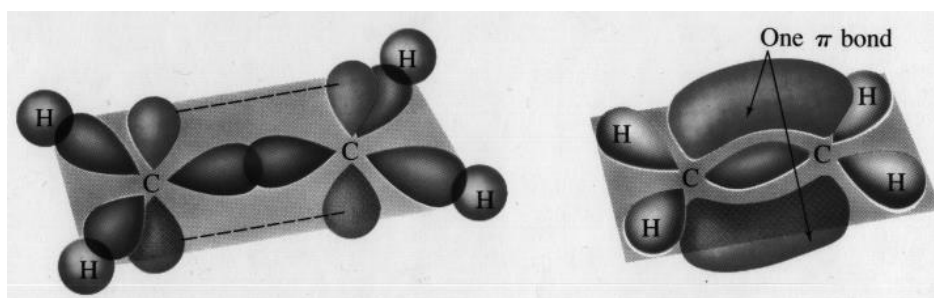

Fig. 2.4

Ex: In ethylene (CH₂=CH₂):

Two *sp*² carbons are joined by (σ) sigma bond formed by the overlap of one *sp*² orbital from each carbon atom. Each carbon atom still has two *sp*² orbitals left for bonding with hydrogen. Each *p* orbital contains one electron, since the two *p* orbitals overlap side-to-side to yield *pi* (π) bond and locate above and below the plane of the (σ) sigma bonds. The (π) bond is the second bond of the double. (Fig. 2.5)

**Fig. 2.5****2.3 Carbon *sp* Hybridization:**

When a carbon atom is joined to only other atoms, as in acetylene (CH₃CH), its hybridization state is *sp*. One *2s* orbital with only one *2p* orbital to form two *sp*-hybrid orbitals and two unhybridized *2p* orbitals remain, each with one electron. (Fig. 2.6)

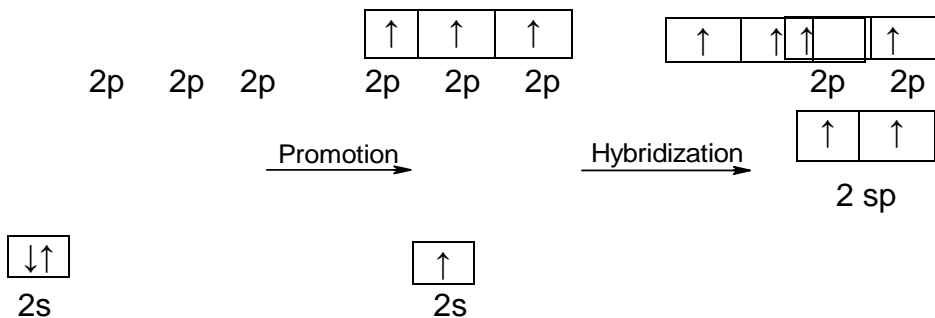
**Fig. 2.6**

The two sp orbitals lie in a straight line with an angle of 180° between them. The two p orbitals are perpendicular to each other and to the line of sp orbitals.

Ex: In acetylene ($\text{CH}\equiv\text{CH}$):

The two carbon atoms are joined by an $sp-sp$ (σ) bond. Each carbon is also bonded to a hydrogen atom by an $sp-s$ (σ) bond. The two p orbitals of one carbon then overlap with the two p orbitals of the other carbon to form two (π) bonds. (Fig. 2.7)

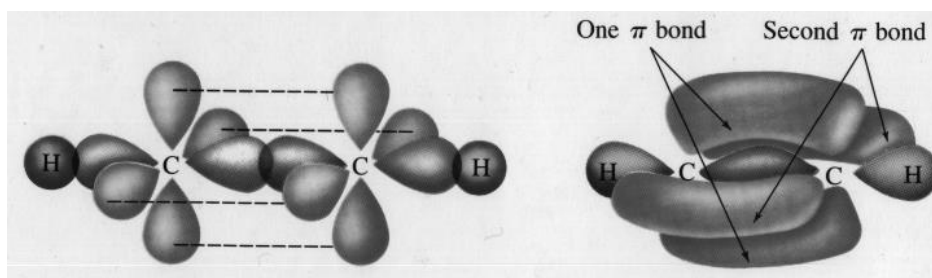

Fig. 2.7

Activities: Draw in space the following molecules in three dimensions according to the hybridization angles;



Summary

- **Carbon sp^3 Hybridization:** in which 4 equivalent orbitals arise from complete hybridization (one $2s$ orbital and three $2p$ orbitals) to yield four equivalent sp^3 orbitals have equal energies with angle of $109^\circ 28'$ and each one contains one electron for bonding.
- **Carbon sp^2 Hybridization:** in which 3 equivalent orbitals arise from complete hybridization (one $2s$ orbital and two $2p$ orbitals) to yield 3 equivalent sp^2 orbitals with angle of 120° and one p orbital remains unhybridized .



- **Carbon sp Hybridization:** in which 2 equivalent orbitals arise from complete hybridization (one 2s orbital and one 2p orbitals) to yield 2 equivalent sp orbitals with angle of 180° and two p orbitals remain unhybridized .

Lecture 3

3. Geometrical isomerism (*cis-trans*-isomerism)

3.1 Geometrical isomerism due to carbon-carbon double bond

A. Restricted rotation about the olefinic bond

Structures containing double bonds exhibit geometrical isomerism. This type of stereoisomerism is designated *cis*-, *trans*-isomerism. If the alkene is designated as $\text{abC}=\text{Cab}$ or $\text{abC}=\text{Ccd}$, then it will exist in two forms so long as $\text{a}\neq\text{b}$ and $\text{c}\neq\text{d}$. When identical groups are situated on the same side, the isomer is known as the *cis*-form whereas the prefix *trans*- is used for an opposite arrangement of identical groups. Three possible types are shown in (Fig. 3.1).

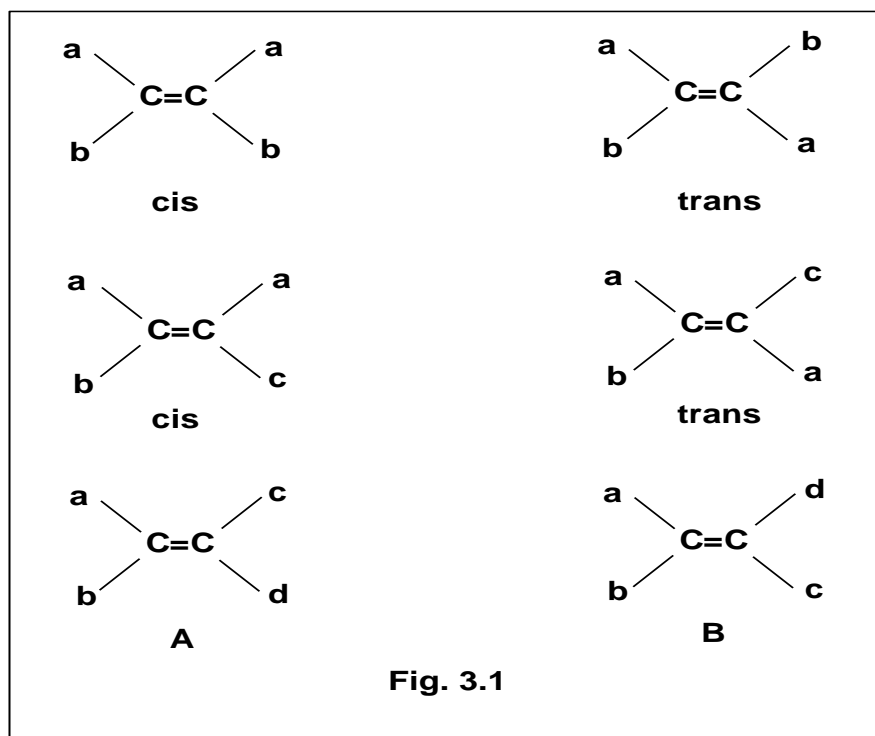

Activities: What are the conditions should be present in the structures containing double bonds to exhibit geometrical isomerism?

B. Designation of configuration

The prefixes "*cis*" and "*trans*" being used when the two equal groups are on the same or opposite sides. This configurational in which all four substituents are different (A and B, Fig. 3.1) is applicable to ethylene.

Now, what happens when the terms *cis* and *trans* can not be used?

3.2 The symbols (*E*) and (*Z*)

The new terms (*E*) and (*Z*) replace the older terms (*cis*) and (*trans*). The method is based on a priority system developed by Cahn, Ingold and Prelog (1956, 1966) for use with optically active molecules. Groups on each carbon atom of the double bond are assigned a first (1) or second (2) then priority compared at one carbon relative to the other.

When both first priority groups are on the same side of the double bond, the configuration is designated as *Z* (zusammen, together). If the first priority groups are on the opposite sides, the designation is *E* (entgegen, across) (Fig. 3.2).

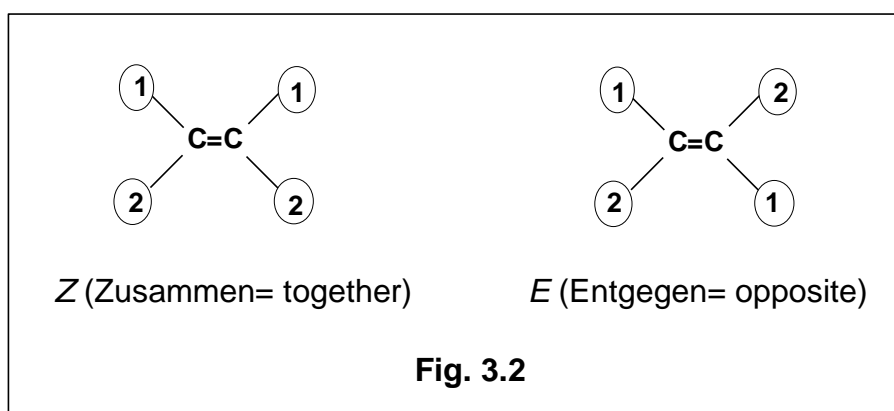

In the Cahn- Ingold- Prelog system, a set of sequence rules to determine order of priority has been developed.

3.3 The sequence rules

The rules we shall use state as follow:

(i) Higher priority is assigned to atoms of higher atomic number.

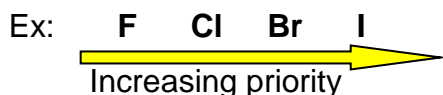

(ii) If two isotopes of the same element are present, the isotope of higher mass is the higher priority.



Increasing priority

(iii) When two atoms have the same priority attached directly to a double bond, the second atoms are considered.

Ex: Z-3-ethyl-2-hexene.

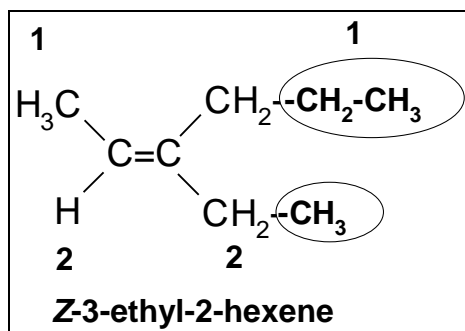

(iv) When groups under priority determination have double or triple bonds, the multiply- bonded atom is replaced conceptually by two or three single bonds to that same kind of atom (Fig. 3.3).

For Example:

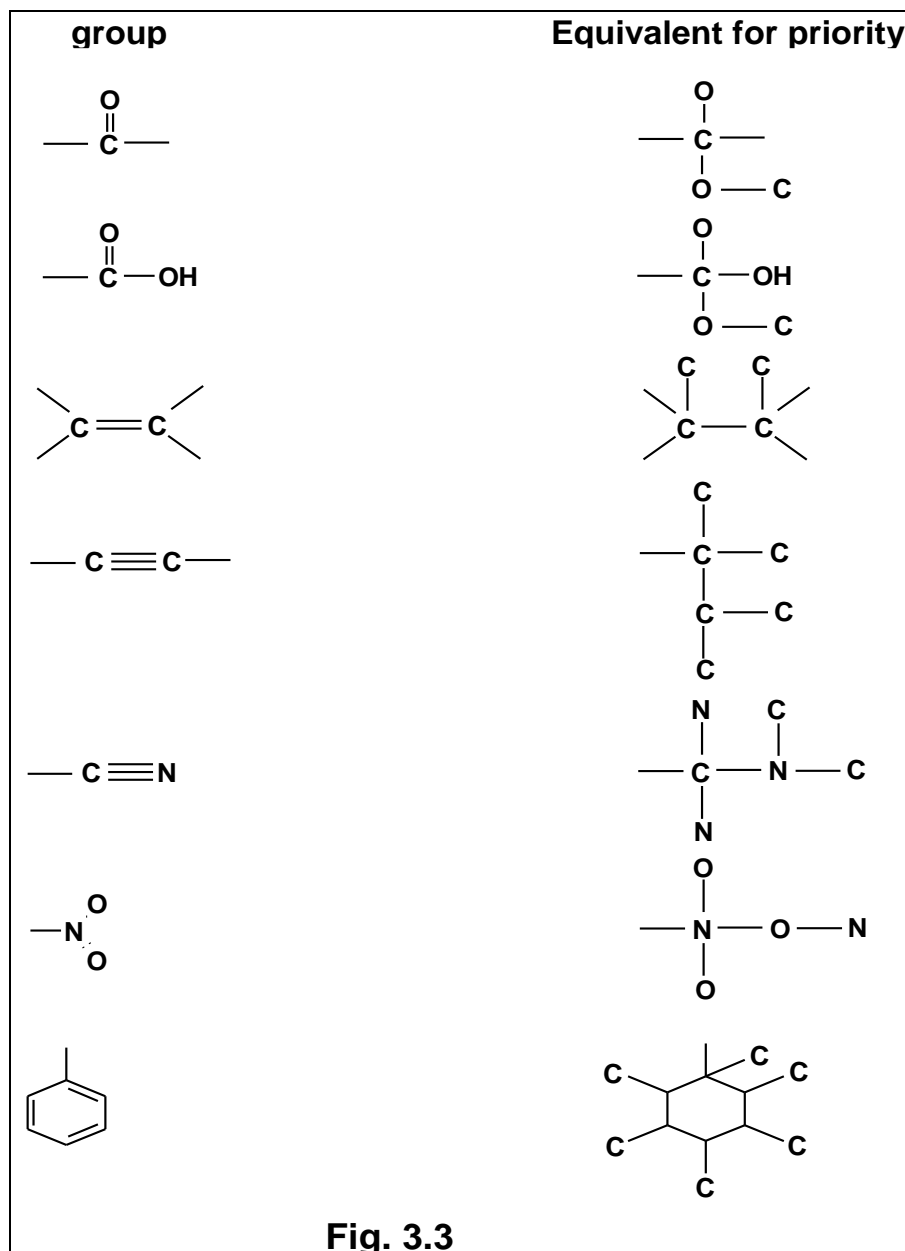

(v) Lone-pair electrons are regulated as an atom with atomic number 0.

(vi) Proximal groups take priority over distal groups.

- The order of decreasing priority of some atoms and groups is arranged as the following:

Decreasing priority



Atoms: I, Br, Cl, S, P, F, O, N, C, H, lone-pair electrons.

Groups: -OCOR, -OR, OH.

-NO₂, -NR₂, -NHCOR, -NHR, -NH₂.

-COCl, -COOR, -COOH, -CONH₂, -COR, -CHO.

-C(R)₂OH, -CH(R)OH, -CH₂OH.

-CN, -C₆H₅, -C≡CR, -C≡CH, -C=CH₂, -CH(CH₃)₂.

-C(R)₃, -CH(R)₂, -CH₂R, -CH₃.

Activities:

1- Arrange the following groups in order of increasing priority:

(i) -OCH₃, -NHCH₃, -SO₃H, -Cl.

(ii) -OCH₂C(CH₃)₃, -OCH₂CH₂Cl, -OEt, -CHCl₂.

2- Provide a name, including an *E* or *Z*- designation, for each of the following:

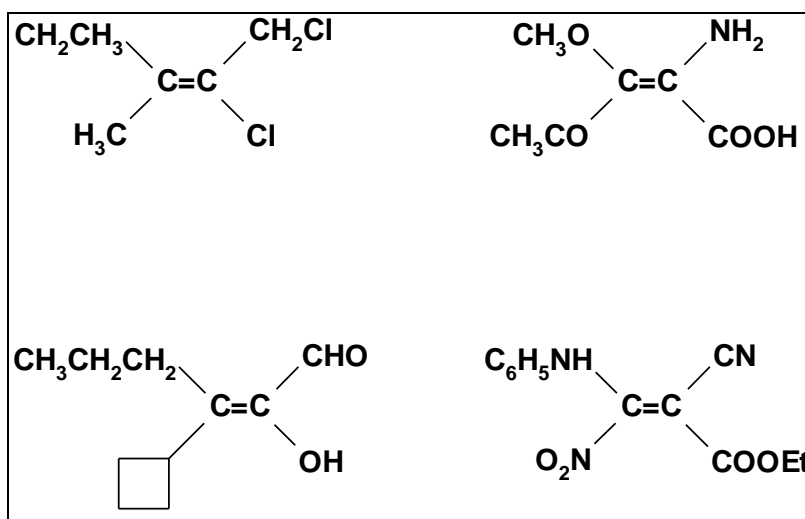

3.4 Stereoisomerism in compounds with more than C=C group

The number of geometrical isomers increase when a molecule contains more than one C=C group. If the terminal double bonds are not identical, e.g., aHC=CH-CH=CHb, $a \neq b$. The number of geometrical isomers = 2^n , where (n) is the No. of double bonds (Fig. 3.4).

If the terminal double bonds are identical, e.g., aHC=CH-CH=CHa, the No. of isomers =3 (Fig. 3.4).

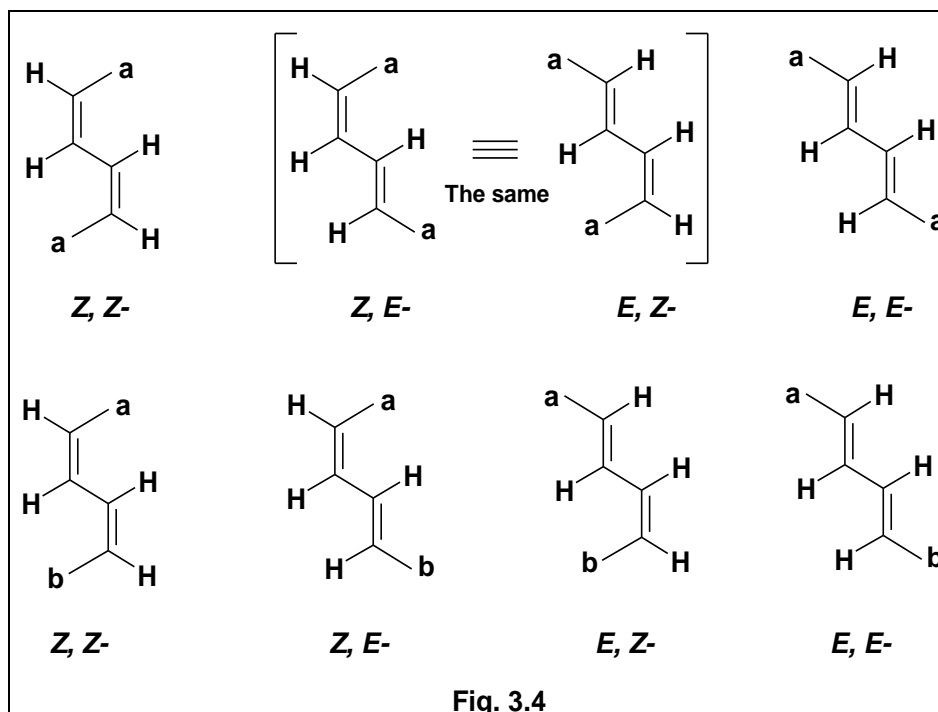

EX: *hepta-2,4-diene* is has a terminal double bonds exists as 4 geometrical isomers (Fig. 3.5).

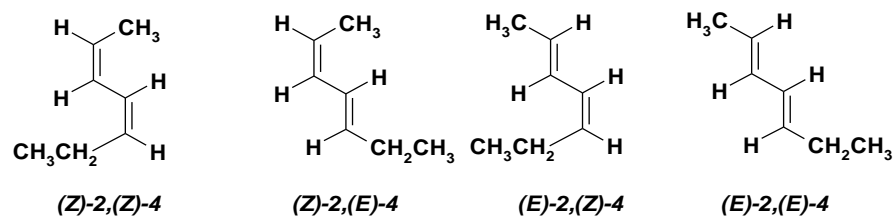

Activities:

i- Structure (A) is one stereoisomer of *E,E*-1,4-dichlorobuta-1,3-diene. Provide with structures and names of the other two stereoisomers.

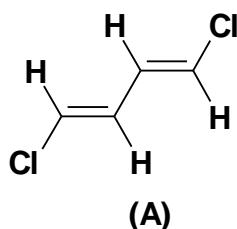

ii- Formulate and name the possible stereoisomers of octa-2,5-diene.

3.5 Geometrical isomerism due to carbon-nitrogen (C=N) double bond

The illustrative examples of compounds in which geometrical isomerism is due to the presence of carbon-nitrogen double bond are oximes.

Nitrogen in which one *sp*² orbital contains only a lone pair of electrons. Here again, restricted rotation due to the π -bond leads to existence of cis-trans isomers if the carbon atom attached to two different atoms or groups.

In aldoxime, there are two geometrical forms which are designated by the prefixes *syn-* (*E*) and *anti-* (*Z*), the *syn*-isomer is the one in which the **H** and **OH** lie *cis* to each other, the *anti*-isomer is the one in which these are *trans* to each other as shown in the following example (Fig. 3.6).

Ex: benzaldoxime.

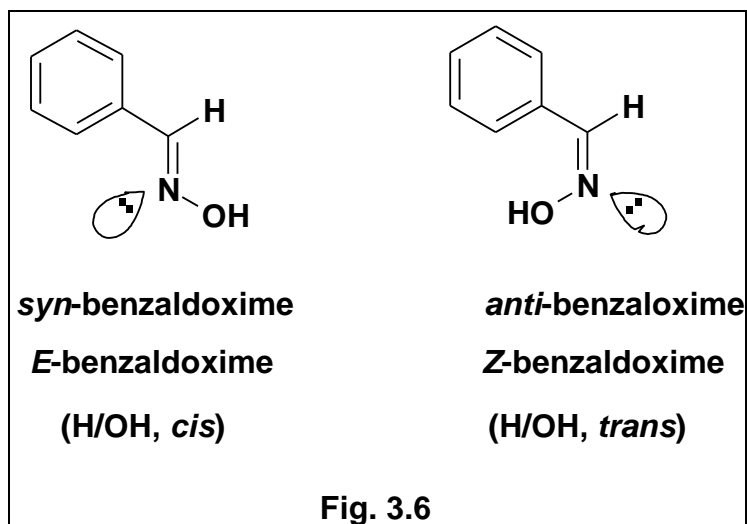

In the past, the above special prefixes have been used to designate these isomers, but this is now satisfactorily achieved by the use of (*E*) and (*Z*).

3.6 Geometrical isomerism due to nitrogen- nitrogen (N=N) double bond

The rigidity within a molecule contains **N=N** exhibits two geometrical isomers as in azo – compounds (Fig. 3.7).

Ex: Azobenzene **Ph-N=N-Ph**.

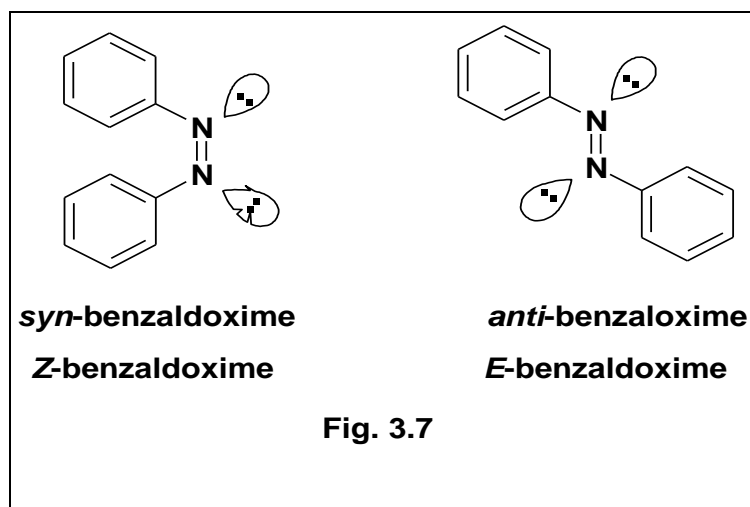

3.7 *cis-trans*- isomerism in cyclic compounds

In alicyclic compounds also, the rigidity of atoms in rings to rotate completely about their bonds leads to *cis-trans*-isomerism as shown in the next example (Fig. 3.8).

Ex: *cis-trans*- isomers of 1,2-dimethylcyclopropane.

The *cis*- isomer has both methyls on the same side of the ring; the *trans*- isomer has them on opposite sides.

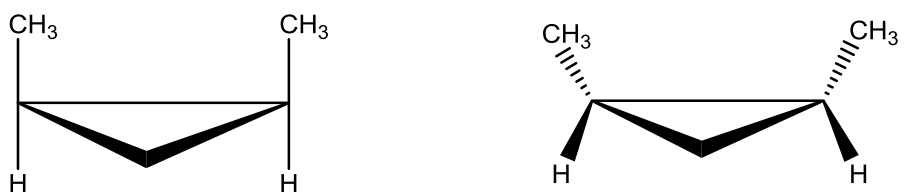

cis-1,2-dimethylcyclopropane



trans-1,2-dimethylcyclopropane

Fig. 3.8

Activities: Try to draw any substituted cycloalkanes and Provide them with a name, including *cis-* or *trans-* designation, for each one.

Summary

- The alkene is designated as $abC=Cab$ or $abC=Ccd$, $a \neq b$ and $c \neq d$. When identical groups are situated on the same side, the isomer is known as the *cis*-form whereas the prefix *trans* is used for an opposite.

- The new terms (**E**) and (**Z**) replace the older terms (**cis**) and (**trans**), where
- When both first priority groups are on the same side of the double bond, the configuration is designated as **Z**, whereas the prefix **E** is used for an opposite.
- **Priority Rules**
- Higher priority is assigned to atoms of higher atomic number.
- The element isotope of higher mass is the higher priority.
- When two atoms have the same priority attached directly to a double bond, the second atoms are considered.
- Double and triple bonds are counted as if they were split into two or three single bonds, respectively.
- Lone-pair electrons are regulated as an atom with atomic number 0.
- Proximal groups take priority over distal groups.
- The number of geometrical isomers = 2^n , where (**n**) is the No. of double bonds.
- In aldoxime, the **syn**-isomer is the one in which the **H** and **OH** lie **cis** to each other, the **anti**-isomer is the one in which these are trans to each other.

Lecture 4

4. Determination of the configuration of geometrical isomers

4.1 Which compound has which structure?

The methods are used for the determination of configuration of olefinic geometrical isomers as shown in (Fig. 4.1).

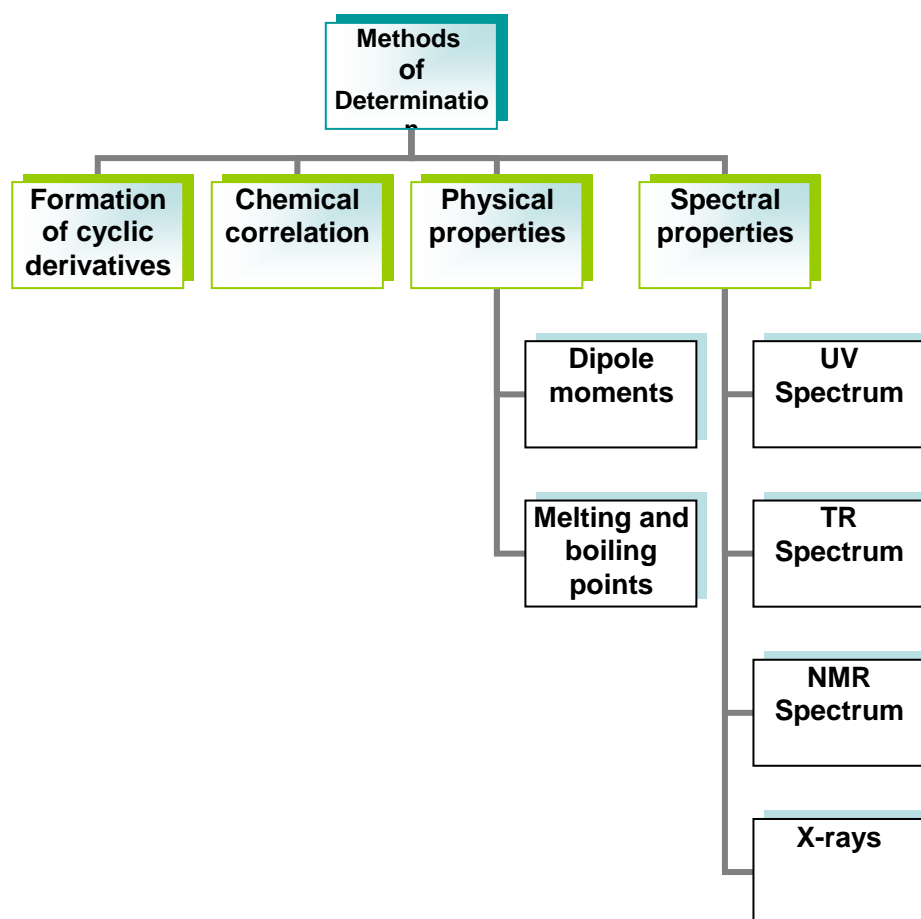

Fig. 4.1

Two of the above methods will be discussed in this section as follows:

4.2 Formation of cyclic derivatives

This is illustrated by the behavior of maleic and fumaric acids, both of which have the general formula:



Maleic acid (mp 130°) readily forms a monomeric anhydride upon heating to $\sim 140^{\circ}$. Water regenerates the acid from its anhydride. Fumaric acid (mp 270°) does not readily form an anhydride upon heating to $\sim 140^{\circ}$, but vigorous heating to $\sim 276^{\circ}$ is converted it to the anhydride of maleic acid. It may be concluded that the two carboxylic groups must be on the same side of the alkene double bond system in maleic acid and on the opposite side in fumaric acid. Hence, maleic acid is the *cis*-isomer and fumaric acid is the *trans* (Fig. 4.2).

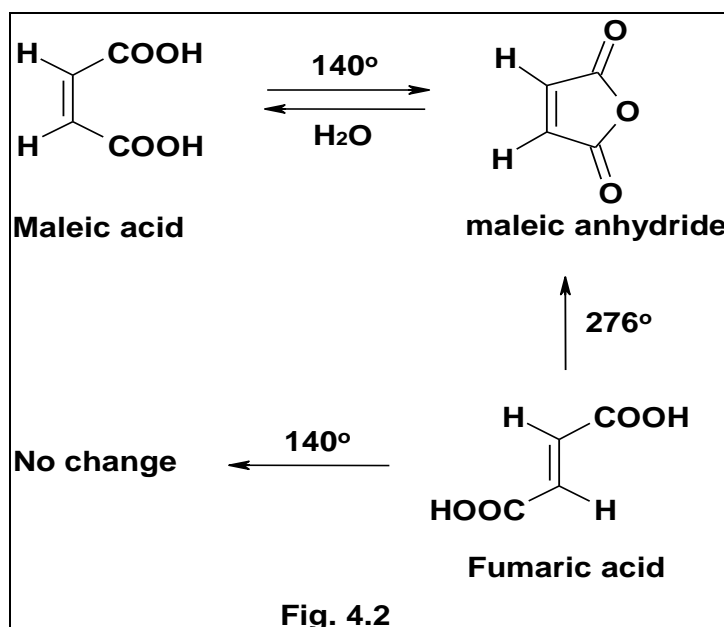

Activities: 2-methyl-2-butenedicarboxylic acid can not lose a molecule of water. Is 2-methyl-2-butenedicarboxylic acid exists in the *cis*- or in the *trans*- form?

4.3 Chemical correlation

This method depends on conversion of unknown configurational isomer into a different known isomer.

An example of the correlation method is the transformation of trichlorocrotonic acid (mp 114^o), into fumaric acid by hydrolysis, and by reduction into crotonic acid (mp 72^o). Since fumaric acid has the **trans** configuration, the trichlorocrotonic acid and the crotonic acid must also be **trans**-isomers (Fig. 4.3).

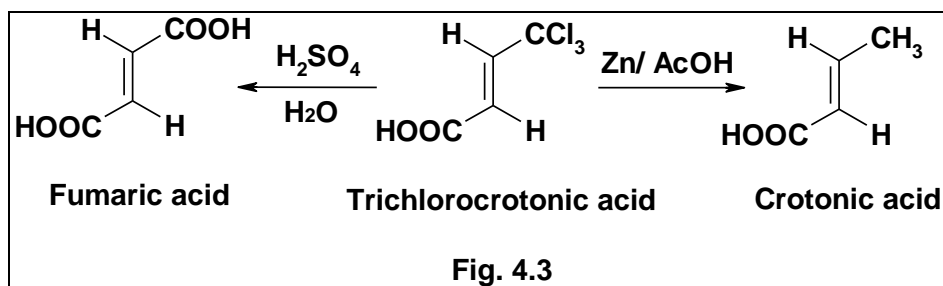

Also, several of the physical and spectral methods of assigning configuration used, e.g., Dipole moment measurements; Melting points; Infrared spectra; Ultraviolet spectra; Nuclear Magnetic Resonance spectra and X-rays. These methods are also quite reliable.

4.4 Can *cis*- and *trans*- isomers be interconvert ?

The conversion of *cis*- to *trans*-isomers or the reverse process is known as **stereomutation** which can be affected in two ways: either by a series of chemical reactions by which the alkene is converted to the other alternative isomer or by the reversible procedure converting the double bond to single bond in which free rotation is possible before regeneration of the alkene. This reversible process may be affected by free radical, by pyrolysis, and by vigorous heating (Fig. 4.4).

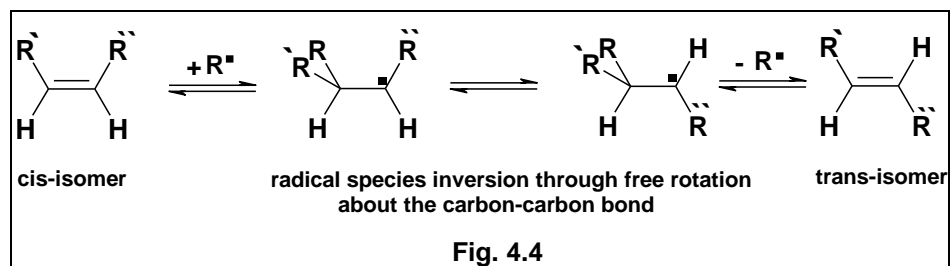

Summary

- The methods are used for the determination of configuration of geometrical isomers

(i) Formation of cyclic derivatives: which based on the isomer in

which two attached groups are closer to each other (i.e., **cis**) will be converted into a cyclic compound.

(ii) Chemical correlation: which based on conversion of unknown

configurational isomers into compounds of known configuration.

- Stereomutation:** is a conversion of cis to trans-isomers or the reverse process.

Lecture 5

Lecture 6

5. Representing three-dimensional molecules in two-dimensions

The most common representations for the spatial relationship between ligands attached to two adjacent carbon atoms are Fisher projections, Wedge projections, Sawhorse projections and Newman projections. Each has its merits and it is important to understand all these projections to be able to represent the three-dimensional structures of molecules in two-dimensional drawings, and to interconvert each one to the other.

The several representative projections were listed as the following:



5.1 Fischer Projections

In which The main carbon chain is drawn as a vertical line and bonds to all substituents are drawn as horizontal lines. All vertical lines represent bonds behind the plane of the page and all horizontal lines represent bonds in front of the plane of the page.

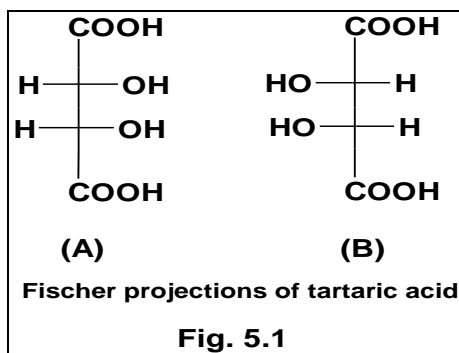
Tartaric acid for example can be represented by Fischer projection as in (Fig. 5.1).



5.2 Wedge projections

A wedge representation shows the side of the carbon—carbon bond being drawn. The wedges () represent bonds that project out of the plane of the paper toward you, the lines are bonds in the plane of the paper, and the dashed wedges () represent bonds receding away from you behind the plane of the paper.

Tartaric acid for example can be represented by Wedge projection as in (Fig. 5.2).

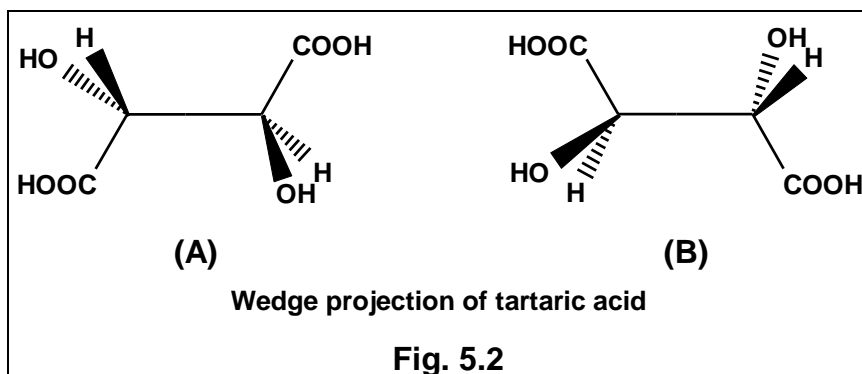

5.3 Sawhorse projection

Sawhorse projection views the molecule from slightly above and to the right of one carbon-carbon bond and all bonds are drawn as straight lines.

Tartaric acid can be represented by Sawhorse projection as in (Fig. 5.3).

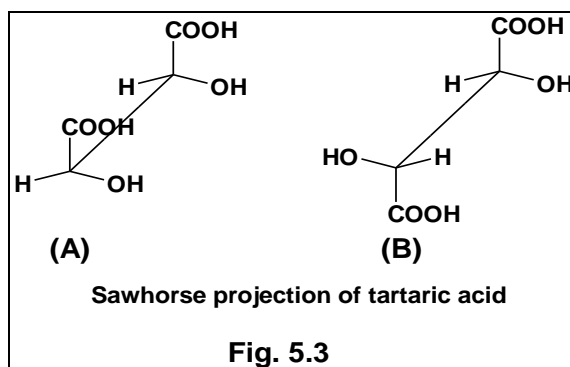

Activities: Draw the Fischer, Sawhorse and Wedge projections formula for the Erythro-2,3-difluorobutanecarboxylic acid.

5.4 Newman projections

A Newman projection shows the two bonded carbons under consideration with one directly in front of the other. The point represents the front carbon and the open circle represents the rear carbon.

Tartaric acid can be represented by Newman projection as in (Fig. 5.4).

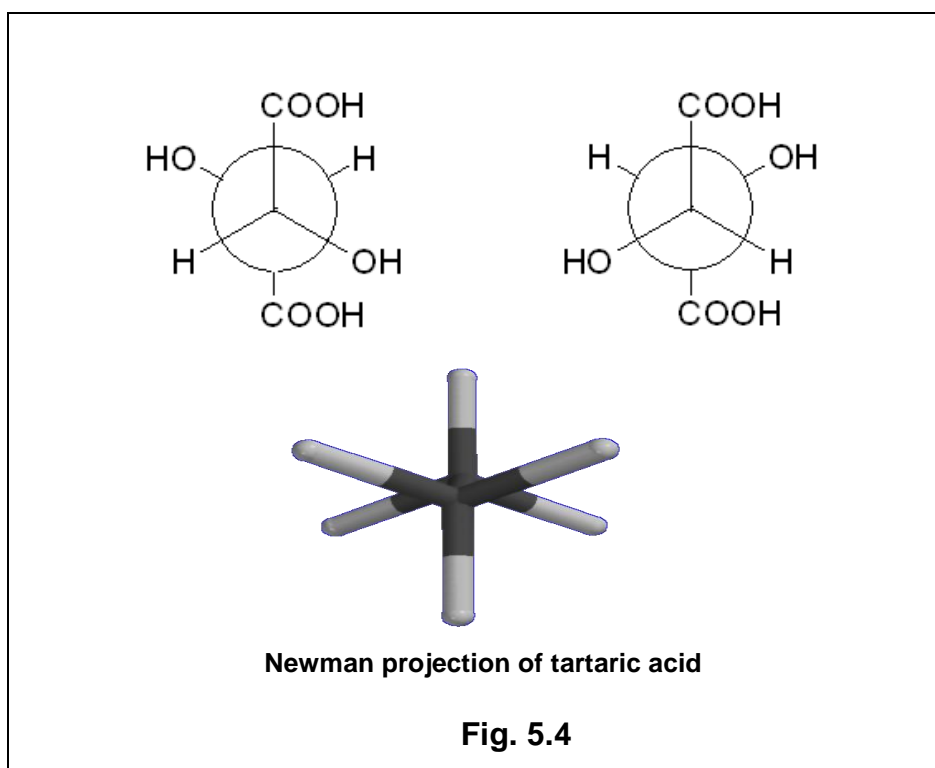

6. Optical isomerism

It's necessary referring to optical isomerism which help us to understand the next sections.

6.1 Optical Activity: the ability of some compounds to rotate plane polarized light.

Le bel and Van't Hoff in 1874 proposed that the optical activity of organic compounds is due to the presence of asymmetric carbon atoms.

6.2 Optical Isomerism due to asymmetric carbon atoms

These isomers do not differ in their chemical properties and most physical properties. However, they differ in their action towards plane polarized light. Plane polarized light has all the light rays vibrating in one plane and the property, because of which certain substance rotate its plane of polarization, is known as optical activity.

6.3 Definitions

A- compounds with one asymmetric (chiral) carbon atom:

The simplest source of dissymmetry (asymmetric center) in an organic molecule is a chiral carbon atom.

Chiral carbon atom: is a carbon atom attached to four different atoms or groups. Denoting these atoms or groups by **a**, **b**, **c** and **d**, the general symbol for chiral carbon becomes **Cabcd** (Fig. 6.1).

Ex1: Lactic acid ($\text{CH}_3^*\text{CH}(\text{OH})\text{COOH}$), in which the starred carbon atom is a chiral, being substituted by (**H**, **OH**, **CH₃** and **COOH**) (Fig. 6.1).

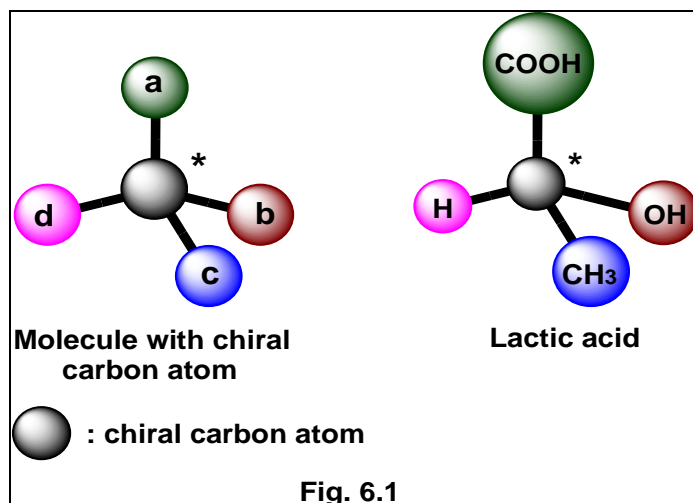

A molecule has a chiral carbon atom may exist as a pair of isomers said to be enantiomers [the (+) –form known as "Dextrorotatory" and the (-) –form known as "Levorotatory"].

Enantiomers: are stereoisomeric pair have the same chemical and physical properties but differ in the rotation of plane polarized light, one of them is mirror image of the other (Fig. 6.2).

Dextrorotatory (+): an optically active compound that rotates plane polarized light in a clockwise direction.

Levorotatory (-): an optically active compound that rotates plane polarized light in a counterclockwise direction.

An enantiomer: is one of a pair of stereoisomers that are related as non–superimposable mirror images.

Diastereoisomers: are stereoisomers that have different chemical and physical properties in any type of environment and not to be enantiomers.

A racemic mixture: is a 50:50 mixture of the 2 enantiomers of a chiral compound. It is optically inactive and its components can be separated by a process described as resolution. A racemic mixture may be prefixed by the symbols (\pm).

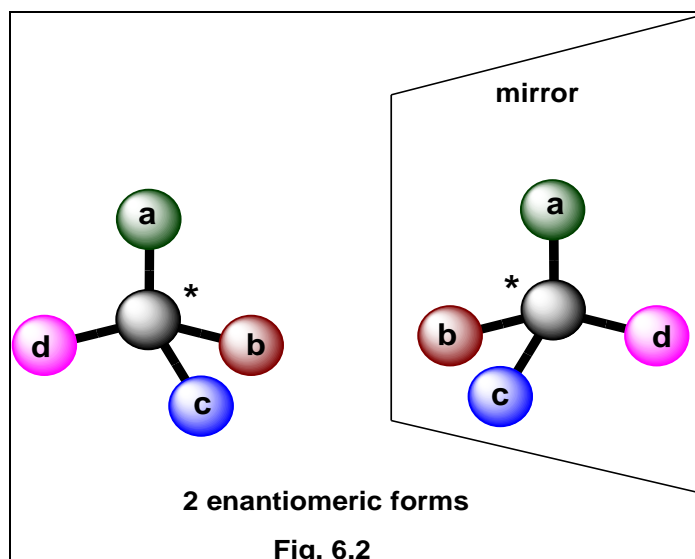

Ex2: Glyceraldehyde (Fig. 6.3).

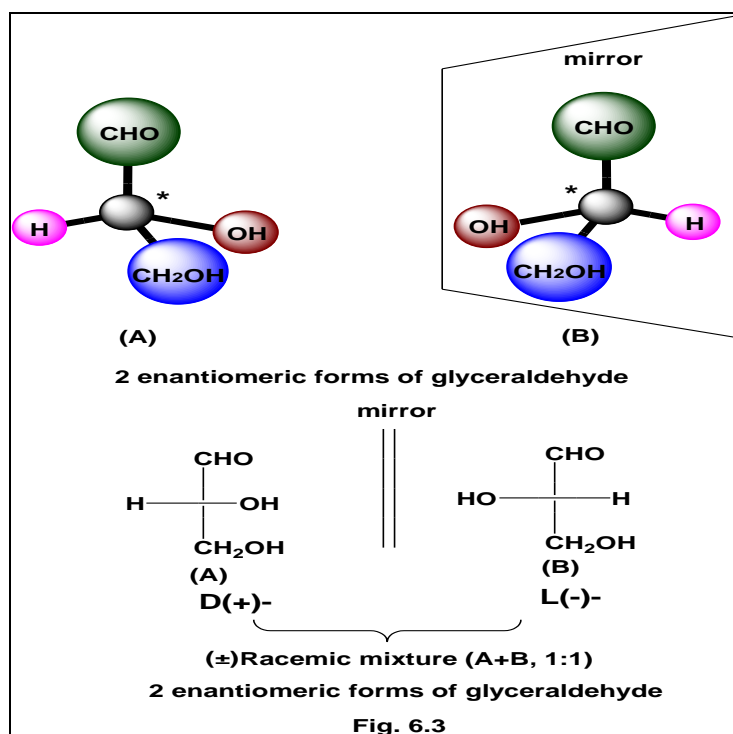

**From figure 6.3 can be concluded that:**

1. Glyceraldehyde exists in two enantiomeric forms (**A**) and (**B**) represented by Fischer projection.
2. An equal amounts of (**A**) and (**B**) forms give racemic mixture symbolic as (\pm).
3. A racemic mixture: is a 50:50 mixture of the 2 enantiomers of a chiral compound.
4. In case of the two glyceraldehyde structures, the structure (**A**) with the (**OH**) group to the right is prefixed by the symbol **D** (Dextro), and the structure (**B**) with the (**OH**) group to the left is prefixed by the symbol **L** (Levo).
5. Clockwise rotation of polarized light is abbreviated to (+), anticlockwise rotation is indicated by the term (-).

B- Compounds with two or more chiral centers:

In general, molecules with **n** different chiral centers exist in 2^n enantiomeric forms, which can be combined in pairs to form that number (2^{n-1}) of racemic mixtures.

Ex: the **4C** sugars with two different chiral centers are exist in 4 enantiomeric forms and as two racemic mixtures. These are known as therose and erythrose (Fig. 6.4).

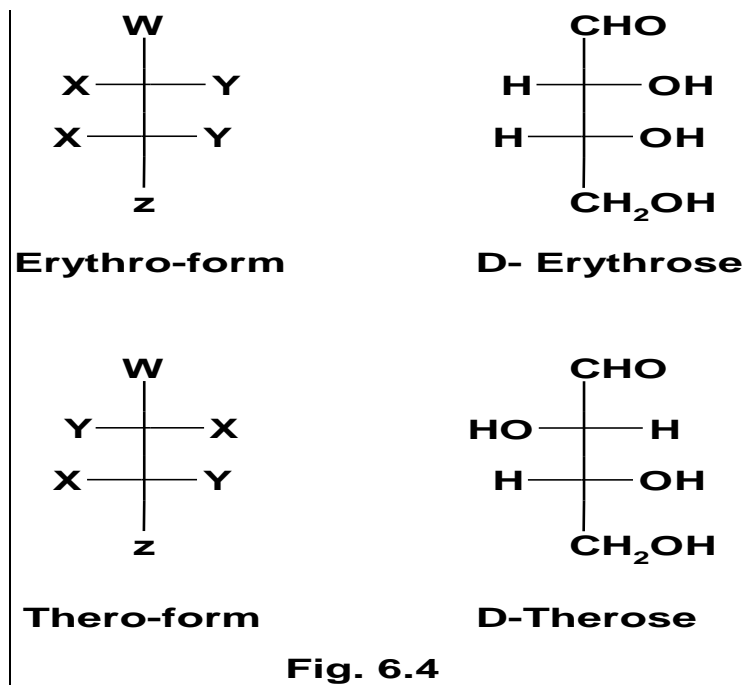

Erythrose exists in two enantiomeric forms (**A** and **B**) as does therose (**C** and **D**) (Fig. 6.5).

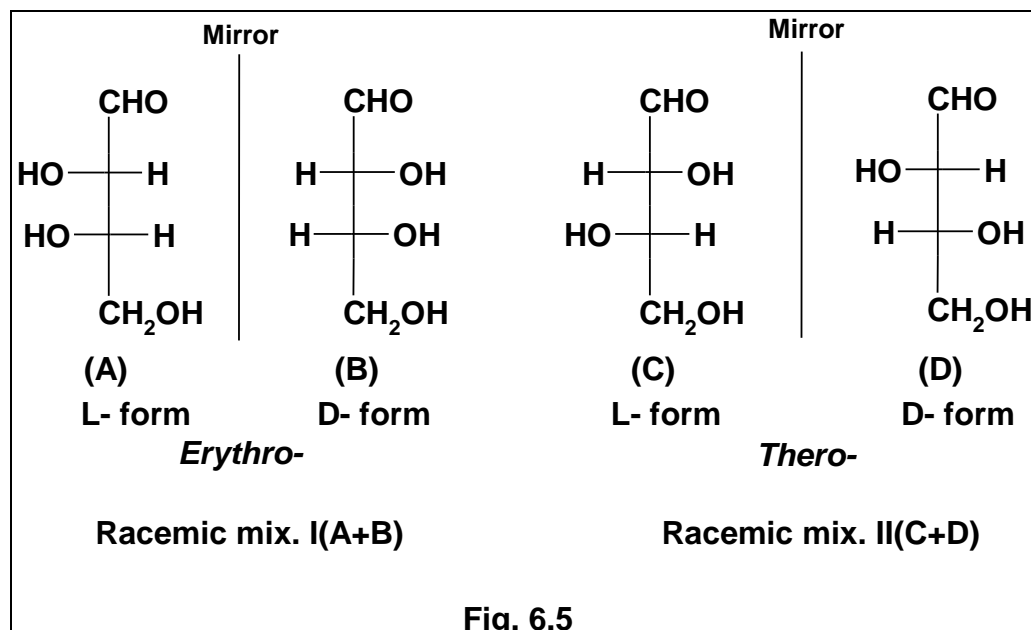

From Fig. 6.5 can be concluded the following:

- Structures (A and B) or (C and D) are enantiomers, while (A and C; A and D) or (B and C; B and D) are diastereoisomers.
- When the two identical or similar groups attached to the two chiral carbons are on the same side, the compound is prefixed by (*erythro*) as in structures (A) and (B), and when the two identical or similar groups are on opposite sides, the compound is prefixed by (*threo*) as in structures (C) and (D).

6.4 Compounds with two identical chiral centers, Meso-form

A molecule that contains two chiral centers but the two ligands attached to one chiral carbon atom are the same as those attached to the second chiral atom exists in only three stereoisomers as in tartaric acid (Fig. 6.6).

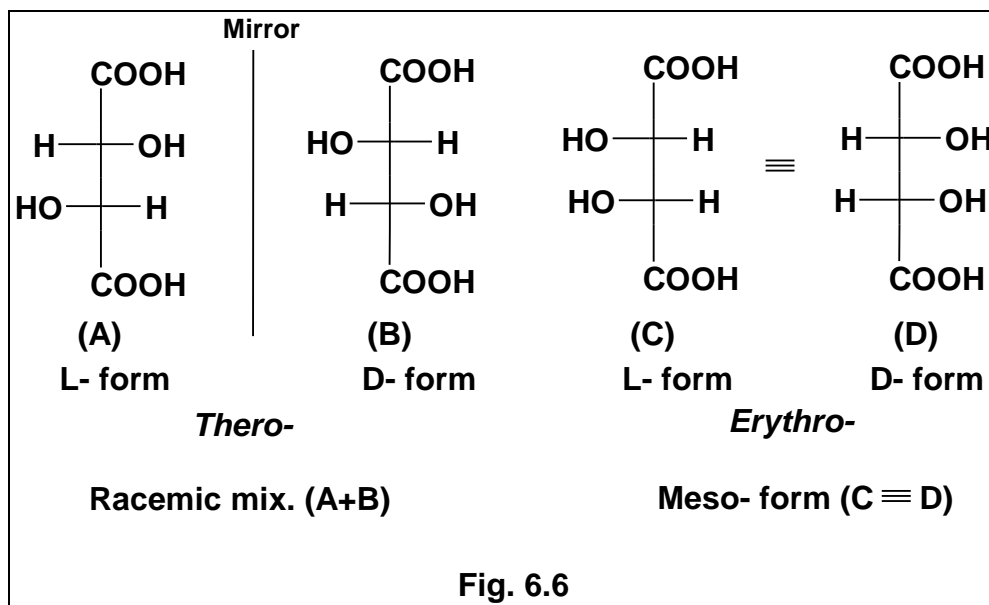
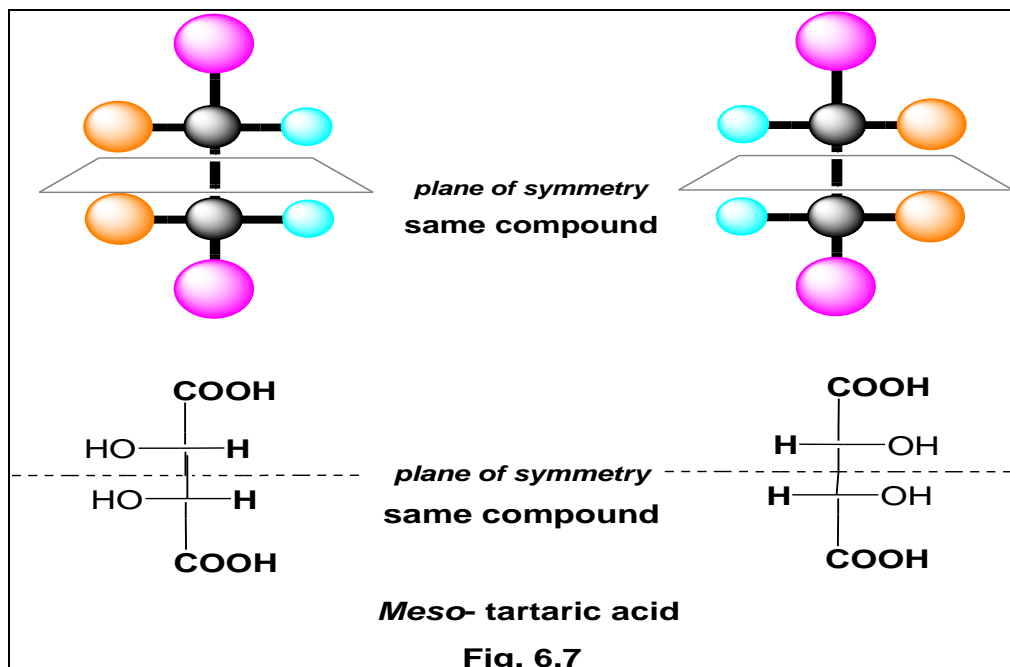

Fig. 6.6

From (Fig. 6.6) can be concluded the following:

- 1- The thero-isomers (**A** and **B**) are enantiomers and the one is the reflection of the other.
- 2- The structures (**C** and **D**) in erythro-form are in fact the same. This stereoisomer is represented correctly by the structure (**C**) or (**D**) and it is not optically active.
- 3- The optically inactive erythro-form is described as (Meso-Form).
- 4- Meso-compound contains a **plane or center of symmetry** dividing the molecule into two identical parts such that one is the reflection of the other (Fig. 6.7).



(R) and (S) system

Cahn, Ingold and Prelog gave a new convention for distinguishing 2 enantiomers from each other. This is called the Rectus (or **R**) and the Sinister (or **S**) system. In this system the



atoms or groups linked to a chiral carbon are assigned priority on the basis of the sequence rules (See page 22).

After ascertaining the priority of the atoms or groups attached to chiral carbon atoms, the isomer is viewed from the side opposite to the group of least priority and the arrangement of the remaining three groups are observed. If the arrangement of the groups (in moving from the top priority group to the second and then the third priority group) is clockwise, then the isomer has **R**-configuration. If this arrangement is anticlockwise, it is assigned **S**-configuration e.g. D-lactic acid has **S**-configuration and L-lactic acid has **R** configuration. It is not necessary that the L isomer is **S**; it can be **S** or **R** (Fig. 6.8).

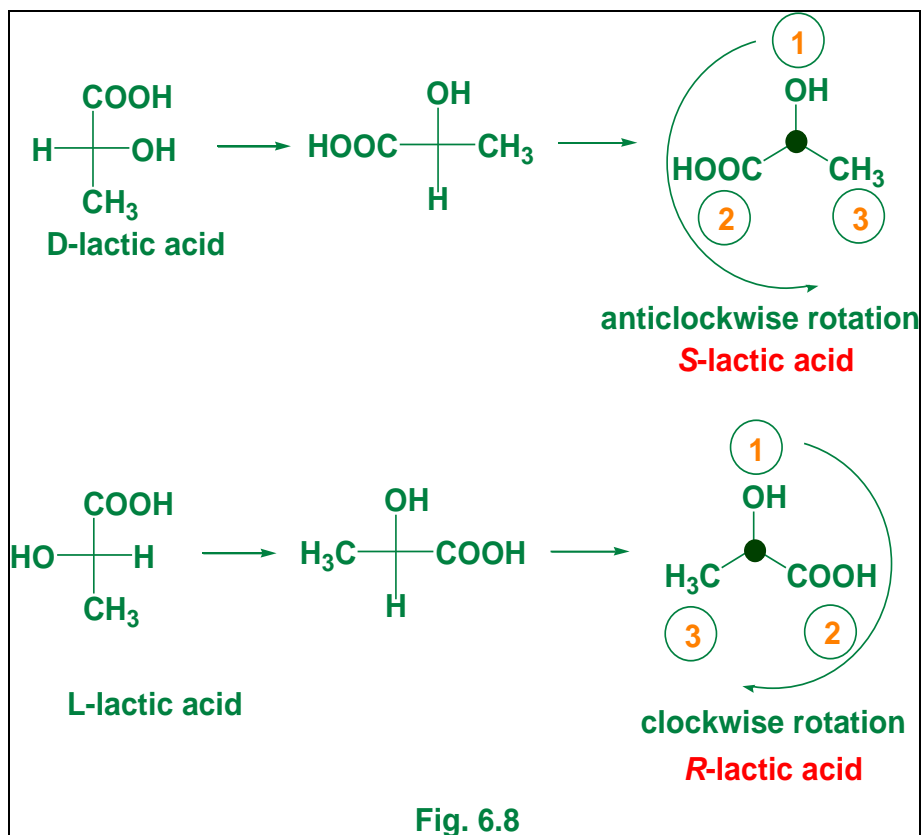

Activities: Assign as R or S-configuration of both Erythro- and Thero-2,3-dihydroxy-butanoic acid.

Summary

- **Optical Activity:** the ability of some compounds to rotate plane polarized light.
- **Chiral carbon atom:** is a carbon atom attached to four different atoms or groups.
- **Achiral:** any molecule that is not chiral.
- **Enantiomers:** stereoisomers that are non superposable mirror images.

- **Diastereomers:** stereoisomers that are not mirror images.
 - **Racemic mixture:** a 1:1 (equimolar) mixture of two enantiomers.
 - **Meso-form:** is optically inactive compound with at least 2 stereocenters that is achiral due to the presence of a plane of symmetry.
 - **Dextrorotatory (+):** an optically active compound that rotates plane polarized light in a clockwise direction.
 - **Levorotatory (-):** an optically active compound that rotates plane polarized light in a counterclockwise direction.
 - **R-configuration:** If the arrangement of the groups (in moving from the top priority group to the low priority group) is clockwise.
 - **S-configuration:** If the arrangement of the groups (in moving from the top priority group to the low priority group) is anticlockwise.
-

Lecture 1

7. Method of stereoselective addition and elimination reactions

A- Use of stereoselective addition reactions.

7.1 Experimental determination of the mode addition.

A reaction, which yields one stereoisomer of several possible stereoisomers, is called a **stereoselective** reaction. Some stereoselective addition reactions will be described such as addition of hydrogen, halogen and hydroxylation.

Simply terms will be used to indicate the stereochemical facts in addition reactions:

- 1- If the two groups may be added to the same side of the alkene double bond, the addition is described as **syn-** or **cis-** addition.
- 2- If the two groups may be added to the opposite sides, the addition is described as **anti-** or **trans-** addition (Scheme 7.1).

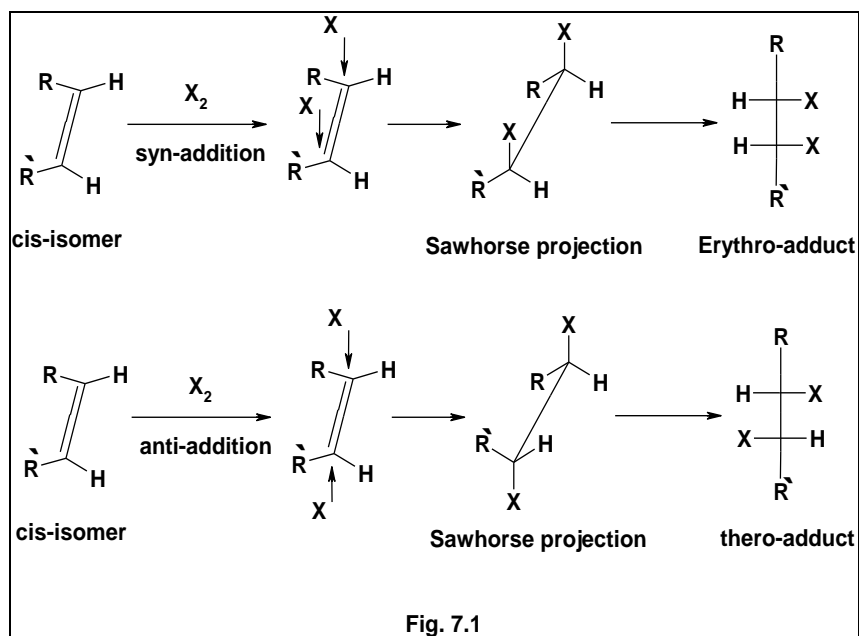

- 1- The above reaction is also stereospecific reaction in which different stereoisomers give stereochemically different products. i. e., the geometrical isomers give optical isomers through the addition reactions.
- 2- In the reaction of the type;

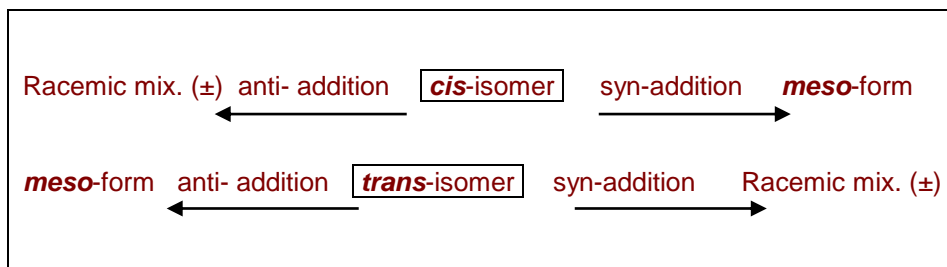

The following examples will be describe the different types of addition reactions:

(i) Hydrogenation:

Catalytic hydrogenation is usually a **syn**-addition (Schemes 7.2 and 7.3).

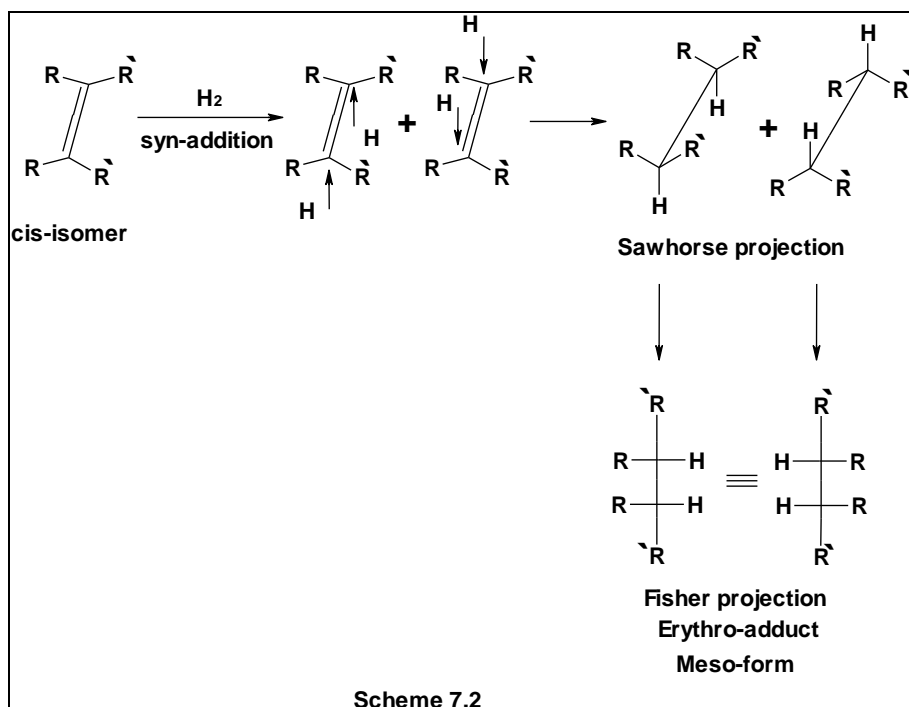

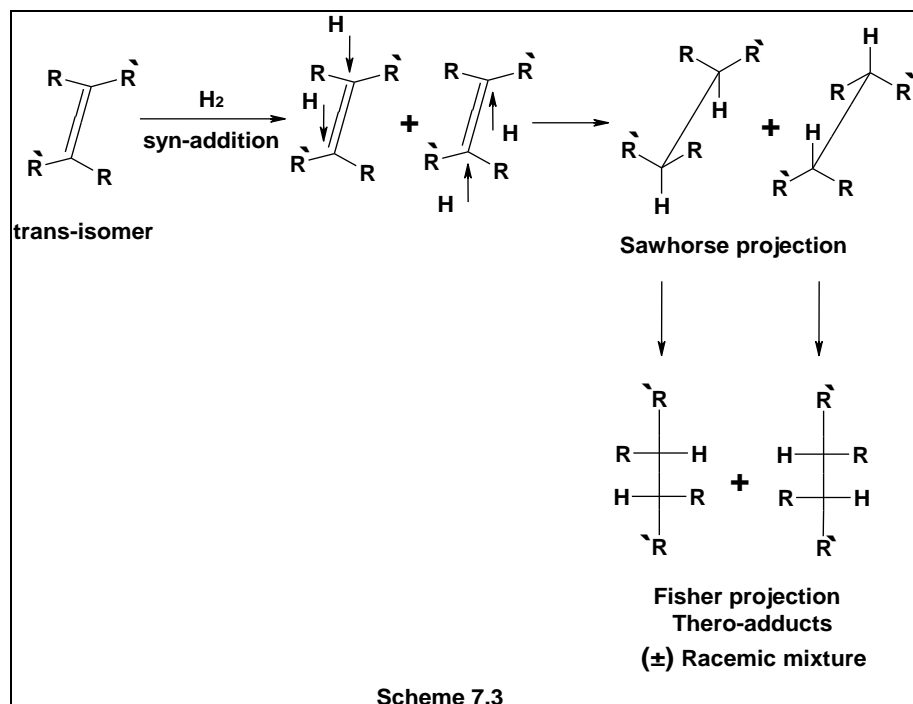

(ii) Halogenation (Bromination):

Bromination is usually an *anti*-addition (Schemes 7.4 and 7.5).

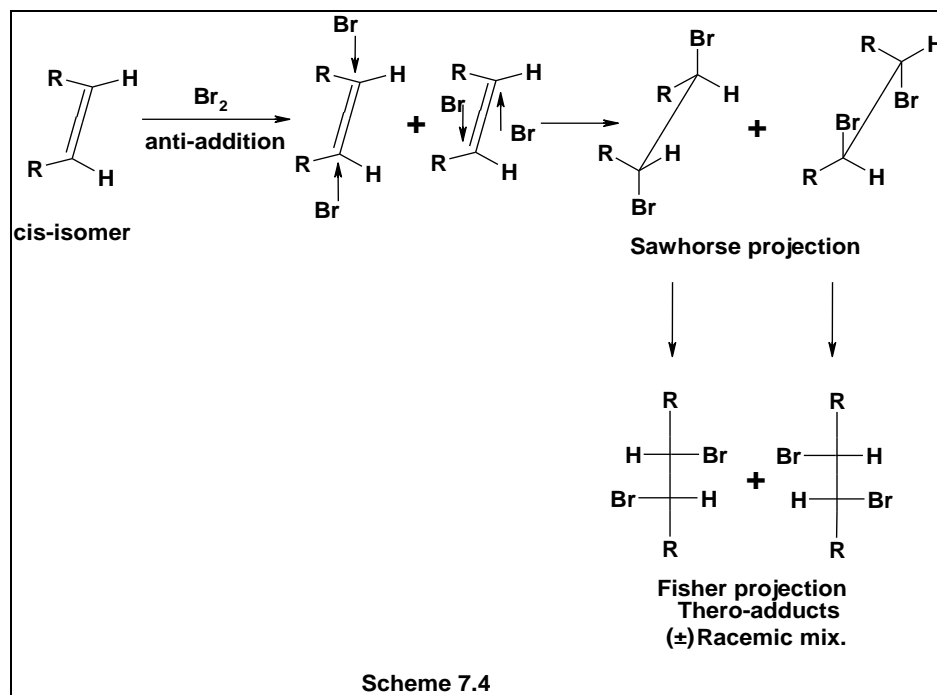

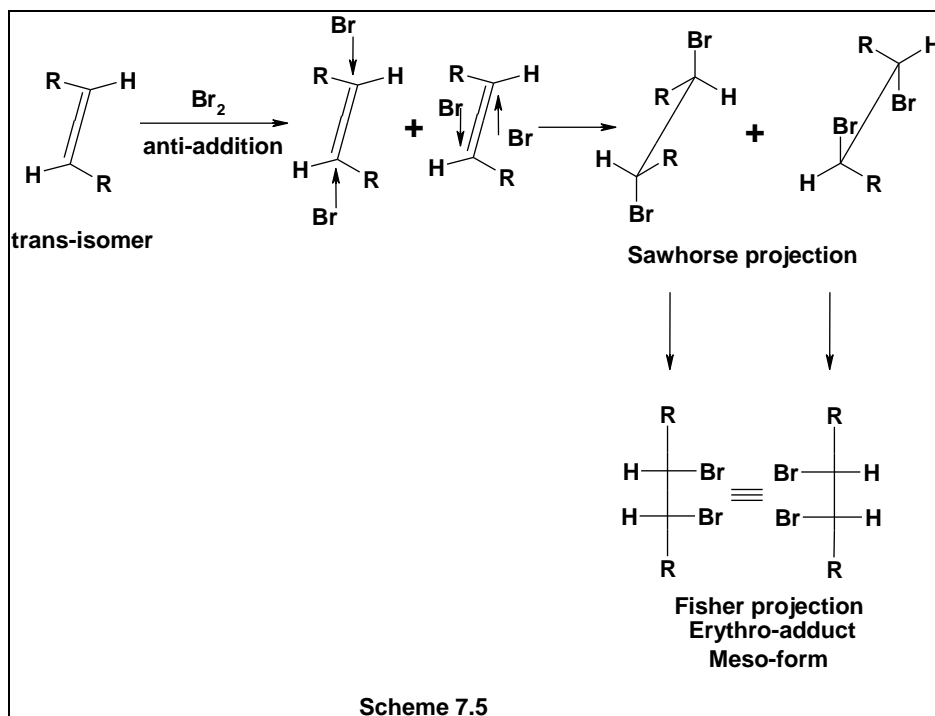

Activities: Consider the bromination reaction formulated below and answer the attached questions:

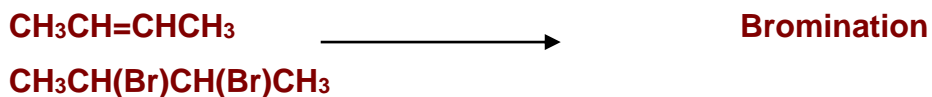

- (i) Formulate the two stereoisomeric alkenes and designate each as *cis* or *trans*.
- (ii) Write through Sawhorse projection the expected enantiomers or a meso-form of the dibromide if the addition was *anti*- or *syn*-.
- (iii) Designe the two enantiomers as *threo* or *erythro*, using Fisher projections.

(iii) Hydroxylation:

Hydroxylation may be *syn*- or *anti*- depending on the choice of reagent.

In summary;

- Hydroxylation with *peracids* is **anti**-addition (Schemes 7.6 and 7.7).

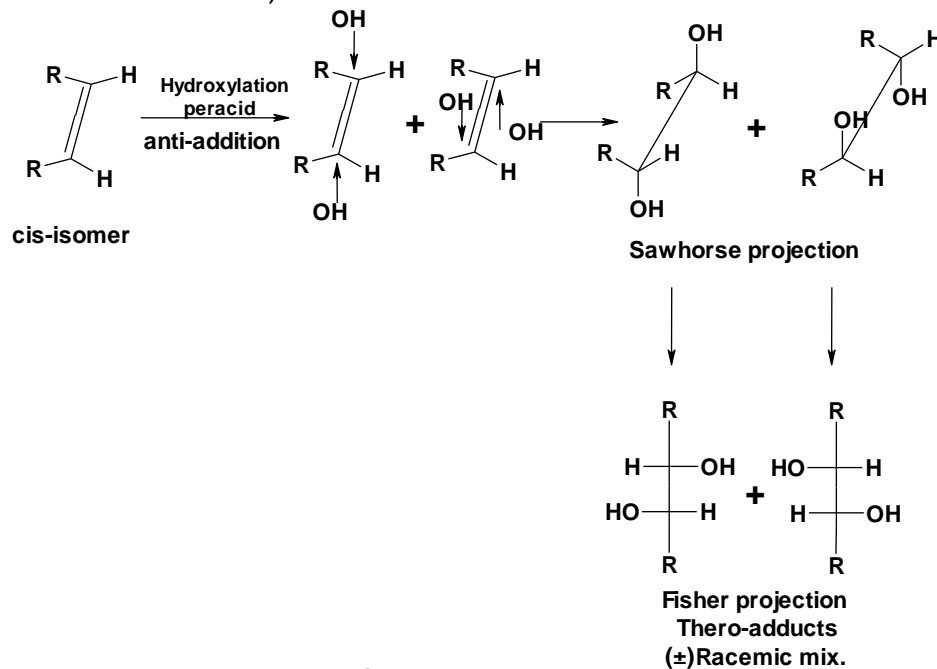

Scheme 7.6

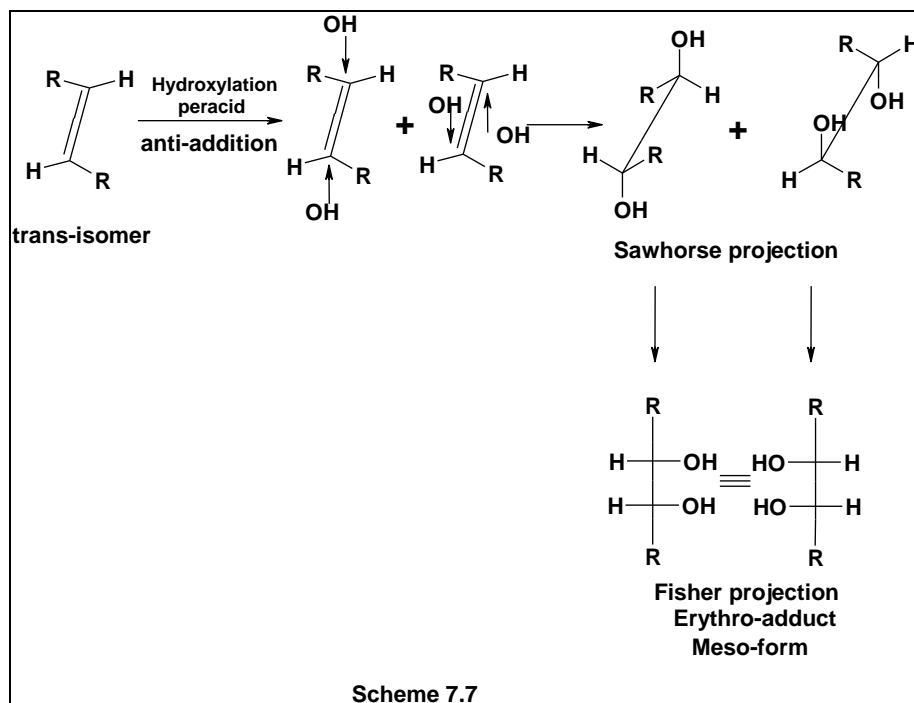

Scheme 7.7

- Hydroxylation with KMnO_4 and OsO_4 is *syn*-addition (Schemes 7.8 and 7.9).

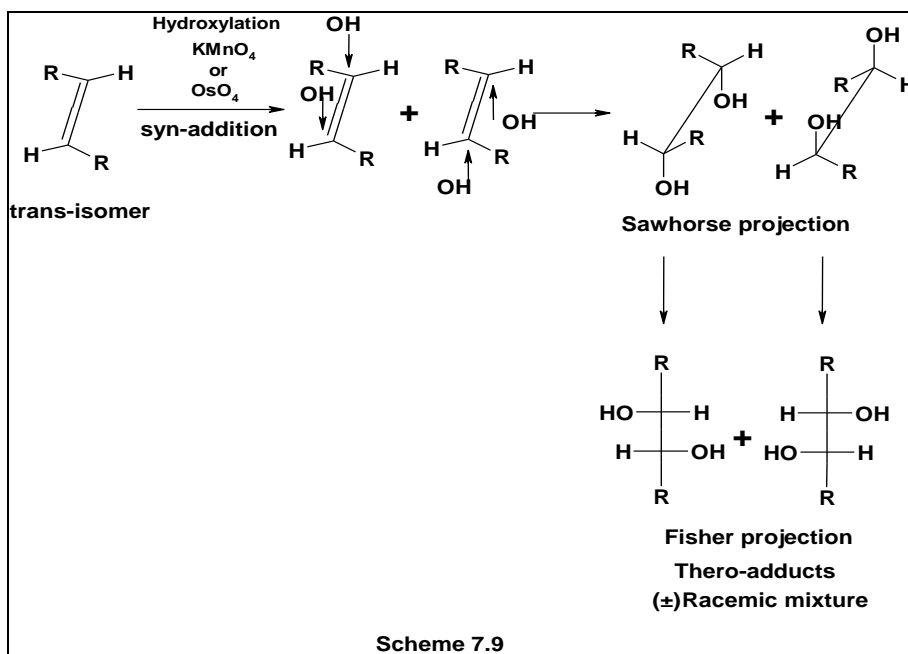
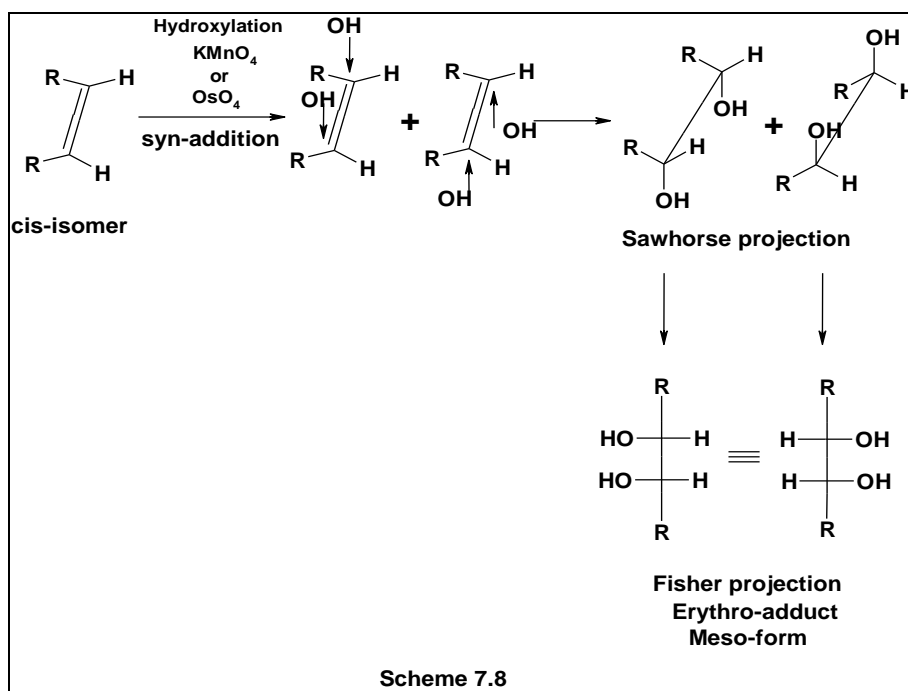

Note that: If alkene used in the addition reactions is unsymmetrical, a racemic mixture of two erythro-adducts will be produced instead of a meso-form in any type of addition.

Ex: Hydroxylation of Z-2-pentene in presence of OsO₄ (Scheme 7.10).

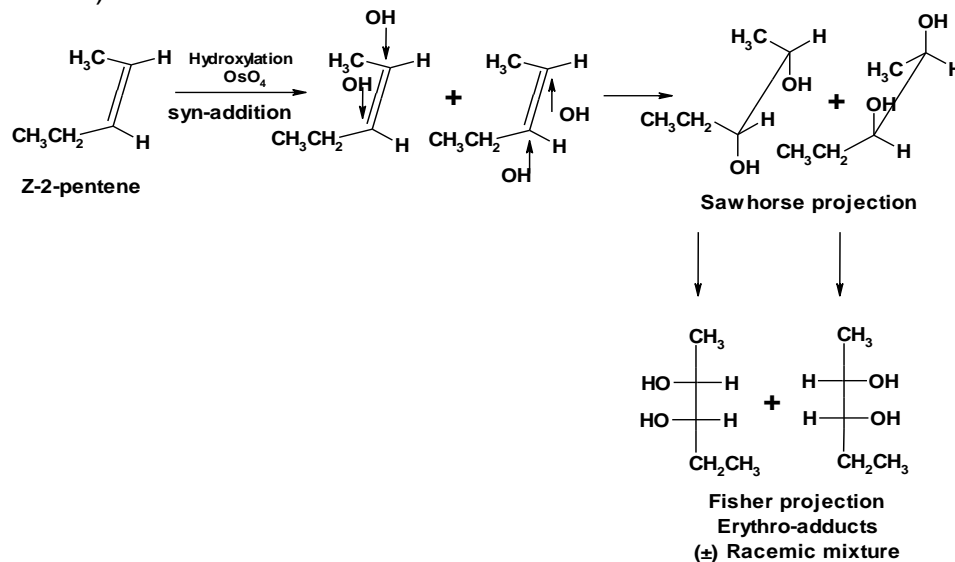

Scheme 7.10

7.2 Application of stereospecific addition for determination of configuration

The geometrical isomers are subjected to the same stereospecific reaction and the nature of the products investigated.

If the addition was *anti*-addition, the alkene-isomer which gives a **racemic** mixture (\pm), it would be **cis**-isomer, and the alkene-isomer which gives a **meso**-product, it would be the **trans**-isomer, and *vice-versa* when the addition was *syn*-addition.



Summary

- **Stereoselective reaction:** a reaction, which yields one stereoisomer of several possible stereoisomers.
- **Stereospecific reaction:** a reaction in which different stereoisomers give stereochemically different products.
- **Catalytic hydrogenation:** is usually a **syn**-addition.
- **Bromination:** is usually an **anti**-addition.
- **Hydroxylation:** may be **syn**- or **anti**- depending on the choice of reagent.
- **Hydroxylation:** with *peracids* is **anti**-addition.
- **Hydroxylation:** with KMnO_4 and OsO_4 is **syn**-addition.

Lecture 8

8- Use of stereoselective elimination reactions

Elimination reactions such as dehydration, dehydrohalogenation and dehalogenation are important for the preparation of alkenes and alkynes. Since both substrate and product may be capable of existing in stereoisomeric forms. In many respects the stereochemistry of elimination processes is the reverse of the stereochemistry of addition process.

8.1 Experimental determination of the mode elimination

Elimination reactions are also, stereospecific. There are two types of elimination, unimolecular (E_1) and bimolecular (E_2), the later is common and it will be discussed. In fact The preference mode of elimination is the *anti*-elimination.

Anti-elimination of two atoms or groups from adjacent carbon atoms requires an antiperiplanar arrangement (trans to each other) of the two groups which are to be removed, the mechanism of E_2 elimination is shown in example below (Scheme. 8.1).

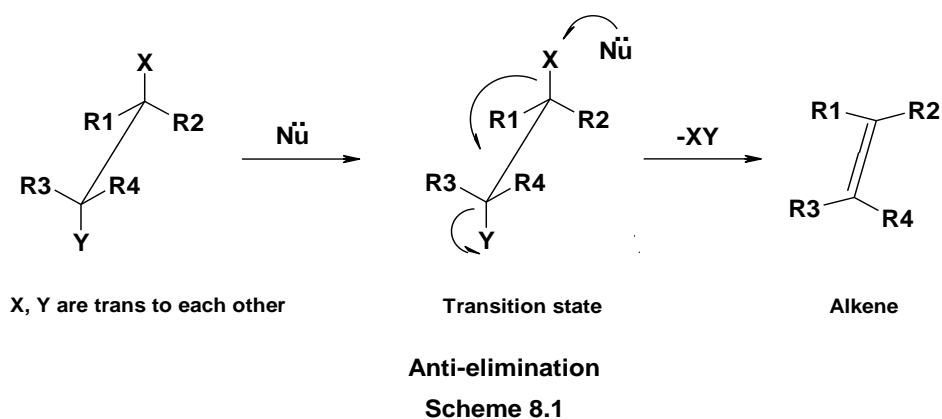

In the reaction of the type ;

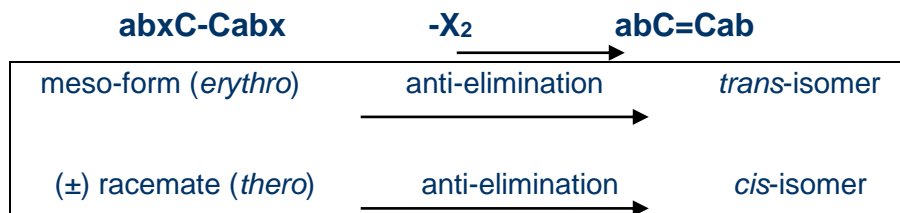

The following example of anti-elimination will be reviewed briefly:

8.2 Dehalogenation (Debromination)

Dehalogenation— most often of dibromides- by reaction with zinc or with sodium iodide is very useful process, the reaction with iodide ion is more highly stereospecific.

The *thoro*-dibromides furnish **cis**-alkenes and the *erythro*-dibromides give **trans**-alkenes as shown in (Scheme 8.2).

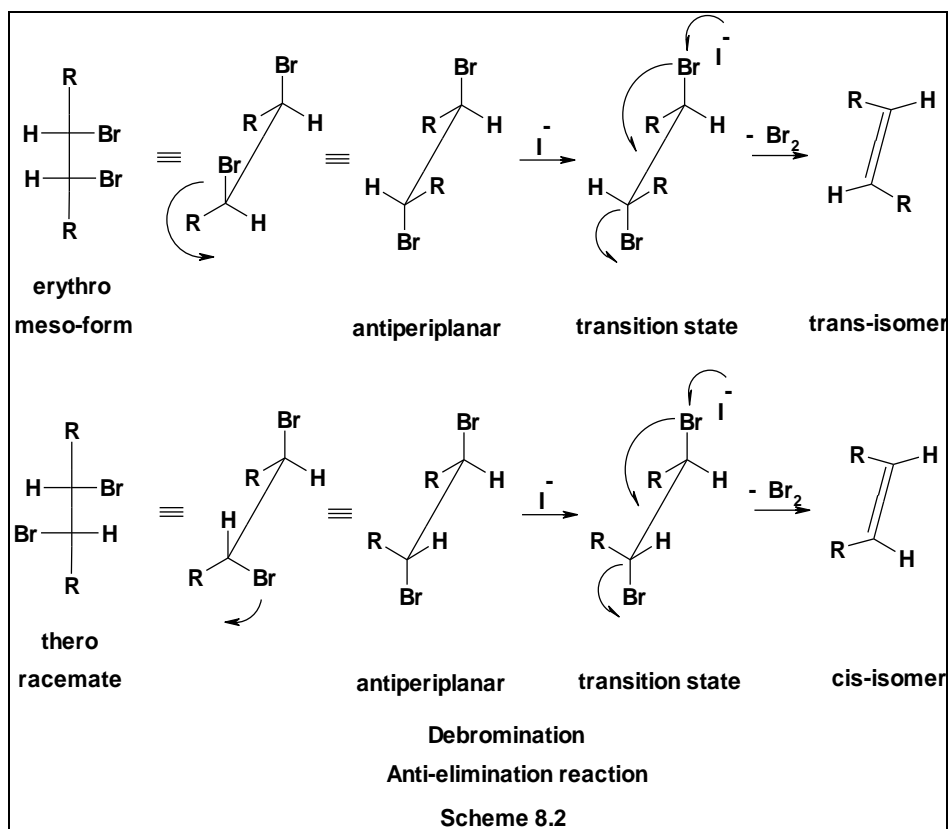

8.3 Dehydrobromination

Dehydrobromination is an **anti-elimination** effected by base, for example, in the conversion of dibromides to alkynes. The bromination-dehydrobromination reaction may be written as shown in (Scheme 8.3):

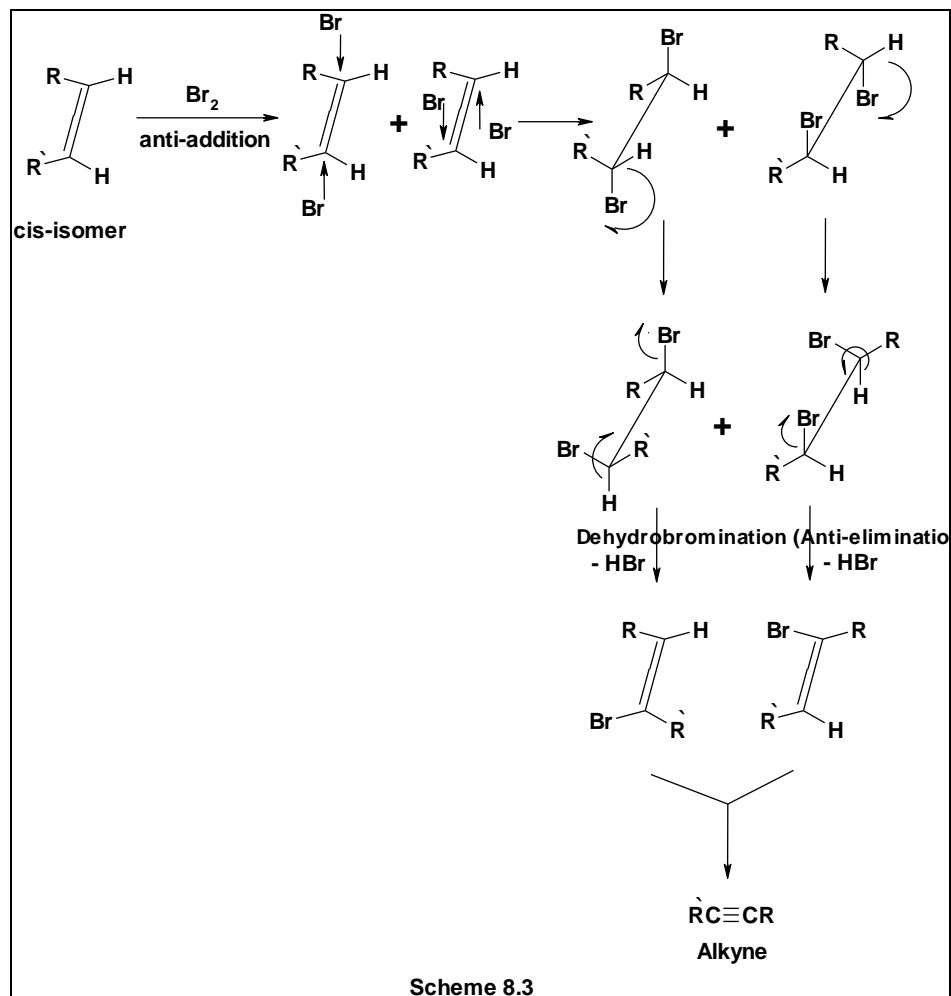

There is only one alkyne but two stereoisomeric vinyl bromides (Scheme. 8.3). The conclusions are that *cis*-alkenes yield alkynes via *threo*-dibromides but that *trans*-alkenes do not.

The *erythro*-dibromides formed from *trans*-alkenes usually give a mixture of two vinyl halides (Scheme. 8.4).

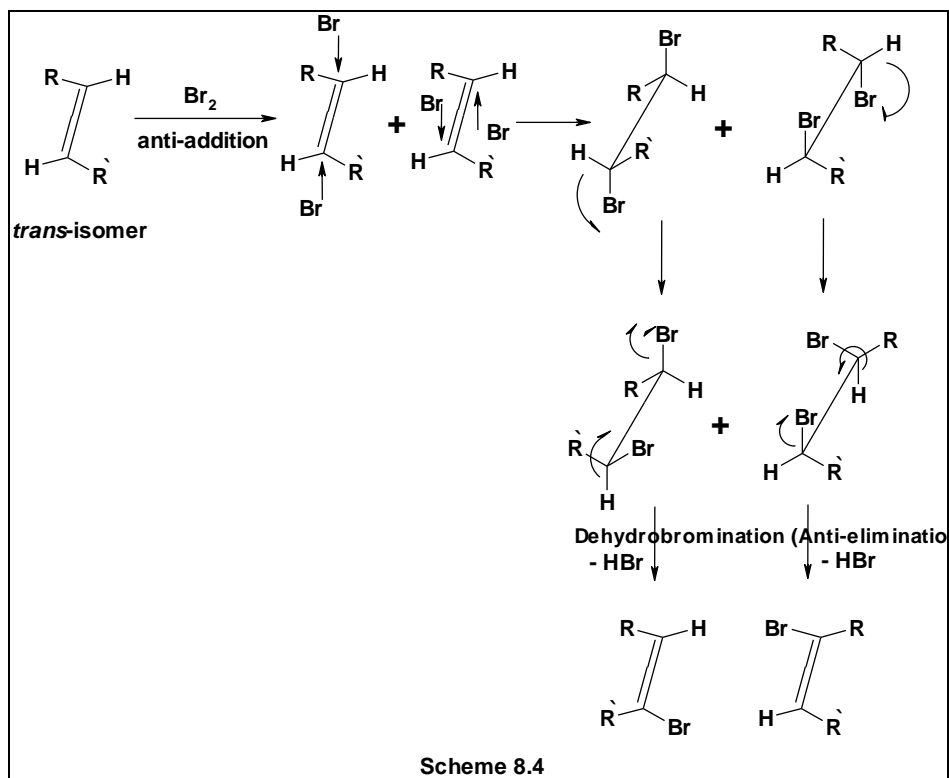

Activities: 2-butene-4-ol may be brominated and the resulting dibromide reconverted to 2-butene-4-ol, thus:



Given that both bromination and occur in an *anti*-manner, use Sawhorse projections to discover whether *trans*-2-butene-4-ol gives the *cis*- or *trans*-isomer as a result of these addition and elimination reactions.



Summary

- There are two types of elimination, unimolecular (E_1) and bimolecular (E_2), the later is common.
- The preference mode of elimination is the anti-elimination.
- The *thero*-dibromides furnish ***cis***-alkenes and the *erythro*-dibromides give ***trans***-alkenes.
- The *cis*-alkenes yield alkynes via *thero*-dibromides.
- The *trans*-alkenes usually give a mixture of two vinyl halides.

Lecture 9

9. Conformations of alkanes

The rotational symmetry of a σ bond (a carbon-carbon single bond) allows the atoms or groups of atoms connected by that bond to rotate it. As a result of this kind of rotation, many molecules assume several different shapes. These shapes called conformations (Rotamers) which are not isolated.

Some conformations are more stable than others. The term "conformation" is used to denote any one of the infinite number of momentary arrangements of the atoms in space that result from rotation about single bonds.

9.1 Conformations of acyclic compounds

A- Conformations of ethane

Some conformations of a simple molecule like **ethane** may be represented by several Sawhorse or Newman projections (Fig. 9.1), because the possibility of free rotation about single carbon-carbon bond.

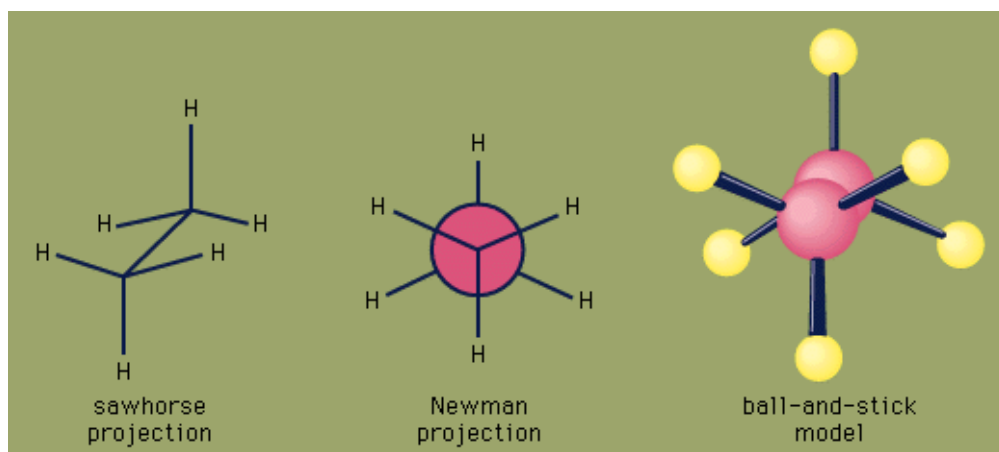
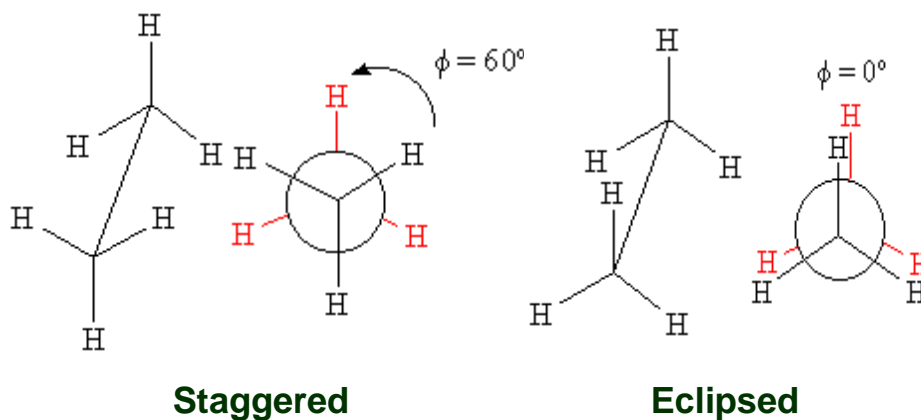

Fig. 9.1

If this bond is rotated in 1° intervals to 360° , a six conformers are produced, three of them are the same and said to be staggered and the other three also identical and said to be eclipsed, this is due to the symmetry of this molecule (Fig. 9.2).



Sawhorse and Newman projections of ethane molecule

Fig. 9.2

The term staggered is used when two atoms or groups attached to two adjacent carbon atoms are as far away from each other, and the term eclipsed is used when the two atoms or groups one of them is on the front of the other (Fig. 9.3).

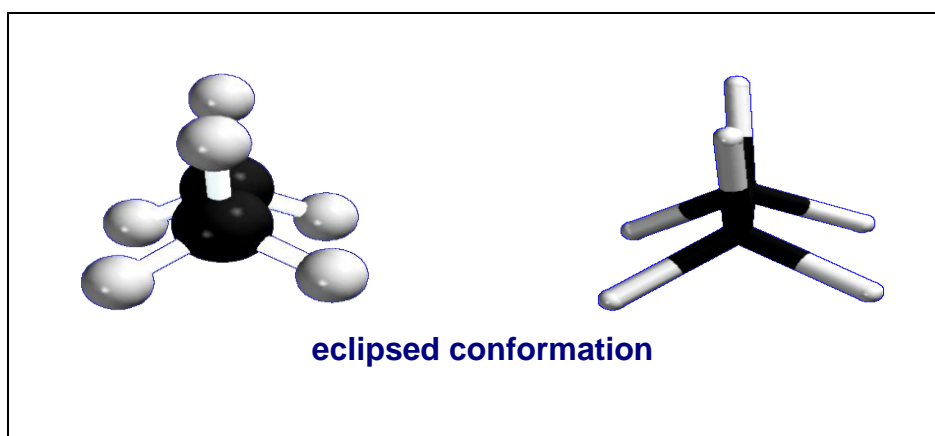

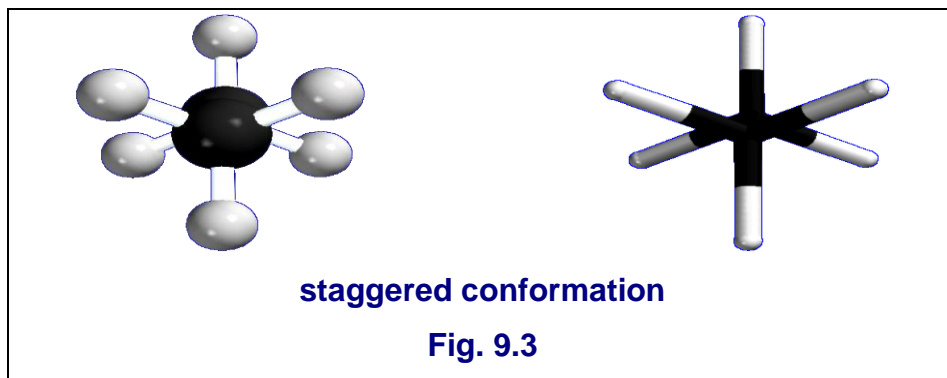

When the hydrogen atoms are eclipsed the angles between the atoms attached to the front and rear carbon atoms (the torsional angle) are zero. When the hydrogen atoms are staggered the torsional angle is 60° .

The eclipsed conformation of ethane is (12 kJ/mol) less stable than the staggered. This is due to the eclipsed conformation is destabilized by torsional strain.

Torsional strain : is the strain that results from eclipsed bonds. The relative energies of these conformers of ethane are shown in (Fig. 9.4).

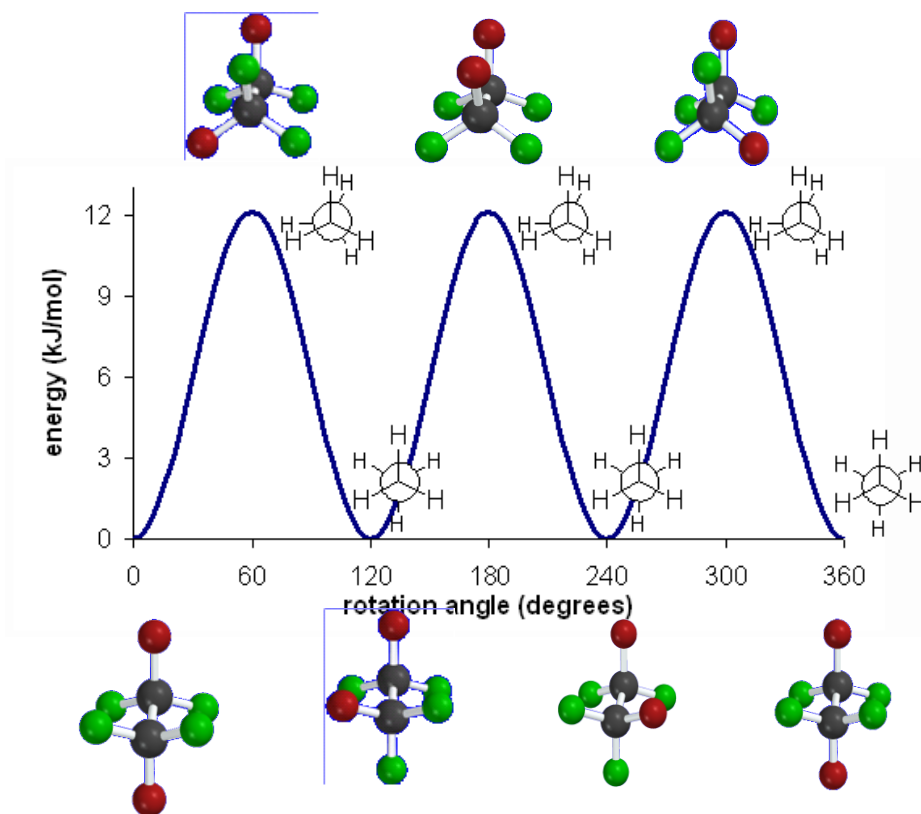
**Fig. 9.4**

Among the various conformations of ethane, the staggered conformations are lower in energy and most stable than eclipsed conformations.

B- Conformations of butane

Molecules less symmetrical than ethane can be written in additional conformations, butane, for example.

In butane the two methyl groups are used for reference, there may exist in two eclipsed conformers (eclipsed and fully eclipsed (*cisoid*)), and two staggered conformers (gauche-staggered and anti-staggered (*transoid*)), that is according to the two methyl groups as shown in (Fig. 9.5).

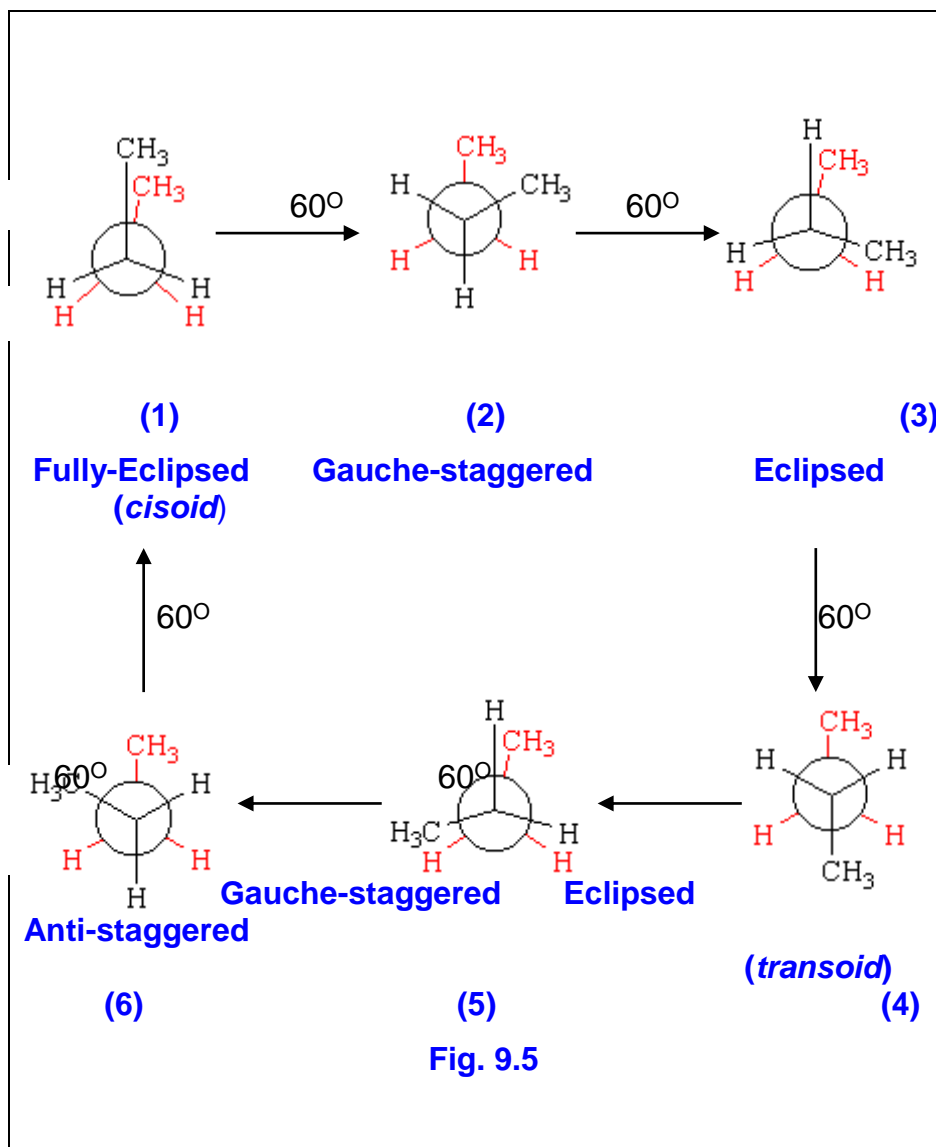

The energy diagram for the different conformations of butane is shown in (Fig. 9.6).

Notice in the next figure that, the staggered conformations of butane do not have the same energy level, nor do all the eclipsed conformations have the same energy level.

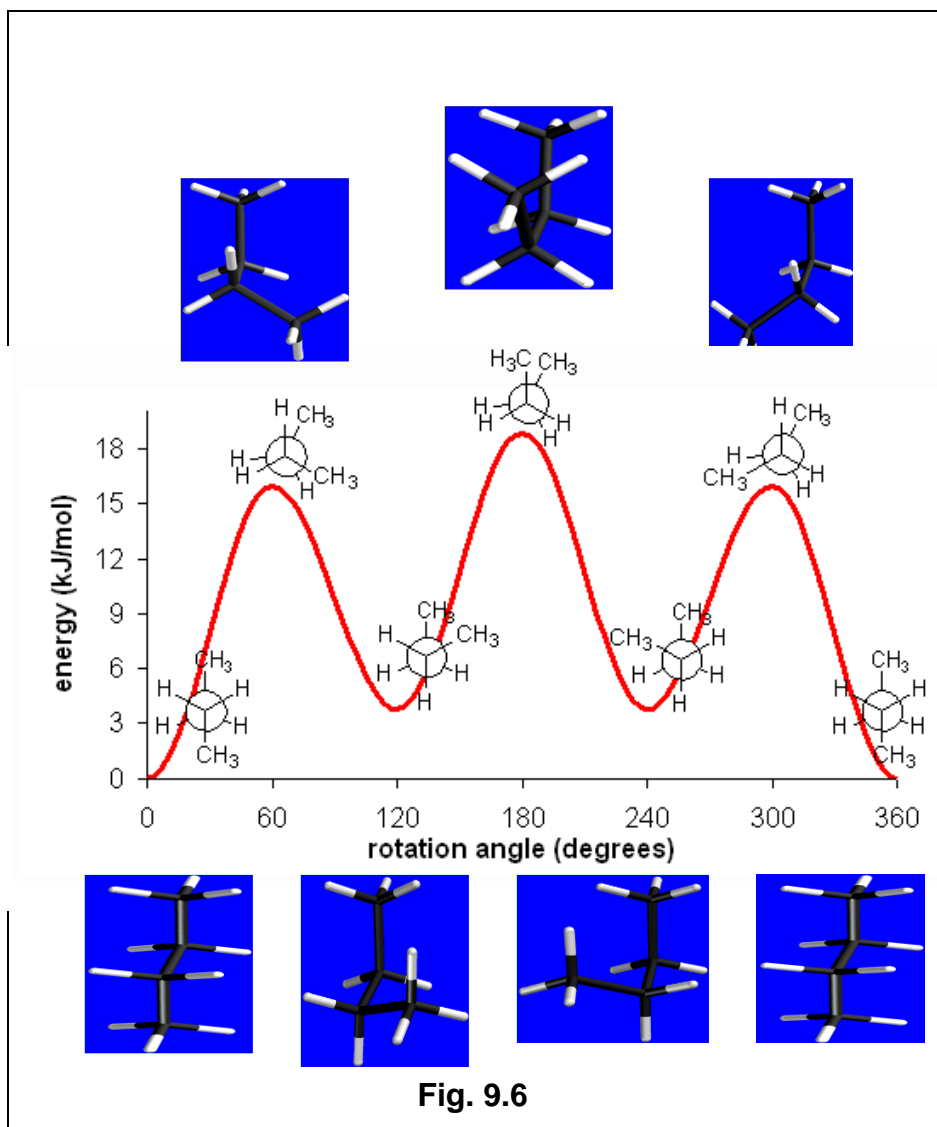

So, it can be arrange the different conformations of butane according to the energy and the stability of each conformer to the other as the following:

Fully-eclipsed (*cisoid*) > eclipsed > gauche-staggered > anti-staggered (*transoid*).

← **Energy** →

Fully-eclipsed (*cisoid*) < eclipsed < gauche-staggered < anti-staggered (*transoid*).

Stability 

Activities: Describe the rotation using Newman projections between the different conformers produced from each of the following compounds:

- i- $\text{CH}_3\text{CH}_2\text{CH}_2\text{Cl}$.
- ii- $\text{PhCH}_2\text{CH}_2\text{CH}_3$.
- iii- $\text{CH}_3(\text{Cl})\text{CH}_2\text{CH}_2(\text{Cl})\text{CH}_3$.

The two gauche-conformers (2) and (6) (Fig. 9.5) are equal in energy and are not identical molecules, each one of them is a mirror image to the other. So, they are conformational enantiomers (Fig. 9.7).

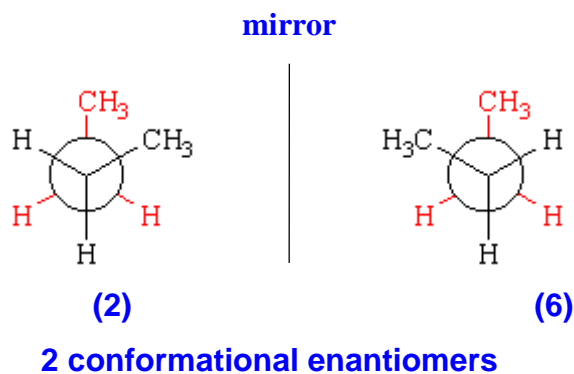

Fig. 9.7



Summary

- **Conformations:** are different spatial arrangements of a molecule that are generated by rotation about single bonds.
- **Conformations of ethane:** has six conformers, three of them are identical and said to be staggered and the other three also identical and said to be eclipsed.
- **Conformations of butane:** butane exists in two eclipsed conformers (eclipsed and fully eclipsed (***cisoid***)), and two staggered conformers (gauche-staggered and anti-staggered (***transoid***)), and the two gauche-staggered conformers are conformational enantiomers.
- The staggered conformations are lower in energy and most stable than eclipsed conformations.

Lecture 10

10. Conformations of cycloalkanes

10.1 Introduction

The pattern of optical isomerism exhibited by alicyclic compounds is similar to that of aliphatic compounds, the main difference between the two is that in alicyclic compounds, rotation about **C-C** single bonds constituting the ring is restricted to the extent, that makes possible the existence of geometrical (cis- trans) isomerism, i. e., in alicyclic compounds geometrical isomerism is exhibited as well as optical isomerism.

10.2 Geometrical shape of the rings

A- Cyclohexane

If the cyclohexane ring was flat, all the hydrogen atoms on the ring carbons would be eclipsed. So, the planar conformation is destabilized by torsional strain, but in puckered conformation (Fig. 10.1) that all the hydrogen atoms are staggered and the energy of this puckered conformer is lower than the energy of flat cyclohexane, due to the more-favorable sp^3 bond angle and fewer hydrogen-hydrogen repulsions.

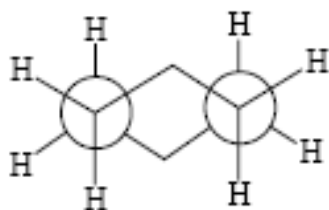

Newman projection
of the chair-form of cyclohexane

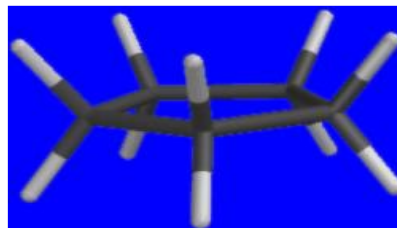

Planar conformation of cyclohexane

Fig. 10.1

What of the other cyclic compounds?

B- Cyclopentane has near-optimal bond angle ($109^{\circ}28'$) if it was flat, but cyclopentane also is slightly puckered, so that the hydrogen atoms attached to the ring carbons are staggered as in envelop and half-chair conformers. Envelope and half-chair are of similar stability and interconvert rapidly. (Fig. 10.2).

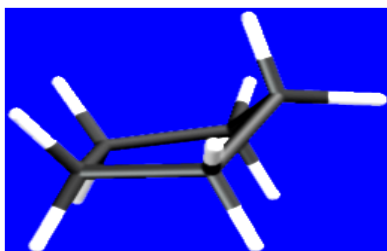

Envelop-form

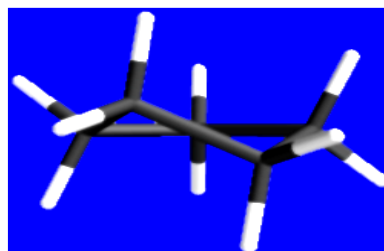

Half-chair-form

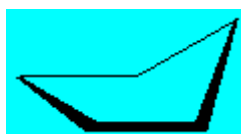

Envelop-form

Fig. 10.2

C- Cyclobutane (flat bond angles will be $= 90^{\circ}$) also puckered, even through the puckered causes more-strained bond angles (Fig. 10.3).

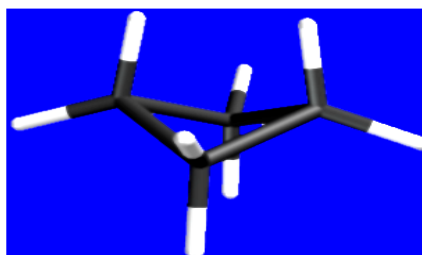
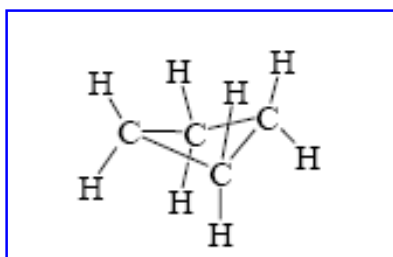

Cyclobutane

Fig. 10.3

Activities: Try to draw the Newman projection of the puckered shapes of cyclobutane, cyclopentane and cyclohexane, then explain the relationship between the hydrogen atoms (i.e. Staggered, gauche or eclipsed).

D- Cyclopropane: must be planar; geometrically, three carbons define a plane. The hydrogen atoms in cyclopropane necessarily are eclipsed (Fig. 10.4).

On the other hand, according to the modern conceptions, the σ bonds in cyclopropane differ from ordinary σ bonds and their hybridization is different from ordinary sp^3 hybridization, in fact, occupy an intermediate position between the ordinary σ - and π -bonds. These bonds are known as "**banana-bond**" (Fig. 10.4). Now, the angle between the bonds in cyclopropane is 106° instead of 60° according to the classical conceptions, and the bond **H-C-H** angle is about $\sim 120^\circ$.

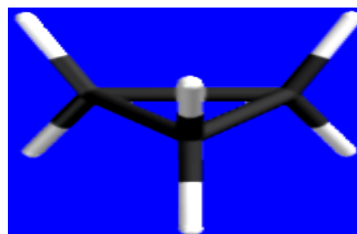
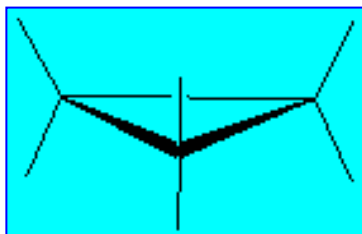

cyclopropane molecule

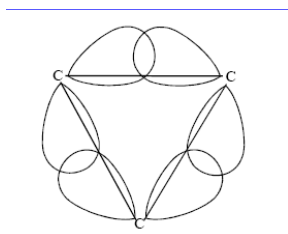

Banana bond of cyclopropane

Fig. 10.4



Summary

- **Cyclohexane:** exists in a chair-form in which all the hydrogen atoms are staggered and the energy of this puckered conformer is lower than the energy of flat cyclohexane.
- **Cyclopentane:** has near-optimal bond angle ($109^{\circ}28'$) and also is slightly puckered, the hydrogen atoms attached to the ring carbons are staggered as in envelop and half-chair conformers.
- **Cyclobutane:** also puckered, the puckered causes more-strained bond angles.
- **Cyclopropane:** the bond in it named "Banana-Bond".
- **Banana-Bond:** is a bond occupy an intermediate position between the ordinary σ - and π -bonds.

Lecture 11

11. Stereochemistry of cyclopropane derivatives

11.1 Molecules with one chiral carbon atom

When a substituted cyclopropane as in (Fig. 11.1) has one chiral carbon atom (C^*), it can exist in two optically active enantiomers (**Ia** and **Ib**) and one racemic mixture, e. g., 2,2-dimethylcyclopropane carboxylic acid (Fig. 11.1).

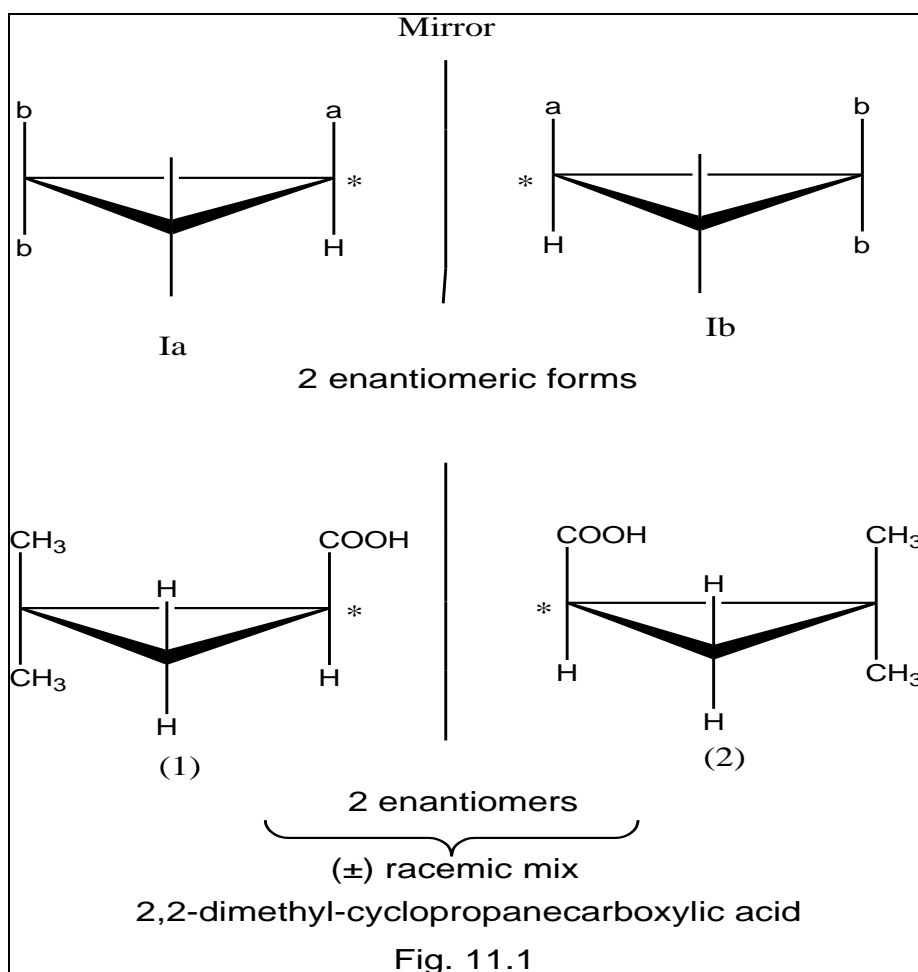

In the above example, there are two enantiomeric forms (**1** and **2**), and one racemic mixture (\pm).

11.2 Molecules with two chiral carbon atoms

a- Two different chiral atoms

If cyclopropane ring has two different substituents, there are two enantiomeric pairs (**IIa, IIb** and **IIc, IId**) and two racemic mixtures (\pm) (Fig. 11.2). In addition to that, two geometrical isomers *cis*- and *trans*-, e. g., 2-methyl-cyclopropanecarboxylic acid (Fig. 11.2).

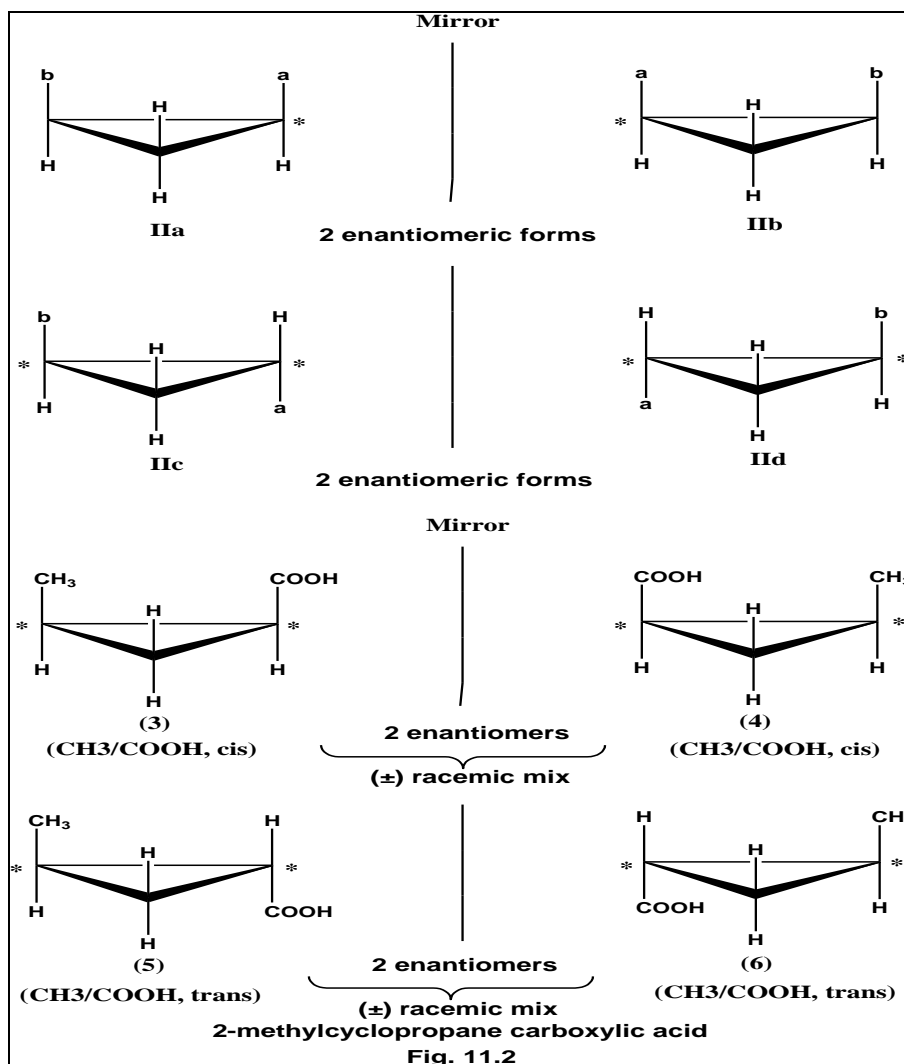

From the above example (Fig. 11.2), there are the following;

- (i) Two enantiomeric pairs (**3, 4** and **5, 6**).
- (ii) Two racemic mixtures (\pm).
- (iii) Two geometrical isomers [(**CH₃/ COOH, cis**) and (**CH₃/ COOH, trans**)].

b- Two similar chiral carbon atoms

When the two substituents of cyclopropane are the same, there are a pair of enantiomers and a meso-form (Fig. 11.3).

The *cis*-isomer has a plane of symmetry and is there for optically inactive meso-form (**IIIa**), the *trans*-isomer exists in two optically active enantiomers (**IIIb** and **IIIc**) combine together to form one racemic mixture (\pm), e. g., cyclopropane-1,2-dicarboxylic acid (Fig. 11.3).

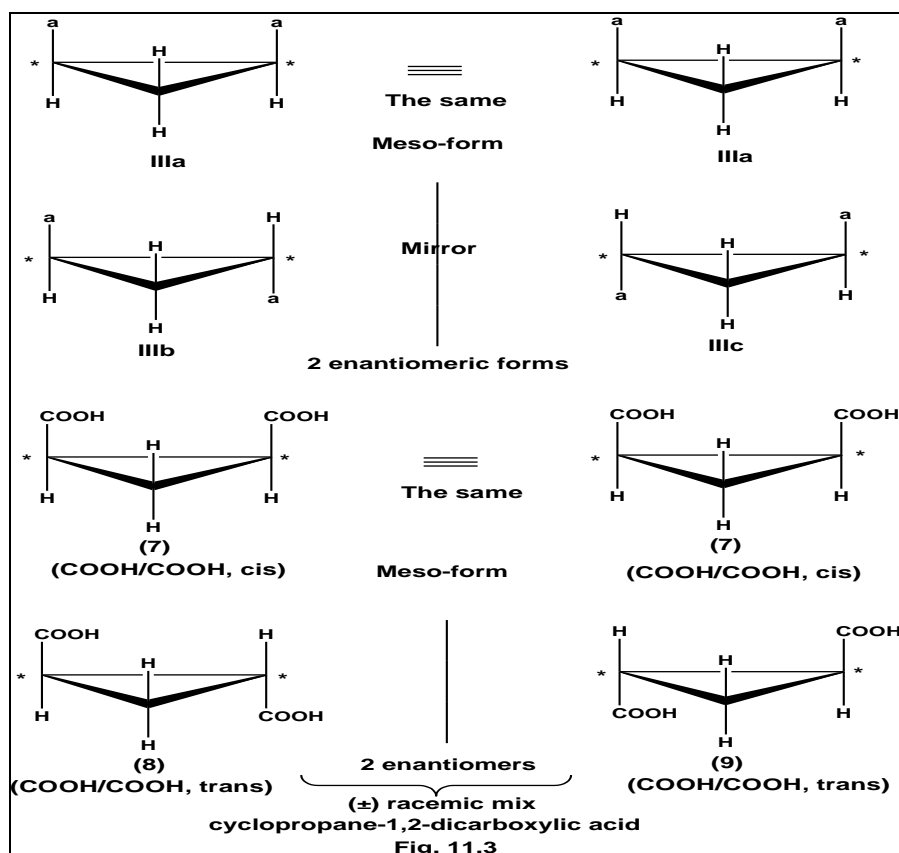



From the example in (Fig. 11.3), there are the following;

- (i) Pair of enantiomers (**8** and **9**).
- (ii) (\pm) Racemic mixture.
- (iii) Meso-form (**7**).
- (iv) Two geometrical isomers [(**COOH/ COOH, cis**) and (**COOH/ COOH, trans**)].

Activities: Find the possible geometrical and optical isomers for each of 1,2-dihydroxycyclopropane.

11.3 Molecules with three different chiral carbon atoms

When 3 chiral carbon atoms in cyclopropane, there are ($2^n=2^3=8$) optically active isomers, i. e., 4 pairs of enantiomers (**IVa, IVb; Va, Vb; VIa, VIb** and **VIIa, VIIb**) (Fig. 11.4), and 4 racemic mixtures (\pm). In addition to 4 geometrical isomers.

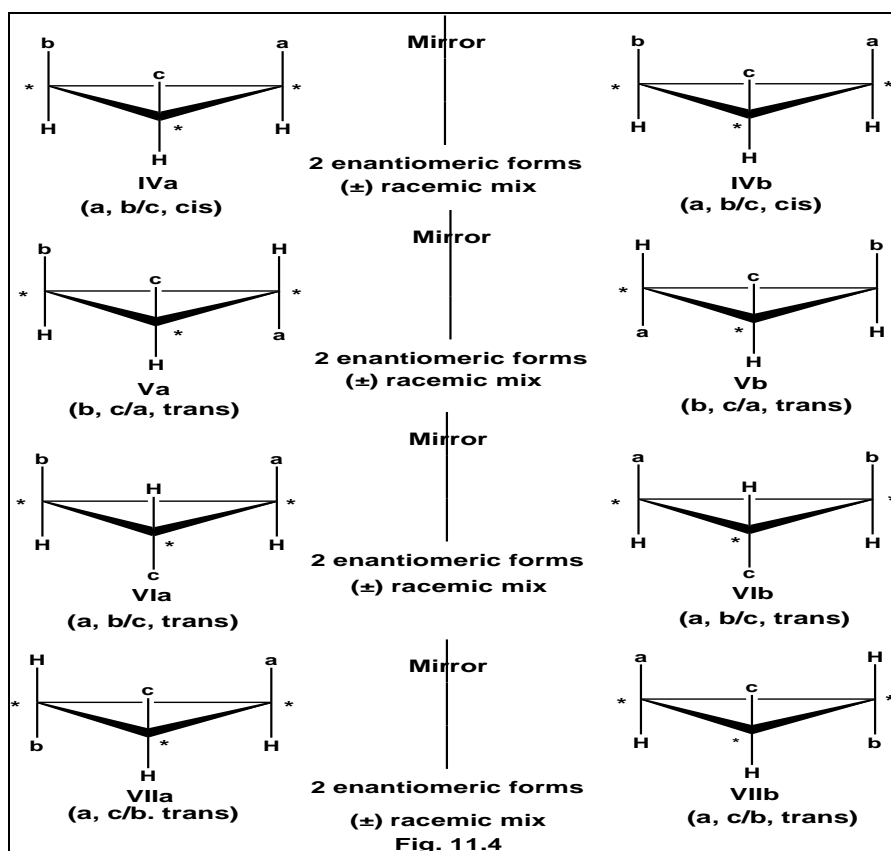



Ex: 2-chloro-3-methyl-cyclopropanecarboxylic acid (Fig. 11.5).

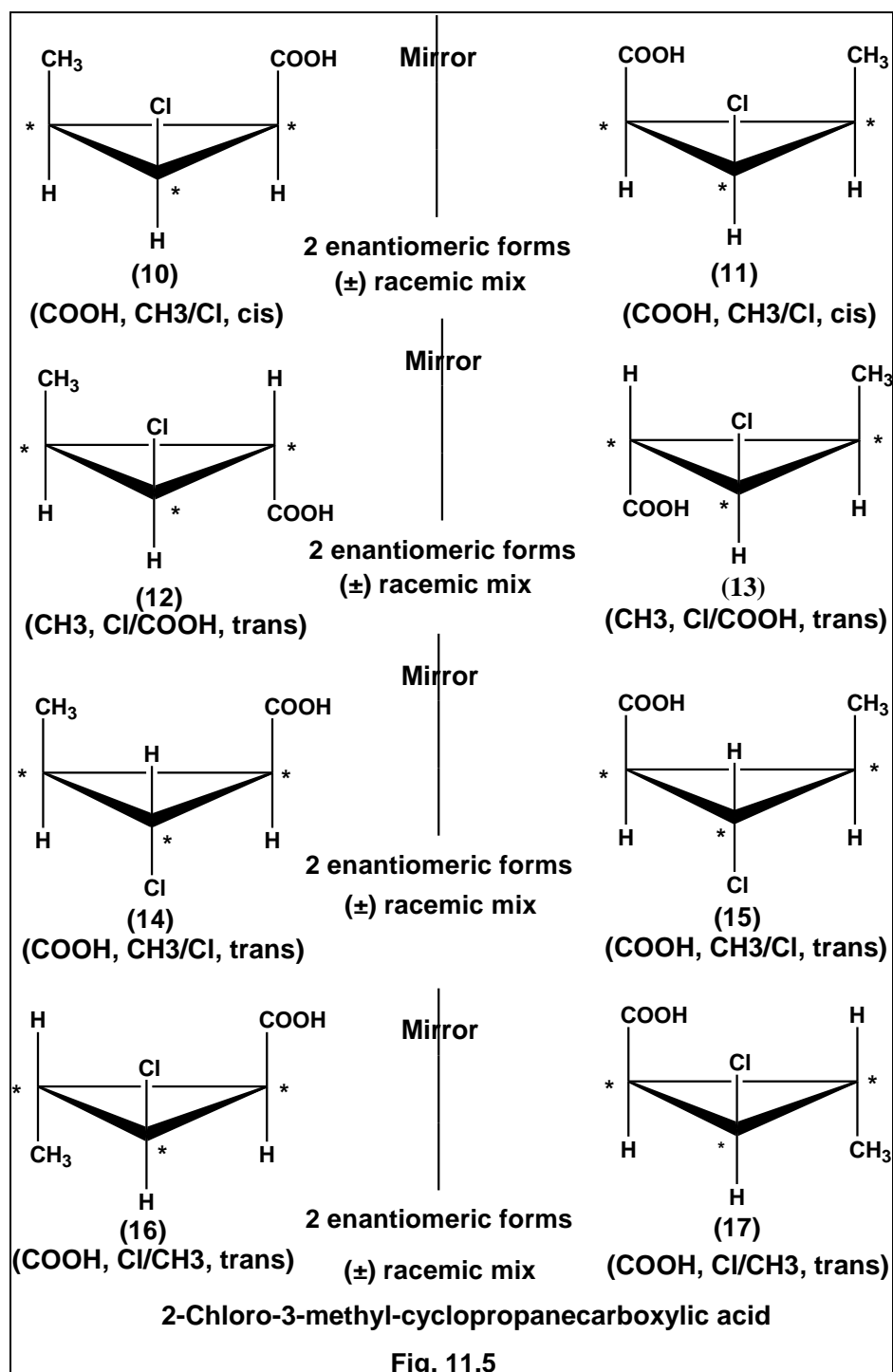



From the example in (Fig. 11.5), there are the following;

- (i) 8 Enantiomers (**10**, **11**, **12**, **13**, **14**, **15**, **16** and **17**).
- (ii) 4 Racemic mixtures (\pm).
- (iii) 4 Geometrical isomers [(**CH3**, **Cl**/ **COOH**, *cis*), (**CH3**, **Cl**/ **COOH**, *trans*), (**CH3**, **COOH**/ **Cl**, *trans*) and (**Cl**, **COOH**/ **CH3**, *trans*)].

11.4 Two similar asymmetric carbon atoms and the third carbon is pseudo asymmetric

When two substituents of cyclopropane are the same and the third substituent is different, there are two chiral centers (**2C***) to form 2 enantiomers (**Xa** and **Xb**) combine together to form one racemic mixture (\pm), and 2 meso-forms (**VIII** and **IX**), in addition to 3 geometrical isomers (Fig. 11.6). The third different atom (- **CHb**-) is pseudo asymmetric, which does not bring a new configuration, e.g., 3-bromo-1,2-propane dicarboxylic acid (Fig. 11.6).

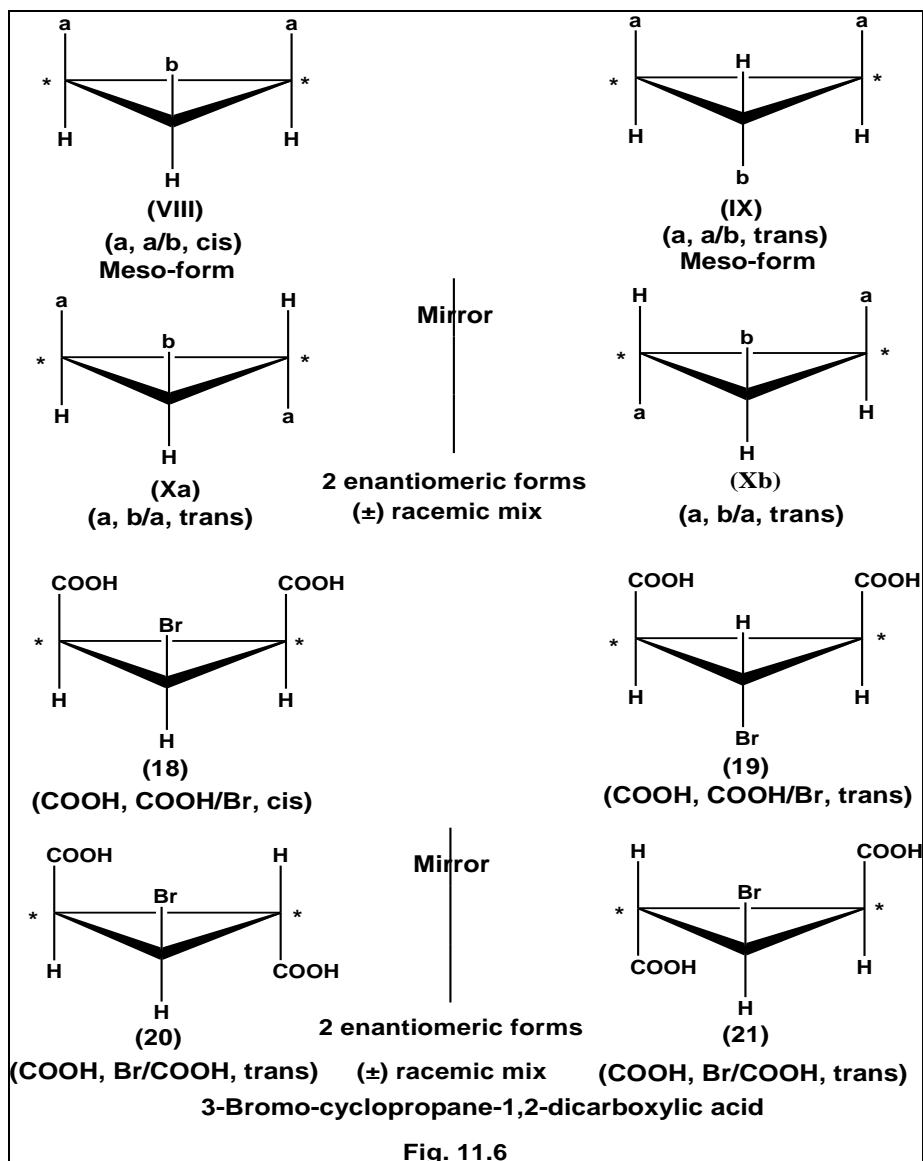

From the example in (Fig. 11.6), there are the following;

- (i) 2 Enantiomers (**20** and **21**).
- (ii) One racemic mixture (±).
- (iii) 2 Meso-forms (**18** and **19**).
- (iv) 3 Geometrical isomers [(COOH, COOH/ Br, *cis*), (COOH, COOH/ Br, *trans*) and (COOH, Br/ COOH, *trans*)].



Activities: Find the possible geometrical and optical isomers for each of the following substituted cyclopropane:

- (i) **2-bromo-3-methyl-1-cyclopropanol.**
- (ii) **1,1-dichloro-cyclopropanecarbaldehyde.**

Summary

- **Cyclopropane with one chiral carbon atom:** exists in a pair of enantiomers combine together to give a racemic mixture.
- **Cyclopropane with with two chiral carbon atoms :**
- **a- Two different chiral atoms:** 1,2-disubstituted-cyclopropane with two different substituents exists in two enantiomeric pairs and two racemic mixtures (\pm), with 2 geometrical isomers.
- **b- Two similar chiral carbon atoms:** 1,2-disubstituted-cyclobutane with two identical substituents exists in a pair of enantiomers and a meso-form with 2 geometrical isomers.
- **Cyclopropane with three different chiral carbon atoms:** exists in 4 pairs of enantiomers and 4 racemic mixtures (\pm), in addition to 4 geometrical isomers.
- **Cyclopropane with two similar chiral carbon atoms and the third carbon is pseudo asymmetric:** when two substituents of are the same and the third is different which considered a pseudo asymmetric, there are two chiral centers only to form 2 enantiomers combine together to form one racemic mixture, and 2 meso-forms, in addition to 3 geometrical isomers.

Lecture 12

12. Stereochemistry of cyclobutane derivatives

As we mentioned before, cyclobutane has a puckered shape as in the following figure (Fig. 12.1).

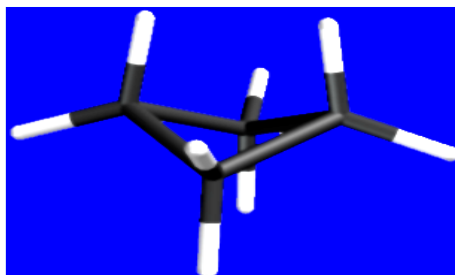
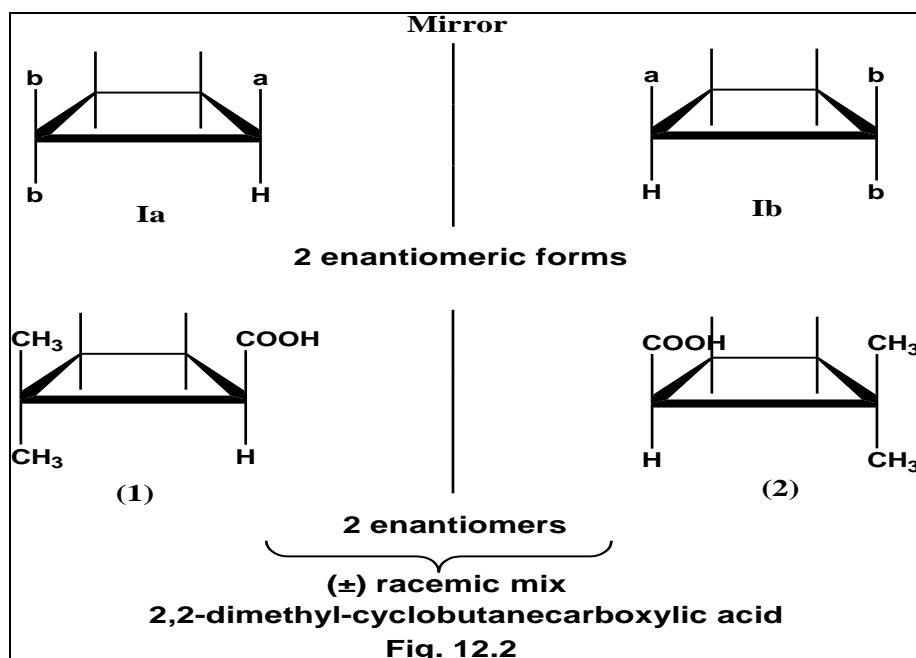

Fig. 12.1

12.1 Molecules with one chiral carbon atom

When a substituted cyclobutane as in (Fig. 12.2) has one chiral carbon atom (C^*), it can exist in two optically active enantiomers (**Ia** and **Ib**) and one racemic mixture, e. g., 2,2-dimethylcyclobutane carboxylic acid (Fig. 12.2).



In the above example, there are two enantiomeric forms (**1** and **2**), and one racemic mixture (\pm).

12.2 Molecules with two chiral carbon atoms

a- Two different chiral atoms

When 1,2-disubstituted-cyclobutane has two different substituents, there are two enantiomeric pairs (**IIa**, **IIb** and **IIc**, **IId**) and two racemic mixtures (\pm) (Fig. 12.3). In addition to that, two geometrical isomers *cis*- and *trans*-, e. g., 2-methyl-cyclobutanecarboxylic acid (Fig. 12.3).

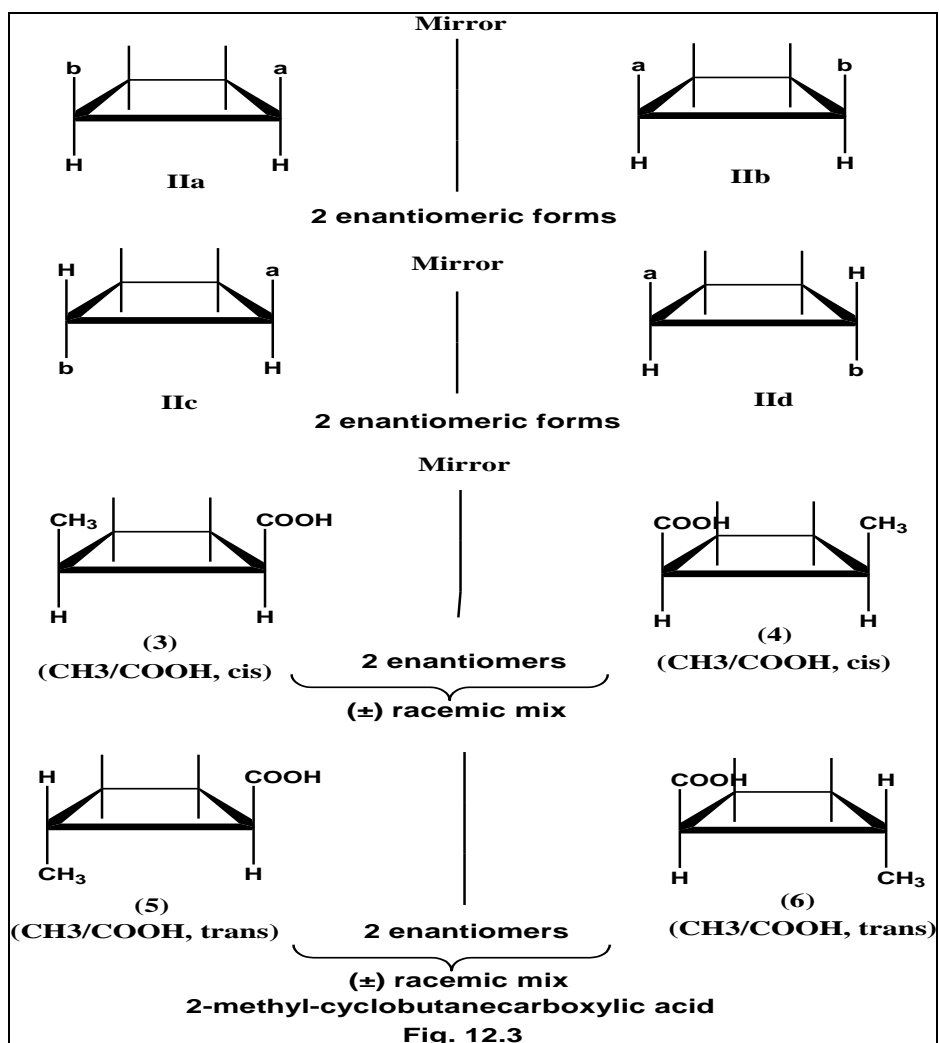



From the above example (Fig. 12.3), there are the following;

- (iv) Two enantiomeric pairs (**3, 4** and **5, 6**).
- (v) Two racemic mixtures (\pm).
- (vi) Two geometrical isomers [(**CH₃/ COOH, cis**) and (**CH₃/ COOH, trans**)].

b- Two similar chiral carbon atoms

When 1,2-disubstituted-cyclobutane has two identical substituents, there are a pair of enantiomers and a meso-form (Fig. 12.4).

The **cis**-isomer has a plane of symmetry and is there for optically inactive meso-form (**IIIa**), the **trans**-isomer exists in two optically active enantiomers (**IIIb** and **IIIc**) to form one racemic mixture (\pm), e. g., cyclobutane-1,2-dicarboxylic acid (Fig. 12.4).

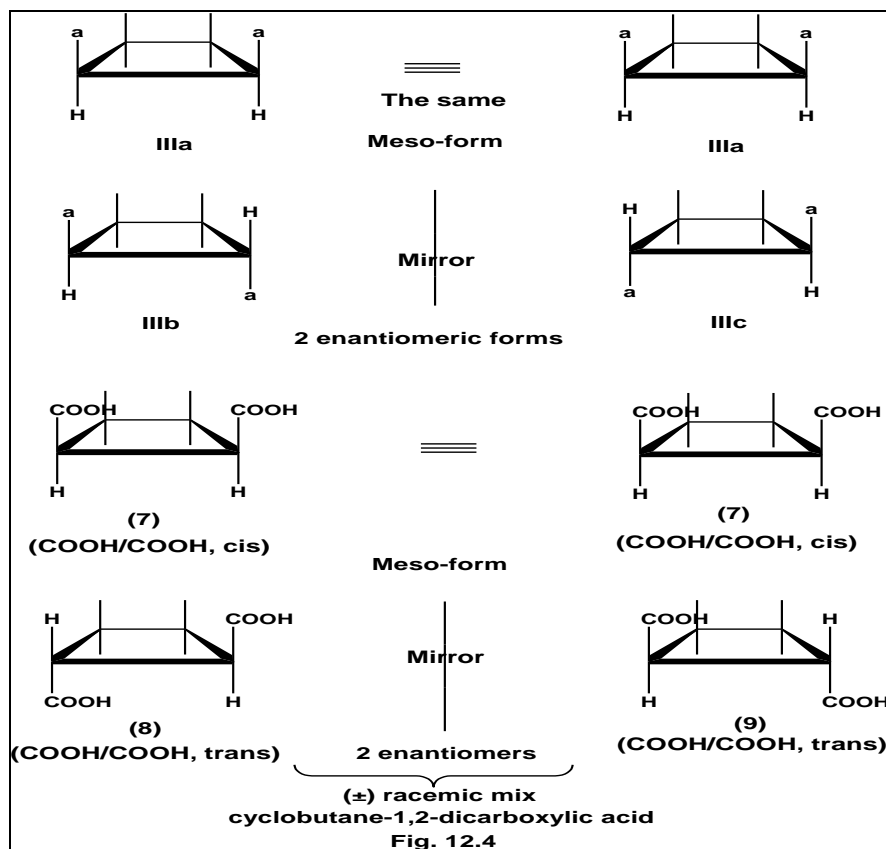

From the example in (Fig. 12.4), there are the following;

- (v) Pair of enantiomers (**8** and **9**).
- (vi) (\pm) Racemic mixture of the 2 enantiomers.
- (vii) Meso-form (**7**).
- (viii) Two geometrical isomers [(**COOH/ COOH, cis**) and (**COOH/ COOH, trans**)].

12.3 Molecules with three different chiral carbon atoms

When cyclobutane contains 3 chiral carbon atoms, there are ($2^n = 2^3 = 8$) optically active isomers, i. e., 4 pairs of enantiomers (**IVa, IVb; Va, Vb; VIa, VIb** and **VIIa, VIIb**) (Fig. 12.5), and 4 racemic mixtures (\pm). In addition to 4 geometrical isomers.

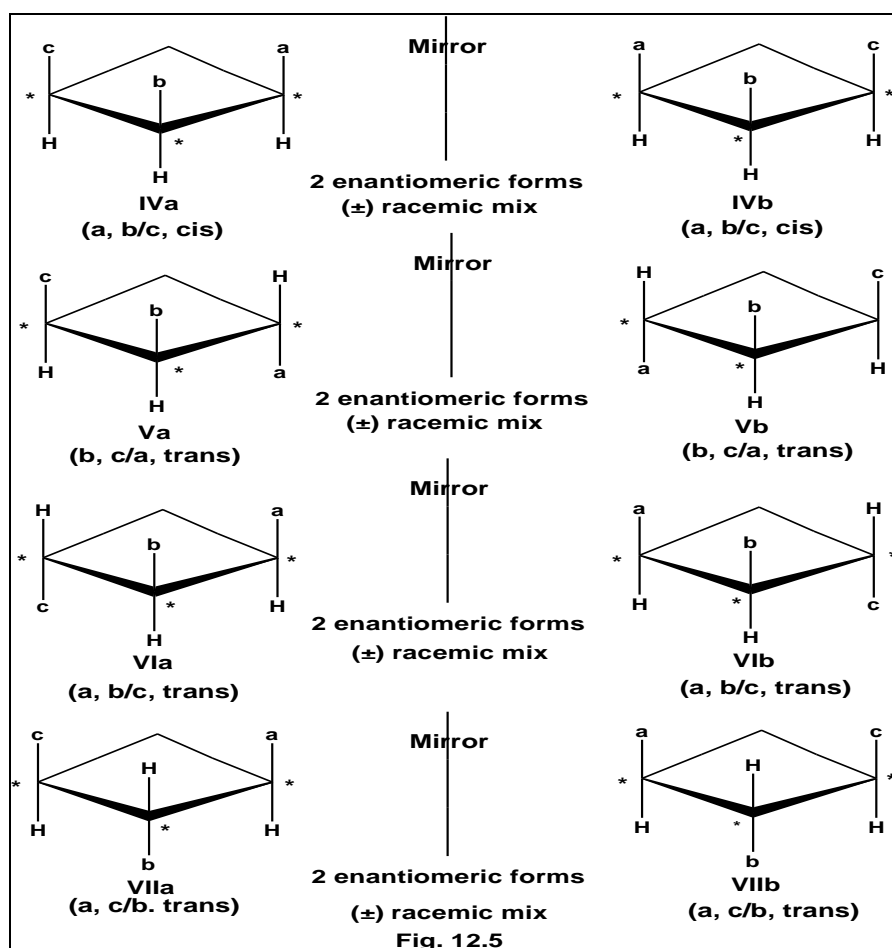

Ex: 2-chloro-3-methyl-cyclobutanecarboxylic acid (Fig. 12.6).

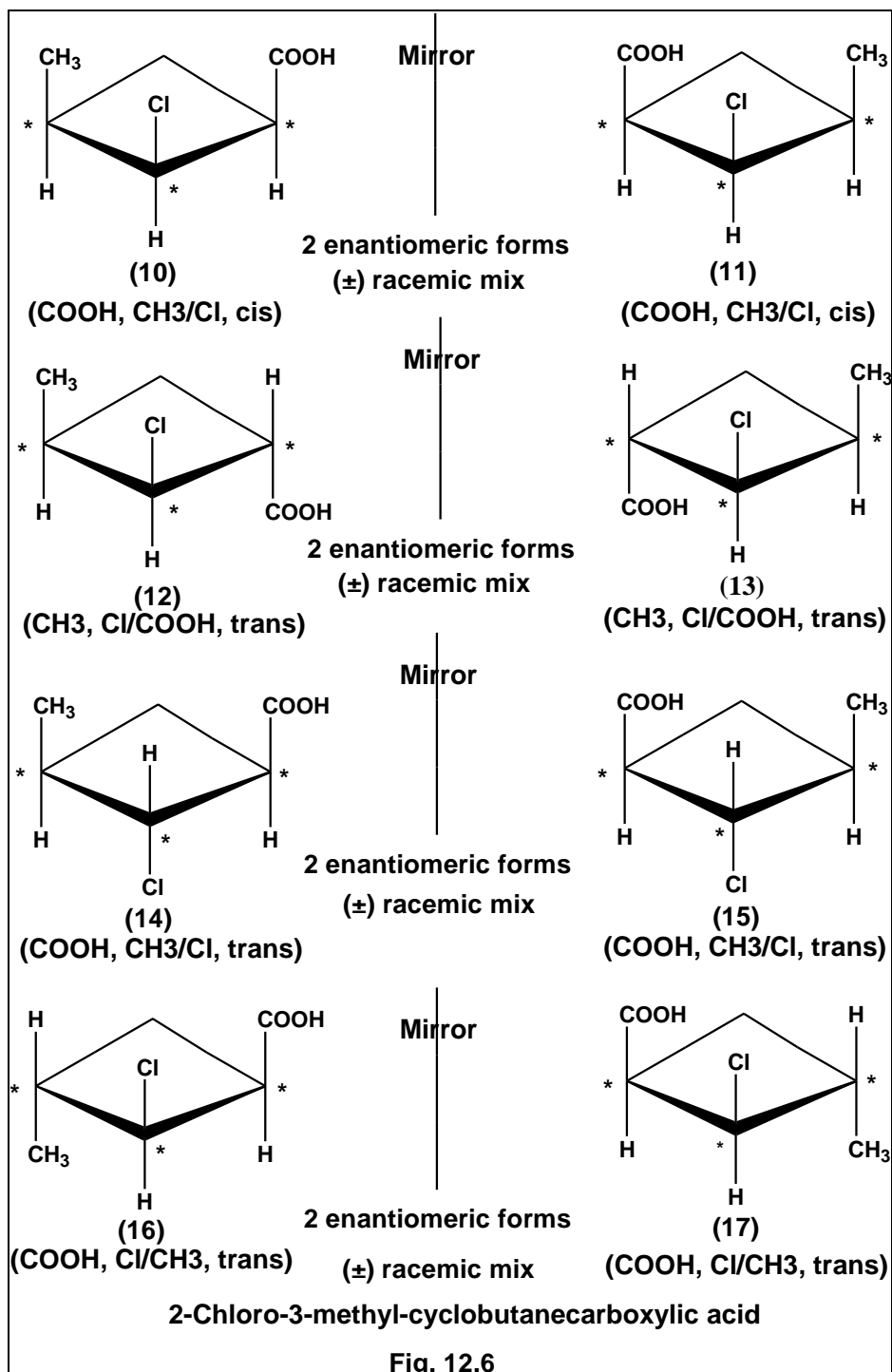

From the example in (Fig. 12.6), there are the following;

- (iv) 8 Enantiomers (**10, 11, 12, 13, 14, 15, 16** and **17**).
- (v) 4 Racemic mixtures (\pm).
- (vi) 4 Geometrical isomers [(**CH₃, Cl/ COOH, cis**), (**CH₃, Cl/COOH, trans**), (**CH₃, COOH/ Cl, trans**) and (**Cl, COOH/ CH₃, trans**)].

Activities: Find the possible geometrical and optical isomers of 3-chloro-2-nitro-cyclobutanecarboxylic acid.

12.4 1,3-disubstituted-cyclobutane

When the two substituents of 1,3-disubstituted-cyclobutane are the same, there are two geometrical isomers only, both being meso-forms.

The 2 geometrical isomers are **VIII (a /a, cis)** with vertical diagonal plane of symmetry "Meso (1)", and **IX (a /a, trans)** with a center of symmetry "Meso (2)", e.g., 1,3-dimethylcyclobutane (Fig. 12.7).

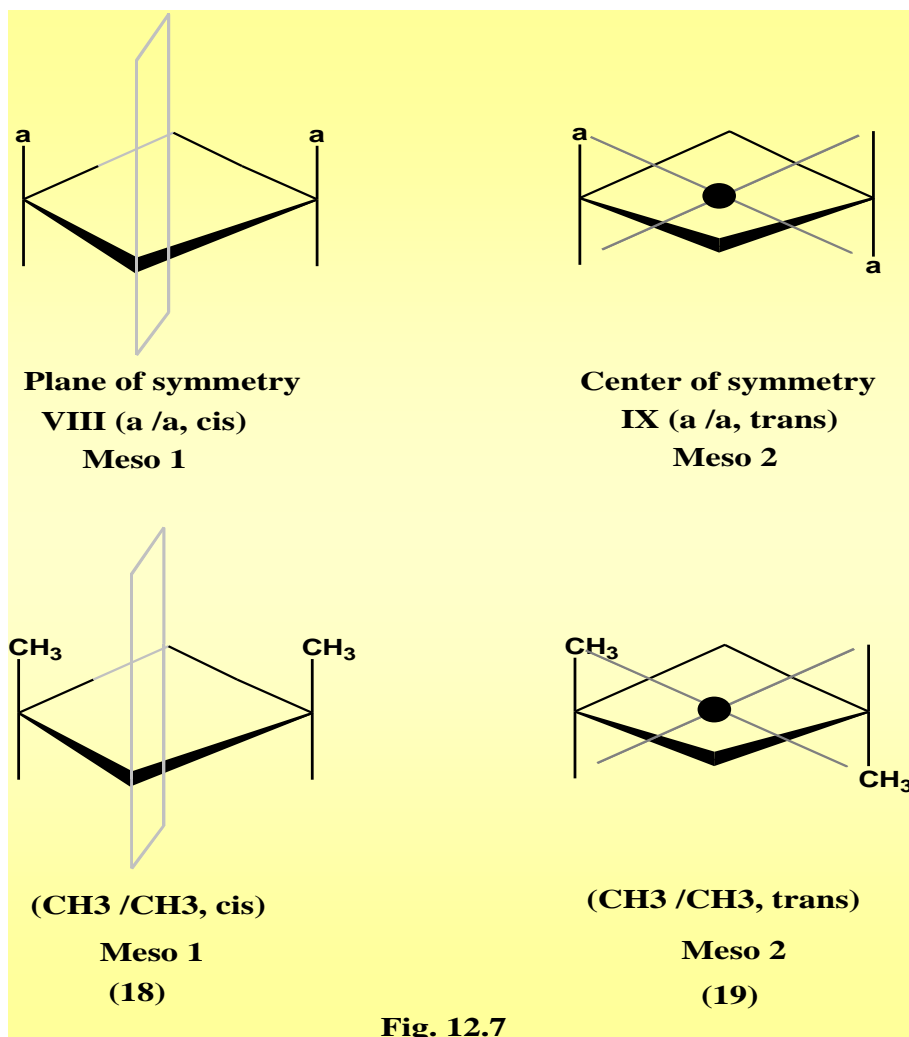

From the example in (Fig. 12.7), there are only 2 geometrical isomers (**18** and **19**), each one is a meso-form.

Activities: Try to draw the possible isomers of Cyclobutane-1,3-dicarboxylic acid and 2-methyl-cyclobutan-1-ol.

Summary

- **Cyclobutane with one chiral carbon atom:** exists in two enantiomeric forms combine together to yield one racemic mixture.
- **Cyclobutane with with two chiral carbon atoms :**
- **a- Two different chiral atoms:** when 1,2-disubstituted-cyclobutane has two different substituents, there are two enantiomeric pairs and two racemic mixtures (\pm), with 2 geometrical isomers.
- **b- Two similar chiral carbon atoms:** 1,2-disubstituted-cyclobutane with two identical substituents exists in a pair of enantiomers and a meso-form with 2 geometrical isomers.
- **Cyclobutane with three different chiral carbon atoms:** exists in 4 pairs of enantiomers and 4 racemic mixtures (\pm), in addition to 4 geometrical isomers.
- **1,3-disubstituted-cyclobutane:** with two identical substituents exists in only two geometrical isomers, both being meso-forms.

Lecture 13

13. Stereochemistry of cyclohexane

13.1 Flexible conformers of cyclohexane

Cyclohexane is the most important of all the ring systems, it can exist in a number of flexible forms in all of which angle strain is largely eliminated. These forms are known as chair, half-chair, boat, and twist-boat (Fig 13.1).

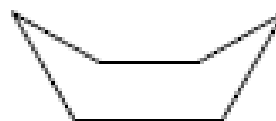

The chair-form of cyclohexane

The boat-form of cyclohexane

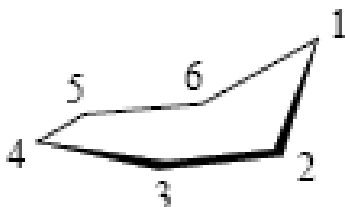

The half-chair form
of cyclohexane

The twist-boat form of
of cyclohexane

Fig. 13.1

The relative energies of the different forms of cyclohexane are shown in the following energy diagram (Fig. 13.2).

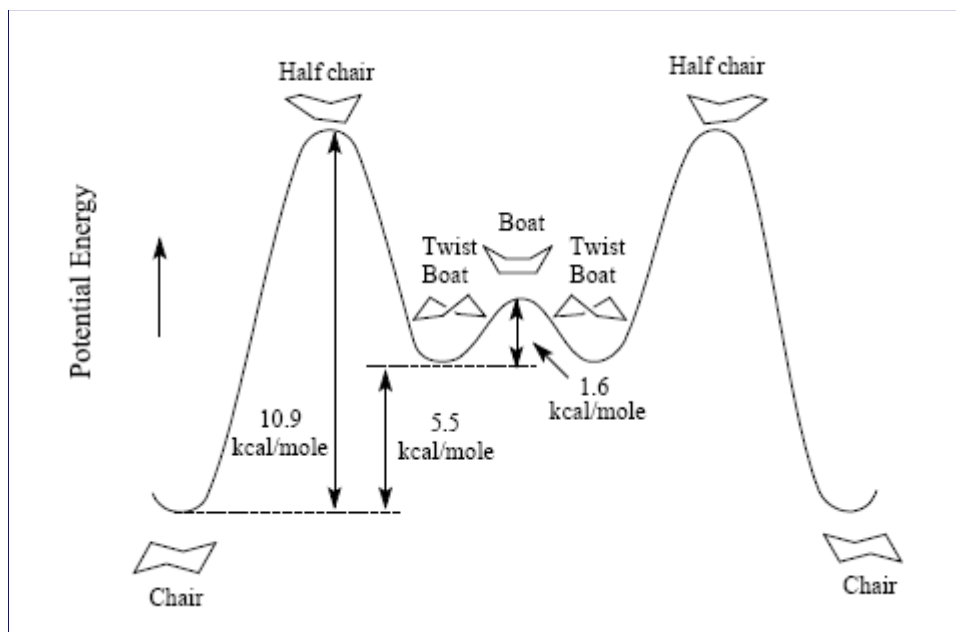

The energy diagram for the ring inversion of cyclohexane.
Fig. 13.2

From the above diagram, it can be concluded that:

- 1- The chair-form is the most stable conformation of cyclohexane, and indeed of nearly every derivative of cyclohexane (about 99.9% of cyclohexane molecules are in the chair-form at any time) (Fig. 13.3).

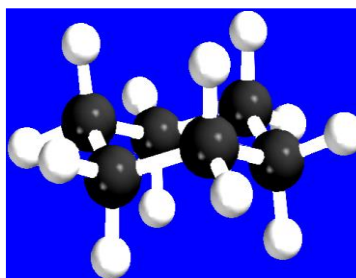

A ball-and-stick model of the chair-form of cyclohexane

Fig. 13.3

The stability of the chair-form is due to the following reasons:

- (i) The chair-form is the less energy one.
- (ii) The chair-form is free of angle strain (α), and torsional strain.
- (iii) All hydrogen atoms in the chair-form are staggered in four of its carbon atoms as shown in (Fig. 13.4).

2- The boat-form of cyclohexane has eclipsed bonds in four of its carbon atoms, this eclipsing produces a significant amount of torsional strain. This torsional strain increases the energy of the boat-form and destabilizes it (Fig. 13.4).

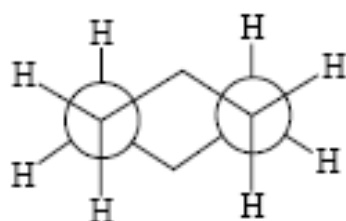

**New man projection
of the chair-form**

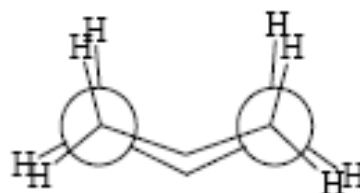

**Newman projection
of the boat-form**

Fig. 13.4

3- A third conformation of cyclohexane is the twist-boat (Fig. 13.5), there is a relieving in this form minimize the torsional strain and the Van der Waal repulsion and make the twist-boat is lower in energy than the boat-conformation.

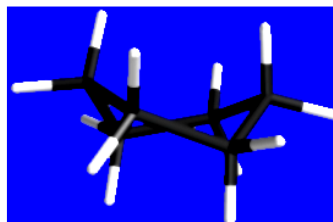
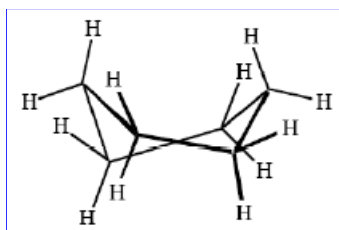

The twist-boat form of cyclohexane (Fig. 13.5)

- 4- The last conformation is called half-chair, which has an almost-planar structure. So, it has the highest energy (Fig. 13.6).

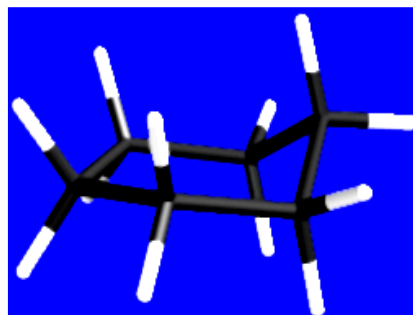
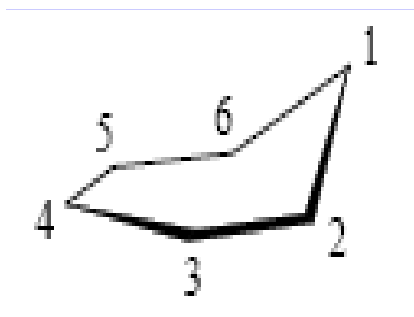

The half-chair form of cyclohexane

Fig. 13.6

13.2 How to Draw a Chair Conformation of Cyclohexane?

Drawing a chair conformation of cyclohexane is not difficult but does require some practice. The rules are quite simple. First, draw the “seat” of the chair. They are two slanted and slightly offset parallel lines.

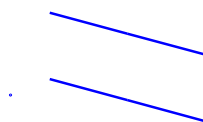

Next, draw two more parallel lines connecting the first lines with the “footrest” and “headrest” carbons.

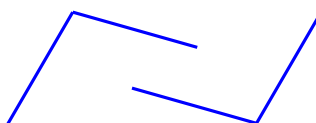

Finally, add two more parallel lines connecting to the footrest and headrest carbons with the two lines of the “sides” of the chair to complete the ring.

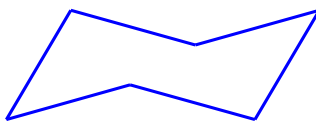

Of course, the chair can also be drawn as follows:

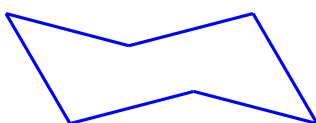

13.3 Axial and equatorial hydrogens of cyclohexane

The chair conformation of cyclohexane has two distinct types of carbon—hydrogen bonds: **axial** and **equatorial**. Six of these bonds are **axial** and the other six **equatorial**, with one axial and one equatorial bond on each carbon (Fig. 13.7).

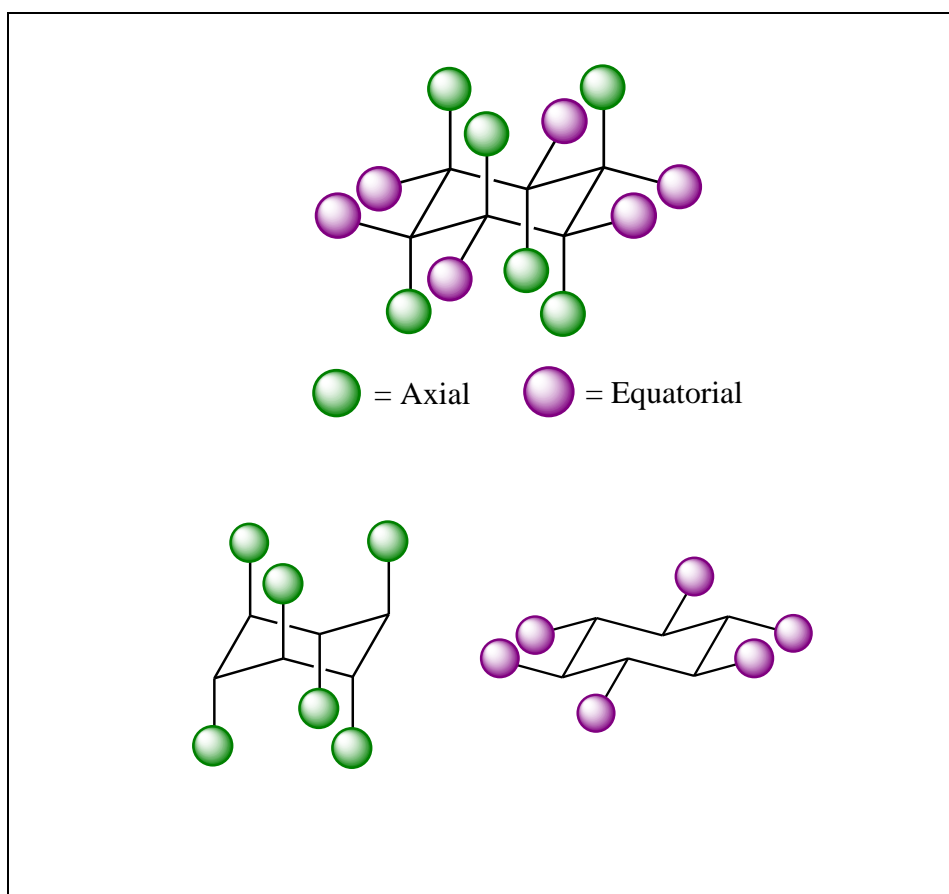

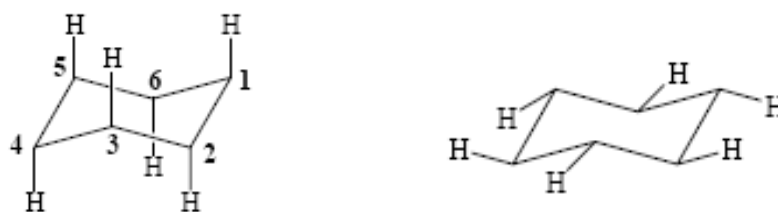

Axial hydrogens of cyclohexane Equatorial hydrogens of cyclohexane

Fig. 13.7

13.4 Conformational inversion of cyclohexane

Through a process called **ring flipping**, or chair-chair interconversion, one chair form of cyclohexane converts to another chair form of cyclohexane. In this process of ring flipping, the equatorial substituents become axial, and the axial substituents become equatorial (Fig. 13.8).

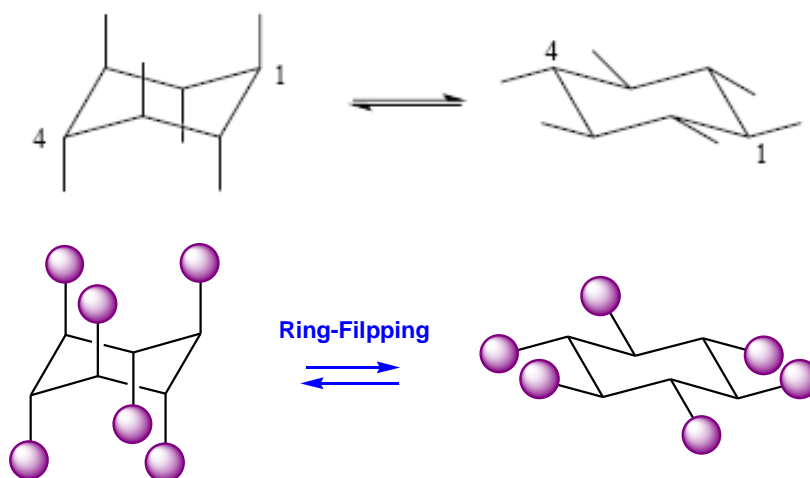

Axial hydrogens of cyclohexane Euatorial hydrogens of cyclohexane

Fig. 13.8



Activities: Try several times to draw a chair conformation of cyclohexane, then draw all the axial and equatorial hydrogens, then draw all the above after ring flipping.

13.5 Conformations of monosubstituted-cyclohexanes

A monosubstituted cyclohexane such as **methylcyclohexane** has two low-energy conformers, one in which the **Me** group is **axial** and one in which it is **equatorial**. The axial conformer is almost always less stable than the equatorial conformer. This is because in the axial conformer there is a steric interaction between the axial Me group on **C1** and the axial hydrogen atoms on **C3** and **C5**. These are called **1,3-diaxial interactions**. In the equatorial conformer, the only 1,3-diaxial interactions occur between H atoms, which are smaller.

The difference in energy between the axial and equatorial conformers of methylcyclohexane is 1.8 kcal/mol (Fig. 13.9).

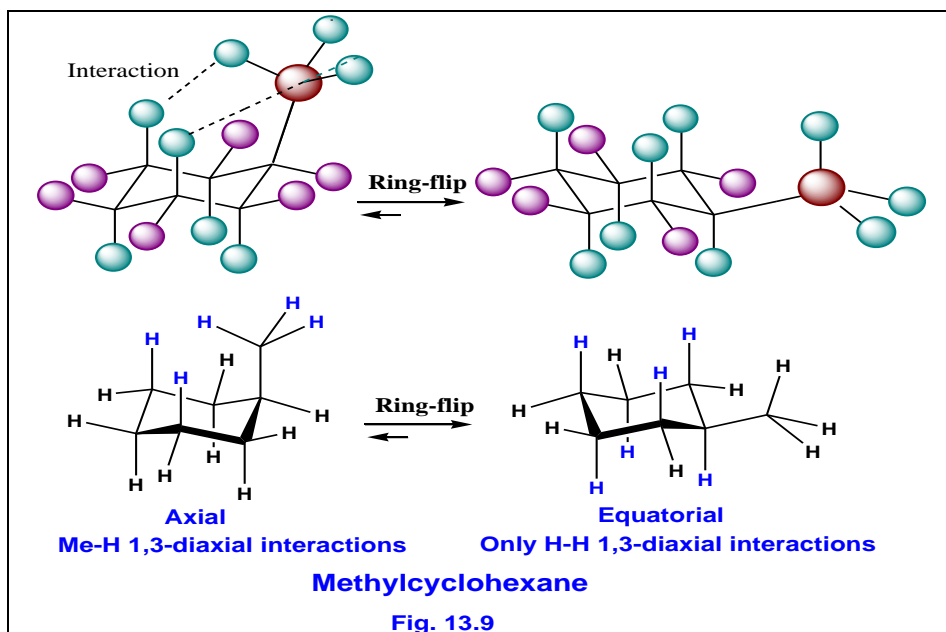

13.6 Conformational analysis of disubstituted cyclohexanes

In disubstituted cyclohexane the steric effects of both substituents must be taken into account in both conformations

A- Conformational analysis of 1,2-disubstituted cyclohexanes

There are two isomers of 1,2-dimethylcyclohexane. **Cis-** and **trans-**, the *cis*-1,2-dimethylcyclohexane can exist in two chair conformations; (**1a2e**) and its ring-flipped (**1e2a**), where: (**a** = axial; **e** = equatorial). Both *cis*-conformers are equal in energy (Fig. 13.10).

The *trans*-1,2-dimethylcyclohexane can exist in two chair conformations; (**1a2a**) and its ring-flipped (**1e2e**).

The diaxial (**1a2a**) conformer is less stable than the diequatorial (**1e2e**) conformer. This is because in the diaxial conformer there are four **1,3-diaxial interactions** between the axial methyl groups and the axial hydrogens, while, in (**1e2e**) conformer there is no 1,3-diaxial interactions (Fig. 13.10).

So, *trans*-1,2-dimethylcyclohexane will exist almost exclusively (>99%) in the diequatorial conformation.

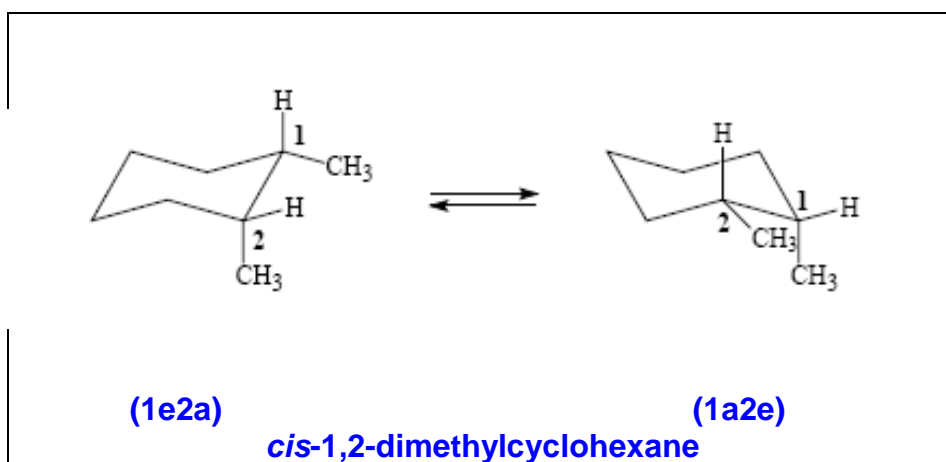

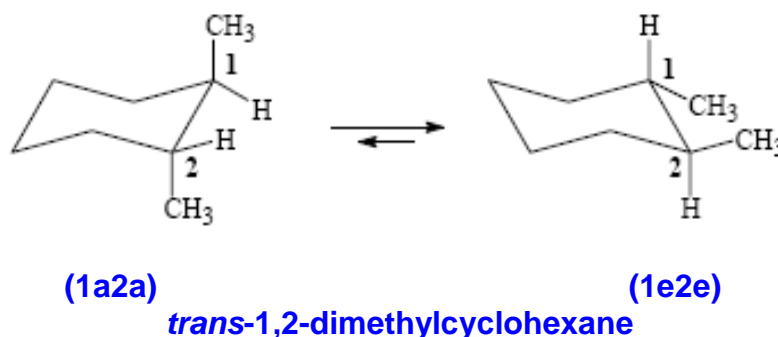

Fig. 13.10

The *trans*-1,2-dimethylcyclohexane is more stable than the *cis*-1,2-dimethylcyclohexane, and the stability sequence of 1,2-dimethylcyclohexane conformers as follows:

The *trans*-1,2-dimethylcyclohexane (1e2e >> 1a2a) is more stable than the *cis*-1,2-dimethylcyclohexane (1a2e ≡ 1e2a).

Now, what can we say about the possible chirality of 1,2-dimethylcyclohexane?

The *trans*-1,2-dimethylcyclohexane (1a2a or 1e2e) exists as a pair of conformational enantiomers. Also, the *cis*-1,2-dimethylcyclohexane (1a2e ≡ 1e2a) exists as a pair conformational enantiomers, each pair of enantiomers combine together to give a racemic mixture. The conformations of the *cis*- and *trans*-isomers are diastereoisomers (Fig. 13.11).

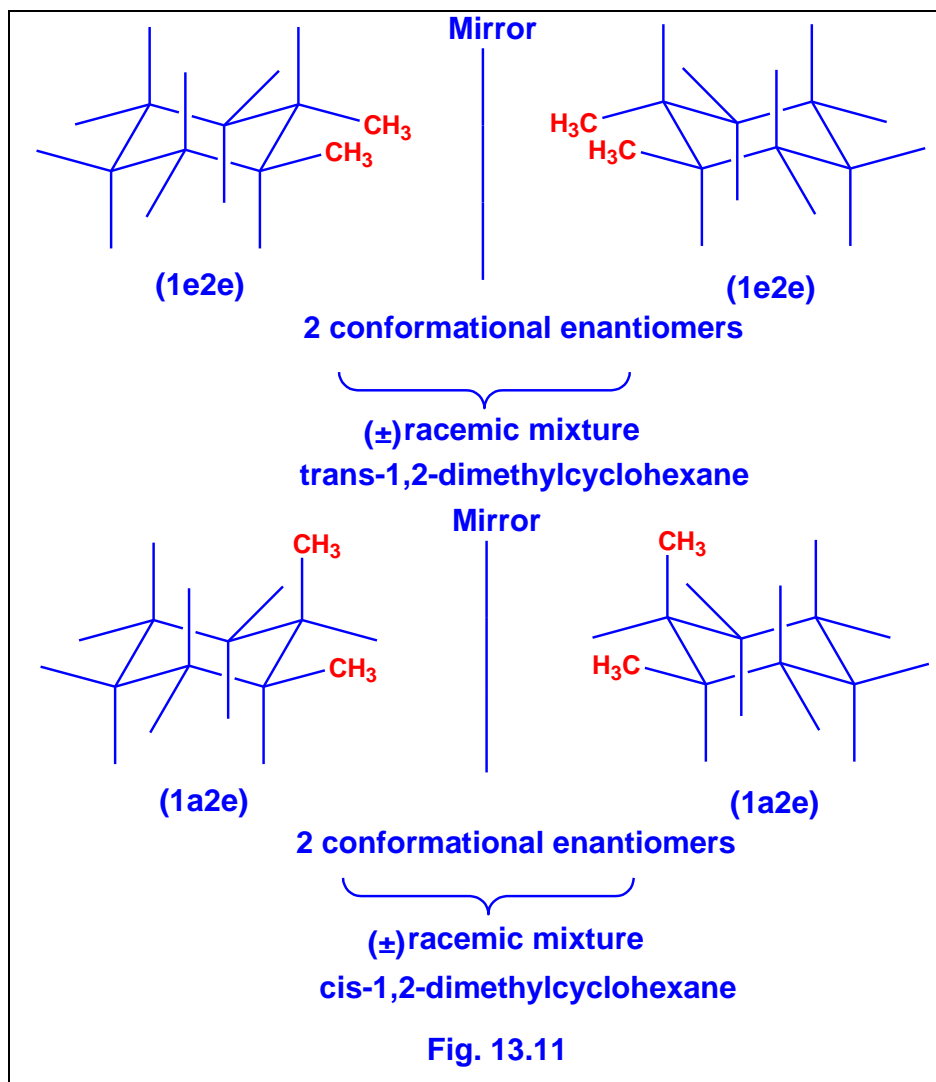

B- Conformational analysis of 1,3-disubstitutedcyclohexanes

1,3-dimethylcyclohexane exists in diastereoisomeric *cis*- and *trans*-forms. In the *cis*-isomer, either both methyl groups are equatorial (1e3e) or both are axial (1a3a), and in the *trans*-isomer, one methyl is equatorial and the other is axial (1a3e or 1e3a). Both *trans*-conformers are equal in energy (Fig. 13.12).

In the *cis*-isomer, the diequatorial (**1e3e**) conformer is more stable than the diaxial (**1a3a**) conformer. This is because in the diaxial conformer, the two methyl groups are on the same side of the ring and crowd each other, while, in the *trans*-isomer, both conformers (**1a3e** or **1e3a**) have one axial methyl, there are two **1,3-diaxial interactions** between the axial methyl and the axial hydrogens.

So, the *cis*-1,3-dimethylcyclohexane is more stable than the *trans*-1,3-dimethylcyclohexane, and the stability sequence of 1,3-dimethylcyclohexane conformers as follows:

The *cis*-1,3-dimethylcyclohexane (**1e3e** >> **1a3a**) is more stable than the *trans*-1,3-dimethylcyclohexane (**1a3e** \equiv **1e3a**).

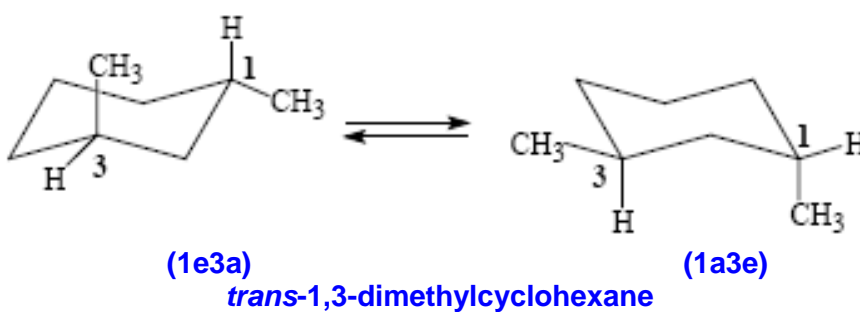
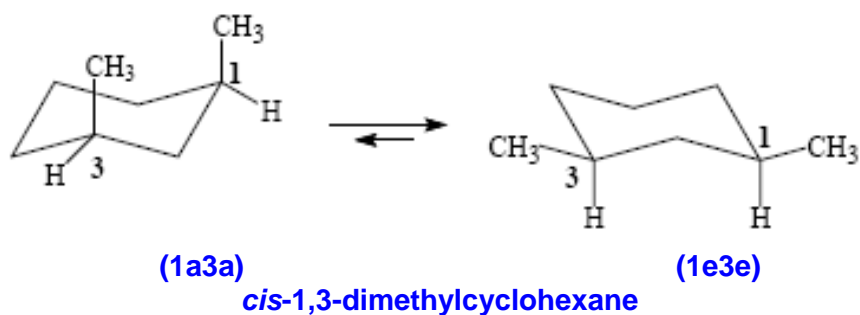
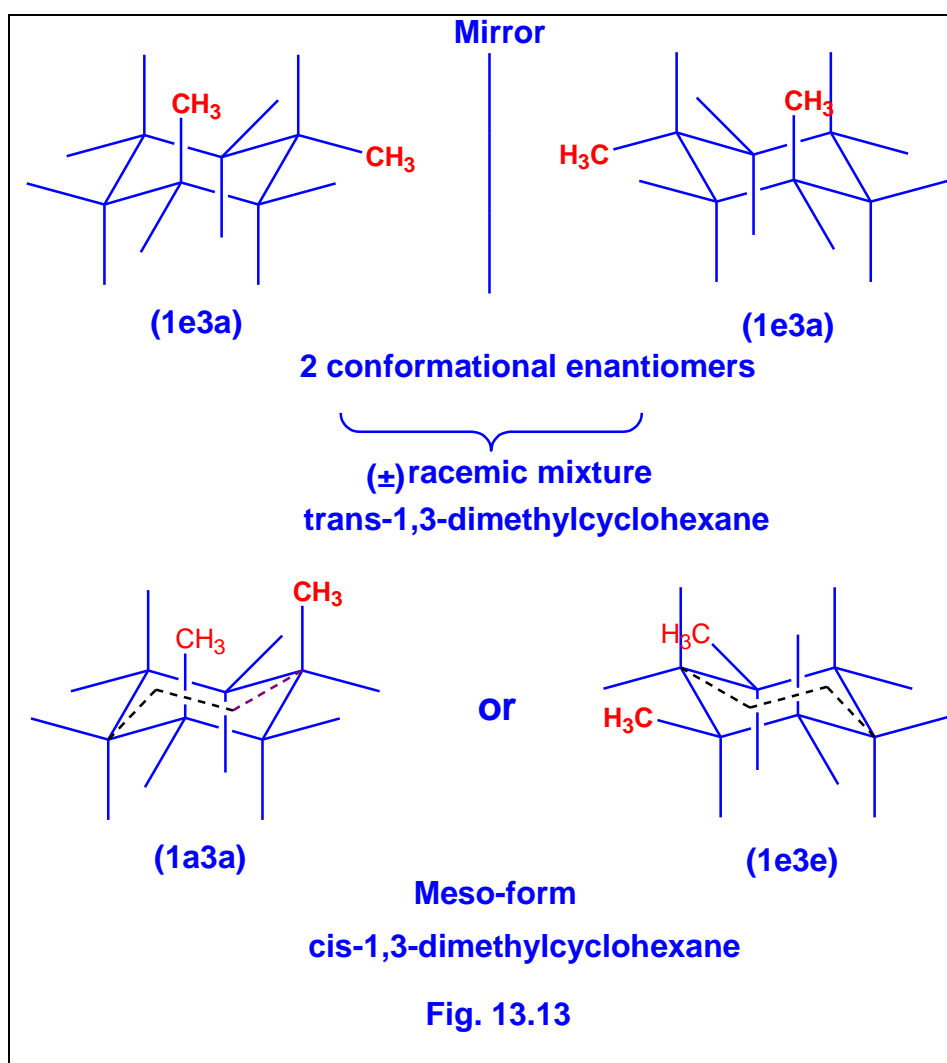

Fig. 13.12

Chirality of 1,3-dimethylcyclohexane:

The *trans*-1,3-dimethylcyclohexane (*1a3e* or *1e3a*) exists as a pair of conformational enantiomers with one racemic mixture. Whereas, in the *cis*-1,3-dimethylcyclohexane (*1e3e* or *1a3a*), there is a plane of symmetry passing through carbon atoms 2 and 5, so the *cis*-isomer is optically inactive meso-form. The conformations of the *cis*- and *trans*-isomers are diastereoisomers (Fig. 13.13).



C- Conformational analysis of 1,4-disubstitutedcyclohexane

There are two diastereoisomeric *cis*- and *trans*-forms, the *cis*-1,4-dimethylcyclohexane can exist in two conformations; (**1a4e**) and its ring-flipped (**1e4a**), and both *cis*-conformers are equal in energy, and the *trans*-1,4-dimethylcyclohexane can exist in two conformations; (**1a4a**) and its ring-flipped (**1e4e**) (Fig. 13.14).

In the *trans*-isomer, the diequatorial (**1e4e**) conformer is more stable than the diaxial (**1a4a**) conformer. This is due to the four **1,3-diaxial interactions** between the axial methyl groups and the axial hydrogens.

The *cis*-isomer, both conformers (**1a4e** or **1e4a**) have one axial methyl, there are two **1,3-diaxial interactions** between the axial methyl and the axial hydrogens.

So, the *trans*-1,4-dimethylcyclohexane is more stable than the *cis*-1,4-dimethylcyclohexane, and the stability sequence of 1,4-dimethylcyclohexane conformers as follows:

The *trans*-1,4-dimethylcyclohexane (**1e4e** >> **1a4a**) is more stable than the *cis*-1,4-dimethylcyclohexane (**1a4e** \equiv **1e4a**).

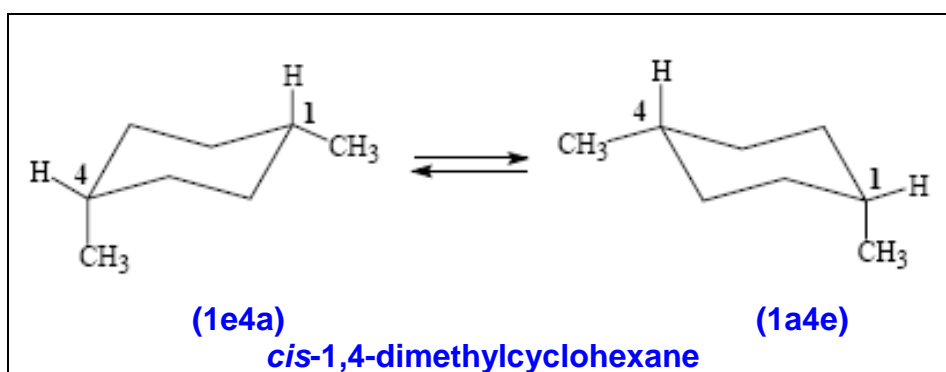

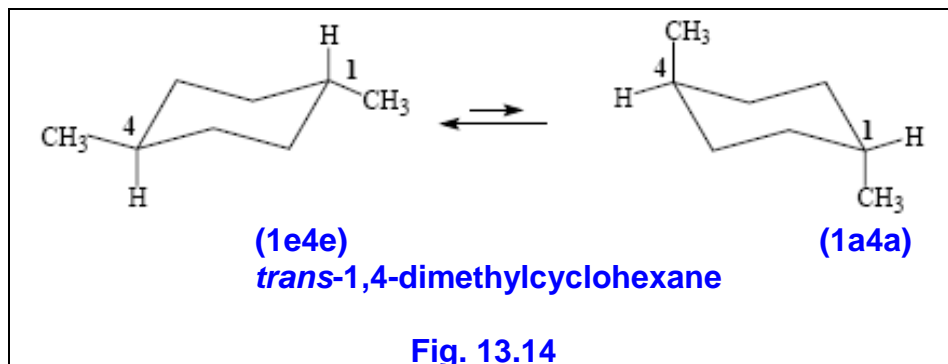

Chirality of 1,4-dimethylcyclohexane:

Both conformational isomers *cis*- and *trans*-1,4-dimethylcyclohexane have a plane of symmetry passing through carbon atoms 1 and 4 and are therefore, optically inactive meso-forms (Fig. 13.15).

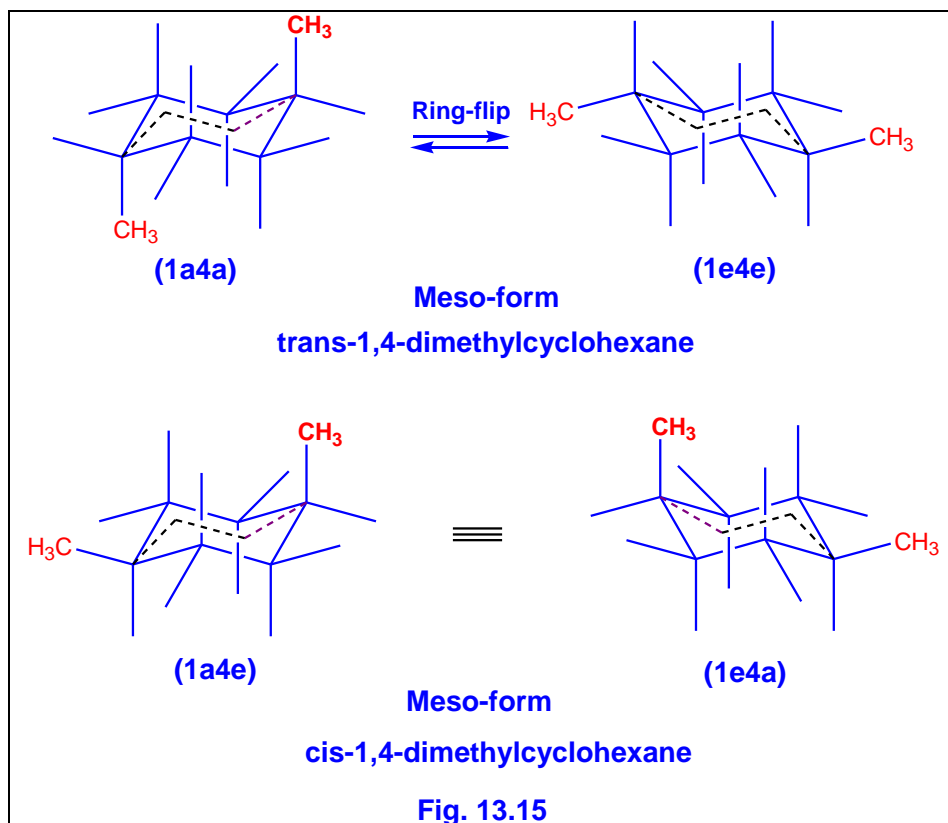

Activities: Try to draw all the possible isomers of *cis*- and *trans*-1,4-dibromocyclohexane in its chair conformations, and determine whether the two chairs are identical, conformational enantiomers, or conformational diastereomers.

13.7 Conformational effects on reactivity

Groups in axial and equatorial positions differ in their thermodynamic stability and in their steric hindrance and these factors influence on the chemical properties of molecules in differing conformations.

Equilibrium reactions will furnish the more stable isomers. For example, when ethyl 4-*t*-butylcyclohexanecarboxylate is heated with sodium ethoxide both the *cis*- and *trans*-isomers produce the same equilibrium mixture containing about 84% of the more stable *trans*-isomer (Fig. 13.16).

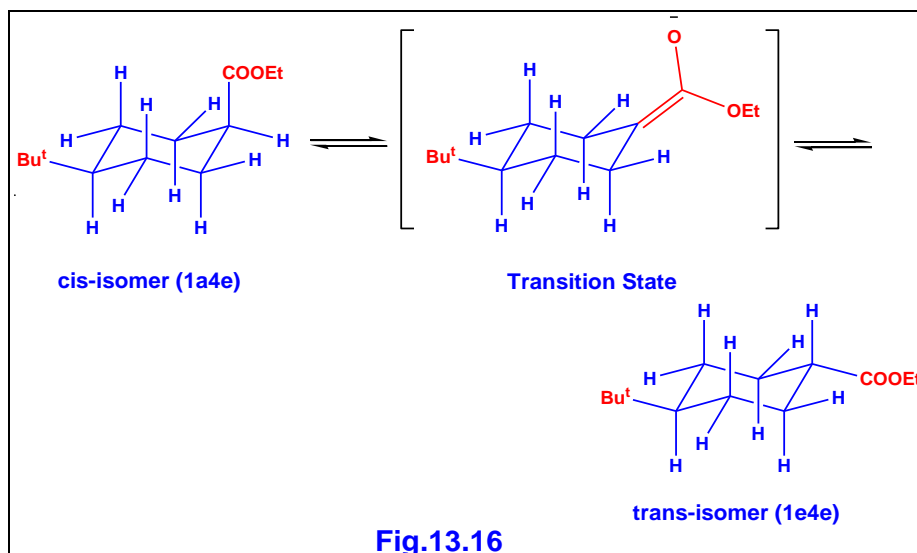

The reactions in which the formation of the transition state is rate-controlling equatorial substituents are more reactive than



similar the axial substituents because of the lower steric restriction of the transition state in the equatorial position, e.g., the esterification of cyclohexanol and cyclohexanecarboxylic acid occurs more rapidly when the hydroxyl or carboxyl group is in equatorial position.

Elimination reactions are most commonly anti-elimination and require an antiperiplanar relationship between the two groups to be eliminated. This is only possible in the diaxial conformation and therefore the *trans*-isomers, which can assume a diaxial conformation, react more readily than the *cis*-isomers, which cannot (Fig. 13.17).

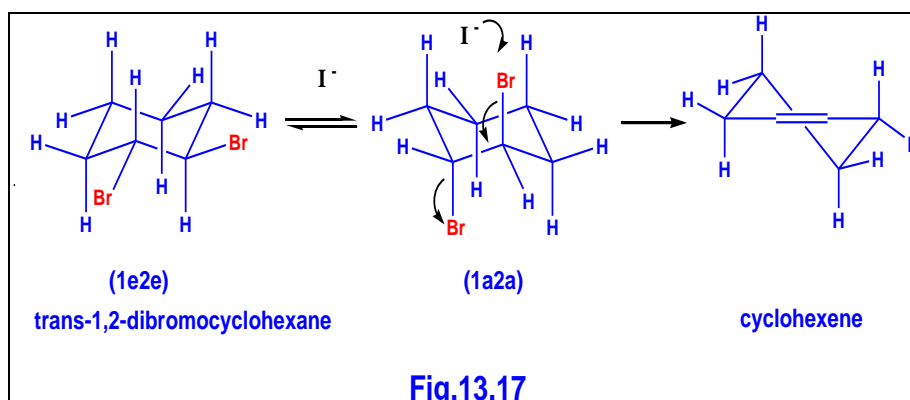

Summary

- **Cyclohexane:** can be exists in a number of flexible forms as chair, half-chair, boat, and twist-boat.
- **The chair-form:** is the most stable conformation of cyclohexane and the least stable one is the half-chair form.
- The chair conformation of cyclohexane has two distinct types of carbon—hydrogen bonds: **axial** and **equatorial**.



- **Ring flipping:** is a chair-chair interconversion, in which, the equatorial substituents become axial, and the axial substituents become equatorial.
- **Monosubstituted-cyclohexanes:** exists in two conformations, one in which the **Me** group is axial and one in which it is equatorial. The axial conformer is less stable than the equatorial conformer. This is due to the **1,3-diaxial interactions**.
- **1,2-Disubstitutedcyclohexanes:** exists in diastereoisomeric cis- and trans-forms. The cis-isomer can exist in two conformations; (1a2e) and (1e2a), which are equal in energy, and the trans-isomer can exist in two conformations; (1a2a) and (1e2e).
- **The trans-1,2-dimethylcyclohexane (1e2e >> 1a2a) is more stable than the cis-1,2-dimethylcyclohexane (1a2e ≡ 1e2a).**
- The *trans*-1,2-dimethylcyclohexane (1a2a or 1e2e) exists as a pair of enantiomers. Also, the *cis*-1,2-dimethylcyclohexane (1a2e ≡ 1e2a) exists as a pair of enantiomers, each pair of enantiomers combine together to give a racemic mixture.
- **1,3-Disubstitutedcyclohexanes:** exists in diastereoisomeric cis- and trans-forms. The cis-isomer can exist in two conformations; (1a2a) and (1e2e), which are equal in energy, and the trans-isomer can exist in two conformations; (1a2e) and (1e2a).



- The **cis-1,3-dimethylcyclohexane (1e3e >> 1a3a)** is more stable than the **trans-1,3-dimethylcyclohexane (1a3e \equiv 1e3a)**.
- The *trans*-1,3-dimethylcyclohexane (1a3e or 1e3a) exists as a pair of enantiomers with one racemic mixture. Whereas, in the *cis*-1,3-dimethylcyclohexane (1e3e or 1a3a), exists as optically inactive meso-form.
- **1,4-disubstitutedcyclohexane:** exists in diastereoisomeric *cis*- and *trans*-forms. The *cis*-isomer can exists in two conformations; (1a4e) and (1e4a), which are equal in energy, and the *trans*-isomer can exists in two conformations; (1a4a) and (1e4e).
- The **trans-1,4-dimethylcyclohexane (1e4e >> 1a4a)** is more stable than the **cis-1,4-dimethylcyclohexane (1a4e \equiv 1e4a)**.
- Both conformational isomers *cis*- and *trans*-1,4-dimethylcyclohexane have a plane of symmetry passing through carbon atoms 1 and 4 and are therefore, optically inactive meso-forms.