

Concerning 3D-geomery course, teaching source has taken from this link:

<https://www.coursehero.com/file/60350377/Analytical-Solid-Geometrypdf/>

which is clearing in the next pages as:

Chapter 3

Analytical Solid Geometry

3.1 INTRODUCTION

In 1637, Rene Descartes* represented geometrical figures (configurations) by equations and vice versa. Analytical Geometry involves algebraic or analytic methods in geometry. Analytical geometry in three dimensions also known as Analytical solid** geometry or solid analytical geometry, studies geometrical objects in space involving three dimensions, which is an extension of coordinate geometry in plane (two dimensions).

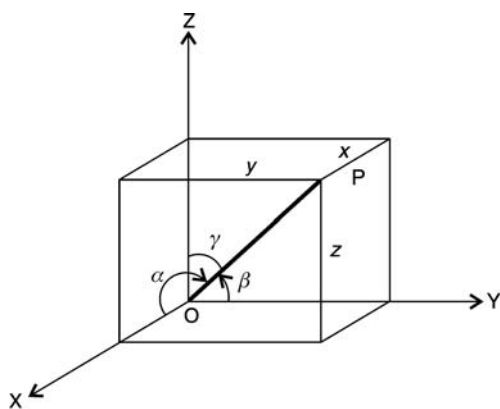

Fig. 3.1

Rectangular Cartesian Coordinates

The position (location) of a point in space can be determined in terms of its perpendicular distances (known as rectangular cartesian coordinates or simply *rectangular coordinates*) from three mutually perpendicular planes (known as **coordinate planes**). The lines of intersection of these three coordinate planes are known as *coordinate axes* and their point of intersection the *origin*.

The three axes called x-axis, y-axis and z-axis are marked positive on one side of the origin. The positive sides of axes *OX*, *OY*, *OZ* form a right handed system. The coordinate planes divide entire space into eight parts called *octants*. Thus a point *P* with coordinates *x*, *y*, *z* is denoted as $P(x, y, z)$. Here *x*, *y*, *z* are respectively the perpendicular distances of *P* from the *YZ*, *ZX* and *XY* planes. Note that a line perpendicular to a plane is perpendicular to every line in the plane.

Distance between two points $P_1(x_1, y_1, z_1)$ and $P_2(x_2, y_2, z_2)$ is $\sqrt{(x_2-x_1)^2+(y_2-y_1)^2+(z_2-z_1)^2}$.

Distance from origin $O(0, 0, 0)$ is $\sqrt{x_2^2 + y_2^2 + z_2^2}$.

Divisions of the line joining two points P_1, P_2 : The coordinates of $Q(x, y, z)$, the point on P_1P_2 dividing the line segment P_1P_2 in the ratio $m : n$ are $(\frac{nx_1+mx_2}{m+n}, \frac{ny_1+my_2}{m+n}, \frac{nz_1+mz_2}{m+n})$ or putting k for $\frac{m}{n}$, $(\frac{x_1+kx_2}{1+k}, \frac{y_1+ky_2}{1+k}, \frac{z_1+kz_2}{1+k})$; $k \neq -1$. Coordinates of mid point are $(\frac{x_1+x_2}{2}, \frac{y_1+y_2}{2}, \frac{z_1+z_2}{2})$.

* Rene Descartes (1596–1650) French philosopher and mathematician, latinized name for Renatus Cartesius.

** *Not* used in the sense of “non-hollowness”. By a sphere or cylinder we mean a hollow sphere or cylinder.

3.2 — ENGINEERING MATHEMATICS

Direction of a line: A line in space is said to be directed if it is taken in a definite sense from one extreme (end) to the other (end).

Angle between Two Lines

Two straight lines in space may or may not intersect. If they intersect, they form a plane and are said to be coplanar. If they do not intersect, they are called *skew lines*.

Angle between two intersecting (coplanar) lines is the angle between their positive directions.

Angle between two non-intersecting (non-coplanar or skew) lines is the angle between two intersecting lines whose directions are same as those of given two lines.

3.2 DIRECTION COSINES AND DIRECTION RATIOS

Direction Cosines of a Line

Let L be a directed line OP from the origin $O(0, 0, 0)$ to a point $P(x, y, z)$ and of length r (Fig. 1.2). Suppose OP makes angles α, β, γ with the positive directions of the coordinate axes. Then α, β, γ are known as the *direction angles* of L . The cosines of these angles $\cos \alpha, \cos \beta, \cos \gamma$ are known as the *direction cosines* of the line $L(OP)$ and are in general denoted by l, m, n respectively.

Thus

$$l = \cos \alpha = \frac{x}{r}, \quad m = \cos \beta = \frac{y}{r}, \quad n = \cos \gamma = \frac{z}{r}.$$

where $r = \sqrt{x^2 + y^2 + z^2}.$

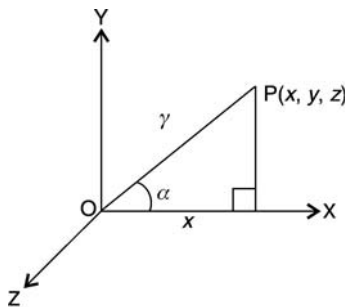

Fig. 3.2

Corollary 1: Lagrange's identity: $l^2 + m^2 + n^2 = 1$ i.e., sum of the squares of the direction cosines of any line is one, since $l^2 + m^2 + n^2 = \cos^2 \alpha + \cos^2 \beta + \cos^2 \gamma = \frac{x^2}{r^2} + \frac{y^2}{r^2} + \frac{z^2}{r^2} = 1.$

Corollary 2: Direction cosines of the coordinate axes OX, OY, OZ are $(1, 0, 0), (0, 1, 0), (0, 0, 1)$ respectively.

Corollary 3: The coordinates of P are (lr, mr, nr) where l, m, n are the direction cosines of OP and r is the length of OP .

Note: Direction cosines is abbreviated as DC's.

Direction Ratios

(abbreviated as DR's:) of a line L are any set of three numbers a, b, c which are proportional to l, m, n the DC's of the line L . DR's are also known as direction numbers of L . Thus $\frac{l}{a} = \frac{m}{b} = \frac{n}{c} = k$ (proportionality constant) or $l = ak, m = bk, n = ck$. Since $l^2 + m^2 + n^2 = 1$ or $(ak)^2 + (bk)^2 + (ck)^2 = 1$ or $k = \frac{\pm 1}{\sqrt{a^2 + b^2 + c^2}}$. Then the actual direction cosines are $\cos \alpha = l = ak = \pm \frac{a}{\sqrt{a^2 + b^2 + c^2}}, \cos \beta = m = bk = \pm \frac{b}{\sqrt{a^2 + b^2 + c^2}}, \cos \gamma = n = ck = \pm \frac{c}{\sqrt{a^2 + b^2 + c^2}}$ with $a^2 + b^2 + c^2 \neq 0$. Here +ve sign corresponds to positive direction and -ve sign to negative direction.

Note 1: Sum of the squares of DR's need not be one.

Note 2: Direction of line is $[a, b, c]$ where a, b, c are DR's.

Direction cosines of the line joining two points $P_1(x_1, y_1, z_1)$ and $P_2(x_2, y_2, z_2)$:

$$l = \cos \alpha = \frac{PQ}{r} = \frac{LM}{r} = \frac{OM - OL}{r} = \frac{x_2 - x_1}{r}.$$

Similarly, $m = \cos \beta = \frac{y_2 - y_1}{r}$ and $n = \cos \gamma = \frac{z_2 - z_1}{r}$. Then the DR's of $P_1 P_2$ are $x_2 - x_1, y_2 - y_1, z_2 - z_1$

ANALYTICAL SOLID GEOMETRY — 3.3

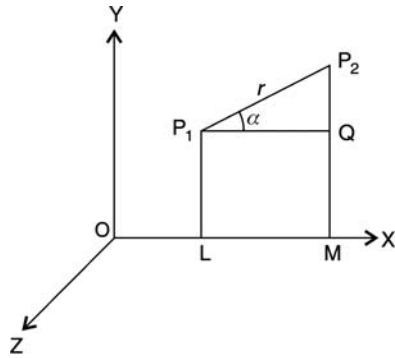

Fig. 3.3

Projections

Projection of a point P on line L is Q , the foot of the perpendicular from P to L .

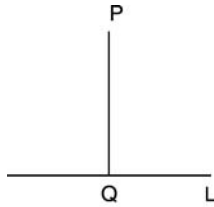

Fig. 3.4

Projection of line segment

P_1P_2 on a line L is the line segment MN where M and N are the feet of the perpendiculars from P and Q on to L . If θ is the angle between P_1P_2 and line L , then projection of P_1P_2 on $L = MN = PR = P_1P_2 \cos \theta$. Projection of line segment P_1P_2 on line L with (whose) DC's l, m, n is

$$l(x_2 - x_1) + m(y_2 - y_1) + n(z_2 - z_1)$$

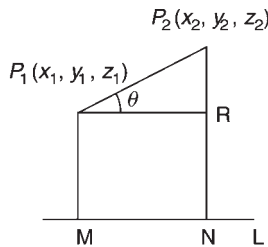

Fig. 3.5

Angle between Two Lines

Let θ be the angle between the two lines OP_1 and OP_2 . Let $OP_1 = r_1, OP_2 = r_2$. Let l_1, m_1, n_1 be DC's of OP_1 and l_2, m_2, n_2 are DC's of OP_2 . Then the coordinates of P_1 are l_1r_1, m_1r_1, n_1r_1 and of P_2 and l_2r_2, m_2r_2, n_2r_2 .

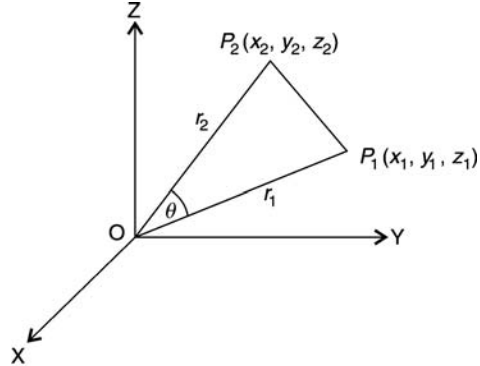

Fig. 3.6

From $\triangle OP_1P_2$, we have

$$\begin{aligned} P_1P_2^2 &= OP_1^2 + OP_2^2 - 2OP_1 \cdot OP_2 \cdot \cos \theta \\ (l_2r_2 - l_1r_1)^2 + (m_2r_2 - m_1r_1)^2 + (n_2r_2 - n_1r_1)^2 \\ &= [(l_1r_1)^2 + (m_1r_1)^2 + (n_1r_1)^2] \\ &\quad + [(l_2r_2)^2 + (m_2r_2)^2 + (n_2r_2)^2] - 2 \cdot r_1r_2 \cos \theta. \end{aligned}$$

Using $l_1^2 + m_1^2 + n_1^2 = 1$ and $l_2^2 + m_2^2 + n_2^2 = 1$,

$$\begin{aligned} r_1^2 + r_2^2 - 2r_1r_2(l_1l_2 + m_1m_2 + n_1n_2) \\ = r_1^2 + r_2^2 - 2r_1r_2 \cos \theta. \end{aligned}$$

Then $\cos \theta = l_1l_2 + m_1m_2 + n_1n_2$

Corollary 1:

$$\begin{aligned} \sin^2 \theta &= 1 - \cos^2 \theta = 1 - (l_1l_2 + m_1m_2 + n_1n_2)^2 \\ &= (l_1^2 + m_1^2 + n_1^2)(l_2^2 + m_2^2 + n_2^2) \\ &\quad - (l_1l_2 + m_1m_2 + n_1n_2)^2 \\ &= (l_1m_2 - m_1l_2)^2 + (m_1n_2 - n_1m_2)^2 \\ &\quad + (n_1l_2 - n_2l_1)^2 \end{aligned}$$

using the Lagrange's identity. Then

$$\begin{aligned} (l_1^2 + m_1^2 + n_1^2)(l_2^2 + m_2^2 + n_2^2) - (l_1l_2 + m_1m_2 + n_1n_2)^2 \\ = (l_1m_2 - l_2m_1)^2 + (m_1n_2 - m_2n_1)^2 + (n_1l_2 - n_2l_1)^2. \end{aligned}$$

3.4 — ENGINEERING MATHEMATICS

Thus $\sin \theta = \frac{\sqrt{\sum(l_1 m_2 - m_1 l_2)^2}}{\dots}$

Corollary 2: $\tan \theta = \frac{\sin \theta}{\cos \theta} = \frac{\sqrt{\sum(l_1 m_2 - m_1 l_2)^2}}{l_1 l_2 + m_1 m_2 + n_1 n_2}$.

Corollary 3: If a_1, b_1, c_1 and a_2, b_2, c_2 are DR's of OP_1 and OP_2

Then $l_1 = \frac{a_1}{\sqrt{a_1^2 + b_1^2 + c_1^2}}, m_1 = \frac{b_1}{\sqrt{a_1^2 + b_1^2 + c_1^2}}, n_1 = \frac{c_1}{\sqrt{a_1^2 + b_1^2 + c_1^2}}$ etc.

Then $\cos \theta = \frac{a_1 a_2 + b_1 b_2 + c_1 c_2}{\sqrt{a_1^2 + b_1^2 + c_1^2} \sqrt{a_2^2 + b_2^2 + c_2^2}}$

$\sin \theta = \frac{\sqrt{(a_1 b_2 - a_2 b_1)^2 + (b_1 c_2 - b_2 c_1)^2 + (c_1 a_2 - c_2 a_1)^2}}{\sqrt{a_1^2 + b_1^2 + c_1^2} \sqrt{a_2^2 + b_2^2 + c_2^2}}$

Corollary: Condition for perpendicularity:

The two lines are perpendicular if $\theta = 90^\circ$. Then

$\cos \theta = \cos 90 = 0$

Thus $l_1 l_2 + m_1 m_2 + n_1 n_2 = 0$

or $a_1 a_2 + b_1 b_2 + c_1 c_2 = 0$

Corollary: Condition for parallelism:

If the two lines are parallel then $\theta = 0$. So $\sin \theta = 0$.

$(l_1 m_2 - m_1 l_2)^2 + (m_1 n_2 - m_2 n_1)^2 + (n_1 l_2 - n_2 l_1)^2 = 0$

or $\frac{l_1}{l_2} = \frac{m_1}{m_2} = \frac{n_1}{n_2} = \frac{\sqrt{l_1^2 + m_1^2 + n_1^2}}{\sqrt{l_2^2 + m_2^2 + n_2^2}} = \frac{1}{1}$

Thus $l_1 = l_2, m_1 = m_2, n_1 = n_2$

or $\frac{a_1}{a_2} = \frac{b_1}{b_2} = \frac{c_1}{c_2}$

WORKED OUT EXAMPLES

Example 1: Find the angle between the lines $A(-3, 2, 4), B(2, 5, -2)$ and $C(1, -2, 2), D(4, 2, 3)$.

Solution: DR's of AB: $2 - (-3), 5 - 2, -2 - 4 = 5, 3, -6$

DR's of CD: $3, 4, 1$. Then DC's of AB are $l_1 = \frac{5}{\sqrt{5^2 + 3^2 + 6^2}} = \frac{5}{\sqrt{25 + 9 + 36}} = \frac{5}{\sqrt{70}}$ and $m_1 =$

$\cos \beta_1 = \frac{3}{70}, n_1 = \cos \gamma_1 = \frac{-6}{\sqrt{70}}$. Similarly, $l_2 = \cos \alpha_2 = \frac{3}{\sqrt{3^2 + 4^2 + 1^2}} = \frac{3}{\sqrt{9 + 16 + 1}} = \frac{3}{\sqrt{26}}$, and $m_2 = \cos \beta_2 = \frac{4}{\sqrt{26}}, n_2 = \cos \gamma_2 = \frac{1}{\sqrt{26}}$. Now

$\cos \theta = \cos \alpha_1 \cdot \cos \alpha_2 + \cos \beta_1 \cdot \cos \beta_2 + \cos \gamma_1 \cdot \cos \gamma_2$
 $= l_1 l_2 + m_1 m_2 + n_1 n_2$
 $\cos \theta = \frac{5}{\sqrt{70}} \cdot \frac{3}{\sqrt{26}} + \frac{3}{\sqrt{70}} \cdot \frac{4}{\sqrt{26}} - \frac{6}{\sqrt{70}} \cdot \frac{1}{\sqrt{26}}$
 $= 0.49225$

$\therefore \theta = \cos^{-1}(0.49225) = 60^\circ 30'$

Example 2: Find the DC's of the line that is \perp^r to each of the two lines whose directions are $[2, -1, 2]$ and $[3, 0, 1]$.

Solution: Let $[a, b, c]$ be the direction of the line. Since this line is \perp^r to the line with direction $[2, -1, 2]$, by orthogonality

$2a - b + 2c = 0$

Similarly, direction $[a, b, c]$ is \perp^r to direction $[3, 0, 1]$. So

$3a + 0 + c = 0$.

Solving $c = -3a, b = -4a$ or direction $[a, b, c] = [a, -4a, -3a] = [1, -4, -3]$.
 \therefore DC's of the line: $\frac{1}{\sqrt{1^2 + 4^2 + 3^2}} = \frac{1}{\sqrt{26}}, \frac{-4}{\sqrt{26}}, \frac{-3}{\sqrt{26}}$.

Example 3: Show that the points $A(1, 0, -2), B(3, -1, 1)$ and $C(7, -3, 7)$ are collinear.

Solution: DR's of AB: $[2, -1, 3]$, DR's of AC: $[6, -3, 9]$, DR's of BC: $[4, -2, 6]$. Thus DR's of AB, AC, BC are same. Hence A, B, C are collinear.

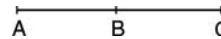

Example 4: Find the coordinates of the foot of the perpendicular from $A(1, 1, 1)$ on the line joining $B(1, 4, 6)$ and $C(5, 4, 4)$.

Solution: Suppose D divides BC in the ratio $k : 1$. Then the coordinates of D are $(\frac{5k+1}{k+1}, \frac{4k+4}{k+1}, \frac{4k+6}{k+1})$. DR's of AD: $\frac{4k}{k+1}, 3, \frac{3k+5}{k+1}$, DR's of BC: $4, 0, -2$ AD is \perp^r BC: $16k - 6k - 10 = 0$, or $k = 1$.

ANALYTICAL SOLID GEOMETRY — 3.5

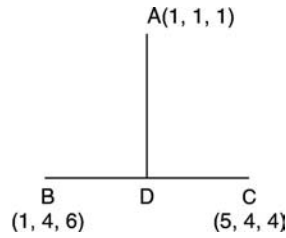

Coordinates of the foot of perpendicular are (3, 4, 5).

Example 5: Show that the points $A(1, 0, 2)$, $B(3, -1, 3)$, $C(2, 2, 2)$, $D(0, 3, 1)$ are the vertices of a parallelogram.

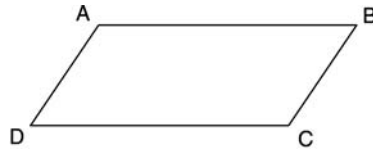

Fig. 3.7

Solution: DR's of AB are $[3 - 1, -1 - 0, 3 - 2] = [2, -1, 1]$. Similarly, DR's of BC are $[-1, 3, -1]$, of $CD[-2, 1, -1]$ of $DA[-1, 3, -1]$. Since DR's of AB and CD are same, they are parallel. Similarly BC and DA are parallel since DR's are same. Further AB is not \perp^r to AD because

$$2(+1) + (-1)(-3) + 1(+1) = 6 \neq 0$$

Similarly, AD is not \perp^r to BC because

$$2(-1) + (-1)3 + 1(-1) = -6 \neq 0.$$

Hence $ABCD$ is a parallelogram.

EXERCISE

- Show that the points $A(7, 0, 10)$, $B(6, -1, 6)$, $C(9, -4, 6)$ form an isoscales right angled triangle.

Hint: $AB^2 = BC^2 = 18$, $CA^2 = 36$, $AB^2 + BC^2 = CA^2$

- Prove that the points $A(3, -1, 1)$, $B(5, -4, 2)$, $C(11, -13, 5)$ are collinear.

Hint 1: $AB^2 = 14$, $BC^2 = 126$, $CA^2 = 224$, $AB + BC = 4\sqrt{14} = CA$

Hint 2: DR's of $AB = 2, -3, 1$; $BC: 6, -9, 3$; $AB \parallel^l$ to BC

- Determine the internal angles of the triangle ABC where $A(2, 3, 5)$, $B(-1, 3, 2)$, $C(3, 5, -2)$.

Hint: $AB^2 = 18$, $BC^2 = 36$, $AC^2 = 54$. DC's $AB: -\frac{1}{\sqrt{2}}, 0, -\frac{1}{\sqrt{2}}$; $BC: \frac{2}{3}, \frac{1}{3}, \frac{-2}{3}$; $AC: \frac{1}{3\sqrt{6}}, \frac{2}{3\sqrt{6}}, \frac{-7}{3\sqrt{6}}$.

Ans. $\cos A = \frac{1}{\sqrt{3}}$, $\cos B = 0$ i.e., $B = 90^\circ$, $\cos C = \frac{\sqrt{6}}{3}$.

- Show that the foot of the perpendicular from $A(0, 9, 6)$ on the line joining $B(1, 2, 3)$ and $C(7, -2, 5)$ is $D(-2, 4, 2)$.

Hint: D divides BC in $k : 1$, $D\left(\frac{7k+1}{k+1}, \frac{-2k+2}{k+1}, \frac{5k+3}{k+1}\right)$. DR's $AD: (7k + 1, -11k - 7, -k - 3)$, DR's $BC: 6, -4, 2$. $AD \perp^r BC: k = -\frac{1}{3}$.

- Find the condition that three lines with DC's $l_1, m_1, n_1; l_2, m_2, n_2; l_3, m_3, n_3$ are concurrent.

Hint: Line with DC's l, m, n through point of concurrency will be \perp^r to all three lines, $ll_i + mm_i + nn_i = 0, i = 1, 2, 3$.

Ans.
$$\begin{vmatrix} l_1 & m_1 & n_1 \\ l_2 & m_2 & n_2 \\ l_3 & m_3 & n_3 \end{vmatrix} = 0$$

- Show that $\cos^2 \alpha + \cos^2 \beta + \cos^2 \gamma + \cos^2 \delta = \frac{4}{3}$ where $\alpha, \beta, \gamma, \delta$ are the angles which a line makes with the four diagonals of a cube.

Hint: DC's of four diagonals are (k, k, k) , $(-k, k, k)$, $(k, -k, k)$, $(k, k, -k)$ where $k = \frac{1}{\sqrt{3}}$; l, m, n are DC's of line. $\cos \alpha = l.k$. $+mk + nk$, $\cos \beta = (-l + m + n)k$, $\cos \gamma = (l - m + n)k$, $\cos \delta = (l + m - n)k$.

- Show that the points $A(-1, 1, 3)$, $B(1, -2, 4)$, $C(4, -1, 1)$ are vertices of a right triangle.

Hint: DR's $AB : [2, -3, 1]$, $BC : [3, 1, -3]$, $CA : [5, -2, -2]$. AB is $\perp^r BC$.

3.6 — ENGINEERING MATHEMATICS

8. Prove that $A(3, 1, -2)$, $B(3, 0, 1)$, $C(5, 3, 2)$, $D(5, 4, -1)$ form a rectangle.

Hint: DR's: $AB: [0, -1, 3]$; $AC: [2, 2, 4]$, $CD[0, 1, -3]$; $AD[2, 3, 1]$; $BC[2, 3, 1]$; $AB \parallel CD, AD \parallel BC, AD \perp AB: 0 - 3 + 3 = 0$, $BC \perp DC: 0 + 3 - 3 = 0$.

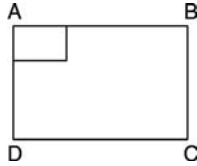

9. Find the interior angles of the triangle

$A(3, -1, 4)$, $B(1, 2, -4)$, $C(-3, 2, 1)$.

Hint: DC's of $AB: (-2, 3, -8)k_1$, $BC: (-4, 0, 5)k_2$, $AC: (-6, 3, -3)k_3$ where $k_1 = \frac{1}{\sqrt{77}}$, $k_2 = \frac{1}{\sqrt{41}}$, $k_3 = \frac{1}{\sqrt{54}}$.

Ans. $\cos A = \frac{15}{\sqrt{462}}$, $\cos B = \frac{32}{\sqrt{3157}}$, $\cos C = \frac{3}{\sqrt{246}}$.

10. Determine the DC's of a line \perp^r to a triangle formed by $A(2, 3, 1)$, $B(6, -3, 2)$, $C(4, 0, 3)$.

Ans. $(3, 2, 0)k$ where $k = \frac{1}{\sqrt{13}}$.

Hint: DR: $AB: [4, -6, 1]$, $BC: [-2, 3, 1]$, $CA: [2, -3, 2]$. $[a, b, c]$ of \perp^r line: $4a - 6b + c = 0$, $-2a + 3b + c = 0$, $2a - 3b + 2c = 0$.

3.3 THE PLANE

Surface is the locus of a point moving in space satisfying a single condition.

Example: Surface of a sphere is the locus of a point that moves at a constant distance from a fixed point.

Surfaces are either plane or curved. Equation of the locus of a point is the analytical expression of the given condition(s) in terms of the coordinates of the point.

Exceptional cases: Equations may have locus other than a surface. Examples: (i) $x^2 + y^2 = 0$ is z-axis (ii) $x^2 + y^2 + z^2 = 0$ is origin (iii) $y^2 + 4 = 0$ has no locus.

Plane is a surface such that the straight line PQ , joining any two points P and Q on the plane, lies completely on the plane.

General equation of first degree in x, y, z is of the form

$$Ax + By + Cz + D = 0$$

Here A, B, C, D are given real numbers and A, B, C are not all zero (i.e., $A^2 + B^2 + C^2 \neq 0$)

Book Work: Show that every equation of the first degree in x, y, z represents a plane.

Proof: Let

$$Ax + By + Cz + D = 0 \quad (1)$$

be the equation of first degree in x, y, z with the condition that not all A, B, C are zero (i.e., $A^2 + B^2 + C^2 \neq 0$). Let $P(x_1, y_1, z_1)$ and $Q(x_2, y_2, z_2)$ be any two points on the surface represented by (1). Then

$$Ax_1 + By_1 + Cz_1 + D_1 = 0 \quad (2)$$

$$Ax_2 + By_2 + Cz_2 + D_2 = 0 \quad (3)$$

Multiplying (3) by k and adding to (2), we get

$$A(x_1 + kx_2) + B(y_1 + ky_2) + C(z_1 + kz_2) + D(1 + k) = 0 \quad (4)$$

Assuming that $1 + k \neq 0$, divide (4) by $(1 + k)$.

$$A \left(\frac{x_1 + kx_2}{1 + k} \right) + B \left(\frac{y_1 + ky_2}{1 + k} \right) + C \left(\frac{z_1 + kz_2}{1 + k} \right) + D = 0$$

i.e., the point $R \left(\frac{x_1 + kx_2}{1 + k}, \frac{y_1 + ky_2}{1 + k}, \frac{z_1 + kz_2}{1 + k} \right)$ which is point dividing the line PQ in the ratio $k : 1$, also lies on the surface (1). Thus any point on the line joining P and Q lies on the surface i.e., line PQ completely lies on the surface. Therefore the surface by definition must be a plane.

General form of the equation of a plane is

$$Ax + By + Cz + D = 0$$

Special cases:

- (i) Equation of plane passing through origin is

$$Ax + By + Cz = 0 \quad (5)$$

ANALYTICAL SOLID GEOMETRY — 3.7

- (ii) Equations of the coordinate planes XOY, YOZ and ZOX are respectively $z = 0, x = 0$ and $y = 0$
- (iii) $Ax + By + D = 0$ plane \perp^r to xy -plane
 $Ax + Cz + D = 0$ plane \perp^r to xz -plane
 $Ay + Cz + D = 0$ plane \perp^r to yz -plane.

Similarly, $Ax + D = 0$ is \parallel^l to yz -plane, $By + D = 0$ is \parallel^l to xz -plane, $Cz + D = 0$ is \parallel^l to xy -plane.

One point form

Equation of a plane through a fixed point $P_1(x_1, y_1, z_1)$ and whose normal CD has DC's proportional to (A, B, C) : For any point $P(x, y, z)$ on the given plane, the DR's of the line P_1P are $(x - x_1, y - y_1, z - z_1)$. Since a line perpendicular to a plane is perpendicular to every line in the plane, so ML is perpendicular to P_1, P . Thus

$$A(x - x_1) + B(y - y_1) + C(z - z_1) = 0 \quad (6)$$

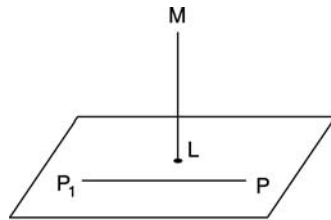

Fig. 3.8

Note 1: Rewriting (6), we get the general form of plane

$$Ax + By + Cz + D = 0 \quad (1)$$

where $D = -ax_1 - by_1 - cz_1$

Note 2: The real numbers A, B, C which are the coefficients of x, y, z respectively in (1) are proportional to DC's of the normal of the plane (1).

Note 3: Equation of a plane parallel to plane (1) is

$$Ax + By + Cz + D^* = 0 \quad (7)$$

x -intercept of a plane is the point where the plane cuts the x -axis. This is obtained by putting $y = 0,$

$z = 0$. Similarly, y -, z -intercepts. Traces of a plane are the lines of intersection of plane with coordinate axis.

Example: xy -trace is obtained by putting $z = 0$ in equation of plane.

Intercept form

Suppose $P(a, 0, 0), Q(0, b, 0), R(0, 0, c)$ are the x -, y -, z -intercepts of the plane. Then P, Q, R lies on the plane. From (1)

$$Aa + 0 + 0 + D = 0$$

or
$$A = -\frac{D}{a}.$$

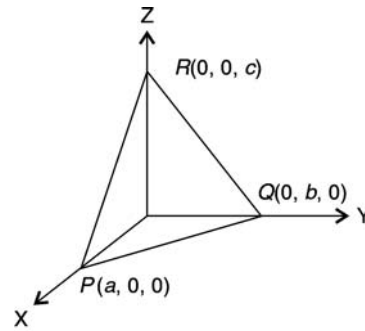

Fig. 3.9

similarly, $0 + bB + 0 + D = 0$ or $B = -\frac{D}{b}$ and $C = -\frac{D}{c}$.

Eliminating A, B, C the equation of the plane in the intercept form is

$$-\frac{D}{a}x - \frac{D}{b}y - \frac{D}{c}z + D = 0$$

or
$$\frac{x}{a} + \frac{y}{b} + \frac{z}{c} = 1 \quad (8)$$

Normal form

Let $P(x, y, z)$ be any point on the plane. Let ON be the perpendicular from origin O to the given plane. Let $ON = p$. (i.e., length of the perpendicular ON is p). Suppose l, m, n are the DC's of ON . Now ON is perpendicular to PN . Projection of OP on ON is ON itself i.e., p .

3.8 — ENGINEERING MATHEMATICS

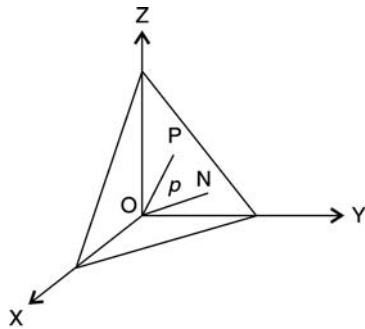

Fig. 3.10

Also the projection OP joining origin $(0, 0, 0)$ to $P(x, y, z)$ on the line ON with DC's l, m, n is

$$l(x - 0) + m(y - 0) + n(z - 0)$$

or $lx + my + nz$ (9)

Equating the two projection values from (8) & (9)

$$lx + my + nz = p$$
 (10)

Note 1: p is always positive, since p is the perpendicular distance from origin to the plane.

Note 2: Reduction from general form.

Transpose constant term to R.H.S. and make it positive (if necessary by multiplying throughout by -1). Then divide throughout by $\pm\sqrt{A^2 + B^2 + C^2}$. Thus the general form $Ax + By + Cz + D = 0$ takes the following normal form

$$\frac{Ax}{\pm\sqrt{A^2+B^2+C^2}} + \frac{By}{\pm\sqrt{A^2+B^2+C^2}} + \frac{Cz}{\pm\sqrt{A^2+B^2+C^2}} = \frac{-D}{\pm\sqrt{A^2 + B^2 + C^2}}$$
 (11)

The sign before the radical is so chosen to make the R.H.S. in (11) positive.

Three point form

Equation of a plane passing through three given points $P_1(x_1, y_1, z_1), P_2(x_2, y_2, z_2), P_3(x_3, y_3, z_3)$:

Since the three points P_1, P_2, P_3 lie on the plane

$$Ax + By + Cz + D = 0$$
 (1)

we have $Ax_1 + By_1 + Cz_1 + D = 0$ (2)

$$Ax_2 + By_2 + Cz_2 + D = 0$$
 (3)

$$Ax_3 + By_3 + Cz_3 + D = 0$$
 (4)

Eliminating A, B, C, D from (1), (2), (3), (4) (i.e., a non trivial solution A, B, C, D for the homogeneous system of 4 equations exist if the determinant coefficient is zero)

$$\begin{vmatrix} x & y & z & 1 \\ x_1 & y_1 & z_1 & 1 \\ x_2 & y_2 & z_2 & 1 \\ x_3 & y_3 & z_3 & 1 \end{vmatrix} = 0$$
 (15)

Equation (15) is the required equation of the plane through the 3 points P_1, P_2, P_3 .

Corollary 1: Coplanarity of four given points:

The four points $P_1(x_1, y_1, z_1), P_2(x_2, y_2, z_2), P_3(x_3, y_3, z_3), P_4(x_4, y_4, z_4)$ are coplanar (lie in a plane) if

$$\begin{vmatrix} x_1 & y_1 & z_1 & 1 \\ x_2 & y_2 & z_2 & 1 \\ x_3 & y_3 & z_3 & 1 \\ x_4 & y_4 & z_4 & 1 \end{vmatrix} = 0$$
 (16)

Angle between Two Given Planes

The angle between two planes

$$A_1x + B_1y + C_1z + D_1 = 0$$
 (17)

$$A_2x + B_2y + C_2z + D_2 = 0$$
 (18)

is the angle θ between their normals. Here A_1, B_1, C_1 and A_2, B_2, C_2 are the DR's of the normals respectively to the planes (17) and (18). Then

$$\cos \theta = \frac{A_1A_2 + B_1B_2 + C_1C_2}{\sqrt{A_1^2 + B_1^2 + C_1^2}\sqrt{A_2^2 + B_2^2 + C_2^2}}$$

Condition for perpendicularity

If $\theta = 90^\circ$ then the two planes are \perp to each other. Then

$$A_1A_2 + B_1B_2 + C_1C_2 = 0$$
 (19)

Condition for parallelism

If $\theta = 0$, the two planes are \parallel to each other. Then

$$\frac{A_1}{A_2} = \frac{B_1}{B_2} = \frac{C_1}{C_2}$$
 (20)

Note: Thus parallel planes differ by a constant.

Although there are four constants A, B, C, D in the equation of plane, essentially three conditions are

ANALYTICAL SOLID GEOMETRY — 3.9

required to determine the three ratios of A, B, C, D , for example plane passing through:

- a. three non-collinear points
- b. two given points and \perp^r to a given plane
- c. a given point and \perp^r to two given planes etc.

Coordinate of the Foot of the Perpendicular from a Point to a Given Plane

Let $Ax + By + Cz + D = 0$ be the given plane and $P(x_1, y_1, z_1)$ be a given point. Let PN be the perpendicular from P to the plane. Let the coordinates of the foot of the perpendicular PN be $N(\alpha, \beta, \gamma)$. Then DR's of $PN(x_1 - \alpha, y_1 - \beta, z_1 - \gamma)$ are proportional to the coefficients A, B, C i.e.,

$$\begin{aligned} x_1 - \alpha &= kA, & y_1 - \beta &= kB, & z_1 - \gamma &= kC \\ \text{or } \alpha &= x_1 - kA, & \beta &= y_1 - kB, & \gamma &= z_1 - kC \end{aligned}$$

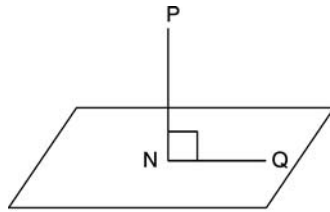

Fig. 3.11

Since N lies in the plane

$$A\alpha + B\beta + C\gamma + D = 0$$

Substituting α, β, γ ,

$$A(x_1 - kA) + b(y_1 - kB) + c(z_1 - kC) + D = 0$$

$$\text{Solving } k = \frac{Ax_1 + By_1 + Cz_1 + D}{A^2 + B^2 + C^2}$$

Thus the coordinates of $N(\alpha, \beta, \gamma)$ the foot of the perpendicular from $P(x_1, y_1, z_1)$ to the plane are

$$\begin{aligned} \alpha &= x_1 - \frac{A(Ax_1 + By_1 + Cz_1 + D)}{A^2 + B^2 + C^2}, \\ \beta &= y_1 - \frac{B(Ax_1 + By_1 + Cz_1 + D)}{A^2 + B^2 + C^2}, \\ \gamma &= z_1 - \frac{C(Ax_1 + By_1 + Cz_1 + D)}{A^2 + B^2 + C^2} \end{aligned} \quad (21)$$

Corollary 1: Length of the perpendicular from a given point to a given plane:

$$\begin{aligned} PN^2 &= (x_1 - \alpha)^2 + (y_1 - \beta)^2 + (z_1 - \gamma)^2 \\ &= (kA)^2 + (kB)^2 + (kC)^2 \end{aligned}$$

$$\begin{aligned} &= k^2(A^2 + B^2 + C^2) \\ &= \left[\frac{Ax_1 + By_1 + Cz_1 + D}{A^2 + B^2 + C^2} \right]^2 (A^2 + B^2 + C^2) \\ &= \frac{(Ax_1 + By_1 + Cz_1 + D)^2}{A^2 + B^2 + C^2} \end{aligned}$$

$$\text{or } PN = \frac{Ax_1 + By_1 + Cz_1 + D}{\pm\sqrt{A^2 + B^2 + C^2}}$$

The sign before the radical is chosen as positive or negative according as D is positive or negative. Thus the numerical values of the length of the perpendicular PN is

$$PN = \left| \frac{Ax_1 + By_1 + Cz_1 + D}{\sqrt{A^2 + B^2 + C^2}} \right| \quad (22)$$

Note: PN is obtained by substituting the coordinates (x_1, y_1, z_1) in the L.H.S. of the Equation (1) and dividing it by $\sqrt{A^2 + B^2 + C^2}$.

Equation of a plane passing through the line of intersection of two given planes $u \equiv A_1x + B_1y + C_1z + D_1 = 0$ and $v \equiv A_2x + B_2y + C_2z + D_2 = 0$ is $u + kv = 0$ where k is any constant.

Equations of the two planes bisecting the angles between two planes are

$$\frac{A_1x + B_1y + C_1z + D_1}{\sqrt{A_1^2 + B_1^2 + C_1^2}} = \pm \frac{A_2x + B_2y + C_2z + D_2}{\sqrt{A_2^2 + B_2^2 + C_2^2}}$$

WORKED OUT EXAMPLES

Example 1: Find the equation of the plane which passes through the point $(2, 1, 4)$ and is

- a. Parallel to plane $2x + 3y + 5z + 6 = 0$
- b. Perpendicular to the line joining $(3, 2, 5)$ and $(1, 6, 4)$
- c. Perpendicular to the two planes $7x + y + 2z = 6$ and $3x + 5y - 6z = 8$
- d. Find intercept points and traces of the plane in case c.

Solution:

- a. Any plane parallel to the plane $2x + 3y + 5z + 6 = 0$

3.10 — ENGINEERING MATHEMATICS

is given by $2x + 3y + 5z + k = 0$ (1) (differs by a constant). Since the point $(2, 1, 4)$ lies on the plane (1), $2(2) + 3(1) + 5(4) + k = 0$, $k = -27$. Required equation of plane is $2x + 3y + 5z - 27 = 0$.

- b. Any plane through the point $(2, 1, 4)$ is (one point form)

$$A(x - 2) + B(y - 1) + C(z - 4) = 0 \quad (2)$$

DC's of the line joining $M(3, 2, 5)$ and $N(1, 6, 4)$ are proportional to $2, -4, 1$. Since MN is perpendicular to (2), A, B, C are proportional to $2, -4, 1$. Then $2(x - 2) - 4(y - 1) + 1(z - 4) = 0$. The required equation of plane is $2x - 4y + z - 4 = 0$.

- c. The plane through $(2, 1, 4)$ is

$$A(x - 2) + B(y - 1) + C(z - 4) = 0. \quad (2)$$

This plane (2) is perpendicular to the two planes $7x + y + 2z = 6$ and $3x + 5y - 6z = 8$. Using $A_1A_2 + B_1B_2 + C_1C_2 = 0$, we have

$$7a + b + 2c = 0$$

$$3a + 5b - 6c = 0$$

Solving $\frac{a}{-6-10} = \frac{-b}{-42-8} = \frac{c}{35-3}$ or $\frac{a}{1} = \frac{b}{-3} = \frac{c}{-2}$.

Required equation of plane is

$$1(x - 4) - 3(y - 1) - 2(z - 4) = 0$$

or
$$x - 3y - 2z + 7 = 0$$

- d. x -intercept: Put $y = z = 0$, $\therefore x = -7$ or $(-7, 0, 0)$ is the x -intercept. Similarly, y -intercept is $(0, \frac{7}{3}, 0)$ and z -intercept is $(0, 0, \frac{7}{2})$. xy -trace is obtained by putting $z = 0$. It is $x - 3y + 7 = 0$. Similarly, yz -trace is $3y + 2z - 7 = 0$ and zx -trace is $x - 2z + 7 = 0$.

Example 2: Find the equation of the plane containing the points $P(3, -1, -4)$, $Q(-2, 2, 1)$, $R(0, 4, -1)$.

Solution: Equation of plane through the point $P(3, -1, -4)$ is

$$A(x + 3) + B(y + 1) + C(z + 4) = 0. \quad (1)$$

DR's of PQ : $-5, 3, 5$; DR's of PR : $-3, 5, 3$. Since line PQ and PR completely lies in the plane (1), normal to (1) is perpendicular to PQ and PR . Then

$$-5A + 3B + 5C = 0$$

$$-3A + 5B + 3C = 0$$

Solving $A = C = 1, \quad B = 0$

$$(x - 3) + 0 + (z + 4) = 0$$

Equation of the plane is

$$x + z + 1 = 0$$

Aliter: Equation of the plane by 3-point form is

$$\begin{vmatrix} x & y & z & 1 \\ 3 & -1 & -4 & 1 \\ -2 & 2 & 1 & 1 \\ 0 & 4 & -1 & 1 \end{vmatrix} = 0$$

Expanding $D_1x - D_2y + D_3z - 1.D_4 = 0$ where

$$D_1 = \begin{vmatrix} -1 & -4 & 1 \\ 2 & 1 & 1 \\ 4 & -1 & 1 \end{vmatrix} = -16, \quad D_2 = \begin{vmatrix} 3 & -4 & 1 \\ -2 & 1 & 1 \\ 0 & -1 & 1 \end{vmatrix} = 0$$

$$D_3 = \begin{vmatrix} 3 & -1 & 1 \\ -2 & 2 & 1 \\ 0 & 4 & 1 \end{vmatrix} = -16, \quad D_4 = \begin{vmatrix} 3 & -1 & -4 \\ -2 & 2 & 1 \\ 0 & 4 & -1 \end{vmatrix} = 16$$

or required equation is $x + z + 1 = 0$.

Example 3: Find the perpendicular distance between (a) The Point $(3, 2, -1)$ and the plane $7x - 6y + 6z + 8 = 0$ (b) between the parallel planes $x - 2y + 2z - 8 = 0$ and $x - 2y + 2z + 19 = 0$ (c) find the foot of the perpendicular in case (a).

Solution:

$$\text{Perpendicular distance} = \left(\frac{Ax_1 + By_1 + Cz_1 + D}{\sqrt{A^2 + B^2 + C^2}} \right)$$

- a. Point $(3, 2, -1)$, plane is $7x - 6y + 6z + 8 = 0$. So perpendicular distance from $(3, 2, -1)$ to plane is

$$= \frac{7(3) - 6(2) + 6(-1) + 8}{\sqrt{7^2 + 6^2 + 6^2}} = \frac{11}{-11} = |-1| = 1$$

- b. x -intercept point of plane $x - 2y + 2z - 8 = 0$ is $(8, 0, 0)$ (obtained by putting $y = 0, z = 0$ in the equation). Then perpendicular distance from

ANALYTICAL SOLID GEOMETRY — 3.11

the point (8, 0, 0) to the second plane $x - 2y + 2z + 19 = 0$ is $\frac{1 \cdot 8 - 2 \cdot 0 + 2 \cdot 0 + 19}{\sqrt{1^2 + 2^2 + 2^2}} = \frac{27}{3} = 9$

c. Let $N(\alpha, \beta, \gamma)$ be the foot of the perpendicular from $P(3, 2, -1)$. DR's of PN: $3 - \alpha, 2 - \beta, -1 - \gamma$. DR's of normal to plane are 7, -6, 6. These are proportional. $\frac{3-\alpha}{7} = \frac{2-\beta}{-6} = \frac{-1-\gamma}{6}$ or $\alpha = 3 - 7k, \beta = 2 + 6k, \gamma = -1 - 6k$. Now (α, β, γ) lies on the plane. $7(3 - 7k) - 6(2 + 6k) + 6(-1 - 6k) + 8 = 0$ or $k = \frac{1}{11}$. \therefore the coordinates of the foot of perpendicular are $(\frac{26}{11}, \frac{28}{11}, \frac{-17}{11})$.

Example 4: Are the points (2, 3, -5) and (3, 4, 7) on the same side of the plane $x + 2y - 2z = 9$?

Solution: Perpendicular distance of the point (2, 3, -5) from the plane $x + 2y - 2z - 9 = 0$ or $-x - 2y + 2z + 9 = 0$ is $\frac{-1 \cdot 2 - 2 \cdot 3 - 2 \cdot (-5) + 9}{\sqrt{1^2 + 2^2 + 2^2}} = -\frac{9}{3} = -3$.

\perp^r distance of (3, 4, 7) is $\frac{-1 \cdot 3 - 2 \cdot 4 + 2 \cdot 7 + 9}{\sqrt{1^2 + 2^2 + 2^2}} = \frac{12}{3} = 6$

\perp^r distance from origin (0, 0, 0) is $\frac{0 + 0 + 0 + 9}{3} = 3$

So points (2, 3, -5) and (3, 4, 7) are on opposite sides of the given plane.

Example 5: Find the angle between the planes $4x - y + 8z = 9$ and $x + 3y + z = 4$.

Solution: DR's of the planes are [4, -1, 8] and [1, 3, 1]. Now

$$\begin{aligned} \cos \theta &= \frac{A_1 A_2 + B_1 B_2 + C_1 C_2}{\sqrt{A_1^2 + B_1^2 + C_1^2} \sqrt{A_2^2 + B_2^2 + C_2^2}} \\ &= \frac{4 \cdot 1 + 3 \cdot (-1) + 8 \cdot 1}{\sqrt{16 + 1 + 64} \sqrt{1 + 9 + 1}} \\ &= \frac{9}{\sqrt{81} \sqrt{11}} = \frac{1}{\sqrt{11}} \quad \text{or} \quad \theta = \cos^{-1} \frac{1}{\sqrt{11}} \end{aligned}$$

Example 6: Find the equation of a plane passing through the line of intersection of the planes.

a. $3x + y - 5z + 7 = 0$ and $x - 2y + 4z - 3 = 0$ and passing through the point (-3, 2, -4)

b. $2x - 5y + z = 3$ and $x + y + 4z = 5$ and parallel to the plane $x + 3y + 6z = 1$.

Solution:

a. Equation of plane is $u + kv = 0$ i.e.,

$$(3x + y - 5z + 7) + k(x - 2y + 4z - 3) = 0.$$

Since point (-3, 2, -4) lies on the intersection plane

$$\begin{aligned} [3(-3) + 1 \cdot (2) - 5(-4) + 7] \\ + k[1(-3) - 2(2) + 4(-4) - 3] = 0. \end{aligned}$$

So $k = \frac{10}{13}$. Then the required plane is

$$49x - 7y - 25z + 61 = 0.$$

b. Equation of plane is $u + kv = 0$ i.e.,

$$(2x - 5y + z - 3) + k(x + y + 4z - 5) = 0$$

$$\text{or } (2+k)x + (-5+k)y + (1+4k)z + (-3-5k) = 0.$$

Since this intersection plane is parallel to $x + 3y + 6z - 1 = 0$

$$\text{So } \frac{2+k}{1} = \frac{-5+k}{3} = \frac{1+4k}{6} \quad \text{or} \quad k = -\frac{11}{2}.$$

Required equation of plane is $7x + 21y + 42z - 49 = 0$.

Example 7: Find the planes bisecting the angles between the planes $x + 2y + 2z = 9$ and $4x - 3y + 12z + 13 = 0$. Specify the angle θ between them.

Solution: Equations of the bisecting planes are

$$\frac{x + 2y + 2z - 9}{\sqrt{1 + 2^2 + 2^2}} = \pm \frac{4x - 3y + 12z + 13}{\sqrt{4^2 + 3^2 + 12^2}}$$

$$\frac{x + 2y + 2z - 9}{3} = \pm \frac{4x - 3y + 12z + 13}{13}$$

$$\text{or } 25x + 17y + 62z - 78 = 0 \quad \text{and}$$

$$x + 35y - 10z - 156 = 0.$$

$$\cos \theta = \frac{25 \cdot 1 + 17 \cdot 35 - 62 \times 10}{\sqrt{25^2 + 17^2 + 62^2} \sqrt{1 + 35^2 + 10^2}} = 0$$

$$\therefore \theta = \frac{\pi}{2}$$

i.e., angle between the bisecting planes is $\frac{\pi}{2}$.

3.12 — ENGINEERING MATHEMATICS

Example 8: Show that the planes

$$7x + 4y - 4z + 30 = 0 \quad (1)$$

$$36x - 51y + 12z + 17 = 0 \quad (2)$$

$$14x + 8y - 8z - 12 = 0 \quad (3)$$

$$12x - 17y + 4z - 3 = 0 \quad (4)$$

form four faces of a rectangular parallelepiped.

Solution: (1) and (3) are parallel since $\frac{7}{14} = \frac{4}{8} = \frac{-4}{-8} = \frac{1}{2}$. (2) and (4) are parallel since $\frac{36}{12} = \frac{-51}{-17} = \frac{12}{4} = 3$. Further (1) and (2) are \perp^r since

$$7 \cdot 36 + 4(-51) - 4(12) = 252 - 204 - 48 = 0.$$

EXERCISE

- Find the equation of the plane through $P(4, 3, 6)$ and perpendicular to the line joining $P(4, 3, 6)$ to the point $Q(2, 3, 1)$.

Hint: DR's PQ: $[2, 0, 5]$, DR of plane through $(4, 3, 6)$: $x - 4, y - 3, z - 6$; \perp^r : $2(x - 4) + 0(y - 3) + 5(z - 6) = 0$

Ans. $2x + 5z - 38 = 0$

- Find the equation of the plane through the point $P(1, 2, -1)$ and parallel to the plane $2x - 3y + 4z + 6 = 0$.

Hint: Eq. $2x - 3y + 4z + k = 0$, $(1, 2, -1)$ lies, $k = 8$.

Ans. $2x - 3y + 4z + 8 = 0$

- Find the equation of the plane that contains the three points $P(1, -2, 4)$, $Q(4, 1, 7)$, $R(-1, 5, 1)$.

Hint: $A(x - 1) + B(y + 2) + C(z - 4) = 0$, DR: $PQ: [3, 3, 3]$, $PR: [-2, 7, -3]$. \perp^r $3A + 3B + 3C = 0$, $-2A + 7B - 3C = 0$, $A = -10B$, $C = 9B$.

Aliter:
$$\begin{vmatrix} x & y & z & 1 \\ 1 & -2 & 4 & 1 \\ 4 & 1 & 7 & 1 \\ -1 & 5 & 1 & 1 \end{vmatrix} = 0,$$

$$D_1x - D_2y + D_3z - D_4 = 0$$

where
$$D_1 = \begin{vmatrix} -2 & 4 & 1 \\ 1 & 7 & 1 \\ 5 & 1 & 1 \end{vmatrix} \text{ etc.}$$

Ans. $10x - y - 9z + 24 = 0$

- Find the equation of the plane
 - passing through $(1, -1, 2)$ and \perp^r to each of the planes $2x + 3y - 2z = 5$ and $x + 2y - 3z = 8$
 - passing through $(-1, 3, -5)$ and parallel to the plane $6x - 3y - 2z + 9 = 0$
 - passing through $(2, 0, 1)$ and $(-1, 2, 0)$ and \perp^r to the plane $2x - 4y - z = 7$.

Ans. a. $5x - 4y - z = 7$

b. $6x - 3y - 2z + 5 = 0$

c. $6x + 5y - 8z = 4$

- Find the perpendicular distance between
 - the point $(-2, 8, -3)$ and plane $9x - y - 4z = 0$
 - the two planes $x - 2y + 2z = 6$, $3x - 6y + 6z = 2$
 - the point $(1, -2, 3)$ and plane $2x - 3y + 2z - 14 = 0$.

Ans. (a) $\sqrt{2}$ (b) $\frac{-16}{9}$ (c) 0 i.e., lies on the plane.

- Find the angle between the two planes
 - $x + 4y - z = 5$, $y + z = 2$
 - $x - 2y + 3z + 4 = 0$, $2x + y - 3z + 7 = 0$

Ans. (a) $\cos \theta = \frac{1}{2}$, $\theta = 60^\circ$ (b) $\cos \theta = \frac{-9}{14}$.

- Prove that the planes $5x - 3y + 4z = 1$, $8x + 3y + 5z = 4$, $18x - 3y + 13z = 6$ contain a common line.

Hint: $u + kv = 0$ substitute in $w = 0$, $k = \frac{1}{2}$

- Find the coordinates of N , the foot of the perpendicular from the point $P(-3, 0, 1)$ on the plane $4x - 3y + 2z = 19$. Find the length of this perpendicular. Find also the image of P in the plane.

Hint: $PN = NQ$ i.e., N is the mid point.

Ans. $N(1, -3, 3)$, $\sqrt{29}$, image of P is $Q(5, -6, 5)$

- Find the equation of the plane through the line of intersection of the two planes $x - 3y + 5z - 7 = 0$ and $2x + y - 4z + 1 = 0$ and \perp^r to the plane $x + y - 2z + 4 = 0$.

ANALYTICAL SOLID GEOMETRY — 3.13

Ans. $3x - 2y + z - 6 = 0$

10. A variable plane passes through the fixed point (a, b, c) and meets the coordinate axes in P, Q, R . Prove that the locus of the point common to the planes through P, Q, R parallel to the coordinate plane is $\frac{a}{x} + \frac{b}{y} + \frac{c}{z} = 1$.

Hint: $OP = x_1, OQ = y_1, OR = z_1, \frac{x}{x_1} + \frac{y}{y_1} + \frac{z}{z_1} = 1, (a, b, c)$ lies, $\frac{a}{x_1} + \frac{b}{y_1} + \frac{c}{z_1} = 1$.

3.4 THE STRAIGHT LINE

Two surfaces will in general intersect in a curve. In particular two planes, which are not parallel, intersect in a straight line.

Example: The coordinate planes ZOX and XOY , whose equations are $y = 0$ and $z = 0$ respectively, intersect in a line the x -axis.

Straight line

The locus of two simultaneous equations of first degree in x, y, z

$$\begin{aligned} A_1x + B_1y + C_1z + D_1 &= 0 \\ A_2x + B_2y + C_2z + D_2 &= 0 \end{aligned} \tag{1}$$

is a straight line, provided $A_1 : B_1 : C_1 \neq A_2 : B_2 : C_2$ (i.e., not parallel). Equation (1) is known as the **general form** of the equation of a straight line. Thus the equation of a straight line or simply line is the pair of equations taken together i.e., equations of two planes together represent the equation of a line. However this representation is not unique, because many planes can pass through a given line. Thus a given line can be represented by different pairs of first degree equations.

Projecting planes

Of the many planes passing through a given line, those that are perpendicular to the coordinate planes are known as projecting planes and their traces give the **projections** of the line on the coordinate planes.

Symmetrical Form

The equation of line passing through a given point $P_1(x_1, y_1, z_1)$ and having direction cosines l, m, n is given by

$$\frac{x - x_1}{l} = \frac{y - y_1}{m} = \frac{z - z_1}{n} \tag{2}$$

since for any point $P(x, y, z)$ on the line, the DR's of PP_1 : $x - x_1, y - y_1, z - z_1$ be proportional to l, m, n . Equation (2) represent two independent linear equations and are called the symmetrical (or symmetric) form of the equation of a line.

Corollary: Any point P on the line (2) is given by

$$x = x_1 + lr, \quad y = y_1 + mr, \quad z = z_1 + nr \tag{3}$$

for different values of r , where $r = PP_1$.

Corollary: Lines perpendicular to one of the coordinate axes:

- a. $x = x_1, \frac{y - y_1}{m} = \frac{z - z_1}{n}$, (\perp^r to x -axis i.e., \parallel^l to yz -plane)
- b. $y = y_1, \frac{x - x_1}{l} = \frac{z - z_1}{n}$, (\perp^r to y -axis i.e., \parallel^l to xz -plane)
- c. $z = z_1, \frac{x - x_1}{l} = \frac{y - y_1}{m}$, (\perp^r to z -axis i.e., \parallel^l to xy -plane)

Corollary: Lines perpendicular to two axes

- a. $x = x_1, y = y_1$ (\perp^r to x - & y -axis i.e., \parallel^l to z -axis):
- b. $x = x_1, z = z_1$ (\perp^r to x - & z -axis i.e., \parallel^l to y -axis)
- c. $y = y_1, z = z_1$ (\perp^r to y - & z -axis i.e., \parallel^l to x -axis)

Corollary: Projecting planes: (containing the given line)

(a) $\frac{x - x_1}{l} = \frac{y - y_1}{m}$ (b) $\frac{x - x_1}{l} = \frac{z - z_1}{n}$ (c) $\frac{y - y_1}{m} = \frac{z - z_1}{n}$.

Note: When any of the constants l, m, n are zero, the Equation (2) are equivalent to equations

$$\frac{l}{x - x_1} = \frac{m}{y - y_1} = \frac{n}{z - z_1}.$$

3.14 — ENGINEERING MATHEMATICS

Example: $\frac{x}{0} = \frac{y}{2} = \frac{z}{0}$ means $\frac{0}{x} = \frac{2}{y} = \frac{0}{z}$.

Corollary: If a, b, c are the DR's of the line, then (2) takes the form $\frac{x-x_1}{a} = \frac{y-y_1}{b} = \frac{z-z_1}{c}$.

Corollary: **Two point form** of a line passing through two given points $P_1(x_1, y_1, z_1)$ and $P_2(x_2, y_2, z_2)$ is

$$\frac{x - x_1}{x_2 - x_1} = \frac{y - y_1}{y_2 - y_1} = \frac{z - z_1}{z_2 - z_1} \quad (4)$$

since the DR's of P_1P_2 are $x_2 - x_1, y_2 - y_1, z_2 - z_1$.

Transformation of General Form to Symmetrical Form

The general form also known as unsymmetrical form of the equation of a line can be transformed to symmetrical form by determining

- (a) one point on the line, by putting say $z = 0$ and solving the simultaneous equations in x and y .
- (b) the DC's of the line from the fact that this line is \perp^r to both normals of the given planes.

For example,

- (a) by putting $z = 0$ in the general form

$$\begin{aligned} A_1x + B_1y + C_1z + D_1 &= 0 \\ A_2x + B_2y + C_2z + D_2 &= 0 \end{aligned} \quad (2)$$

and solving the resulting equations

$$\begin{aligned} A_1x + B_1y + D_1 &= 0 \\ A_2x + B_2y + D_2 &= 0, \end{aligned}$$

we get a point on the line as

$$\left(\frac{B_1D_2 - B_2D_1}{A_1B_2 - A_2B_1}, \frac{A_2D_1 - A_1D_2}{A_1B_2 - A_2B_1}, 0 \right) \quad (5)$$

- (b) Using the orthogonality of the line with the two normals of the two planes, we get

$$\begin{aligned} lA_1 + mB_1 + nC_1 &= 0 \\ lA_2 + mB_2 + nC_2 &= 0 \end{aligned}$$

where $(l, m, n), (A_1, B_1, C_1)$ and (A_2, B_2, C_2) are DR's of the line, normal to first plane, normal to second plane respectively. Solving, we get the

DR's l, m, n of the line as

$$\frac{l}{B_1C_2 - B_2C_1} = \frac{m}{C_1A_2 - C_2A_1} = \frac{n}{A_1B_2 - A_2B_1} \quad (6)$$

Using (5) and (6), thus the given general form (2) of the line reduces to the symmetrical form

$$\begin{aligned} \frac{x - \frac{(B_2D_1 - B_1D_2)}{A_1B_2 - A_2B_1}}{B_1C_2 - B_2C_1} &= \frac{y - \frac{(A_2D_1 - A_1D_2)}{A_1B_2 - A_2B_1}}{C_1A_2 - C_2A_1} = \\ &= \frac{z - 0}{A_1B_2 - A_2B_1} \end{aligned} \quad (7)$$

Note 1: In finding a point on the line, one can put $x = 0$ or $y = 0$ instead of $z = 0$ and get similar results.

Note 2: General form (2) can also be reduced to the two point form (4) (special case of symmetric form) by determining two points on the line.

Angle between a Line and a Plane

Let π be the plane whose equation is

$$Ax + By + Cz + D = 0 \quad (8)$$

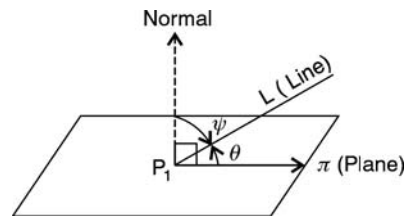

Fig. 3.12

and L be the straight line whose symmetrical form is

$$\frac{x - x_1}{l} = \frac{y - y_1}{m} = \frac{z - z_1}{n} \quad (2)$$

Let θ be the angle between the line L and the plane π . Let ψ be the angle between L and the normal to the plane π . Then

$$\begin{aligned} \cos \psi &= \frac{lA + mB + nC}{\sqrt{l^2 + m^2 + n^2} \sqrt{A^2 + B^2 + C^2}} \\ &= \cos(90 - \theta) = \sin \theta \end{aligned} \quad (9)$$

since $\psi = 90 - \theta$. The angle between a line L and plane π is the complement of the angle between the

ANALYTICAL SOLID GEOMETRY — 3.15

line L and the normal to the plane). Thus θ is determined from (9).

Corollary: Line is \parallel^l to the plane if $\theta = 0$ then $\sin \theta = 0$ i.e.,

$$\boxed{lA + mB + nC = 0} \quad (10)$$

Corollary: Line is \perp^r to the plane if $\theta = \frac{\pi}{2}$, then $\sin \theta = 1$ i.e.,

$$\boxed{\frac{l}{A} = \frac{m}{B} = \frac{n}{C}} \quad (11)$$

(i.e., DR's of normal and the line are same).

Conditions for a Line L to Lie in a Plane π

If every point of line L is a point of plane π , then line L lies in plane π . Substituting any point of the line $L : (x_1 + lr, y_1 + mr, z_1 + nr)$ in the equation of the plane (8), we get

$$A(x_1 + lr) + B(y_1 + mr) + C(z_1 + nr) + D = 0$$

or $(Al + Bm + Cn)r + (Ax_1 + By_1 + Cz_1 + D) = 0$ (12)

This Equation (12) is satisfied for all values of r if the coefficient of r and constant term in (12) are both zero i.e.,

$$\boxed{\begin{matrix} Al + Bm + Cn = 0 & \text{and} \\ Ax_1 + By_1 + Cz_1 + D = 0 \end{matrix}} \quad (13)$$

Thus the two conditions for a line L to lie in a plane π are given by (13) which geometrically mean that (i) line L is \perp^r to the normal of the plane and (ii) a (any one) point of line L lies on the plane.

Corollary: General equation of a plane containing line L (2) is

$$A(x - x_1) + B(y - y_1) + C(z - z_1) = 0 \quad (14)$$

subject to

$$Al + Bm + Cn = 0$$

Corollary: Equation of any plane through the line of intersection of the two planes

$$\begin{aligned} u &\equiv A_1x + B_1y + C_1z + D_1 = 0 & \text{and} \\ v &\equiv A_2x + B_2y + C_2z + D_2 = 0 \end{aligned}$$

is $u + kv = 0$ or $(A_1x + B_1y + C_1z + D_1) + k(A_2x + B_2y + C_2z + D_2) = 0$ where k is a constant.

Coplanar Lines

Consider two given straight lines L_1

$$\frac{x - x_1}{l_1} = \frac{y - y_1}{m_1} = \frac{z - z_1}{n_1} \quad (15)$$

and line L_2

$$\frac{x - x_2}{l_2} = \frac{y - y_2}{m_2} = \frac{z - z_2}{n_2} \quad (16)$$

From (14), equation of any plane containing line L_1 is

$$A(x - x_1) + B(y - y_1) + C(z - z_1) = 0 \quad (17)$$

subject to

$$Al_1 + Bm_1 + Cn_1 = 0 \quad (18)$$

If the plane (17) contains line L_2 also, then the point (x_2, y_2, z_2) of L_2 should also lie in the plane (17). Then

$$A(x_2 - x_1) + B(y_2 - y_1) + C(z_2 - z_1) = 0 \quad (19)$$

But the line L_2 is \perp^r to the normal to the plane (17). Thus

$$Al_2 + Bm_2 + Cn_2 = 0 \quad (20)$$

Therefore the two lines L_1 and L_2 will lie in the same plane if (17), (18), (20) are simultaneously satisfied. Eliminating A, B, C from (19), (18), (20) (i.e., homogeneous system consistent if coefficient determinant is zero), we have

$$\begin{vmatrix} x_2 - x_1 & y_2 - y_1 & z_2 - z_1 \\ l_1 & m_1 & n_1 \\ l_2 & m_2 & n_2 \end{vmatrix} = 0 \quad (21)$$

Thus (21) is the condition for coplanarity of the two lines L_1 and L_2 . Now the equation of the plane containing lines L_1 and L_2 is

$$\begin{vmatrix} x - x_1 & y - y_1 & z - z_1 \\ l_1 & m_1 & n_1 \\ l_2 & m_2 & n_2 \end{vmatrix} = 0 \quad (22)$$

which is obtained by eliminating A, B, C from (17), (18), (20).

3.16 — ENGINEERING MATHEMATICS

Corollary: Condition for the two lines L_1

$$\begin{aligned} u_1 &\equiv A_1x + B_1y + C_1z + D_1 = 0, \\ u_2 &\equiv A_2x + B_2y + C_2z + D_2 = 0 \end{aligned} \tag{23}$$

and Line L_2 $u_3 \equiv A_3x + B_3y + C_3z + D_3 = 0,$

$$u_4 \equiv A_4x + B_4y + C_4z + D_4 = 0$$

to be coplanar is

$$\begin{vmatrix} A_1 & B_1 & C_1 & D_1 \\ A_2 & B_2 & C_2 & D_2 \\ A_3 & B_3 & C_3 & D_3 \\ A_4 & B_4 & C_4 & D_4 \end{vmatrix} = 0 \tag{24}$$

If $P(\alpha, \beta, \gamma)$ is the point of intersection of the two lines, then P should satisfy the four Equations (23): u_i at $(\alpha, \beta, \gamma) = 0$ for $i = 1, 2, 3, 4$. Elimination of (α, β, γ) from these four equations leads to (24).

Corollary: The general form of equations of a line L_3 intersecting the lines L_1 and L_2 given by (23) are

$$u_1 + k_1u_2 = 0 \quad \text{and} \quad u_3 + k_2u_4 = 0 \tag{25}$$

where k_1 and k_2 are any two numbers.

Foot and length of the perpendicular from a point $P_1(\alpha, \beta, \gamma)$ to a given line $L: \frac{x-x_1}{l} = \frac{y-y_1}{m} = \frac{z-z_1}{n}$

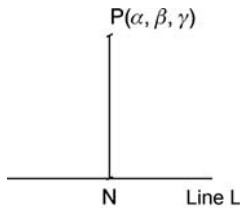

Fig. 3.13

Any point on the line L be $(x_1 + lr, y_1 + mr, z_1 + nr)$. The DR's of PN are $x_1 + lr - \alpha, y_1 + mr - \beta, z_1 + nr - \gamma$. Since PN is \perp^r to line L , then

$$l(x_1 + lr - \alpha) + m(y_1 + mr - \beta) + n(z_1 + nr - \gamma) = 0.$$

Solving

$$r = \frac{l(\alpha - x_1) + m(\beta - y_1) + n(\gamma - z_1)}{l^2 + m^2 + n^2} \tag{26}$$

The coordinates of N , the foot of the perpendicular PN is $(x_1 + lr - \alpha, y_1 + mr - \beta, z_1 + nr - \gamma)$ where r is given by (26).

The length of the perpendicular PN is obtained by distance formula between P (given) and N (found).

Line of greatest slope in a plane

Let ML be the line of intersection of a horizontal plane I with slant plane II. Let P be any point on plane II. Draw $PN \perp^r$ to the line ML . Then the line of greatest slope in plane II is the line PN , because no other line in plane II through P is inclined to the horizontal plane I more steeply than PN .

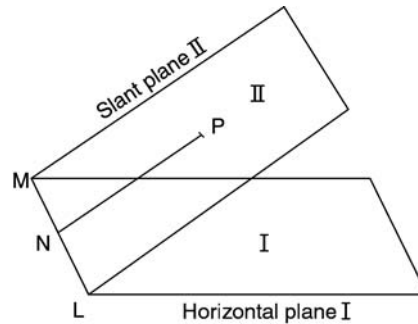

Fig. 3.14

WORKED OUT EXAMPLES

Example 1: Find the points where the line $x - y + 2z = 2, 2x - 3y + 4z = 0$ pierces the coordinate planes.

Solution: Put $z = 0$ to find the point at which the line pierces the xy -plane: $x - y = 2$ and $2x - 3y = 0$ or $x = 6, y = 4. \therefore (6, 4, 0)$.

Put $x = 0, -y + 2z = 2, -3y + 4z = 0$ or $y = 4, z = 3 \therefore (0, 4, 3)$ is piercing point.

Put $y = 0, x + 2z = 2, 2x + 4z = 0$ no unique solution.

Note that DR's of the line are $[2, 0, -1]$. So this line is \perp^r to y -axis whose DR's are $[0, 1, 0]$ (i.e., $2 \cdot 0 + 0 \cdot 1 + (-1) \cdot 0 = 0$). Hence the given line does not pierce the xz -plane.

ANALYTICAL SOLID GEOMETRY — 3.17

Example 2: Transfer the general (unsymmetrical) form $x + 2y + 3z = 1$ and $x + y + 2z = 0$ to the symmetrical form.

Solution: Put $x = 0$, $2y + 3z = 1$, $y + 2z = 0$. Solving $z = -1$, $y = 2$. So $(0, 2, -1)$ is a point on the line. Let l, m, n be the DR's of the line. Since this line is \perp^r to both normals of the given two planes, we have

$$1 \cdot l + 2 \cdot m + 3 \cdot n = 0$$

$$1 \cdot l + 1 \cdot m + 2 \cdot n = 0$$

$$\text{Solving } \frac{l}{4-3} = -\frac{m}{2-3} = \frac{n}{1-2} \text{ or } \frac{l}{1} = \frac{m}{1} = -\frac{n}{1}$$

Equation of the line passing through the point $(0, 2, -1)$ and having DR's $1, 1, -1$ is

$$\frac{x-0}{1} = \frac{y-2}{2} = \frac{z+1}{-1}$$

Aliter: Two point form.

Put $y = 0$, $x + 3z = 1$, $x + 2z = 0$. Solving $z = 1$, $x = -2$ or $(-2, 0, 1)$ is another point on the line. Now DR's of the line joining the two points $(0, 2, -1)$ and $(-2, 0, 1)$ are $-2, -2, 2$. Hence the equation of the line in the two point form is

$$\frac{x-0}{-2} = \frac{y-2}{-2} = \frac{z+1}{2} \text{ or } \frac{x}{1} = \frac{y-2}{1} = \frac{z+1}{-1}$$

Example 3: Find the acute angle between the lines $\frac{x}{2} = \frac{y}{2} = \frac{z}{1}$ and $\frac{x}{5} = \frac{y}{4} = \frac{z}{-3}$.

Solution: DR's are $[2, 2, 1]$ and $[5, 4, -3]$. If θ is the angle between the two lines, then

$$\begin{aligned} \cos \theta &= \frac{l_1 l_2 + m_1 m_2 + n_1 n_2}{\sqrt{l_1^2 + m_1^2 + n_1^2} \sqrt{l_2^2 + m_2^2 + n_2^2}} \\ &= \frac{2 \cdot 5 + 2 \cdot 4 + 1 \cdot (-3)}{\sqrt{4 + 4 + 1} \sqrt{25 + 16 + 9}} = \frac{15}{3\sqrt{50}} = \frac{1}{\sqrt{2}} \end{aligned}$$

$$\therefore \theta = 45^\circ$$

Example 4: Find the equation of the plane containing the line $x = y = z$ and passing through the point $(1, 2, 3)$.

Solution: General form of the given line is

$$x - y = 0 \quad \text{and} \quad x - z = 0.$$

Equation of a plane containing this line is

$$(x - y) + k(x - z) = 0$$

Since point $(1, 2, 3)$ lies on this line, it also lies on the above plane. Then

$$(1 - 2) + k(1 - 3) = 0 \quad \text{or} \quad k = -\frac{1}{2}$$

Equation of required plane is

$$(x - y) - \frac{1}{2}(x - z) = 0$$

or

$$x - 2y + z = 0.$$

Example 5: Show that the lines $\frac{x}{1} = \frac{y+3}{2} = \frac{z+1}{3}$ and $\frac{x-3}{2} = \frac{y}{1} = \frac{z-1}{-1}$ intersect. Find the point of intersection.

Solution: Rewriting the equation in general form, we have

$$2x - y = 3, \quad 3x - z = 1$$

and

$$x - 2y = 3, \quad x + 2z = 5$$

If these four equations have a common solution, then the given two lines intersect. Solving, $y = -1$, then $x = 1$, $z = 2$. So the point of intersection is $(1, -1, 2)$.

Example 6: Find the acute angle between the lines $\frac{x}{3} = \frac{y}{1} = \frac{z}{0}$ and the plane $x + 2y - 7 = 0$.

Solution: DR's of the line: $[3, 1, 0]$. DR's of normal to the plane is $[1, 2, 0]$. If ψ is the angle between the line and the normal, then

$$\begin{aligned} \cos \psi &= \frac{3 \cdot 1 + 1 \cdot 2 + 0 \cdot 0}{\sqrt{3^2 + 1^2 + 0^2} \sqrt{1^2 + 2^2 + 0^2}} \\ &= \frac{5}{\sqrt{10}\sqrt{5}} = \frac{1}{\sqrt{2}} \quad \text{so} \quad \psi = 45^\circ. \end{aligned}$$

Angle θ between the line and the plane is the complement of the angle ψ i.e., $\theta = 90 - \psi = 90 - 45 = 45^\circ$.

Example 7: Show that the lines $x + y - 3z = 0$, $2x + 3y - 8z = 1$ and $3x - y - z = 3$, $x + y - 3z = 5$ are parallel.

Solution: DR's of the first line are

$$\begin{array}{ccc} l_1 & m_1 & n_1 \\ 1 & 1 & -3 \\ 2 & 3 & -8 \end{array} \quad \text{or} \quad \frac{l_1}{1} = \frac{m_1}{2} = \frac{n_1}{1}$$

3.18 — ENGINEERING MATHEMATICS

Similarly, DR's of the second line are

$$\begin{matrix} l_2 & m_2 & n_2 \\ 3 & -1 & -1 \\ 1 & 1 & -3 \end{matrix} \text{ or } \frac{l_2}{4} = \frac{m_2}{8} = \frac{n_2}{4} \text{ i.e., } \frac{l_2}{1} = \frac{m_2}{2} = \frac{n_2}{1}$$

Since the DR's of the two lines are same, they are parallel.

Example 8: Find the acute angle between the lines $2x - y + 3z - 4 = 0$, $3x + 2y - z + 7 = 0$ and $x + y - 2z + 3 = 0$, $4x - y + 3z + 7 = 0$.

Solution: The line represented by the two planes is perpendicular to both the normals of the two planes. If l_1, m_1, n_1 are the DR's of this line, then

$$\begin{matrix} l_1 & m_1 & n_1 \\ 2 & -1 & 3 \\ 3 & 2 & -1 \end{matrix} \text{ or } \frac{l_1}{-5} = \frac{m_1}{11} = \frac{n_1}{7}$$

Similarly, DR's of the 2nd line are

$$\begin{matrix} l_2 & m_2 & n_2 \\ 1 & +1 & -2 \\ 4 & -1 & -3 \end{matrix} \text{ or } \frac{l_2}{-1} = \frac{m_2}{11} = \frac{n_2}{5}$$

If θ is the angle between the lines, then

$$\begin{aligned} \cos \theta &= \frac{l_1 l_2 + m_1 m_2 + n_1 n_2}{\sqrt{l_1^2 + m_1^2 + n_1^2} \sqrt{l_2^2 + m_2^2 + n_2^2}} \\ &= \frac{5 + 121 + 35}{\sqrt{195} \sqrt{147}} = \frac{23}{3\sqrt{65}} \end{aligned}$$

\therefore So $\theta = 180^\circ 1.4'$

Example 9: Prove that the line $\frac{x-4}{2} = \frac{y-2}{3} = \frac{z-3}{6}$ lies in the plane $3x - 4y + z = 7$.

Solution: The point of the line (4, 2, 3) should also lie in the plane. So $3 \cdot 4 - 4 \cdot 2 + 1 \cdot 3 = 7$ satisfied. The line and normal to the plane are perpendicular. So $2 \cdot 3 + 3 \cdot (-4) + 6 \cdot 1 = 6 - 12 + 6 = 0$. Thus the given line completely lies in the given plane.

Example 10: Show that the lines $\frac{x-2}{2} = \frac{y-3}{-1} = \frac{z+4}{3}$ and $\frac{x-3}{1} = \frac{y+1}{3} = \frac{z-1}{-2}$ are coplanar. Find their common point and determine the equation of the plane containing the two given lines.

Solution: Here first line passes through (2, 3, -4) and has DR's $l_1, m_1, n_1 : 2, -1, 3$. The second line

passes through (3, -1, 1) and has DR's $l_2, m_2, n_2 : 1, 3, -2$. Condition for coplanarity:

$$\begin{vmatrix} x_2 - x_1 & y_2 - y_1 & z_2 - z_1 \\ l_1 & m_1 & n_1 \\ l_2 & m_2 & n_2 \end{vmatrix} = \begin{vmatrix} 3-2 & -1-3 & 1+4 \\ 2 & -1 & 3 \\ 1 & 3 & 2 \end{vmatrix} = 7+28-35 = 0 \text{ satisfied.}$$

Point of intersection: Any point on the first line is $(2 + 2r_1, 3 - r_1 - 4 + 3r_1)$ and any point on the second line is $(3 + r_2, -1 + 3r_2, 1 - 2r_2)$. When the two lines intersect in a common point then co-ordinates on line (1) and line (2) must be equal, i.e., $2 + 2r_1 = 3 + r_2, 3 - r_1 = -1 + 3r_2$ and $-4 + 3r_1 = 1 - 2r_2$. Solving $r_1 = r_2 = 1$. Therefore the point of intersection is $(2 + 2 \cdot 1, 3 - 1, -4 + 3 \cdot 1) = (4, 2, -1)$.

Equation of plane containing the two lines:

$$\begin{vmatrix} x-x_1 & y-y_1 & z-z_1 \\ l_1 & m_1 & n_1 \\ l_2 & m_2 & n_2 \end{vmatrix} = \begin{vmatrix} x-2 & y-3 & z+4 \\ 2 & -1 & 3 \\ 1 & 3 & -2 \end{vmatrix} = 0$$

Expanding $-7(x-2) - (-7)(y-3) + 7(z+4) = 0$ or $x - y - z + 3 = 0$.

Example 11: Find the coordinates of the foot of the perpendicular from $P(1, 0, 2)$ to the line $\frac{x+1}{3} = \frac{y-2}{-2} = \frac{z+1}{-1}$. Find the length of the perpendicular and its equation.

Solution: Any point N on the given line is $(3r - 1, 2 - 2r, -1 - r)$. DR's of PN are $(3r - 2, 2 - 2r, -3 - r)$. Now PN is normal to line if $3(3r - 2) + (-2)(2 - 2r) + (-1)(-3 - r) = 0$ or $r = \frac{1}{2}$. So the coordinates of N the foot of the perpendicular from P to the line are $(3 \cdot \frac{1}{2} - 1, 2 - 2 \cdot \frac{1}{2}, -1 - \frac{1}{2})$ or $(\frac{1}{2}, 1, -\frac{3}{2})$.

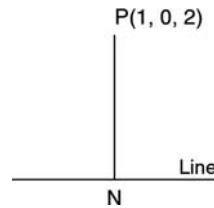

ANALYTICAL SOLID GEOMETRY — 3.19

Length of the perpendicular

$$PN = \sqrt{\left(\frac{1}{2} - 1\right)^2 + (1 - 0)^2 + \left(-\frac{3}{2} - 2\right)^2}$$

$$= \sqrt{\frac{1}{4} + 1 + \frac{49}{4}} = \sqrt{\frac{54}{4}} = \frac{3}{2}\sqrt{6}.$$

DR's of PM with $r = \frac{1}{2}$ are $[3 \cdot \frac{1}{2} - 2, 2 - 2 \cdot \frac{1}{2}, -3 - \frac{1}{2}]$ i.e., DR's of PM are $\frac{1}{2}, -1, \frac{7}{2}$. And PM passes through $P(1, 0, 2)$. Therefore the equation of the perpendicular PM

$$\frac{x-1}{\frac{1}{2}} = \frac{y-0}{-1} = \frac{z-2}{\frac{7}{2}} \quad \text{or} \quad x-1 = \frac{y}{-2} = \frac{z-2}{7}.$$

Example 12: Find the equation of the line of the greatest slope through the point $(2, 1, 1)$ in the slant plane $2x + y - 5z = 0$ to the horizontal plane $4x - 3y + 7z = 0$.

Solution: Let l_1, m_1, n_1 be the DR's of the line of intersection ML of the two given planes. Since ML is \perp to both normals,

$$2l_1 + m_1 - 5n_1 = 0, \quad 4l_1 - 3m_1 + 7n_1 = 0.$$

Solving $\frac{l_1}{4} = \frac{m_1}{17} = \frac{n_1}{5}$. Let PN be the line of greatest slope and let l_2, m_2, n_2 be its DR's. Since PN and ML are perpendicular

$$4l_2 + 17m_2 + 5n_2 = 0$$

Also PN is perpendicular to normal of the slant plane $2x + y - 5z = 0$. So

$$2l_2 + m_2 - 5n_2 = 0$$

Solving $\frac{l_2}{3} = \frac{m_2}{-1} = \frac{n_2}{1}$.

Therefore the equation of the line of greatest slope PN having DR's $3, -1, 1$ and passing through $P(2, 1, 1)$ is

$$\frac{x-2}{3} = \frac{y-1}{-1} = \frac{z-1}{1}.$$

EXERCISE

- Find the points where the line $x + y + 4z = 6, 2x - 3y - 2z = 2$ pierce the coordinate planes.

Ans. $(0, -2, 2), (4, 2, 0), (2, 0, 1)$

- Transform the general form $3x + y - 2z = 7, 6x - 5y - 4z = 7$ to symmetrical form and two point form.

Hint: $(0, 1, -3), (2, 1, 0)$ are two points on the line.

Ans. $\frac{x-2}{2} = \frac{y-1}{0} = \frac{z-0}{3}$

- Show that the lines $x = y = z + 2$ and $\frac{x-1}{1} = \frac{y}{0} = \frac{z}{2}$ intersect and find the point of intersection.

Hint: Solve $x - y = 0, y - z = 2, y = 0, 2x - z = 2$ simultaneously.

Ans. $(0, 0, -2)$

- Find the equation plane containing the line $x = y = z$ and

a. Passing through the line $x + 1 = y + 1 = z$

b. Parallel to the line $\frac{x+1}{3} = \frac{y}{2} = \frac{z}{-1}$.

Ans. (a) $x - y = 0$; (b) $3x - 4y + z = 0$

- Show that the line $\frac{x+1}{1} = \frac{y}{-1} = \frac{z-2}{2}$ is in the plane $2x + 4y + z = 0$.

Hint: $2(1) + 4(-1) + 1(2) = 0, 2(-1) + 4(0) + 2 = 0$

- Find the equation of the plane containing line $\frac{x-1}{3} = \frac{y-1}{4} = \frac{z-2}{2}$ and parallel to the line $x - 2y + 3z = 4, 2x - 3y + 4z = 5$.

Hint: Eq. of 2nd line $\frac{x-0}{\frac{3}{2}} = \frac{y-1}{1} = \frac{z-2}{\frac{2}{2}}$, contains 1st line: $3A + 4B + 2C = 0$. Parallel to 2nd line $A + 2B + C = 0, A = 0, B = -\frac{1}{2}C, D = -\frac{3}{2}C$.

Ans. $y - 2z + 3 = 0$

- Show that the lines $x + 2y - z = 3, 3x - y + 2z = 1$ and $2x - 2y + 3z = 2, x - y + z + 1 = 0$ are coplanar. Find the equation of the plane containing the two lines.

Hint: $\frac{x-0}{3} = \frac{y-3}{-5} = \frac{z-5}{-7}, \frac{x-0}{1} = \frac{y-5}{+1} = \frac{z-4}{0}$.

$$\begin{vmatrix} x-0 & y-5 & z-4 \\ 3 & -5 & -7 \\ 1 & 1 & 0 \end{vmatrix} = 0, \quad \text{Expand.}$$

3.20 — ENGINEERING MATHEMATICS

Ans. $7x - 7y + 8z + 3 = 0$

8. Prove that the equation of the plane through the origin containing the line $\frac{x-1}{5} = \frac{y-2}{4} = \frac{z-3}{5}$ is $x - 5y + 3z = 0$.

Hint: $A(x - 1) + B(y - 2) + C(z - 3) = 0$,
 $5A + 2B + 3C = 0$, $A + 2B + 3C = 0$,

Expand $\begin{vmatrix} x-1 & y-2 & z-3 \\ 5 & 4 & 5 \\ 1 & 2 & 3 \end{vmatrix} = 0$

9. Find the image of the point $P(1, 3, 4)$ in the plane $2x - y + z + 3 = 0$.

Hint: Line through P and \perp^r to plane: $\frac{x-1}{2} = \frac{y-3}{-1} = \frac{z-4}{1}$. Image $Q: (2r + 1, -r + 3, r + 4)$. Mid point L of PQ is $(r + 1, -\frac{1}{2}r + 3, \frac{1}{2}r + 4)$. L lies on plane, $r = -2$.

Ans. $(-3, 5, 2)$

10. Determine the point of intersection of the lines

$$\frac{x-4}{1} = \frac{y+3}{-4} = \frac{z+1}{7}, \frac{x-1}{2} = \frac{y+1}{-3} = \frac{z+10}{8}$$

Hint: General points: $(r_1 + 4, -4r_1 - 3, 7r_1 - 1)$, $(2r_2 + 1, -3r_2 - 1, 8r_2 - 10)$, Equating $r_1 + 4 = 2r_2 + 1$, $-4r_1 - 3 = -3r_2 - 1$, solving $r_1 = 1, r_2 = 2$.

Ans. $(5, -7, 6)$

11. Show that the lines $\frac{x+3}{2} = \frac{y+5}{3} = \frac{z-7}{-3}$, $\frac{x+1}{4} = \frac{y+1}{5} = \frac{z+1}{-1}$ are coplanar. Find the equation of the plane containing them.

Ans. $6x - 5y - z = 0$

12. Find the equation of the line which passes through the point $(2, -1, 1)$ and intersect the lines $2x + y = 4$, $y + 2z = 0$, and $x + 3z = 4$, $2x + 5z = 8$.

Ans. $x + y + z = 2, x + 2z = 4$

13. Find the coordinates of the foot of the perpendicular from $P(5, 9, 3)$ to the line $\frac{x-1}{2} = \frac{y-2}{3} = \frac{z-3}{4}$. Find the length of the perpendicular and its equations.

Ans. $(3, 5, 7)$, Length: 6, Equation $\frac{x-5}{-2} = \frac{y-9}{-4} = \frac{z-3}{4}$.

14. Find the equation of the line of greatest slope in the slant plane $2x + y - 5z = 12$ and passing through the point $(2, 3, -1)$ given that the line $\frac{x}{4} = \frac{y}{-3} = \frac{z}{7}$ is vertical.

Ans.

15. Find the angle between the line $\frac{x+1}{2} = \frac{y}{3} = \frac{z-3}{6}$ and the plane $3x + y + z = 7$.

Hint: DR's of line: 2, 3, 6; DR's of normal to plane 3, 1, 1

$$\cos(90 - \theta) = \sin \theta = \frac{2 \cdot 3 + 3 \cdot 1 + 6 \cdot 1}{\sqrt{4 + 9 + 36} \sqrt{9 + 1 + 1}}$$

Ans. $\sin \theta = \frac{15}{7\sqrt{11}}$

16. Find the angle between the line $x + y - z = 1$, $2x - 3y + z = 2$ and the plane $3x + y - z + 5 = 0$.

Hint: DR's of line 2, 3, 5, DR's of normal: 3, 1, -1

$$\cos(90 - \theta) = \sin \theta = \frac{2 \cdot 3 + 3 \cdot 1 + 5 \cdot (-1)}{\sqrt{4 + 9 + 25} \sqrt{9 + 1 + 1}}$$

Ans. $\sin \theta = \frac{4}{\sqrt{38}\sqrt{11}}$

3.5 SHORTEST DISTANCE BETWEEN SKEW LINES

Skew lines: Any two straight lines which do not lie in the same plane are known as skew lines (or non-planar lines). Such lines neither intersect nor are parallel. **Shortest distance between two skew lines:**

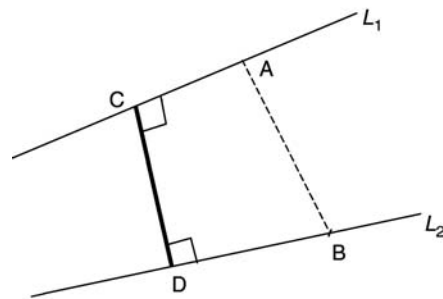

Fig. 3.15

Let L_1 and L_2 be two skew lines; L_1 passing through a given point A and L_2 through a given point

ANALYTICAL SOLID GEOMETRY — 3.21

B. Shortest distance between the two skew lines L_1 and L_2 is the length of the line segment CD which is perpendicular to **both** L_1 and L_2 . The equation of the shortest distance line CD can be uniquely determined since it intersects both lines L_1 and L_2 at right angles. Now $CD =$ projection of AB on $CD = AB \cos\theta$ where θ is the angle between AB and CD . Since $\cos\theta < 1$, $CD < AB$, thus CD is the shortest distance between the lines L_1 and L_2 .

Magnitude (length) and the equations of the line of shortest distance between two lines L_1 and L_2 :

Suppose the equation of given line L_1 be

$$\frac{x - x_1}{l_1} = \frac{y - y_1}{m_1} = \frac{z - z_1}{n_1} \quad (1)$$

and of line L_2 be

$$\frac{x - x_2}{l_2} = \frac{y - y_2}{m_2} = \frac{z - z_2}{n_2} \quad (2)$$

Assume the equation of shortest distance line CD as

$$\frac{x - \alpha}{l} = \frac{y - \beta}{m} = \frac{z - \gamma}{n} \quad (3)$$

where (α, β, γ) and (l, m, n) are to be determined. Since CD is perpendicular to both L_1 and L_2 ,

$$ll_1 + mm_1 + nn_1 = 0$$

$$ll_2 + mm_2 + nn_2 = 0$$

Solving

$$\begin{aligned} \frac{l}{m_1n_2 - m_2n_1} &= \frac{m}{n_1l_2 - n_2l_1} = \frac{n}{l_1m_2 - l_2m_1} \\ &= \frac{\sqrt{l^2 + m^2 + n^2}}{\sqrt{(m_1n_2 - m_2n_1)^2 + (n_1l_2 - n_2l_1)^2 + (l_1m_2 - l_2m_1)^2}} \\ &= \frac{1}{\sqrt{\sum(m_1n_2 - m_2n_1)^2}} = \frac{1}{k} \end{aligned}$$

where $k = \sqrt{\sum(m_1n_2 - m_2n_1)^2}$

or $l = \frac{m_1n_2 - m_2n_1}{k}, \quad m = \frac{n_1l_2 - n_2l_1}{k},$
 $n = \frac{l_1m_2 - l_2m_1}{k} \quad (4)$

Thus the DC's l, m, n of the shortest distance line CD are determined by (4).

Magnitude of shortest distance $CD =$ projection of AB on CD where $A(x_1, y_1, z_1)$ is a point on L_1 and $B(x_2, y_2, z_2)$ is a point on L_2 .

\therefore shortest distance $CD =$
 $= l(x_2 - x_1) + m(y_2 - y_1) + n(z_2 - z_1) \quad (5)$

In the determinant form,

$$\text{Shortest distance } CD = \frac{1}{k} \begin{vmatrix} x_2 - x_1 & y_2 - y_1 & z_2 - z_1 \\ l_1 & m_1 & n_1 \\ l_2 & m_2 & n_2 \end{vmatrix} \quad (5')$$

Note: If shortest distance is zero, then the two lines L_1 and L_2 are coplanar.

Equation of the line of shortest distance CD : Observe that CD is coplanar with both L_1 and L_2 . Let P_1 be the plane containing L_1 and CD . Equation of plane P_1 containing coplanar lines L_1 and CD is

$$\begin{vmatrix} x - x_1 & y - y_1 & z - z_1 \\ l_1 & m_1 & n_1 \\ l & m & n \end{vmatrix} = 0 \quad (6)$$

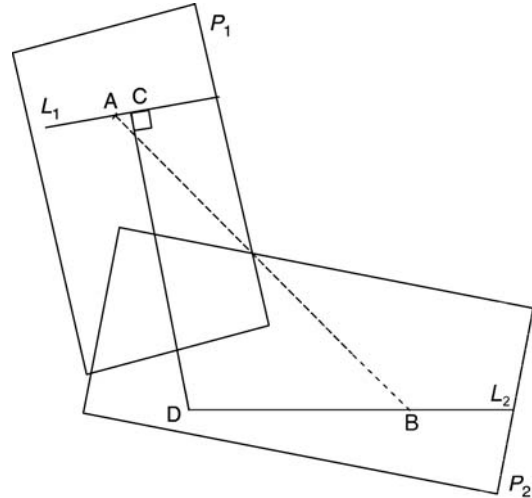

Fig. 3.16

Similarly, equation of plane P_2 containing L_2 and CD is

$$\begin{vmatrix} x - x_2 & y - y_2 & z - z_2 \\ l_2 & m_2 & n_2 \\ l & m & n \end{vmatrix} = 0 \quad (7)$$

3.22 — ENGINEERING MATHEMATICS

Equations (6) and (7) together give the equation of the line of shortest distance.

Points of intersection C and D with L_1 and L_2 :

Any general point C^* on L_1 is

$$(x_1 + l_1r_1, \quad y_1 + m_1r_1, \quad z_1 + n_1r_1)$$

and any general point D^* on L_2 is

$$(x_2 + l_2r_2, \quad y_2 + m_2r_2, \quad z_2 + n_2r_2)$$

$$\text{DR's of } C^*D^*: (x_2 - x_1 + l_2r_2 - l_1r_1, \quad y_2 - y_1 + m_2r_2 - m_1r_1, \quad z_2 - z_1 + n_2r_2 - n_1r_1)$$

If C^*D^* is \perp^r to both L_1 and L_2 , we get two equations for the two unknowns r_1 and r_2 . Solving and knowing r_1 and r_2 , the coordinates of C and D are determined. Then the magnitude of CD is obtained by length formula, and equation of CD by two point formula.

Parallel planes: Shortest distance CD = perpendicular distance from any point on L_1 to the plane parallel to L_1 and containing L_2 .

WORKED OUT EXAMPLES

Example 1: Find the magnitude and equation of the line of shortest distance between the lines

$$\frac{x-1}{2} = \frac{y-2}{3} = \frac{z-3}{4},$$

$$\frac{x-2}{3} = \frac{y-4}{4} = \frac{z-5}{5}.$$

Solution: Point $A(x_1, y_1, z_1)$ on first line is (1, 2, 3) and $B(x_2, y_2, z_2)$ on second line is (2, 4, 5). Also (l_1, m_1, n_1) are (2, 3, 4) and $(l_2, m_2, n_2) = (3, 4, 5)$. Then

$$k^2 = (m_1n_2 - m_2n_1)^2 + (n_1l_2 - n_2l_1)^2 + (l_1m_2 - l_2m_1)^2$$

$$= (15 - 16)^2 + (12 - 10)^2 + (8 - 9)^2$$

$$= 1 + 4 + 1 = 6 \quad \text{or} \quad k = \sqrt{6}.$$

So DR's is of line of shortest of distance: $-\frac{1}{\sqrt{6}}, \frac{2}{\sqrt{6}}, -\frac{1}{\sqrt{6}}$.

$$\text{Shortest distance} = \frac{1}{k} \begin{vmatrix} x_2 - x_1 & y_2 - y_1 & z_2 - z_1 \\ l_1 & m_1 & n_1 \\ l_2 & m_2 & n_2 \end{vmatrix}$$

$$= \begin{vmatrix} 1 & 2 & 2 \\ 2 & 3 & 4 \\ 3 & 4 & 5 \end{vmatrix} \frac{1}{\sqrt{6}}$$

$$= \frac{(15 - 16) - 2(10 - 12) + 2(8 - 9)}{\sqrt{6}}$$

$$= \frac{-1 + 4 - 2}{\sqrt{6}} = \frac{1}{\sqrt{6}}.$$

Equation of shortest distance line:

$$\begin{vmatrix} x-1 & y-2 & z-3 \\ 2 & 3 & 4 \\ -\frac{1}{\sqrt{6}} & \frac{2}{\sqrt{6}} & -\frac{1}{\sqrt{6}} \end{vmatrix} = 0 \quad \text{or} \quad 11x + 2y - 7z + 6 = 0$$

and

$$\begin{vmatrix} x-1 & y-4 & z-5 \\ 2 & 3 & 4 \\ -\frac{1}{\sqrt{6}} & \frac{2}{\sqrt{6}} & -\frac{1}{\sqrt{6}} \end{vmatrix} = 0 \quad \text{or} \quad 7x + y - 5z + 7 = 0.$$

Example 2: Determine the points of intersection of the line of shortest distance with the two lines

$$\frac{x-3}{3} = \frac{y-8}{-1} = \frac{z-3}{1}; \quad \frac{x+3}{-3} = \frac{y+7}{2} = \frac{z-6}{4}.$$

Also find the magnitude and equation of shortest distance.

Solution: Any general point C^* on first line is $(3 + 3r_1, 8 - r_1, 3 + r_1)$ and any general point D^* on the second line is $(-3 - 3r_2, -7 + 2r_2, 6 - 4r_2)$. DR's of C^*D^* are $(6 + 3r_1 + 3r_2, 15 - r_1 - 2r_2, -3 + r_1 - 4r_2)$. If C^*D^* is \perp^r to both the given lines, then

$$3(6+3r_1+3r_2)-1(15-r_1-2r_2)+1(-3+r_1-4r_2)=0$$

$$-3(6+3r_1+3r_2)+2(15-r_1-2r_2)+4(-3+r_1-4r_2)=0$$

Solving for r_1 and r_2 , $11r_1 - 7r_2 = 0$, $+7r_1 + 29r_2 = 0$ so $r_1 = r_2 = 0$. Then the points of intersection of shortest distance line CD with the given two lines are $C(3, 8, 3)$, $D(-3, -7, 6)$.

$$\text{Length of } CD = \sqrt{(-6)^2 + (-15)^2 + (3)^2}$$

$$= \sqrt{270} = 3\sqrt{30}$$

$$\text{Equation } CD: \frac{x-3}{-3-3} = \frac{y-8}{-7-8} = \frac{z-3}{6-3}$$

$$\text{i.e.,} \quad \frac{x-3}{-6} = \frac{y-8}{-15} = \frac{z-3}{3}.$$

Example 3: Calculate the length and equation of

ANALYTICAL SOLID GEOMETRY — 3.23

line of shortest distance between the lines

$$\begin{aligned} 5x - y - z = 0, \quad x - 2y + z + 3 = 0 & \quad (1) \\ 7x - 4y - 2z = 0, \quad x - y + z - 3 = 0 & \quad (2) \end{aligned}$$

Solution: Any plane containing the second line (2) is

$$\begin{aligned} (7x - 4y - 2z) + \mu(x - y + z - 3) = 0 \\ \text{or } (7 + \mu)x + (-4 - \mu)y + (-2 + \mu)z - 3\mu = 0 \quad (3) \end{aligned}$$

DR's of first line (1) are $(l, m, n) = (-3, -6, -9)$ obtained from:

$$\begin{array}{ccc} l & m & n \\ 5 & -1 & -1 \\ l & -2 & 1 \end{array}$$

The plane (3) will be parallel to the line (1) with $l = -3, m = -6, n = -9$ if

$$-3(7 + \mu) + 6(4 + \mu) + 9(2 - \mu) = 0 \quad \text{or} \quad \mu = \frac{7}{2}$$

Substituting μ in (3), we get the equation of a plane containing line (2) and parallel to line (1) as

$$7x - 5y + z - 7 = 0 \quad (4)$$

To find an arbitrary point on line (1), put $x = 0$. Then $-y - z = 0$ or $y = -z$ and $-2y + z + 3 = 0, z = -1, y = 1$. $\therefore (0, 1, -1)$ is a point on line (1). Now the length of the shortest distance = perpendicular distance of $(0, 1, -1)$ to plane (4)

$$= \frac{0 - 5(1) + (-1) - 7}{\sqrt{49 + 25 + 1}} = \left| \frac{-13}{\sqrt{75}} \right| = \frac{13}{\sqrt{75}} \quad (5)$$

Equation of any plane through line (1) is

$$\begin{aligned} 5x - y - z + \lambda(x - 2y + z + 3) = 0 \\ \text{or } (5 + \lambda)x + (-y - 2\lambda)y + (-1 + \lambda)z + 3\lambda = 0 \quad (6) \end{aligned}$$

DR's of line (2) are $(l, m, n) = (2, 3, 1)$ obtained from

$$\begin{array}{ccc} l & m & n \\ 7 & -4 & -2 \\ 1 & -1 & 1 \end{array}$$

plane (6) will be parallel to line (2) if

$$2(5 + \lambda) + 3(-y - 2\lambda) + 1(-1 + \lambda) = 0 \quad \text{or} \quad \lambda = 2.$$

Thus the equation of plane containing line (1) and parallel to line (2) is

$$7x - 5y + z + 6 = 0 \quad (7)$$

Hence equation of the line of shortest distance is given by (6) and (7) together.

3.24 — ENGINEERING MATHEMATICS

Aliter: A point on line (2) is (0, -1, 2) obtained by putting $x = 0$ and solving (2). Then the length of shortest distance = perpendicular distance of (0, -1, 2) to the plane (7) = $\frac{0+5+2+6}{\sqrt{75}} = \frac{13}{\sqrt{75}}$

Note: By reducing (1) and (2) to symmetric forms

$$\frac{x - \frac{1}{3}}{1} = \frac{y - \frac{5}{3}}{2} = \frac{z}{3}$$

$$\frac{x + 4}{1} = \frac{y + 7}{\frac{3}{2}} = \frac{z}{\frac{1}{2}}$$

The problem can be solved as in above worked Example 1.

Example 4: Show that the lines $\frac{x-1}{2} = \frac{y-2}{3} = \frac{z-3}{4}$; $\frac{x-2}{3} = \frac{y-3}{4} = \frac{z-4}{5}$ are coplanar.

Solution: Shortest distance between the two lines is

$$\begin{vmatrix} 2 & -1 & 3 & -2 & 4 & -3 \\ 2 & 3 & 4 & 3 & 4 & 5 \end{vmatrix} = \begin{vmatrix} 1 & 1 & 1 \\ 2 & 3 & 4 \\ 3 & 4 & 5 \end{vmatrix} = (-1) - (-2) + (-1) = 0$$

∴ Lines are coplanar.

Example 5: If a, b, c are the lengths of the edges of a rectangular parallelepiped, show that the shortest distance between a diagonal and an edge not meeting the diagonal is $\frac{bc}{\sqrt{b^2+c^2}}$ (or $\frac{ca}{\sqrt{c^2+a^2}}$ or $\frac{ab}{\sqrt{a^2+b^2}}$).

Solution: Choose coterminal edges OA, OB, OC along the X, Y, Z axes. Then the coordinates are $A(a, 0, 0), B(0, b, 0), C(0, 0, c), E(a, b, 0), D(0, b, c), G(a, 0, c)F(a, b, c)$ etc. so that $OA = a, OB = b, OC = c$.

To find the shortest distance between a diagonal OF and an edge GC . Here GC does not intersect OF

Equation of the line $OF: \frac{x-0}{a-0} = \frac{y-0}{b-0} = \frac{z-0}{c-0}$

or $\frac{x}{a} = \frac{y}{b} = \frac{z}{c}$ (1)

Equation of the line $GC: \frac{x-0}{a-0} = \frac{y-0}{b-0} = \frac{z-c}{c-c}$

or $\frac{x}{1} = \frac{y}{0} = \frac{z-c}{0}$ (2)

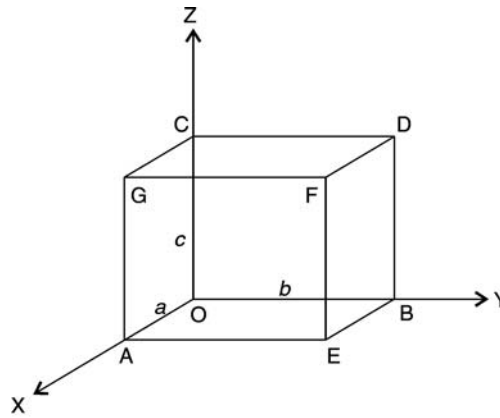

Fig. 3.17

Equation of a plane containing line (1) and parallel to (2) is

$$\begin{vmatrix} x & y & z \\ a & b & c \\ 1 & 0 & 0 \end{vmatrix} = 0 \quad \text{or} \quad cy - bz = 0 \quad (3)$$

Shortest distance = Length of perpendicular drawn from a point say $C(0, 0, c)$ to the plane (3)

$$= \frac{c \cdot 0 - b \cdot c}{\sqrt{0^2 + c^2 + b^2}} = \frac{bc}{\sqrt{c^2 + b^2}}$$

In a similar manner, it can be proved that the shortest distance between the diagonal OF and non-intersecting edges AN and AM are respectively $\frac{ca}{\sqrt{c^2+a^2}}, \frac{ab}{\sqrt{a^2+b^2}}$.

EXERCISE

- Determine the magnitude and equation of the line of shortest distance between the lines. Find the points of intersection of the shortest distance line, with the given lines

$$\frac{x-8}{3} = \frac{y+9}{-16} = \frac{z-10}{7}, \quad \frac{x-15}{3} = \frac{y-29}{8} = \frac{z-5}{-5}$$

Ans. $14, 117x + 4y - 41z - 490 = 0, 9x - 4y - z = 14$, points of intersection (5, 7, 3), (9, 13, 15).

- Calculate the length, points of intersection, the equations of the line of shortest distance between the two lines

$$\frac{x+1}{2} = \frac{y+1}{3} = \frac{z+1}{4}, \quad \frac{x+1}{3} = \frac{y}{4} = \frac{z}{5}$$

ANALYTICAL SOLID GEOMETRY — 3.25

Ans. $\frac{1}{\sqrt{6}}, \frac{x-\frac{5}{3}}{\frac{1}{6}} = \frac{y-3}{-\frac{1}{2}} = \frac{z-\frac{15}{2}}{\frac{1}{6}}, (\frac{5}{3}, 3, \frac{13}{3}),$
 $(\frac{3}{2}, \frac{10}{3}, \frac{25}{6}).$

3. Find the magnitude and equations of shortest distance between the two lines

$$\frac{x-1}{2} = \frac{y-2}{3} = \frac{z-3}{4}, \quad \frac{x-2}{3} = \frac{y-4}{4} = \frac{z-5}{5}.$$

Ans. $\frac{1}{\sqrt{6}}, 11x + 2y - 7z + 6 = 0, 7x + y - 5z + 7 = 0.$

4. Show that the shortest distance between the lines $\frac{x}{2} = \frac{y}{-3} = \frac{z}{1}$ and $\frac{x-2}{3} = \frac{y-1}{-5} = \frac{z+2}{2}$ is $\frac{1}{\sqrt{3}}$ and its equations are $4x + y - 5z = 0, 7x + y - 8z = 31.$

5. Determine the points on the lines $\frac{x-6}{3} = \frac{y-7}{-1} = \frac{z-4}{-3}, \frac{x}{-3} = \frac{y+9}{2} = \frac{z-2}{4}$ which are nearest to each other. Hence find the shortest distance between the lines and find its equations.

Ans. $(3, 8, 3), (-3, -7, 6), 3\sqrt{30}, \frac{x-3}{2} = \frac{y-8}{5} = \frac{z-3}{-1}.$

6. Prove that the shortest distance between the two lines $\frac{x-1}{3} = \frac{y-4}{2} = \frac{z-4}{-2}, \frac{x+1}{2} = \frac{y-1}{-4} = \frac{z+2}{1}$ is $\frac{120}{\sqrt{341}}$

Hint: Equation of a plane passing through the first lines and parallel to the second line is $6x + 7y + 16z = 98.$ A point on second line is $(-1, 1, -2).$ Perpendicular distance = $\frac{6(-1)+7(1)+16(-2)}{\sqrt{6^2+7^2+16^2}}.$

7. Find the length and equations of shortest distance between the lines $x - y + z = 0, 2x - 3y + 4z = 0;$ and $x + y + 2z - 3 = 0, 2x + 3y + 3z - 4 = 0.$

Hint: Equations of two lines in symmetric form are $\frac{x}{1} = \frac{y}{2} = \frac{z}{1}, \frac{x-5}{-3} = \frac{y+2}{1} = \frac{z}{1}.$

Ans. $\frac{13}{\sqrt{66}}, 3x - y - z = 0, x + 2y + z - 1 = 0.$

8. Determine the magnitude and equations of the line of shortest distance between the lines $\frac{x-3}{2} = \frac{y+15}{-7} = \frac{z-9}{5}$ and $\frac{x+1}{2} = \frac{y-1}{1} = \frac{z-9}{-3}.$

Ans. $4\sqrt{3}, -4x + y + 3z = 0, 4x - 5y + z = 0$ (or $x = y = z).$

9. Obtain the coordinates of the points where the line of shortest distance between the lines $\frac{x-23}{-6} = \frac{y-19}{-4} = \frac{z-25}{3}$ and $\frac{x-12}{-9} = \frac{y-1}{4} = \frac{z-5}{2}$ meets them. Hence find the shortest distance between the two lines.

Ans. $(11, 11, 31), (3, 5, 7), 26$

10. Find the shortest distance between any two opposite edges of a tetrahedron formed by the planes $x + y = 0, y + z = 0, z + x = 0, x + y + z = a.$ Also find the point of intersection of three lines of shortest distances.

Hint: Vertices are $(0, 0, 0), (a, -a, a), (-a, a, a), (a, a, -a).$

Ans. $\frac{2a}{\sqrt{6}}, (-a, -a, -a).$

11. Find the shortest distance between the lines PQ and RS where $P(2, 1, 3), Q(1, 2, 1), R(-1, -2, -2), S(-1, 4, 0).$

Ans. $3\sqrt{2}$

3.6 THE RIGHT CIRCULAR CONE

Cone

A **cone** is a surface generated by a straight line (known as **generating line or generator**) passing through a fixed point (known as **vertex**) and satisfying a condition, for example, it may intersect a given curve (known as **guiding curve**) or touches a given surface (say a sphere). Thus cone is a set of points on its generators. Only cones with second degree equations known as quadratic cones are considered here. In particular, quadratic cones with vertex at origin are homogeneous equations of second degree.

Equation of cone with vertex at (α, β, γ) and the conic $ax^2 + 2hxy + by^2 + 2gx + 2fy + c = 0, z = 0$ as the guiding curve:

The equation of any line through vertex (α, β, γ) is

$$\frac{x-\alpha}{l} = \frac{y-\beta}{m} = \frac{z-\gamma}{n} \quad (1)$$

(1) will be generator of the cone if (1) intersects the given conic

$$ax^2 + 2hxy + by^2 + 2gx + 2fy + c = 0, z = 0 \quad (2)$$

Since (1) meets $z = 0,$ put $z = 0$ in (1), then the point

3.26 — ENGINEERING MATHEMATICS

$(\alpha - \frac{l\gamma}{n}, \beta - \frac{m\gamma}{n}, 0)$ will lie on the conic (2), if

$$a\left(\alpha - \frac{l\gamma}{n}\right)^2 + 2h\left(\alpha - \frac{l\gamma}{n}\right)\left(\beta - \frac{m\gamma}{n}\right) + b\left(\beta - \frac{m\gamma}{n}\right)^2 + 2g\left(\alpha - \frac{l\gamma}{n}\right) + 2f\left(\beta - \frac{m\gamma}{n}\right) + c = 0 \quad (3)$$

From (1)

$$\frac{l}{n} = \frac{x - \alpha}{z - \gamma}, \quad \frac{m}{n} = \frac{y - \beta}{z - \gamma} \quad (4)$$

Eliminate l, m, n from (3) using (4),

$$a\left(\alpha - \frac{x - \alpha}{z - \gamma} \cdot \gamma\right)^2 + 2h\left(\alpha - \frac{x - \alpha}{z - \gamma} \cdot \gamma\right)\left(\beta - \frac{y - \beta}{z - \gamma} \cdot \gamma\right) + b\left(\beta - \frac{y - \beta}{z - \gamma} \cdot \gamma\right)^2 + 2g\left(\alpha - \frac{x - \alpha}{z - \gamma} \cdot \gamma\right) + 2f\left(\beta - \frac{y - \beta}{z - \gamma} \cdot \gamma\right) + c = 0$$

or

$$a(\alpha z - x\gamma)^2 + 2h(\alpha z - x\gamma)(\beta z - y\gamma) + b(\beta z - y\gamma)^2 + 2g(\alpha z - x\gamma)(z - \gamma) + 2f(\beta z - y\gamma)(z - \gamma) + c(z - \gamma)^2 = 0$$

or

$$a(x - \alpha)^2 + b(y - \beta)^2 + c(z - \gamma)^2 + 2f(z - \gamma)(y - \beta) + 2g(x - \alpha)(z - \gamma) + 2h(x - \alpha)(y - \beta) = 0 \quad (5)$$

Thus (5) is the equation of the quadratic cone with vertex at (α, β, γ) and guiding curve as the conic (2).

Special case: Vertex at origin $(0, 0, 0)$. Put $\alpha = \beta = \gamma = 0$ in (5). Then (5) reduces to

$$ax^2 + by^2 + cz^2 + 2fzy + 2gxz + 2hxy = 0 \quad (6)$$

Equation (6) which is a homogeneous and second degree in x, y, z is the equation of cone with vertex at origin.

Right circular cone

A right circular cone is a surface generated by a line (**generator**) through a fixed point (**vertex**) making a

constant angle θ (**semi-vertical angle**) with the fixed line (**axis**) through the fixed point (**vertex**). Here the guiding curve is a circle with centre at c . Thus every section of a right circular cone by a plane perpendicular to its axis is a circle.

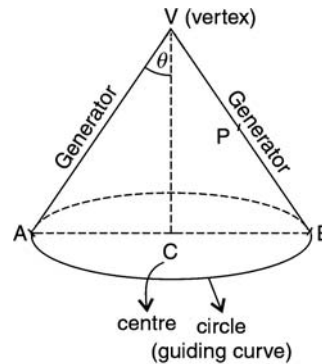

Fig. 3.18

Equation of a right circular cone: with vertex at (α, β, γ) , semi vertical angle θ and equation of axis

$$\frac{x - \alpha}{l} = \frac{y - \beta}{m} = \frac{z - \gamma}{n} \quad (1)$$

Let $P(x, y, z)$ be any point on the generating line VB . Then the DC's of VB are proportional to $(x - \alpha, y - \beta, z - \gamma)$. Then

$$\cos \theta = \frac{l(x - \alpha) + m(y - \beta) + n(z - \gamma)}{\sqrt{(l^2 + m^2 + n^2)}\sqrt{(x - \alpha)^2 + (y - \beta)^2 + (z - \gamma)^2}}$$

Rewriting, the required equation of cone is

$$\left[l(x - \alpha) + m(y - \beta) + n(z - \gamma)\right]^2 = (l^2 + m^2 + n^2)\left[(x - \alpha)^2 + (y - \beta)^2 + (z - \gamma)^2\right] \cos^2 \theta \quad (2)$$

Case 1: If vertex is origin $(0, 0, 0)$ then (2) reduces

$$(lx + my + nz)^2 = (l^2 + m^2 + n^2)(x^2 + y^2 + z^2) \cos^2 \theta \quad (3)$$

Case 2: If vertex is origin and axis of cone is z-axis (with $l = 0, m = 0, n = 1$) then (2) becomes

$$z^2 = (x^2 + y^2 + z^2) \cos^2 \theta \quad \text{or} \quad z^2 \sec^2 \theta = x^2 + y^2 + z^2$$

$$z^2(1 + \tan^2 \theta) = x^2 + y^2 + z^2$$

i.e., $x^2 + y^2 = z^2 \tan^2 \theta \quad (4)$

Similarly, with y-axis as the axis of cone

ANALYTICAL SOLID GEOMETRY — 3.27

$$x^2 + z^2 = y^2 \tan^2 \theta$$

with x-axis as the axis of cone

$$y^2 + z^2 = x^2 \tan^2 \theta.$$

If the right circular cone admits sets of three mutually perpendicular generators then the semi-vertical angle $\theta = \tan^{-1} \sqrt{2}$ (since the sum of the coefficients of x^2, y^2, z^2 in the equation of such a cone must be zero i.e., $1 + 1 - \tan^2 \theta = 0$ or $\tan \theta = \sqrt{2}$).

WORKED OUT EXAMPLES

Example 1: Find the equation of cone with base curve $\frac{x^2}{a^2} + \frac{y^2}{b^2} = 1, z = 0$ and vertex (α, β, γ) . Deduce the case when base curve is $\frac{x^2}{16} + \frac{y^2}{9} = 1, z = 0$ and vertex at $(1, 1, 1)$.

Solution: The equation of any generating line through the vertex (α, β, γ) is

$$\frac{x - \alpha}{l} = \frac{y - \beta}{m} = \frac{z - \gamma}{n} \tag{1}$$

This generator (1) meets $z = 0$ in the point

$$\left(x = \alpha - \frac{l\gamma}{n}, \quad y = \beta - \frac{m\gamma}{n}, \quad z = 0 \right) \tag{2}$$

Point (2) lies on the generating curve

$$\frac{x^2}{a^2} + \frac{y^2}{b^2} = 1 \tag{3}$$

Substituting (2) in (3)

$$\frac{\left(\alpha - \frac{l\gamma}{n} \right)^2}{a^2} + \frac{\left(\beta - \frac{m\gamma}{n} \right)^2}{b^2} = 1 \tag{4}$$

Eliminating l, m, n from (4) using (1),

$$\frac{\left[\alpha - \left(\frac{x-\alpha}{z-\gamma} \right) \gamma \right]^2}{a^2} + \frac{\left[\beta - \left(\frac{y-\beta}{z-\gamma} \right) \gamma \right]^2}{b^2} = 1$$

$$b^2 \left[\alpha(z - \gamma) - \gamma(x - \alpha) \right]^2 + a^2 \left[\beta(z - \gamma) - \gamma(y - \beta) \right]^2 = a^2 b^2 (z - \gamma)^2$$

Deduction: When $a = 4, b = 3, \alpha = 1, \beta = 1, \gamma = 1,$

$$9 \left[(z - 1) - (x - 1) \right]^2 + 16 \left[(z - 1) - (y - 1) \right]^2 = 144(z - 1)^2$$

$$9x^2 + 16y^2 - 119z^2 - 18xz - 32yz + 288z - 144 = 0.$$

Example 2: Find the equation of the cone with vertex at $(1, 0, 2)$ and passing through the circle $x^2 + y^2 + z^2 = 4, x + y - z = 1$.

Solution: Equation of generator is

$$\frac{x - 1}{l} = \frac{y - 0}{m} = \frac{z - 2}{n} \tag{1}$$

Any general point on the line (1) is

$$(1 + lr, \quad mr, \quad 2 + nr). \tag{2}$$

Since generator (1) meets the plane

$$x + y - z = 1 \tag{3}$$

substitute (2) in (3)

$$(1 + lr) + (mr) - (2 + nr) = 1$$

or $r = \frac{2}{l + m - n}.$ (4)

Since generator (1) meets the sphere

$$x^2 + y^2 + z^2 = 4 \tag{5}$$

substitute (2) in (5)

$$(1 + lr)^2 + (mr)^2 + (2 + nr)^2 = 4$$

or $r^2(l^2 + m^2 + n^2) + 2r(l + 2n) + 1 = 0$ (6)

Eliminate r from (6) using (4), then

$$\frac{4}{(l+m-n)^2} (l^2 + m^2 + n^2) + 2 \frac{2}{(l+m-n)} (l + 2n) + 1 = 0$$

$$9l^2 + 5m^2 - 3n^2 + 6lm + 2ln + 6nm = 0 \tag{7}$$

Eliminate l, m, n from (7) using (1), then

$$9 \left(\frac{x-1}{r} \right)^2 + 5 \left(\frac{y}{r} \right)^2 - 3 \left(\frac{z-2}{r} \right)^2 + 6 \left(\frac{x-1}{r} \right) \left(\frac{y}{r} \right) + 2 \left(\frac{x-1}{r} \right) \left(\frac{z-2}{r} \right) + 6 \left(\frac{z-2}{r} \right) \left(\frac{y}{r} \right) = 0$$

or $9(x - 1)^2 + 5y^2 - 3(z - 2)^2 + 6y(x - 1) + 2(x - 1)(x - 2) + 6(z - 2)y = 0$

3.28 — ENGINEERING MATHEMATICS

Vertex (0, 0, 0):

Example 3: Determine the equation of a cone with vertex at origin and base curve given by

- a. $ax^2 + by^2 = 2z, \quad lx + my + nz = p$
- b. $ax^2 + by^2 + cz^2 = 1, \quad lx + my + nz = p$
- c. $x^2 + y^2 + z^2 = 25, \quad x + 2y + 2z = 9$

Solution: We know that the equation of a quadratic cone with vertex at origin is a homogeneous equation of second degree in x, y, z . By eliminating the non-homogeneous terms in the base curve, we get the required equation of the cone.

- a. $2z$ is the term of degree one and is non homogeneous. Solving

$$\frac{lx + my + nz}{p} = 1$$

rewrite the equation

$$ax^2 + by^2 = 2 \cdot z(1) = 2z \left(\frac{lx + my + nz}{p} \right)$$

$$apx^2 + bpy^2 - 2nz^2 - 2lzx - 2mzy = 0$$

which is the equation of cone.

- b. Except the R.H.S. term 1, all other terms are of degree 2 (and homogeneous). Rewriting, the required equation of cone as

$$ax^2 + by^2 + cz^2 = (1)^2 = \left(\frac{lx + my + nz}{p} \right)^2$$

$$(ap^2 - l^2)x^2 + (bp^2 - m^2)y^2 + (cp^2 - n^2)z^2 - 2lmxy - 2mnyz - 2lnxz = 0$$

- c. On similar lines

$$x^2 + y^2 + z^2 = 25 = 25(1)^2 = 25 \left(\frac{x + 2y + 2z}{9} \right)^2$$

$$56x^2 - 19y^2 - 19z^2 - 100xy - 200yz - 100xz = 0$$

Right circular cone:

Example 4: Find the equation of a right circular cone with vertex at $(2, 0, 0)$, semi-vertical angle $\theta = 30^\circ$ and axis is the line $\frac{x-2}{3} = \frac{y}{4} = \frac{z}{6}$.

Solution: Here $\alpha = 2, \beta = 0, \gamma = 0, l = 3, m = 4, n = 6$

$$\frac{\sqrt{3}}{2} = \cos 30 = \cos \theta$$

$$= \frac{l(x - \alpha) + m(y - \beta) + n(z - \gamma)}{\sqrt{(l^2 + m^2 + n^2)[(x - \alpha)^2 + (y - \beta)^2 + (z - \gamma)^2]}$$

$$\frac{\sqrt{3}}{2} = \frac{3(x - 2) + 4y + 6z}{\sqrt{9 + 16 + 36}\sqrt{(x - 2)^2 + y^2 + z^2}}$$

$$183[(x - 2)^2 + y^2 + z^2] = 4[3(x - 2) + 4y + 6z]^2$$

$$147x^2 + 119y^2 + 39z^2 - 192yz - 144zx - 96xy - 588x + 192y + 288z + 588 = 0$$

Vertex (0, 0, 0):

Example 5: Find the equation of the right circular cone which passes through the line $2x = 3y = -5z$ and has $x = y = z$ as its axis.

Solution: DC's of the generator $2x = 3y = -5z$ are $\frac{1}{2}, \frac{1}{3}, -\frac{1}{5}$. DC's of axis are $\frac{1}{\sqrt{3}}, \frac{1}{\sqrt{3}}, \frac{1}{\sqrt{3}}$. Point of intersection of the generator and axis is $(0, 0, 0)$. Now

$$\cos \theta = \frac{\frac{1}{2} \cdot \frac{1}{\sqrt{3}} + \frac{1}{3} \cdot \frac{1}{\sqrt{3}} - \frac{1}{5} \cdot \frac{1}{\sqrt{3}}}{\sqrt{\frac{1}{3} + \frac{1}{3} + \frac{1}{3}} \sqrt{\frac{1}{4} + \frac{1}{9} + \frac{1}{25}}} = \frac{\frac{19}{30}}{\sqrt{\frac{361}{900}}} \cdot \frac{1}{\sqrt{3}} = \frac{1}{\sqrt{3}}$$

Equation of cone with vertex at origin

$$\frac{1}{\sqrt{3}} = \cos \theta = \frac{\frac{1}{\sqrt{3}}(x + y + z)}{1\sqrt{x^2 + y^2 + z^2}}$$

$$x^2 + y^2 + z^2 = (x + y + z)^2$$

$$xy + yz + zx = 0.$$

Example 6: Determine the equation of a right circular cone with vertex at origin and the guiding curve circle passing through the points $(1, 2, 2), (1, -2, 2), (2, -1, -2)$.

Solution: Let l, m, n be the DC's of OL the axis of the cone. Let θ be the semi-vertical angle. Let $A(1, 2, 2), B(1, -2, 2), C(2, -1, -2)$ be the three points on the guiding circle. Then the lines OA, OB, OC make the same angle θ with the axis OL . The DC's of OA, OB, OC are proportional to

ANALYTICAL SOLID GEOMETRY — 3.29

(1, 2, 2)(1, -2, 2)(2, -1, -2) respectively. Then

$$\cos \theta = \frac{l(1) + m(2) + n(2)}{\sqrt{l^2 + m^2 + n^2} \cdot \sqrt{1 + 4 + 4}} = \frac{l + 2m + 2n}{3} \quad (1)$$

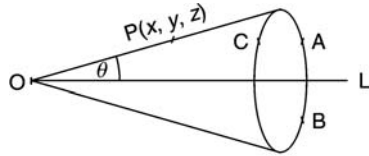

Fig. 3.19

Similarly,

$$\cos \theta = \frac{l(1) + m(-2) + n(2)}{\sqrt{l^2 + m^2 + n^2} \cdot \sqrt{1 + 4 + 4}} = \frac{l - 2m + 2n}{3} \quad (2)$$

$$\cos \theta = \frac{2l - m - 2n}{3} \quad (3)$$

From (1) and (2), $4m = 0$ or $m = 0$.

From (2) and (3), $l + m - 4n = 0, l - 4n = 0$ or $l = 4n$.

DC's $\frac{l}{4} = \frac{m}{0} = \frac{n}{1}$ or $\frac{l}{\frac{4}{\sqrt{17}}} = \frac{m}{0} = \frac{n}{\frac{1}{\sqrt{17}}}$.

From (1) $\cos \theta = \frac{\frac{4}{\sqrt{17}} + 2 \cdot 0 + 2 \cdot \frac{1}{\sqrt{17}}}{3} = \frac{2}{\sqrt{17}}$.

Equation of right circular cone is

$$(l^2 + m^2 + n^2)(x^2 + y^2 + z^2) \cos^2 \theta = (lx + my + nz)^2$$

$$\left(\frac{16}{17} + 0 + \frac{1}{17}\right)(x^2 + y^2 + z^2) \frac{4}{17} = \left(\frac{4}{\sqrt{17}}x + 0 + \frac{1}{\sqrt{17}}z\right)^2$$

$$4(x^2 + y^2 + z^2) = (4x + z)^2$$

$$12x^2 - 4y^2 - 3z^2 + 8xz = 0$$

is the required equation of the cone.

EXERCISE

- Find the equation of the cone whose vertex is (3, 1, 2) and base circle is $2x^2 + 3y^2 = 1, z = 1$.

Ans. $2x^2 + 3y^2 + 20z^2 - 6yz - 12xz + 12x + 6y - 38z + 17 = 0$

- Find the equation of the cone whose vertex is origin and guiding curve is $\frac{x^2}{4} + \frac{y^2}{9} + \frac{z^2}{1} = 1, x + y + z = 1$.

Ans. $27x^2 + 32y^2 + 72(xy + yz + zx) = 0$.

- Determine the equation of the cone with vertex at origin and guiding curve $x^2 + y^2 + z^2 - x - 1 = 0, x^2 + y^2 + z^2 + y - z = 0$.

Hint: Guiding curve is circle in plane $x + y = 1$. Rewrite $x^2 + y^2 + z^2 - x(x + y) - (x + y)^2 = 0$.

Ans. $x^2 + 3xy - z^2 = 0$

- Show that the equation of cone with vertex at origin and base circle $x = a, y^2 + z^2 = b^2$ is $a^2(y^2 + z^2) = b^2x^2$. Further prove that the section of the cone by a plane parallel to the XY-plane is a hyperbola.

Ans. $b^2x^2 - a^2y^2 = a^2c^2, z = c$ (put $z = c$ in equation of cone)

- Find the equation of a cone with vertex at origin and guiding curve is the circle passing through the X, Y, Z intercepts of the plane $\frac{x}{a} + \frac{y}{b} + \frac{z}{c} = 1$.

Ans. $a(b^2 + c^2)yz + b(c^2 + a^2)zx + c(a^2 + b^2)xy = 0$

- Write the equation of the cone whose vertex is (1, 1, 0) and base is $y^2 + z^2 = 9, x = 0$.

Hint: Substitute $(0, 1 - \frac{m}{l}, -\frac{n}{l})$ in base curve and eliminate $\frac{m}{l} = \frac{y-1}{x-1}, \frac{n}{l} = \frac{z}{z-1}$.

Ans. $x^2 + y^2 + z^2 - 2xy = 0$

Right circular cone (R.C.C.)

- Find the equation of R.C.C. with vertex at (2, 3, 1), axis parallel to the line $-x = \frac{y}{2} = z$ and one of its generators having DC's proportional to (1, -1, 1).

Hint: $\cos \theta = \frac{-1-2+1}{\sqrt{6}\sqrt{3}}, l = -1, m = 2, n = 1, \alpha = 2, \beta = 3, \gamma = 1$.

Ans. $x^2 - 8y^2 + z^2 + 12xy - 12yz + 6zx - 46x + 36y + 22z - 19 = 0$

- Determine the equation of R.C.C. with vertex at origin and passes through the point (1, 1, 2) and axis line $\frac{x}{2} = \frac{-y}{4} = \frac{z}{3}$.

3.30 — ENGINEERING MATHEMATICS

Hint: $\cos \theta = \frac{2-4+6}{\sqrt{6}\sqrt{29}}$, DC's of generator: 1, 1, 2, axis: 2, -4, 3

Ans. $4x^2 + 40y^2 + 19z^2 - 48xy - 72yz + 36xz = 0$

9. Find the equation of R.C.C. whose vertex is origin and whose axis is the line $\frac{x}{1} = \frac{y}{2} = \frac{z}{3}$ and which has semi- vertical angle of 30°

Hint: $\cos 30 = \frac{\sqrt{3}}{2} = \frac{x(1)+y(2)+z(3)}{\sqrt{(x^2+y^2+z^2)}\sqrt{1+4+9}}$

Ans. $19x^2 + 13y^2 + 3z^2 - 8xy - 24yz - 12zx = 0$

10. Obtain the equation of R.C.C. generated when the straight line $2y + 3z = 6, x = 0$ revolves about z-axis.

Hint: Vertex (0, 0, 2), generator $\frac{x}{0} = \frac{y}{3} = \frac{z-2}{-2}$, $\cos \theta = -\frac{2}{\sqrt{13}}$.

Ans. $4x^2 + 4y^2 - 9z^2 + 36z - 36 = 0$

11. Lines are drawn from the origin with DC's proportional to (1, 2, 2), (2, 3, 6), (3, 4, 12). Find the equation of R.C.C.

Hint: $\cos \alpha = \frac{l+2m+2n}{3} = \frac{2l+3m+6n}{7} = \frac{3l+4m+12n}{13}$
 $\frac{l}{-1} = \frac{m}{1} = \frac{n}{1}$, $\cos \alpha = \frac{1}{\sqrt{3}}$, DC's of axis: -1, 1, 1.

Ans. $xy - yz + zx = 0$

12. Determine the equation of the R.C.C. generated by straight lines drawn from the origin to cut the circle through the three points (1, 2, 2), (2, 1, -2), and (2, -2, 1).

Hint: $\cos \alpha = \frac{l+2m+2n}{3} = \frac{2l+m-2n}{3} = \frac{2l-2m+n}{3}$ $\frac{l}{5} = \frac{m}{1} = \frac{n}{1}$, $\cos \alpha = \frac{3+2+2}{3\sqrt{27}} = \frac{1}{\sqrt{3}}$.

Ans. $8x^2 - 4y^2 - 4z^2 + 5xy + 5zx + yz = 0$

3.7 THE RIGHT CIRCULAR CYLINDER

A cylinder is the surface generated by a straight line (known as **generator**) which is parallel to a fixed straight line (known as **axis**) and satisfies a condition; for example, it may intersect a fixed curve (known as the **guiding curve**) or touch a given surface. A **right circular cylinder** is a cylinder whose surface is generated by revolving the generator at a fixed distance (known as the **radius**) from the axis; i.e., the guiding curve in this case is a circle. In fact, the

intersection of the right circular cylinder with any plane perpendicular to axis of the cylinder is a circle.

Equation of a cylinder with generators parallel to the line $\frac{x}{l} = \frac{y}{m} = \frac{z}{n}$ and guiding curve conic $ax^2 + by^2 + 2hxy + 2gx + 2fy + c = 0, z = 0$.

Let $P(x_1, y_1, z_1)$ be any point on the cylinder. The equation of the generator through $P(x_1, y_1, z_1)$ which is parallel to the given line

$$\frac{x}{l} = \frac{y}{m} = \frac{z}{n} \tag{1}$$

is
$$\frac{x-x_1}{l} = \frac{y-y_1}{m} = \frac{z-z_1}{n} \tag{2}$$

Since (2) meets the plane $z = 0$,

$$\therefore \frac{x-x_1}{l} = \frac{y-y_1}{m} = \frac{0-z_1}{n}$$

or
$$x = x_1 - \frac{l}{n}z_1, y = y_1 - \frac{m}{n}z_1 \tag{3}$$

Since this point (3) lies on the conic

$$ax^2 + by^2 + 2hxy + 2gx + 2fy + c = 0 \tag{4}$$

substitute (3) in (4). Then

$$\begin{aligned} &a \left(x_1 - \frac{l}{n}z_1\right)^2 + b \left(y_1 - \frac{m}{n}z_1\right)^2 + \\ &+ 2h \left(x_1 - \frac{l}{n}z_1\right) \left(y_1 - \frac{m}{n}z_1\right) + 2g \left(x_1 - \frac{l}{n}z_1\right) + \\ &+ 2f \left(y_1 - \frac{m}{n}z_1\right) + c = 0. \end{aligned}$$

The required equation of the cylinder is

$$\begin{aligned} &a(nx-lz)^2 + b(ny-mz)^2 + 2h(nx-lz)(ny-mz) + \\ &+ 2ng(nx-lz) + 2nf(ny-mz) + cn^2 = 0 \end{aligned} \tag{5}$$

where the subscript 1 is dropped because (x_1, y_1, z_1) is any general point on the cylinder.

Corollary 1: The equation of a cylinder with axis parallel to z-axis is obtained from (5) by putting $l = 0, m = 0, n = 1$ which are the DC's of z-axis: i.e.,

$$ax^2 + by^2 + 2hxy + 2gx + 2fy + c = 0$$

which is **free** from z.

Thus the equation of a cylinder whose axis is parallel to x-axis (y-axis or z-axis) is obtained by eliminating the variable x (y or z) from the equation of the conic.

ANALYTICAL SOLID GEOMETRY — 3.31

Equation of a right circular cylinder:

- a. **Standard form:** with z-axis as axis and of radius a . Let $P(x, y, z)$ be any point on the cylinder. Then M the foot of the perpendicular PM has $(0, 0, z)$ and $PM = a$ (given). Then

$$a = PM = \sqrt{(x - 0)^2 + (y - 0)^2 + (z - z)^2}$$

$$x^2 + y^2 = a^2$$

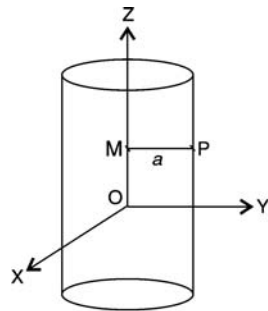

Fig. 3.20

Corollary 2: Similarly, equation of right circular cylinder with y-axis is $x^2 + z^2 = a^2$, with x-axis is $y^2 + z^2 = a^2$.

- b. **General form** with the line $\frac{x-\alpha}{l} = \frac{y-\beta}{m} = \frac{z-\gamma}{n}$ as axis and of radius a .

Axis AB passes through the point (α, β, γ) and has DR's l, m, n . Its DC's are $\frac{l}{k}, \frac{m}{k}, \frac{n}{k}$ where $k = \sqrt{l^2 + m^2 + n^2}$.

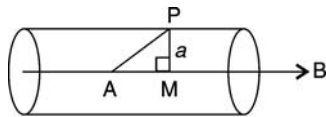

Fig. 3.21

From the right angled triangle APM

$$AP^2 = PM^2 + AM^2$$

$$(x - \alpha)^2 + (y - \beta)^2 + (z - \gamma)^2$$

$$= a^2 + \left[l(x - \alpha) + m(y - \beta) + n(z - \gamma) \right]^2$$

which is the required equation of the cylinder (Here AM is the projection of AP on the line AB is equal to $l(x - \alpha) + m(y - \beta) + n(z - \gamma)$).

Enveloping cylinder of a sphere is the locus of the tangent lines to the sphere which are parallel to a given line. Suppose

$$x^2 + y^2 + z^2 = a^2 \tag{1}$$

is the sphere and suppose that the generators are parallel to the given line

$$\frac{x}{l} = \frac{y}{m} = \frac{z}{n} \tag{2}$$

Then for any point $P(x_1, y_1, z_1)$ on the cylinder, the equation of the generating line is

$$\frac{x - x_1}{l} = \frac{y - y_1}{m} = \frac{z - z_1}{n} \tag{3}$$

Any general point on (3) is

$$(x_1 + lr, \quad y_1 + mr, \quad z_1 + nr) \tag{4}$$

By substituting (4) in (1), we get the points of intersection of the sphere (1) and the generating line (3) i.e.,

$$(x_1 + lr)^2 + (y_1 + mr)^2 + (z_1 + nr)^2 = a^2$$

Rewriting as a quadratic in r , we have

$$(l^2 + m^2 + n^2)r^2 + 2(lx_1 + my_1 + nz_1)r + (x_1^2 + y_1^2 + z_1^2 - a^2) = 0 \tag{5}$$

If the roots of (5) are equal, then the generating line (3) meets (touches) the sphere in a single point i.e., when the discriminant of the quadratic in r is zero.

or $4(lx_1 + my_1 + nz_1)^2 - 4(l^2 + m^2 + n^2) \times (x_1^2 + y_1^2 + z_1^2 - a^2) = 0$

Thus the required equation of the enveloping cylinder is

$$(lx + my + nz)^2 = (l^2 + m^2 + n^2)(x^2 + y^2 + z^2 - a^2)$$

where the subscript 1 is dropped to indicate that (x, y, z) is a general point on the cylinder.

WORKED OUT EXAMPLES

Example 1: Find the equation of the quadratic cylinder whose generators intersect the curve $ax^2 +$

3.32 — ENGINEERING MATHEMATICS

$by^2 + cz^2 = k, lx + my + nz = p$ and parallel to the y -axis. Deduce the case for $x^2 + y^2 + z^2 = 1$ and $x + y + z = 1$ and parallel to y -axis

Solution: Eliminate y between

$$ax^2 + by^2 + cz^2 = k \tag{1}$$

and $lx + my + nz = p \tag{2}$

Solving (2) for y , we get

$$y = \frac{p - lx - nz}{m} \tag{3}$$

Substitute (3) in (1), we have

$$ax^2 + b\left(\frac{p - lx - nz}{m}\right)^2 + cz^2 = k.$$

The required equation of the cylinder is

$$(am^2 + l^2)x^2 + (bn^2 + m^2c)z^2 - 2pblx - 2npbz + 2blnxz + (bp^2 - m^2k) = 0.$$

Deduction: Put $a = 1, b = 1, c = 1, k = 1, l = m = n = p = 1$

$$2x^2 + 2z^2 - 2x - 2z + 2xz = 0$$

or $x^2 + z^2 + xz - x - z = 0.$

Example 2: If l, m, n are the DC's of the generators and the circle $x^2 + y^2 = a^2$ in the XY -plane is the guiding curve, find the equation of the cylinder. Deduce the case when $a = 4, l = 1, m = 2, n = 3.$

Solution: For any point $P(x_1, y_1, z_1)$ on the cylinder, the equation of the generating line through P is

$$\frac{x - x_1}{l} = \frac{y - y_1}{m} = \frac{z - z_1}{n} \tag{1}$$

Since the line (1) meets the guiding curve $x^2 + y^2 = a^2, z = 0,$

$$\frac{x - x_1}{l} = \frac{y - y_1}{m} = \frac{0 - z_1}{n}$$

or $x = x_1 - \frac{lz_1}{n}, \quad y = y_1 - \frac{mz_1}{n} \tag{2}$

This point (2) lies on the circle $x^2 + y^2 = a^2$ also. Substituting (2) in the equation of circle, we have

$$\left(x_1 - \frac{lz_1}{n}\right)^2 + \left(y_1 - \frac{mz_1}{n}\right)^2 = a^2$$

or $(nx - lz)^2 + (ny - mz)^2 = n^2a^2$

is the equation of the cylinder.

Deduction: Equation of cylinder whose generators are parallel to the line $\frac{x}{1} = \frac{y}{2} = \frac{z}{3}$ and pass through the curve $x^2 + y^2 = 16, z = 0.$ With $a = 4, l = 1, m = 2, n = 3,$ the required equation of the cylinder is

$$(3x - z)^2 + (3y - 2z)^2 = 9(16) = 144$$

or $9x^2 + 9y^2 + 5z^2 - 6zx - 12yz - 144 = 0.$

Example 3: Find the equation of the right circular cylinder of radius 3 and the line $\frac{x-1}{2} = \frac{y-3}{2} = \frac{z-5}{-1}$ as axis.

Solution: Let $A(1, 3, 5)$ be the point on the axis and DR's of AB are $2, 2, -1$ or DC's of AB are $\frac{2}{3}, \frac{2}{3}, -\frac{1}{3}.$ Radius $PM = 3$ given. Since AM is the projection of AP on AB , we have

$$AM = \frac{2}{3}(x - 1) + \frac{2}{3}(y - 3) - \frac{1}{3}(z - 5)$$

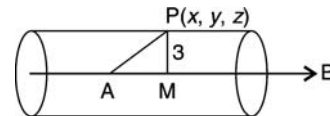

Fig. 3.22

From the right angled triangle APM

$$AP^2 = AM^2 + MP^2$$

$$(x - 1)^2 + (y - 3)^2 + (z - 5)^2$$

$$= \left[2\frac{(x - 1)}{3} + 2\frac{(y - 3)}{3} - 1\frac{(z - 5)}{3}\right]^2 + 9$$

$$9[x^2 + 1 - 2x + y^2 + 9 - 6y + z^2 + 25 - 10z]$$

$$= [2x + 2y - z - 3]^2 + 81$$

$$9[x^2 + y^2 + z^2 - 2x - 6y - 10z + 35]$$

$$= [4x^2 + 4y^2 + z^2 + 9 + 8xy - 4xz - 12x$$

$$- 4yz - 12y + 6z] + 81$$

is the required equation of the cylinder.

Example 4: Find the equation of the enveloping cylinder of the sphere $x^2 + y^2 + z^2 - 2y - 4z - 11 = 0$ having its generators parallel to the line $x = -2y = 2z.$

Solution: Let $P(x_1, y_1, z_1)$ be any point on the cylinder. Then the equation of the generating line

ANALYTICAL SOLID GEOMETRY — 3.33

through P and parallel to the line $x = -2y = 2z$ or

$$\frac{x}{1} = \frac{y}{-\frac{1}{2}} = \frac{z}{\frac{1}{2}} \text{ is}$$

$$\frac{x - x_1}{1} = \frac{y - y_1}{-\frac{1}{2}} = \frac{z - z_1}{\frac{1}{2}} \quad (1)$$

Any general point on (1) is

$$\left(x_1 + r, \quad y_1 - \frac{1}{2}r, \quad z_1 + \frac{1}{2}r\right) \quad (2)$$

The points of intersection of the line (1) and the sphere

$$x^2 + y^2 + z^2 - 2y - 4z - 11 = 0 \quad (3)$$

are obtained by substituting (2) in (3).

$$\begin{aligned} (x_1 + r)^2 + \left(y_1 - \frac{1}{2}r\right)^2 + \left(z_1 + \frac{1}{2}r\right)^2 - 2\left(y_1 - \frac{1}{2}r\right) \\ - 4\left(z_1 + \frac{1}{2}r\right) - 11 = 0 \end{aligned}$$

Rewriting this as a quadratic in r

$$\begin{aligned} \frac{3}{2}r^2 + (2x_1 - y_1 + z_1 - 1)r \\ + (x_1^2 + y_1^2 + z_1^2 - 2y_1 - 4z_1 - 11) = 0 \quad (4) \end{aligned}$$

The generator touches the sphere (3) if (4) has equal roots i.e., discriminant is zero or

$$\begin{aligned} (2x_1 - y_1 + z_1 - 1)^2 \\ = 4 \cdot \frac{3}{2} \cdot (x_1^2 + y_1^2 + z_1^2 - 2y_1 - 4z_1 - 11). \end{aligned}$$

The required equation of the cylinder is

$$\begin{aligned} 2x^2 + 5y^2 + 5z^2 + 4xy - 4xz + 2yz \\ + 4x - 14y - 22z - 67 = 0. \end{aligned}$$

EXERCISE

1. Find the equation of the quadratic cylinder whose generators intersect the curve

a. $ax^2 + by^2 = 2z, lx + my + nz = p$ and are parallel to z -axis.

b. $ax^2 + by^2 + cz^2 = 1, lx + my + nz = p$ and are parallel to x -axis.

Hint: Eliminate z

Ans. a. $n(ax^2 + by^2) + 2lx + 2my - 2p = 0$

Hint: Eliminate x .

Ans. b. $(bl^2 + am^2)y^2 + (cl^2 + an^2)z^2 + 2amnyz - 2ampy - 2anpz + (ap^2 - l^2) = 0$

2. If l, m, n are the DC's of the generating line and the circle $x^2 + z^2 = a^2$ in the zx -plane is the guiding curve, find the equation of the sphere.

Ans. $(mx - ly)^2 + (mz - ny)^2 = a^2m^2$

Find the equation of a right circular cylinder (4 to 9)

4. Whose axis is the line $\frac{x-1}{2} = \frac{y+3}{-1} = \frac{z-2}{5}$ and radius is 2 units.

Ans. $26x^2 + 29y^2 + 5z^2 + 4xy + 10yz - 20zx + 150y + 30z + 75 = 0$

5. Having for its base the circle $x^2 + y^2 + z^2 = 9, x - y + z = 3$.

Ans. $x^2 + y^2 + z^2 + xy + yz - zx - 9 = 0$

6. Whose axis passes through the point $(1, 2, 3)$ and has DC's proportional to $(2, -3, 6)$ and of radius 2.

Ans. $45x^2 + 40y^2 + 13z^2 + 36yz - 24zx + 12xy - 42x - 280y - 126z + 294 = 0.$

3.34 — ENGINEERING MATHEMATICS

7. Whose axis is the line $\frac{x-1}{2} = \frac{y-2}{1} = \frac{z-3}{2}$ and radius 2 units.

Ans. $5x^2 + 8y^2 + 5z^2 - 4yz - 8zx - 4xy + 22x - 16y - 14z - 10 = 0$

8. The guiding curve is the circle through the three points (1, 0, 0), (0, 1, 0), (0, 0, 1).

Ans. $x^2 + y^2 + z^2 - xy - yz - zx = 1$

9. The directing curve is $x^2 + z^2 - 4x - 2z + 4 = 0$, $y = 0$ and whose axis contains the point (0, 3, 0). Also find the area of the section of the cylinder by a plane parallel to xz -plane.

Hint: Centre of circle (2, 0, 1) radius: 1

Ans. $9x^2 + 5y^2 + 9z^2 + 12xy + 6yz - 36x - 30y - 18z + 36 = 0, \pi$

10. Find the equation of the enveloping cylinder of the sphere $x^2 + y^2 + z^2 - 2x + 4y = 1$, having its generators parallel to the line $x = y = z$.

Ans. $x^2 + y^2 + z^2 - xy - yz - zx - 2x + 7y + z - 2 = 0.$