



South Valley University

Faculty of Science

Physics Department

# General physics ( 101 PhY )

فيزياء عامة ( 101 ف )

**PART ( 1 ) Electricity**

الفرقة الاولى

شعبة الجيولوجيا

الدكتورة / انشراح محمد سعد الدين حمادة

قسم الفيزياء

**Chapter (1)**

# **Electrostatic**

**Principles and Applications**

# Introduction to Electrostatic

## 1.1 Understanding Static Electricity

### 1.2 Properties of electrostatic

1.2.1 Electric charge

1.2.2 Conductor and insulator

1.2.3 Positive and negative charge

1.2.4 Charge is conserved

1.2.5 Charge and matter

1.2.6 Charge is Quantized

We have all seen the strange device, known as a *Van De Graaff Generator*, that makes your hair stand on end.

The device looks like a big aluminum ball mounted on a pedestal, and has the effect pictured on the right. Have you ever wondered what this device is, how it works, why it was invented, Surely it wasn't invented to make children's hair stand on end... Or have you ever shuffled your feet across the carpet on a dry winter day and gotten the shock of your life when you touched something metal? Have you ever wondered about static electricity and static cling? If any of these questions have ever crossed your mind, then here we will be amazingly interesting as we discuss Van de Graaff generators and static electricity in general.

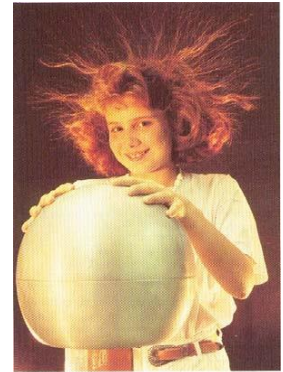

## 1.1 Understanding Static Electricity

To understand the Van de Graaff generator and how it works, you need to understand static electricity. Almost all of us are familiar with static electricity because we can see and feel it in the winter. On dry winter days, static electricity can build up in our bodies and cause a spark to jump from our bodies to pieces of metal or other people's bodies. We can see, feel and hear the sound of the spark when it jumps.

In science class you may have also done some experiments with static electricity. For example, if you rub a glass rod with a silk cloth or if you rub a piece of amber with wool, the glass and amber will develop a static charge that can attract small bits of paper or plastic.

To understand what is happening when your body or a glass rod develops a static charge, you need to think about the atoms that make

up everything we can see. All matter is made up of atoms, which are themselves made up of charged particles. Atoms have a nucleus consisting of neutrons and protons. They also have a surrounding "shell" which is made up electrons. Typically matter is neutrally charged, meaning that the number of electrons and protons are the same. If an atom has more electrons than protons, it is negatively charged. Likewise, if it has more protons than electrons, it is positively charged. Some atoms hold on to their electrons more tightly than others do. How strongly matter holds on to its electrons determines its place in the Triboelectric Series. If a material is more apt to give up electrons when in contact with another material, it is more positive on the Triboelectric Series. If a material is more to "capture" electrons when in contact with another material, it is more negative on the Triboelectric Series. The following table shows you the Triboelectric Series for many materials you find around the house. Positive items in the series are at the top, and negative items are at the bottom :

- Human Hands (usually too moist though) (very positive)
- Rabbit Fur
- Glass
- Human Hair
- Nylon
- Wool
- Fur
- Lead
- Silk
- Aluminum
- Paper
- Cotton
- Steel (neutral)
- Wood
- Amber
- Hard Rubber

- Nickel, Copper
- Brass, Silver
- Gold, Platinum
- Polyester
- Styrene (Styrofoam)
- Saran Wrap
- Polyurethane
- Polyethylene (like scotch tape)
- Polypropylene
- Vinyl (PVC)
- Silicon
- Teflon (very negative)

The relative position of two substances in the Triboelectric series tells you how they will act when brought into contact.

Glass rubbed by silk causes a charge separation because they are several positions apart in the table.

The same applies for amber and wool.

The farther the separation in the table, the greater the effect.

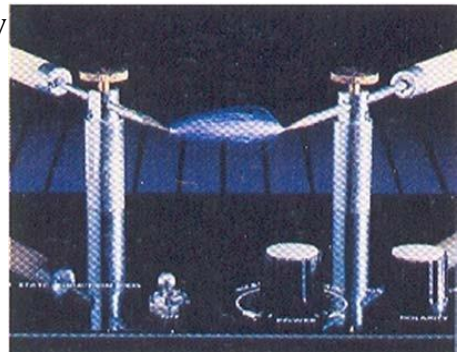

When two non-conducting materials come into contact with each other, a chemical bond, known as adhesion, is formed between the two materials. Depending on the triboelectric properties of the materials, one material may "capture" some of the electrons from the other material. If the two materials are now separated from each other, a charge imbalance will occur. The material that captured the electron is now negatively charged and the material that lost an electron is now positively charged. This charge imbalance is where "static electricity" comes from. The term "static" electricity is deceptive, because it implies "no motion", when in reality it is very common and necessary for charge imbalances to flow. The spark you feel when you touch a doorknob is an example of such flow. You

may wonder why you don't see sparks every time you lift a piece of paper from your desk. The amount of charge is dependent on the materials involved and the amount of surface area that is connecting them. Many surfaces, when viewed with a magnifying device, appear rough or jagged. If these surfaces were flattened to allow for more surface contact to occur, the charge (voltage) would most definitely increase. Another important factor in electrostatics is humidity. If it is very humid, the charge imbalance will not remain for a useful amount of time. Remember that humidity is the measure of moisture in the air. If the humidity is high, the moisture coats the surface of the material providing a low-resistance path for electron flow. This path allows the charges to "recombine" and thus neutralize the charge imbalance. Likewise, if it is very dry, a charge can build up to extraordinary levels, up to tens of thousands of volts!

Think about the shock you get on a dry winter day. Depending on the type of sole your shoes have and the material of the floor you walk on, you can build up enough voltage to cause the charge to jump to the doorknob, thus leaving you neutral. You may remember the old "Static Cling" commercial. Clothes in the dryer build up an electrostatic charge. The dryer provides a low moisture environment that rotates, allowing the clothes to continually contact and separate from each other. The charge can easily be high enough to cause the material to attract and "stick" to oppositely charged surfaces (your body or other clothes in this case). One method you could use to remove the "static" would be to lightly mist the clothes with some water. Here again, the water allows the charge to leak away, thus leaving the material neutral.

It should be noted that when dirt is in the air, the air will break down much more easily in an electric field. This means that the dirt allows the air to become ionized more easily. Ionized air is actually air that has been stripped of its electrons. When this occurs, it is said to be **plasma**, which is a pretty good conductor. Generally speaking, adding impurities to air improves its conductivity. You should now realize that having impurities in the air has the same effect as having moisture in the air. Neither condition is at all desirable for

electrostatics. The presence of these impurities in the air, usually means that they are also on the materials you are using. The air conditions are a good gauge for your material conditions, the materials will generally break down like air, only much sooner.

[Note: Do not make the mistake of thinking that electrostatic charges are caused by friction. Many assume this to be true. Rubbing a balloon on your head or dragging your feet on the carpet will build up a charge.

Electrostatics and friction are related in that they both are products of adhesion as discussed above. Rubbing materials together can increase the electrostatic charge because more surface area is being contacted, but friction itself has nothing to do with the electrostatic charge]

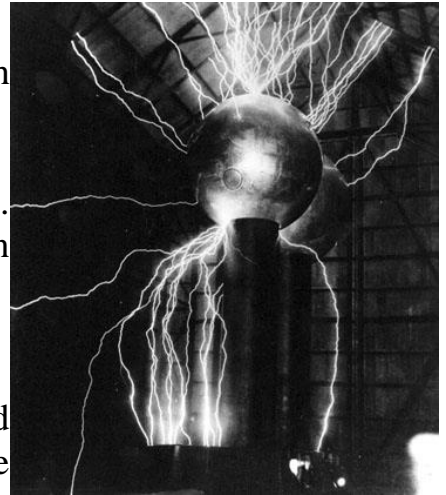

## 1- 2 Properties of electrostatic

### 1 -2 -1 Electric charge

If a rod of ebonite is rubbed with fur, or a fountain pen with a coat-sleeve, it gains the power to attract light bodies, such as pieces of paper or tin foil. The discovery that a body could be made attractive by rubbing is attributed to Thales (640-548 B.C). He seems to have been led to it through the Greeks' practice of spinning silk with an amber spindle; the rubbing of the spindle cause the silk to be attracted to it. The Greek word of amber is *electron*, and a body made attractive by rubbing is said to be *electrified* or *charged*. The branch of electricity is called *Electrostatics*.

#### - Characteristics of charge

- 1- Two types of charges, positive and negative
- 2- Charge is conserved



Charges can be separated but cannot be created or destroyed.

3 - Like charges repel and unlike changes attract

## 1- 2- 2 Conductor and insulator

### Types of Materials

#### 1- Conductors

Example: metals, copper etc. charges are free to move.

#### 2 - Insulators:

Example: Rubber, plastic etc  
charges are not free to move.

#### 3- Semiconductors:

Example: Silicon, Germanium  
movement of charges can be controlled by temperature or doping of the material.

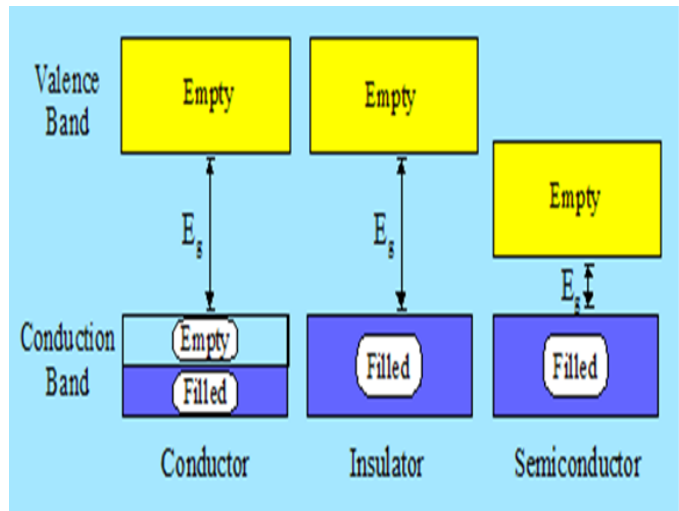

Application: electronic devices

#### 4- Photoconductors:

Example: Selenium

**In darkness:** Insulator (holds charge)

**Exposed to light:** conductor (charge leaks away)

Application: photocopier, laser printer

### 1.2.3 Positive and negative charge

How do we know there are two types of charge ?When various materials are rubbed together in controlled ways, certain combinations of materials always produce positive charge on one material and negative on the other . For example ,When glass is rubbed with silk ,the glass become positively charged and the silk negatively charge. Since the glass and silk have opposite charge ,they attract one another like clothes that have rubbed together in a dryer .Two glass rods rubbed in this manner will repel one another .since each rod has positive charge on it .Similarly, two silk cloths so rubbed will repel , since both cloths have negative charge .

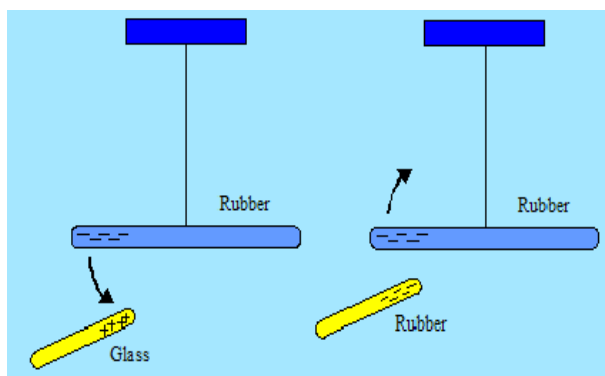

**Figure 1.1**

**Unlike charges attract one another and like charge repel one another**

Like charge repel one another and unlike charges attract one another as shown in figure 1.1 where a suspended rubber rod is negatively charged is attracted to the glass rod. But another negatively charged rubber rod will repel the suspended rubber rod.

### **1-2- 4The Law of Conservation of Charge ( قانون حفظ الشحنة )**

The **law of conservation of charge** is easily observed in the induction charging process. Considering the example above, one can look at the two spheres as a system. Prior to the charging process, the overall charge of the system was zero. There were equal numbers of protons and electrons

within the two spheres. In diagram ii. above, electrons were induced into moving from sphere A to sphere B. At this point, the individual spheres become charged. The quantity of positive charge on sphere A equals the quantity of negative charge on sphere B. If sphere A has 1000 units of positive charge, then sphere B has 1000 units of negative charge. Determining the overall charge of the system is easy arithmetic; it is simply the sum of the charges on the individual spheres.

Overall Charge of Two Spheres = +1000 units + (-1000 units) = 0 units

The overall charge on the system of two objects is the same after the charging process as it was before the charging process. Charge is neither created nor destroyed during this charging process; it is simply transferred from one object to the other object in the form of electrons.

### 1-2-5 Charge and Matter

Electric charge is a characteristic of sub-atomic particles.

#### Simple View

An atom is composed of 3 kinds of particles:

protons , electrons and neutrons.

Particle	Symbol	Charge	Mass
Proton	$p$	$1.6 \times 10^{-19} \text{C}$	$1.67 \times 10^{-27} \text{K}$
Neutron	$n$	0	$1.67 \times 10^{-27} \text{K}$
Electron	$e$	$-1.6 \times 10^{-19} \text{C}$	$1.67 \times 10^{-31} \text{K}$

In General, these particles

- neither created nor destroyed,
- electrons can be displaced from one atom to another.

Electron removed – result → positive ion

Electron added – result → negative ion

## 1-2- 6 Types of Charging

### 1 - Charging by Contact ( or conduction )

Charging by conduction involves the contact of a charged object to a neutral object. Suppose that a positively charged aluminum plate is touched to a neutral metal sphere. The neutral metal sphere becomes charged as the result of being contacted by the charged aluminum plate. Or suppose that a negatively charged metal sphere is touched to the top plate of a neutral needle electroscope. The neutral electroscope becomes charged as the result of being contacted by the metal sphere. And finally, suppose that an uncharged physics student stands on an insulating platform and touches a negatively charged Van de Graaff generator. The neutral physics student becomes charged as the result of contact with the Van de Graaff generator. Each of these examples involves contact between a charged object and a neutral object. In contrast to induction, where the charged object is brought near but never contacted to the object being charged, conduction charging involves making the physical connection of the charged object to the neutral object. Because charging by conduction involves contact, it is often called **charging by contact**.

## Charging a Neutral Object by Conduction

Diagram i.

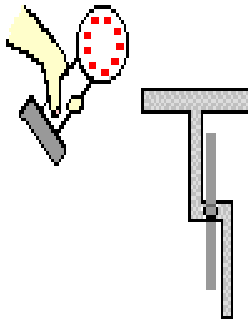

A metal sphere with an excess of - charge is brought near to a neutral electroscope.

Diagram ii.

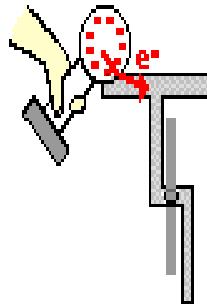

Upon contact,  $e^-$  move from the sphere to the electroscope and spread about uniformly.

Diagram iii.

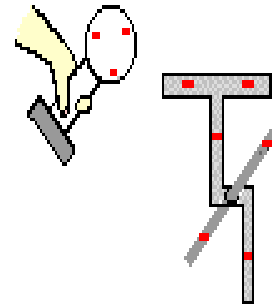

The metal sphere now has less excess - charge and the electroscope now has a - charge.

## 2. Charging by Contact (or Conduction)

- The process of giving one object a net electric charge by placing it in contact w/another object that is already charged is known as **charging by contact**.
- Result: two objects with same charge

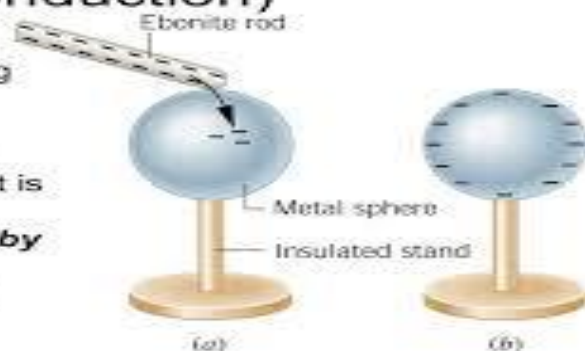

## 2 – Charging by INDUCTION

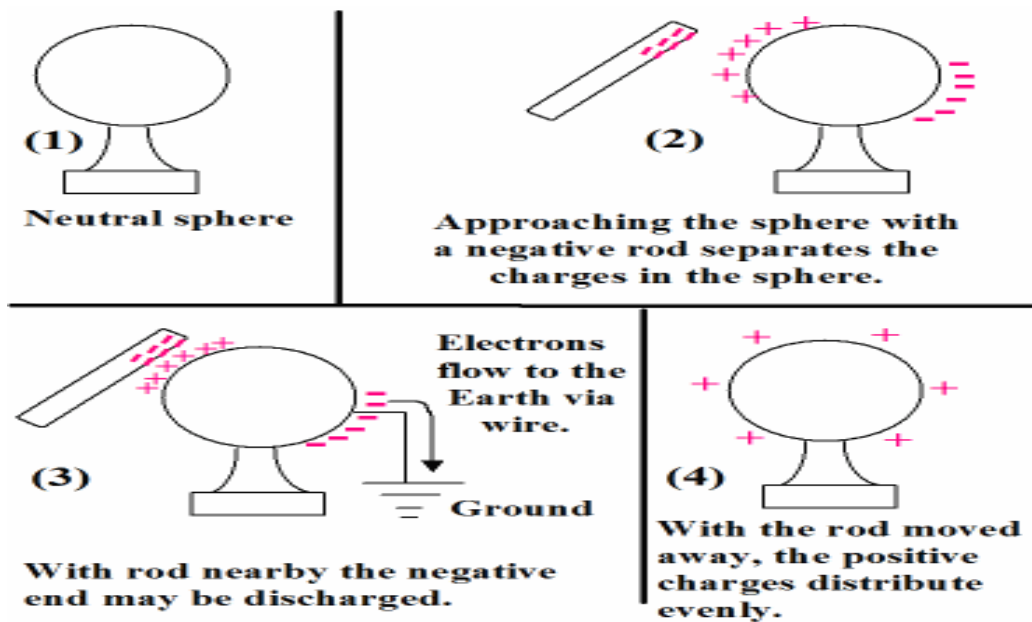

Let us consider a neutral sphere made with the metal. Since metal is a good conductor of electricity, so we have chosen the object made from metal. The neutral sphere is placed on an insulator sheet as shown in diagram (right), so that the charge doesn't flow out from the system. As we can see in the figure 2; there is equal amount of positive and negative charge on the sphere (number of positive charge = 6 = number of negative charge) and hence, we can say that the object is neutral as shown in the first part of diagram.

In the second part of the diagram, we bring the negatively charged rod (rod shown in figure 3 & 4 having negative charge) near the sphere. Sphere have both positive and negative charge and as the rod is brought

near to the sphere, the negative charge in sphere are repelled by the rod (due to same charge) and move to the outer side of sphere. Number of positive charges are equal to the number of negative charges. We can say, that total charge on a system is zero.

In the third part of diagram, we ground the sphere and negative charge move to the ground. So only positive charge remains left. In the fourth part of diagram, positive charge evenly spread on the sphere.

**Note:** In Charge by Induction method objects are not in physically contact with each other while in remaining two methods objects are in physically contact with each other.

#### 18.4 Charging by Contact and by Induction

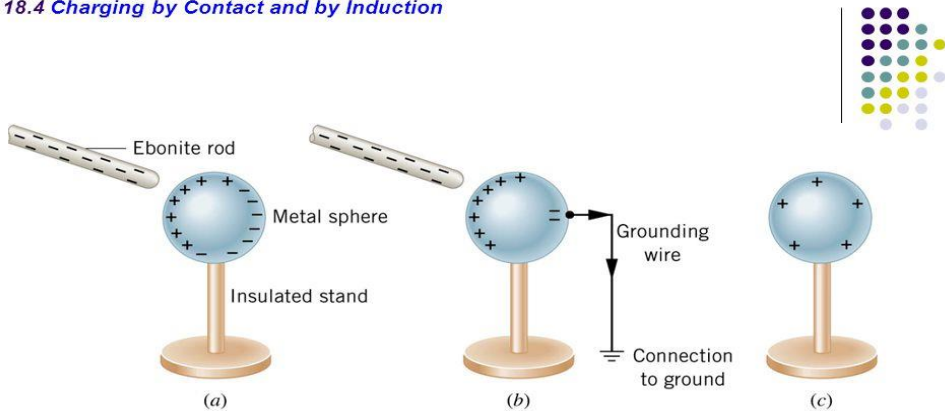

Charging by induction.

## **Chapter (2) Coulomb's law**

<b>2.1 Coulomb's Law</b>	<b>16</b>
<b>2.2 Calculation of the electric force</b>	<b>17</b>
<b>2.2.1 Electric force between two electric charges</b>	<b>23</b>
<b>2.2.2 Electric force between more than two electric charges</b>	<b>25</b>



## 2.1 Coulomb's Law

In 1785, Coulomb established the fundamental law of *electric force* between two stationary, charged particles.

Objects with electric charge attract and repel each other by exerting forces. Charges with the same sign repel, and charges with opposite signs attract. The magnitude of the electrostatic force between charges can be found using Coulomb's Law. The electrostatic force depends on the magnitude of the charges, the distance between them, and the Coulomb constant, which is  $k \cong 8.988 \times 10^9 \text{ N} \cdot \text{m}^2/\text{C}^2$ . The Coulomb constant can also be written in terms of the permittivity of free space,  $\epsilon_0$ . In that form, the Coulomb constant is  $k = 1/4\pi\epsilon_0$ . The values of the electric charges have units of Coulombs, C. Charges are often written as multiples of the smallest possible charge,  $e \cong 1.602 \times 10^{-19} \text{ C}$ .

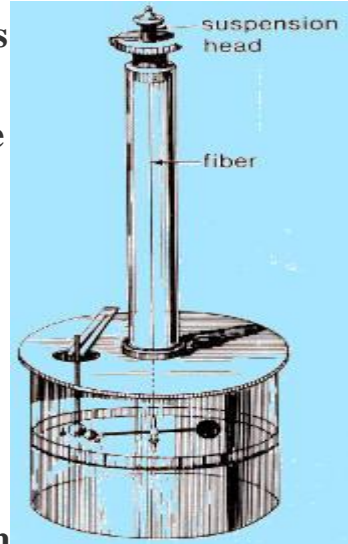

The unit of the electrostatic force is Newtons (N).

*electrostatic force* = (Coulomb constant)  $\frac{\text{absolute value of (charge 1)(charge 2)}}{(\text{distance between charges})^2}$

$$F = k \frac{|q_1 q_2|}{r^2}$$

$F$  = electrostatic force between two point charges ( $N = kg \cdot m/s^2$ )

$k = \text{Coulomb constant}$   $k = 1/4\pi\epsilon_0 \cong 8.988 \times 10^9 \text{ N} \cdot \text{m}^2/\text{C}^2$

$q_1$  = charge of the first point charge (C)

$q_2$  = charge of the second point charge (C)

$r$  = distance between charges (m)

Experiments show that an electric force has the following properties:

(1) The force is *inversely proportional* to the square of separation,  $r^2$ , between the two charged particles.

$$F \propto \frac{1}{r^2}$$

(2) The force is *proportional* to the product of charge  $q_1$  and the charge  $q_2$  on the particles.

$$F \propto q_1 q_2$$

(3) The force is *attractive* if the charges are of opposite sign and *repulsive* if the charges have the same sign. We can conclude that

$$F \propto \frac{q_1 q_2}{r^2}$$

$$\therefore F = K \frac{q_1 q_2}{r^2}$$

where  $K$  is the coulomb constant =  $9 \times 10^9 \text{ N} \cdot \text{m}^2/\text{C}^2$ .

The above equation is called *Coulomb's law*, which is used to calculate the force between electric charges. In that equation  $F$  is measured in Newton (N),  $q$  is measured in unit of coulomb (C) and  $r$  in meter (m). The constant  $K$  can be written as

$$K = \frac{1}{4\pi\epsilon_0}$$

where  $\epsilon_0$  is known as the **Permittivity constant of free spac** . ( ثابت السماحية الكهربائية للفراغ )

$$\epsilon_0 = 8.85 \times 10^{-12} \text{ C}^2/\text{N}\cdot\text{m}^2$$

$$K = \frac{1}{4\pi\epsilon_0} = \frac{1}{4\pi \times 8.85 \times 10^{-12}} = 9 \times 10^9 \text{ N}\cdot\text{m}^2/\text{C}^2$$

### Definition of *Coulomb's law*

: a statement in physics: the force of attraction or repulsion acting along a straight line between two electric charges is directly proportional to the product of the charges and inversely to the square of the distance between them

## 2.2 Calculation of the electric force

### 2.2.1 Electric force between two electric charges

The electric force between two electrons is the same as the electric force between two protons when they are placed at the same distance. This implies that the electric force does not depend on the mass of the particle. Instead, it depends on a new quantity: the electric charge.

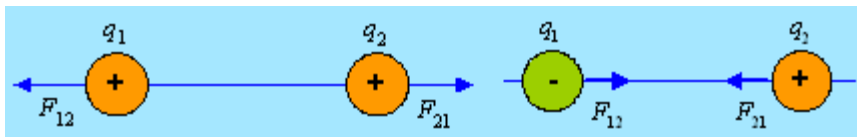

**Repulsive force**

*Figure 2.2(a)*

$$F_{12} = K \frac{q_1 q_2}{r^2} = F_{21}$$

*Figure 2.2(b)*

$$\vec{F}_{12} = -\vec{F}_{21}$$

**Example 2.1** Calculate the value of two equal charges if they repel one another with a force of 0.1N when situated 50cm apart in a vacuum. **Solution**

$$F = K \frac{q_1 q_2}{r^2}$$

Since  $q_1 = q_2$   
 $q = 1.7 \times 10^{-6} \text{ C} = 1.7 \mu\text{C}$

$$0.1 = \frac{9 \times 10^9 \times q^2}{(0.5)^2}$$

### Example 2.2

Two small charged spheres are placed 0.300 m apart. The first has a charge of  $-3.00 \mu\text{C}$  (micro-Coulombs), and the second has a charge of  $-12.0 \mu\text{C}$ . Do these charged spheres attract or repel? What is the magnitude of the electrostatic force on each sphere?

**Answer:** The spheres have charges with the same sign, and so the force between them is repulsive. The direction of the force on each sphere points away from the other. To find the magnitude of the force, the charge on the particles must be converted to Coulombs. The prefix " $\mu$ ", meaning "micro", indicates that the number is scaled by  $10^{-6}$ , and so  $1 \mu\text{C} = 10^{-6} \text{ C}$ . The charge of the first sphere is:

$$q_1 = -3.00 \mu\text{C}$$

$$q_1 = -3.00 \times 10^{-6} \text{ C}$$

**The charge of the second sphere is:**

$$q_2 = -12.0 \mu\text{C}$$

$$q_2 = -1.20 \times 10^{-5} \text{ C}$$

**The magnitude of the electrostatic force on each sphere can be found using Coulomb's Law:**

$$F = k \frac{|q_1 q_2|}{r^2}$$

$$F = (8.988 \times 10^9 \text{ N} \cdot \text{m}^2 / \text{C}^2) \frac{|(-3.00 \times 10^{-6} \text{ C})(-1.20 \times 10^{-5} \text{ C})|}{(0.300 \text{ m})^2}$$

$$F = (8.988 \times 10^9 \text{ N} \cdot \text{m}^2 / \text{C}^2) \frac{|(-3.00 \times 10^{-6} \text{ C})(-1.20 \times 10^{-5} \text{ C})|}{0.0900 \text{ m}^2}$$

$$F = (8.988 \times 10^9 \text{ N} \cdot \text{m}^2 / \text{C}^2) \frac{3.60 \times 10^{-11} \text{ C}^2}{9.00 \times 10^{-2} \text{ m}^2}$$

$$F = \left( 8.988 \times 10^9 \text{ N} \cdot \frac{\text{m}^2}{\text{C}^2} \right) \left( 0.400 \times 10^{-11+2} \frac{\text{C}^2}{\text{m}^2} \right)$$

$$F = \left( 8.988 \times 10^9 \text{ N} \cdot \frac{\text{m}^2}{\text{C}^2} \right) \left( 0.400 \times 10^{-9} \frac{\text{C}^2}{\text{m}^2} \right)$$

$$F = (8.988 \times 10^9 \text{ N})(0.400 \times 10^{-9})$$

$$F \cong 3.595 \times 10^0 \text{ N} \quad F \cong 3.595 \text{ N}$$

**The magnitude of the force on each sphere is 3.595 N (Newtons).**

### Example 2.3

**An electron and a proton are 1.000 nm (nanometer) from each other. The charge of an**

electron is  $q_e = -1.602 \times 10^{-19} \text{ C} = -e$ , and the charge of a proton is  $q_p = +1.602 \times 10^{-19} \text{ C} = +e$ . Do these charges attract or repel? What is the magnitude of the electrostatic force on these charged particles?  
**Answer:** The electron and proton have charges with opposite signs, and so the force between them is attractive. The direction of the force on each particle is in the direction of the other. To find the magnitude of the force, the distance between the particles must first be converted to meters. The prefix "n", meaning "nano", indicates that the number is scaled by  $10^{-9}$ , and so  $1 \text{ nm} = 10^{-9} \text{ m}$ . The distance between the charged particles is:

$$r = 1.000 \text{ nm} \qquad r = 1.000 \times 10^{-9} \text{ m}$$

The magnitude of the electrostatic force between the particles can be found using Coulomb's Law:

$$F = k \frac{|q_1 q_2|}{r^2}$$

$$F = (8.988 \times 10^9 \text{ N} \cdot \text{m}^2 / \text{C}^2) \frac{|(-e)(+e)|}{(1.000 \times 10^{-9} \text{ m})^2}$$

$$F = (8.988 \times 10^9 \text{ N} \cdot \text{m}^2 / \text{C}^2) \frac{e^2}{1.000 \times 10^{-18} \text{ m}^2}$$

$$F = (8.988 \times 10^9 \text{ N} \cdot \text{m}^2 / \text{C}^2) \frac{(1.602 \times 10^{-19} \text{ C})^2}{1.000 \times 10^{-18} \text{ m}^2}$$

$$F \cong \left( 8.988 \times 10^9 \text{ N} \cdot \frac{\text{m}^2}{\text{C}^2} \right) \left( 2.5664 \times 10^{-38+18} \frac{\text{C}^2}{\text{m}^2} \right)$$

$$F \cong \left( 8.988 \times 10^9 \text{ N} \cdot \frac{\text{m}^2}{\text{C}^2} \right) \left( 2.5664 \times 10^{-20} \frac{\text{C}^2}{\text{m}^2} \right)$$

$$F \cong (8.988 \times 10^9 \text{ N})(2.5664 \times 10^{-20})$$

$$F \cong 23.07 \times 10^{-11} \text{ N} \qquad F \cong 2.307 \times 10^{-10} \text{ N}$$

## 2.2.2 Electric force between more than two electric charges

### Electrostatic force between three linear point charges

**Example 2.4** A particle of charge  $q_1 = +6.0 \mu\text{C}$  is located on the  $x$ -axis at coordinate  $X_1 = 5.1 \text{ cm}$ . A second particle of charge  $q_2 = -5.0 \mu\text{C}$  is placed on the  $x$ -axis at  $X_2 = -3.4 \text{ cm}$ . What is the magnitude and direction of the total electrostatic force acting on a third particle of charge  $q_3 = +2.0 \mu\text{C}$  placed at the origin ( $x = 0$ )?

**Solution:** The force  $F$  acting between charges 1 and 3 is given by

$$f = k_e \frac{q_1 q_3}{x_1^2} = (8.988 \times 10^9) \frac{(6 \times 10^{-6})(2 \times 10^{-6})}{(5.1 \times 10^{-2})^2} = +41.68 \text{ N.}$$

Since  $F > 0$ , the force is repulsive. This means that the force  $F_{13}$  exerted by charge 1 on charge 3 is directed along the  $-X$ -axis (*i.e.*, from charge 1 towards charge 3), and is of magnitude  $F_{13} = 41.69 \text{ N}$ . Thus,  $F_{13} = -41.69 \text{ N}$ . Here, we adopt the convention that forces directed along the  $+X$ -axis are positive, and *vice versa*.

The force  $F'$  acting between charges 2 and 3 is given by

$$f' = k_e \frac{q_2 q_3}{|x_2|^2} = (8.988 \times 10^9) \frac{(-5 \times 10^{-6})(2 \times 10^{-6})}{(3.4 \times 10^{-2})^2} = -77.75 \text{ N}$$

Since  $F < 0$ , the force is attractive. This means that the force  $F_{23}$  exerted by charge 2 on charge 3 is directed along the  $-X$ -axis (*i.e.*, from charge 3 towards charge 2), and is of magnitude  $F_{23} = 77.75 \text{ N}$ . Thus,  $F_{23} = -77.75 \text{ N}$ .

The resultant force  $F_3$  acting on charge 3 is the algebraic sum of the forces exerted by charges 1 and 2 separately (the sum is algebraic because all the forces act along the  $x$ -axis). It follows that

$$f_3 = f_{13} + f_{23} = -41.69 - 77.75 = -119.22 \text{ N. } f_3 < 0$$

Thus, the magnitude of the total force acting on charge 3 is 119.22N, and the force is directed along the  $-X$ -axis (since  $F_3 < 0$  ).

### Electrostatic force between three non-linear point charges

In the case of dealing with more than two charges. The total electric forces (The resultant electric forces) affecting the charge  $q_1$  as in figure 2.3, this force is  $F_1$ , which is the directional combination of all the forces exchanged with the charge  $q_1$  ie

$$\vec{F}_1 = \vec{F}_{12} + \vec{F}_{13} + \vec{F}_{14} + \vec{F}_{15}$$

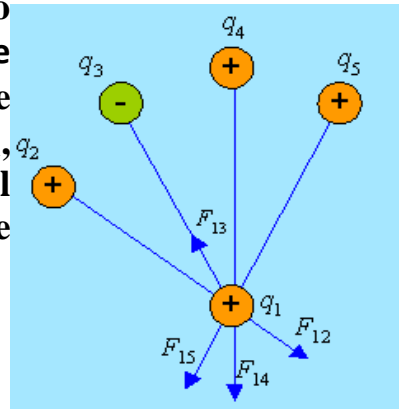

To calculate the value and direction of  $F_1$ , follow these steps :

- 1) We take  $q_1$  &  $q_2$  first, since the charges are positive. If  $q_1$  moves away from charge  $q_2$  along the line connecting them and the vector  $F_{12}$  is the direction of the force affecting the charge  $q_1$  the result of charge  $q_2$  and the length of the vector proportional to the amount of force. Similarly, we take packets  $q_1$  &  $q_3$ , determine the direction of force  $F_{13}$ , then determine  $F_{14}$ , and so on.
- 2) Here we ignore the electric forces exchanged between the charges  $q_2$  &  $q_3$  &  $q_4$  because we calculate the forces acting on  $q_1$ .
- 3) 4) To calculate the amount of force vectors each alone we make up the Coulomb's law as follows:



$$F_{12} = K \frac{q_1 q_2}{r^2}$$

$$F_{13} = K \frac{q_1 q_3}{r^2}$$

$$F_{14} = K \frac{q_1 q_4}{r^2}$$

4- The sum of these forces is  $F_1$ , but as shown in the figure, the forces line is different. Therefore, we use the vector analysis method for two compounds as follows

$$F_{1x} = F_{12x} + F_{13x} + F_{14x}$$

$$F_{1y} = F_{12y} + F_{13y} + F_{14y} \quad (\text{The resultant electric forces})$$

$$F_1 = \sqrt{(F_x)^2 + (F_y)^2}$$

$$\theta = \tan^{-1} \frac{F_y}{F_x}$$

**Example 2-5** Suppose that three point charges,  $q_a$ ,  $q_b$ , and  $q_c$ , are arranged at the vertices of a right-angled triangle, as shown in the diagram. What is the magnitude and direction of the electrostatic force acting on the third charge if,  $q_a = -6.0 \mu\text{C}$ ,  $q_b = +4.0 \mu\text{C}$ ,  $q_c = +2 \mu\text{C}$ ,  $a = 4.0\text{m}$ , and  $b = 3.0 \text{ m}$  ?

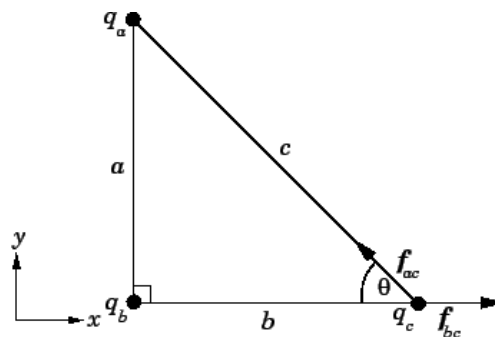

**Solution:** The magnitude  $F_{ac}$  of the force  $F_{ac}$  exerted by charge  $q_a$  on charge  $q_c$  is given by

$$f_{ac} = k_e \frac{|q_a|q_c}{c^2} = (8.988 \times 10^9) \frac{(6 \times 10^{-6})(2 \times 10^{-6})}{(4^2 + 3^2)} = 4.31 \times 10^{-3}$$

where use has been made of the Pythagorean theorem. The force is attractive (since charges  $q_a$  and  $q_c$  are of opposite sign).

Hence, the force is directed from charge  $q_c$  towards charge  $q_a$ , as shown in the diagram. The magnitude  $F_{bc}$  of the force  $F_{bc}$  exerted by charge  $q_b$  on charge  $q_c$  is given by

$$f_{bc} = k_e \frac{q_b q_c}{b^2} = (8.988 \times 10^9) \frac{(4 \times 10^{-6})(2 \times 10^{-6})}{(3^2)} = 7.99 \times 10^{-3}$$

The force is repulsive (since charges  $q_b$  and  $q_c$  are of the same sign). Hence, the force is directed from charge  $q_b$  towards charge  $q_c$ , as shown in the diagram. Now, the net force acting on charge  $q_c$  is the sum of  $F_{ac}$  and  $F_{bc}$ . Unfortunately, since  $F_{ac}$  and  $F_{bc}$  are vectors pointing in *different* directions, they *cannot* be added together algebraically. Fortunately, however, their components along the  $x$ - and  $y$ -axes *can* be added algebraically. Now, it is clear, from the diagram, that  $F_{bc}$  is directed along the  $+X$ -axis. It follows that

$$f_{bcx} = f_{bc} = 7.99 \times 10^{-3} \text{ N},$$

$$f_{bcy} = 0.$$

It is also clear, from the diagram, that  $F_{ac}$  subtends an angle

$$\theta = \tan^{-1}(a/b) = \tan^{-1}(4/3) = 53.1^\circ$$

with the  $-X$ -axis, and an angle  $90^\circ - \alpha$  with the  $+Y$ -axis. It follows from the conventional laws of vector projection that

$$f_{acx} = -f_{ac} \cos \theta = -(4.31 \times 10^{-3})(0.6) = -2.59 \times 10^{-3} \text{ N},$$

$$f_{acy} = f_{ac} \cos(90^\circ - \theta) = f_{ac} \sin \theta = (4.31 \times 10^{-3})(0.8) = 3.45$$

The  $x$  - and  $Y$  -components of the resultant force  $F_c$  acting on charge  $q_c$  are given by

$$f_{cx} = f_{acx} + f_{bcx} = -2.59 \times 10^{-3} + 7.99 \times 10^{-3} = 5.40 \times 10^{-3}$$

$$f_{cy} = f_{acy} + f_{bcy} = 3.45 \times 10^{-3} \text{ N.}$$

Thus, from the Pythagorean theorem, the magnitude of the resultant force is

$$f_c = \sqrt{(f_{cx})^2 + (f_{cy})^2} = 6.4 \times 10^{-3} \text{ N.}$$

Furthermore, the resultant force subtends an angle

$$\phi = \tan^{-1}(f_{cy}/f_{cx}) = 32.6^\circ$$

with the  $+X$  -axis, and an angle  $90^\circ - \phi = 57.4^\circ$  with the  $+y$  -axis.

**Example 2-6** what is the resultant force on the charge in the lower left corner of the square? Assume that  $q=1 \times 10^{-7} \text{ C}$  and  $a = 5 \text{ cm}$

**Solution** For simplicity we number the charges as shown in figure 2.5, then we determine the direction of the electric forces acted on the charge in the lower left corner of the square  $q_1$

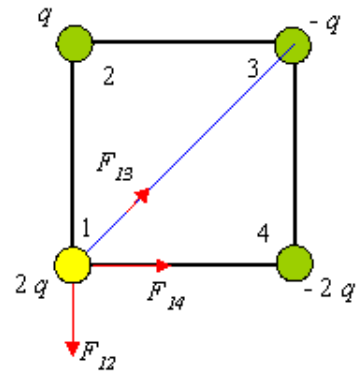

$$\vec{F}_1 = \vec{F}_{12} + \vec{F}_{13} + \vec{F}_{14}$$

$$F_{12} = K \frac{2qq}{a^2}$$

$$F_{13} = K \frac{2qq}{2a^2}$$

$$F_{14} = K \frac{2q2q}{a^2}$$

$$F_{12} = 0.072 \text{ N}, F_{13} = 0.036 \text{ N}, F_{14} = 0.144 \text{ N}$$

$$F_{13x} = F_{13} \sin 45 = 0.025 \text{ N} \quad \& \quad F_{13y} = F_{13} \cos 45 = 0.025 \text{ N}$$

$$F_x = F_{13x} + F_{14} = 0.025 + 0.144 = 0.169 \text{ N}$$

$$F_y = F_{13y} - F_{12} = 0.025 - 0.072 = -0.047 \text{ N}$$

The resultant force equals

$$F_1 = \sqrt{(F_x)^2 + (F_y)^2}$$

0.175 N =

The direction with respect to the x-axis equals

$$\theta = \tan^{-1} \frac{F_y}{F_x} = -15.5^\circ$$

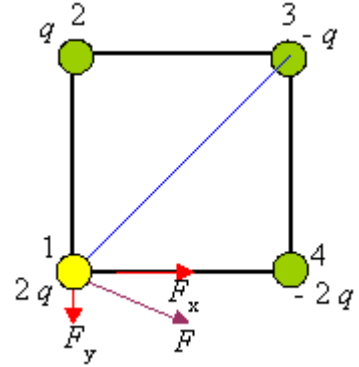

**Example 2.7** A charge  $Q$  is fixed at each of two opposite corners of a square as shown in figure 2.6. A charge  $q$  is placed at each of the other two corners. (a) If the resultant electrical force on  $Q$  is Zero, how are  $Q$  and  $q$  related. **Solution**

$$F_x = 0 \Rightarrow F_{12} - F_{13x} = 0$$

then  $F_{12} = F_{13} \cos 45$

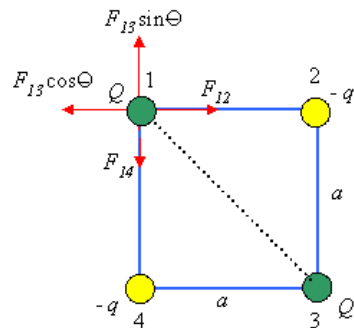

$$K \frac{Qq}{a^2} = K \frac{QQ}{2a^2 \sqrt{2}} \Rightarrow q = \frac{Q}{2\sqrt{2}}$$

$$F_x = 0 \Rightarrow F_{13y} - F_{14} = 0$$

$$F_{13} \sin 45 = F_{14}$$

$$K \frac{QQ}{2a^2 \sqrt{2}} = K \frac{Qq}{a^2} \Rightarrow q = \frac{Q}{2\sqrt{2}}$$

$$Q = 2\sqrt{2}q$$

$$Q = -2\sqrt{2}q$$

**Example 2.8** Two fixed charges,  $1\mu\text{C}$  and  $-3\mu\text{C}$  are separated by  $10\text{cm}$  as shown in figure 2.7 (a) where may a third charge be located so that no force acts on it? (b) is the equilibrium stable or unstable for the third charge?

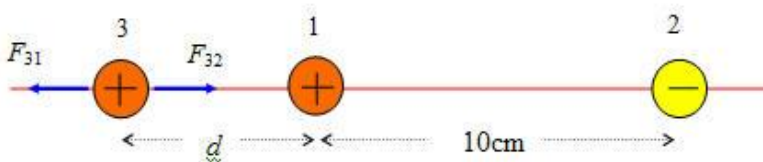

**Solution**

$$F_{31} = F_{32}$$

$$\frac{q_3}{1 \times 10 - e} = \frac{(q_1 + 10)q_3}{3 \times 10 - e}$$

$$q_3 \frac{1}{10 - e} = q_3 \frac{3}{30 - e}$$

(b) This equilibrium is unstable!! Why!!

**Example 2.9** Two charges are located on the positive x-axis of a coordinate system, as shown in figure 2.8. Charge  $q_1=2\text{nC}$  is  $2\text{cm}$  from the origin, and charge  $q_2=-3\text{nC}$  is  $4\text{cm}$  from the origin. What is the total force exerted by these two charges on a charge  $q_3=5\text{nC}$  located at the origin?

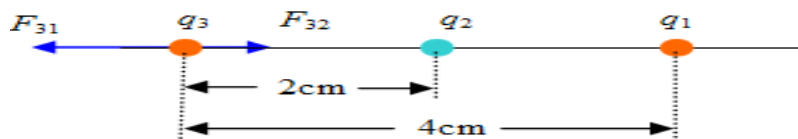

**Solution** The total force on  $q_3$  is the vector sum of the forces due to  $q_1$  and  $q_2$  individually.

$$F_{31} = \frac{(9 \times 10^9)(2 \times 10^{-9})(5 \times 10^{-9})}{(0.02)^2} = 2.25 \times 10^{-4} \text{ N}$$

$$F_{32} = \frac{(9 \times 10^9)(3 \times 10^{-9})(5 \times 10^{-9})}{(0.04)^2} = 0.84 \times 10^{-4} \text{ N}$$

$$F_3 = F_{31} + F_{32}$$

$$\therefore F_3 = 0.84 \times 10^{-4} - 2.25 \times 10^{-4} = -1.41 \times 10^{-4} \text{ N}$$

The total force is directed to the left, with magnitude  $1.41 \times 10^{-4} \text{ N}$ .

(problem)

(1) Two protons in a molecule are separated by a distance of  $3.8 \times 10^{-10} \text{ m}$ . Find the electrostatic force exerted by one proton on the other.

(2) A  $6.7 \mu\text{C}$  charge is located 5m from a  $-8.4 \mu\text{C}$  charge. Find the electrostatic force exerted by one on the other.

(3) Two fixed charges,  $+1.0 \times 10^{-6} \text{ C}$  and  $-3.0 \times 10^{-6} \text{ C}$ , are 10cm apart. (a) Where may a third charge be located so that no force acts on it? (b) Is the equilibrium of this third charge stable or unstable?

(4) Each of two small spheres is charged positively, the combined charge being  $5.0 \times 10^{-5} \text{ C}$ . If each sphere is repelled

from the other by a force of 1.0N when the spheres are 2.0m apart, how is the total charge distributed between the spheres?

(5) A certain charge  $Q$  is to be divided into two parts,  $q$  and  $Q-q$ . What is the relationship of  $Q$  to  $q$  if the two parts, placed a given distance apart, are to have a maximum Coulomb repulsion?

(6) A  $1.3\mu\text{C}$  charge is located on the  $x$ -axis at  $x=-0.5\text{m}$ ,  $3.2\mu\text{C}$  charge is located on the  $x$ -axis at  $x=1.5\text{m}$ , and  $2.5\mu\text{C}$  charge is located at the origin. Find the net force on the  $2.5\mu\text{C}$  charge.

(7) A point charge  $q_1 = -4.3\mu\text{C}$  is located on the  $y$ -axis at  $y=0.18\text{m}$ , a charge  $q_2 = 1.6\mu\text{C}$  is located at the origin, and a charge  $q_3 = 3.7\mu\text{C}$  is located on the  $x$ -axis at  $x = -0.18\text{m}$ . Find the resultant force on the charge  $q_1$ .

(8) Three point charges of  $2\mu\text{C}$ ,  $7\mu\text{C}$ , and  $-4\mu\text{C}$  are located at the corners of an equilateral triangle as shown in the figure 2.9. Calculate the net electric force on  $7\mu\text{C}$  charge. *Figure 2.9*

(9) Two free point charges  $+q$  and  $+4q$  are a distance 1cm apart. A third charge is so placed that the entire system is in equilibrium. Find the location, magnitude and sign of the third charge. Is the equilibrium stable?

(10) Four point charges are situated at the corners of a square of sides  $a$  as shown in the figure 2.10. Find the resultant force on the positive charge  $+q$ .

(11) Three point charges lie along the  $y$ -axis. A charge  $q_1 = -9\mu\text{C}$  is at  $y=6.0\text{m}$ , and a charge  $q_2 = -8\mu\text{C}$  is at  $y=-4.0\text{m}$ . Where must a third positive charge,  $q_3$ , be placed such that the resultant force on it is zero?

(12) A charge  $q_1$  of  $+3.4\mu\text{C}$  is located at  $x=+2\text{m}$ ,  $y=+2\text{m}$  and a second charge  $q_2=+2.7\mu\text{C}$  is located at  $x=-4\text{m}$ ,  $y=-4\text{m}$ . Where must a third charge ( $q_3>0$ ) be placed such that the resultant force on  $q_3$  will be zero?

(13) Two similar conducting balls of mass  $m$  are hung from silk threads of length  $l$  and carry similar charges  $q$  as shown in the figure 2.11. Assume that  $\theta$  is so small that  $\tan\theta$  can be replaced by  $\sin\theta$ . Show that

where  $x$  is the separation between the balls (b) If  $l=120\text{cm}$ ,  $m=10\text{g}$  and  $x=5\text{cm}$ , what is  $q$ ?



## Chapter (3)

### 3- 1 Electric field (المجال الكهربائي)

The Electric Field , Definition of the electric field ,The direction of E ,

Calculating E due to a charged particle and for a group of point charge ,Electric field lines , Motion of charge particles in a uniform electric field

, Solution of some selected problems , The electric dipole in electric field.

### 3 -2 Electric Flux

### الفيض الكهربائي

The Electric Flux due to an Electric Field, The Electric Flux due to a point charge, Gaussian surface, Gauss's Law, Gauss's law and Coulomb's law, Conductors in electrostatic equilibrium, Applications of Gauss's law.

### 3 -3 Electric Potential

### الجهد الكهربائي

Definition of electric potential difference, The Equipotential surfaces, Electric Potential and Electric Field, Potential difference due to a point charge, The potential due to a point charge, Electric Potential Energy, Calculation of E from V.

### 3-1-1 The Electric Field

The gravitational field  $g$  at a point in space was defined to be equal to the gravitational force  $F$  acting on a test mass  $m_o$  divided by the test mass

$$\vec{g} = \frac{\vec{F}}{m_o}$$

(3.1)

In the same manner, an *electric field* at a point in space can be defined in term of electric force acting on a test charge  $q_o$  placed at that point.

### 3-1-2 Definition of the electric field

The electric field vector  $E$  at a point in space is defined as ( the electric force  $F$  acting on a positive test charge placed at that point divided by the magnitude of the test charge  $q_o$



$$\vec{E} = \frac{\vec{F}}{q_o}$$

(3.2)

The electric field has a unit of N/C

**Point charge**: Any charge whether positive or negative, whose electric field is to be found at a particular distance(**point**) is called point charge.

**Test charge:** Any charge whose magnitude is very small, in fact negligible, as compared to that of the point charge, and which does not affect the electric field of the point charge, whose magnitude is to be found out, is called test charge.

### 3 -1-3 The direction of E

The direction of the electric field is always directed in the direction that a positive test charge would be pushed or pulled if placed in the space surrounding the source charge. Since electric field is a vector quantity, it can be represented by a vector arrow. For any given location, the arrows point in the direction of the electric field and their length is proportional to the strength of the electric field at that location.

If  $Q$  is +ve the electric field at point  $p$  in space is radially outward from  $Q$  as shown in figure 3.2(a).

If  $Q$  is -ve the electric field at point  $p$  in space is radially inward toward  $Q$  as shown in figure 3.2(b).

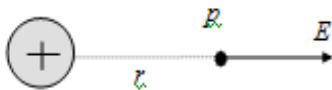

Figure 3.2 (a)

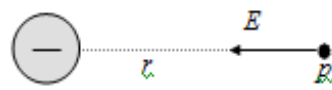

Figure 3.2 (b)

### 3-1-4 Calculating E due to a charged particle

Consider Fig. 3.2(a) above, the magnitude of force acting on  $q_0$  is given by Coulomb's law

$$\begin{aligned}
 F &= \frac{1}{4\pi\epsilon_0} \frac{Qq_0}{r^2} \\
 E &= \frac{F}{q_0} \\
 E &= \frac{1}{4\pi\epsilon_0} \frac{Q}{r^2}
 \end{aligned}$$

(3.3)

The [electric field](#) of a point charge can be obtained from [Coulomb's law](#):

$$E = \frac{F}{q} = \frac{kQ_{source}q}{qr^2} = \frac{kQ_{source}}{r^2}$$

The electric field is radially outward from the point charge in all directions. The circles represent spherical [equipotential surfaces](#). The electric field from any number of point charges can be obtained from a vector sum of the individual fields. A positive number is taken to be an outward field; the field of a negative charge is toward it. The direction of the **field** is taken to be the direction of the force it would exert on a positive test charge. **The electric field** is radially outward from a positive charge and radially in toward a negative point charge.

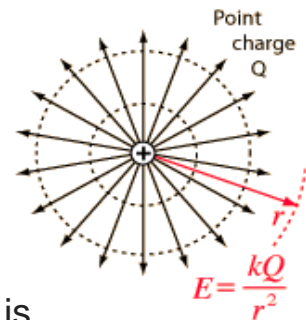

### 3-1-5 To find electric field for a group of point charges

To find the magnitude and direction of the electric field due to several charged particles as shown in figure use the following steps

$$E_p = E_1 + E_2 + E_3 + E_4 \dots\dots\dots (3.4)$$

$$E_x = E_{1x} + E_{2x} + E_{3x} + E_{4x}$$

$$E_y = E_{1y} + E_{2y} + E_{3y} + E_{4y}$$

$$E = \sqrt{E_x^2 + E_y^2}$$

$$\theta = \tan^{-1} \frac{E_y}{E_x}$$

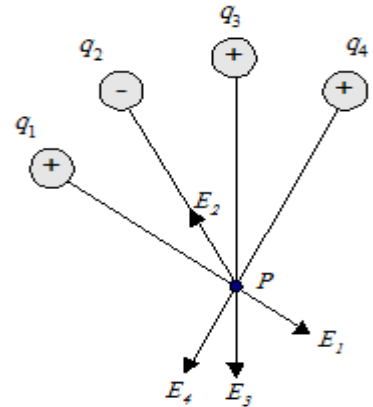

Figure 3.3

The electric field from multiple point charges can be obtained by taking

$$E_y = E_{1y} + E_{2y}$$

$$E_x = E_{1x} + E_{2x}$$

$$E = \sqrt{E_x^2 + E_y^2}$$

$$\tan \theta = \frac{E_y}{E_x}$$

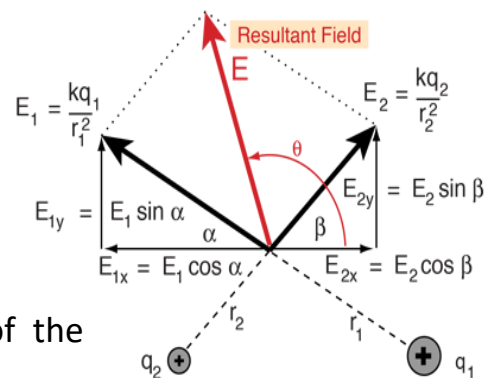

the vector sum of the electric fields of the individual charges.

After calculating the individual point charge fields, their components must be found and added to form the components of the resultant field. The resultant electric field can

then be put into [polar form](#). Care must be taken to establish the correct quadrant for the angle because of [ambiguities in the arctangent](#).

**3-1-6 Electric field lines** The electric lines are a convenient way to visualize the electric field patterns. The relation between the electric field lines and the electric field vector is this:

- (1) The tangent to a line of force at any point gives the direction of  $E$  at that point.
- (2) The lines of force are drawn so that the number of lines per unit cross-sectional area is proportional to the magnitude of  $E$ .
- (3) The lines must begin on positive charges and terminate on negative charges.
- (4) The number of lines drawn is proportional to the magnitude of the charge.
- (5) No two electric field lines can cross.

### Some examples of electric line of force

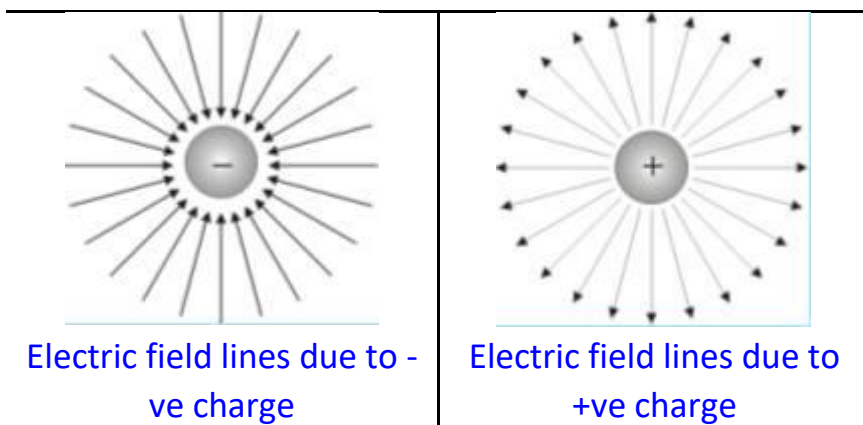



Electric field lines due two surface charge to +ve line      Electric field lines due to +ve line

Figure 3.7 shows some examples of electric line of force

### 3-1 -7 Motion of charge particles in a uniform electric field

If we are given a field  $E$ , what forces will act on a charge placed in it?

We start with special case of a point charge in uniform electric field  $E$ . The electric field will exert a force on a charged particle is given

$$\text{by } \mathbf{F} = q\mathbf{E}$$

The force will produce acceleration  $\mathbf{a} = \mathbf{F}/m$

where  $m$  is the mass of the particle. Then we can write

$$\mathbf{F} = q\mathbf{E} = m\mathbf{a}$$

The acceleration of the particle is therefore given by

$$\mathbf{a} = q\mathbf{E}/m \quad (3.7)$$

If the charge is positive, the acceleration will be in the direction of the electric field. If the charge is negative, the acceleration will be in the direction opposite the electric field.

### 3 -1- 8 Solution of some selected problems

**Example 3.1** Find the electric field at point  $p$  in figure 3.4 due to the charges shown.

**Solution**

$$\therefore \vec{E}_p = \vec{E}_1 + \vec{E}_2 + \vec{E}_3$$

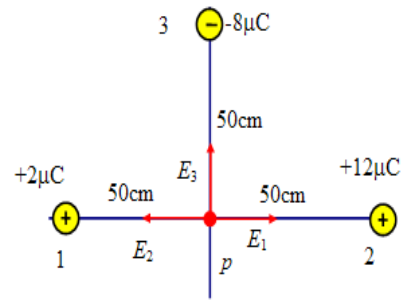

$$E_x = E_1 - E_2 = -36 \times 10^4 \text{ N/C}, \quad E_y = E_3 = 28.8 \times 10^4 \text{ N/C}$$

$$E_p = \sqrt{(36 \times 10^4)^2 + (28.8 \times 10^4)^2} = 46.1 \text{ N/C} \quad \theta = 141^\circ$$

Figure: Shows the resultant electric field

**Example 3.2** : Calculate at what distance from a negative charge of  $5.536 \text{ nC}$  would the electric field strength be equal to  $1.90 \times 10^5 \text{ N/C}$ ?

Solution:  $q = 5.536 \text{ nC}$ ,  $E = 1.90 \times 10^5 \text{ N/C}$ ,  $K = 9.0 \times 10^9 \text{ N} \cdot \text{m}^2 / \text{C}^2$

The symbols nC stand for nano

Coulombs. It is using the metric prefix “n”. We know that  $E = Kq / d^2$ . Substituting the values in the given formula we get,  $d = 1.6 \text{ cm}$ . Hence the electric field strength will be equal to  $1.90 \times$

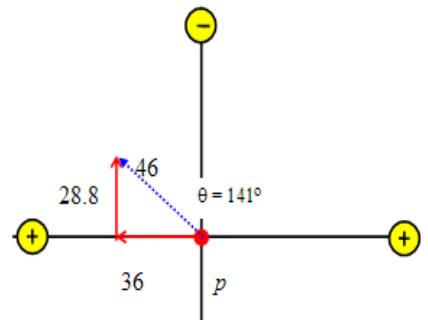



**Example 3.3:** What is the electric field in the lower left corner of the square as shown in figure 3.11? Assume that  $q = 1 \times 10^{-7} \text{C}$  and  $a = 5 \text{cm}$ .

**Solution :** First we assign number to the charges (1, 2, 3, 4) and then determine the direction of the electric field at the point  $p$  due to the charges.

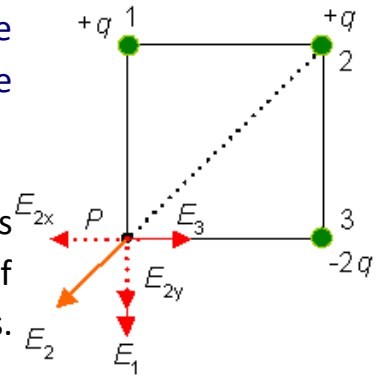

Figure 3.11

$$E_1 = \frac{1}{4\pi\epsilon_0} \frac{q}{a^2}$$

$$E_2 = \frac{1}{4\pi\epsilon_0} \frac{q}{2a^2}$$

$$E_3 = \frac{1}{4\pi\epsilon_0} \frac{2q}{a^2}$$

Evaluate the value of  $E_1$ ,  $E_2$ , &  $E_3$

$$E_1 = 3.6 \times 10^5 \text{ N/C},$$

$$E_2 = 1.8 \times 10^5 \text{ N/C},$$

$$E_3 = 7.2 \times 10^5 \text{ N/C}$$

Since the resultant electric field is the vector additions of all the fields *i.e.*

$$\vec{E}_p = \vec{E}_1 + \vec{E}_2 + \vec{E}_3$$

We find the vector  $E_2$  need analysis to two components

$$E_{2x} = E_2 \cos 45$$

$$E_{2y} = E_2 \sin 45$$

$$E_x = E_3 - E_2 \cos 45 = 7.2 \times 10^5 - 1.8 \times 10^5 \cos 45 = 6 \times 10^5 \text{ N/C}$$

$$E = \sqrt{E_x^2 + E_y^2} = 7.7 \times 10^5 \text{ N/C}$$

$$\theta = \tan^{-1} \frac{E_y}{E_x} = -38.6^\circ$$

## 3- 2 Electric Flux

### 3 -2-1 The Electric Flux due to an Electric Field

We have already shown how electric field can be described by lines of force. A line of force is an imaginary line drawn in such a way that its direction at any point is the same as the direction of the field at that point. Field lines never intersect, since only one line can pass through a single point.

**The Electric flux** ( $\Phi$ ) is a measure of the number of electric field lines penetrating some surface of area A.

#### Case one:

The electric flux for a plan surface perpendicular to a uniform electric field

To calculate the electric flux we recall that the number of lines per unit area is proportional to the magnitude of the electric field. Therefore, the number of lines penetrating the surface of area  $A$  is proportional to the product  $EA$ . The product of the electric field  $E$  and the surface area  $A$  perpendicular to the field is called the electric

flux  $\Phi$  .  $\Phi = EA$

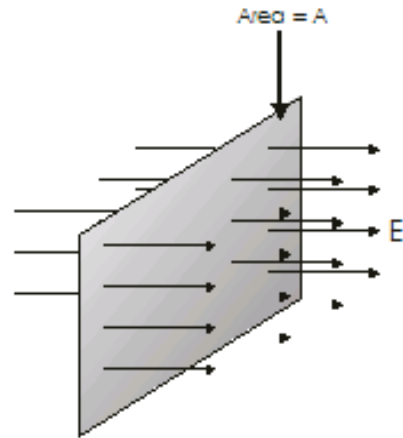

The electric flux  $\Phi$  has a unit of  $N.m^2/C$

### Case Two

The electric flux for a plan surface make an angle  $\theta$  to a uniform electric field : Note that the number of lines that cross-area is equal to the number that cross the projected area  $A'$ , which is perpendicular to the field. From the figure we see that the two area are related by  $A' = A \cos \theta$ . The flux is given by:

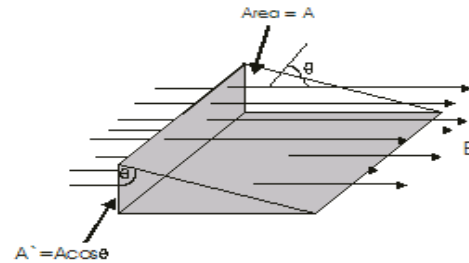

$$\Phi = EA'$$

$$\Phi = EA \cos \theta$$

Where  $\theta$  is the angle between the electric field  $E$  and the normal to the surface

### Case Three

In general the electric field is nonuniform over the surface

The flux is calculated by integrating the normal component of the field over the surface in question.

$$\Phi = \oint \vec{E} \cdot \vec{A}$$

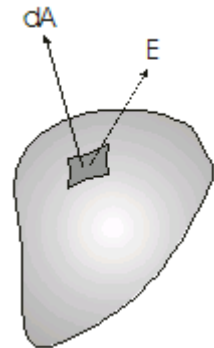

The **net flux** through the surface is proportional to the **net number of lines** penetrating the surface

### **3-2-2 Gaussian surface**

Consider several closed surfaces as shown in figure 4.6 surrounding a charge  $Q$  as in the figure below. The flux that passes through surfaces  $S_1$ ,  $S_2$  and  $S_3$  all has a value  $q/\epsilon_0$ . Therefore we conclude that the net flux through any closed surface is independent of the shape of the surface

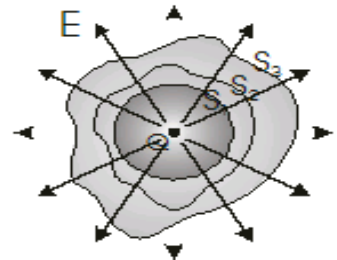

### 3-2 3 Gauss's Law

Gauss law is a very powerful theorem, which relates any charge distribution to the resulting electric field at any point in the vicinity of the charge. As we saw the electric field lines means that each charge  $q$  must have  $q/\epsilon_0$  flux lines coming from it. This is the basis for an important equation referred to as **Gauss's law**. Note the following facts:

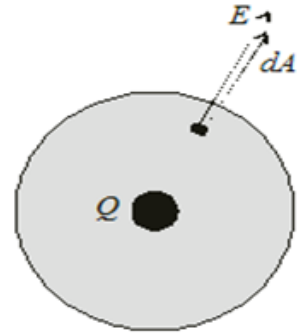

1. If there are charges  $q_1, q_2, q_3, \dots, q_n$  inside a closed (gaussian) surface, the total number of flux lines coming from these charges will be

$$(q_1 + q_2 + q_3 + \dots + q_n)/\epsilon_0 \quad (3.1)$$

2. The number of flux lines coming out of a closed surface is the integral of  $\vec{E} \cdot d\vec{A}$  over the surface,  $\oint \vec{E} \cdot d\vec{A}$ . We can equate both equations to get Gauss law which states that the net electric flux through a closed gaussian surface is equal to the net charge inside the surface divided by  $\epsilon_0$

$$\oint \vec{E} \cdot d\vec{A} = \frac{q_{in}}{\epsilon_0} \quad (3.2)$$

Gauss's law

where  $q_{in}$  is the total charge inside the gaussian surface.

Gauss's law states that ( the net electric flux through any closed gaussian surface is equal to the net electric charge inside the surface divided by the permittivity ).

**Example 3.4:** (a) Two charges of  $8\mu\text{C}$  and  $-5\mu\text{C}$  are inside a cube of sides  $0.45\text{m}$ . What is the total electric flux through the cube? (b) Repeat (a) if the same two charges are inside a spherical shell of radius  $0.45\text{m}$ .

**Solution :**  $\phi = q/\epsilon_0$

$$\phi = (+8 \times 10^{-6} - 5 \times 10^{-6}) / 8.85 \times 10^{-12} = 3.4 \times 10^5 \text{ N.m}^2/\text{C}$$

**Example 3.1:** A solid copper sphere  $15\text{cm}$  in radius has a total charge of  $40\text{nC}$ .

Find the electric field at the following distances measured from the center of the sphere:

(a)  $12\text{cm}$ , (b)  $17\text{cm}$ , (c)  $75\text{cm}$ . (d) How would your answers change if the sphere were hollow?

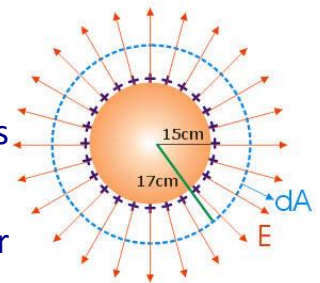

**Solution :** (a) At  $12\text{cm}$  the charge inside the gaussian surface is zero so the electric field  $E=0$  ,

**b**

$$\oint \vec{E} \cdot d\vec{A} = \frac{q_{in}}{\epsilon_0} \quad EA = \frac{q_{in}}{\epsilon_0}$$

$$E(4\pi r^2) = \frac{q_{in}}{\epsilon_0} \quad \therefore E = \frac{1}{4\pi\epsilon_0} \frac{q}{r^2}$$

$E = 125 \times 10^4 \text{ N/C}$  radially outward ,  $C- E = 639 \text{ N/C}$   
radially outward

### 3- 3Electric Potential

#### 3 -3-1 Definition of electric potential difference

We define the potential difference between two points A and B as( the work done by an external agent in moving a test charge  $q_0$  from A to B)

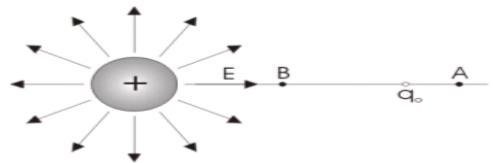

$$V_B - V_A = W_{AB} / q_0 \quad (3.3) \text{ i.e.}$$

The unit of the potential difference is (Joule/Coulomb) which is known as Volt

Since the work may be (a) positive i.e  $V_B > V_A$

(b) negative i.e  $V_B < V_A$  , (c) zero i.e  $V_B = V_A$

### 3-3-2 Electric Potential and Electric Field

#### 1- Simple Case (Uniform electric field):

The potential difference between two points A and B in a Uniform electric field E can be found as follow, Assume that a positive test charge  $q_0$  is moved by an external agent from A to B in uniform electric field as shown in figure. The test charge  $q_0$  is affected by electric force of  $q_0E$  in the downward direction. To move the charge from A to B an external force F of the same magnitude to the electric force but in the opposite direction. The

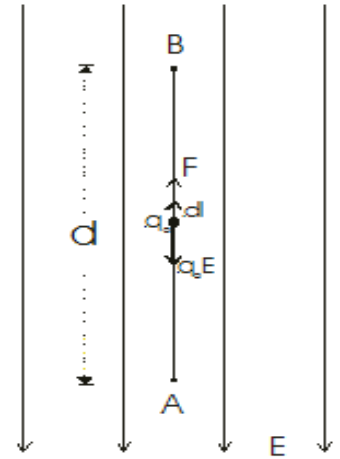

work  $W$  done by the external agent is:

$$W_{AB} = Fd = q_0Ed \quad (3.4)$$

The potential difference  $V_B - V_A$  is

$$V_B - V_A = \frac{W_{AB}}{q_0} = Ed \quad (3.5)$$

This equation shows the relation between the potential difference and the electric field for a special case (uniform electric field). Note

that E has a new unit (V/m). hence  $\frac{\text{Volt}}{\text{Meter}} = \frac{\text{Newton}}{\text{Coulomb}}$

#### 2 - The relation in general case (not uniform electric field):



If the test charge  $q_0$  is moved along a curved path from A to B as shown in figure. The electric field exerts a force  $q_0\mathbf{E}$  on the charge. To keep the charge moving without accelerating, an external agent must apply a force  $\mathbf{F}$  equal to  $-q_0\mathbf{E}$ . If the test charge moves distance  $d\mathbf{l}$  along the path from A to B, the work done is  $\mathbf{F}\cdot d\mathbf{l}$ . The total work is given by,

$$W_{AB} = \int_A^B \vec{F} \cdot d\vec{l} = -q_0 \int_A^B \vec{E} \cdot d\vec{l}$$

The potential difference  $V_B - V_A$  is,

$$V_B - V_A = \frac{W_{AB}}{q_0} = -\int_A^B \vec{E} \cdot d\vec{l}$$

If the point A is taken to infinity then  $V_A=0$  the potential  $V$  at point B is,

$$V_B = -\int_{\infty}^B \vec{E} \cdot d\vec{l}$$

This equation gives the general relation between the potential and the electric field.

### The Electron Volt Unit

A widely used unit of energy in atomic physics is the electron volt (eV). ELECTRON VOLT, unit of energy, used by physicists to express the energy of ions and subatomic particles that have been accelerated in particle accelerators. One electron volt is equal to the amount of energy gained by an electron traveling through an electrical potential difference of 1 V; this is equivalent to  $1.6 \times 10^{-19}$  J. Electron volts are commonly expressed as million electron volts (MeV) .

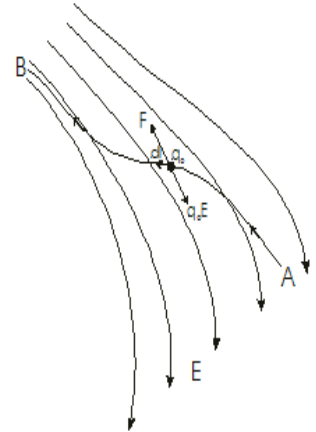

### 3 -3 -3 The potential due to a point charge

Assume two points A and B near to a positive charge  $q$  as shown in figure 5.7. To calculate the potential difference  $V_B - V_A$  we assume a test charge  $q_0$  is moved without acceleration from A to B in the figure above the electric field  $E$  is directed to the right and  $dl$  to the left

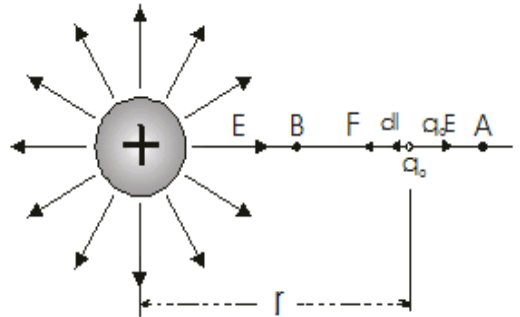

$$\vec{E} \cdot d\vec{l} = E \cos 180^\circ dl = -Edl$$

(3.6)

However when we move a distance  $dl$  to the left, we are moving in

a direction of decreasing  $r$   $d\vec{l} = -d\vec{r}$

Therefore ,  $-Edl = Edr$  (3.7)

$$\therefore V_B - V_A = -\int_A^B \vec{E} \cdot d\vec{l} = \int_{r_A}^{r_B} \vec{E} \cdot d\vec{r}$$

Substitute for E

$$\therefore E = \frac{1}{4\pi\epsilon_0} \frac{q}{r^2}$$

We get

$$\therefore V_B - V_A = -\frac{q}{4\pi\epsilon_0} \int_{r_A}^{r_B} \frac{dr}{r^2} = \frac{q}{4\pi\epsilon_0} \left( \frac{1}{r_B} - \frac{1}{r_A} \right)$$

If we choose A at infinity then  $V_A=0$  this lead to the potential at distance r from a charge q is given by

$$V = \frac{1}{4\pi\epsilon_0} \frac{q}{r} \qquad V = \frac{1}{4\pi\epsilon_0} \frac{q}{r}$$

If  $V = V_1 + V_2 + V_3 + \dots + V_n$

$$\therefore V = \sum_n V_n = \frac{1}{4\pi\epsilon_0} \sum_n \frac{q_n}{r_n}$$

Example3- 2: What must the magnitude of an isolated positive charge be for the electric potential at 10 cm from the charge to be +100V ?

$$V = \frac{1}{4\pi\epsilon_0} \frac{q}{r}$$

Solution

$$\therefore q = V4\pi\epsilon_0 r^2 = 100 \times 4\pi \times 8.9 \times 10^{-12} \times 0.1 = 1.1 \times 10^{-9} \text{ C}$$

### 3 – 3 -4 Calculation of E from V

As we have learned that both the electric field and the electric potential can be used to evaluate the electric effects. Also we have showed how to calculate the electric potential from the electric field now we determine the electric field from the electric potential

$$\vec{E} = -\frac{dV}{dl}$$

by the following relation.

New unit for the electric field is volt/meter (v/m)

**Example3 -3:** What is the potential at the center of the square shown in figure.? Assume that

$q_1 = +1 \times 10^{-8} \text{C}$ ,  $q_2 = -2 \times 10^{-8} \text{C}$ ,  $q_3 = +3 \times 10^{-8} \text{C}$ ,  $q_4 = +2 \times 10^{-8} \text{C}$ , and  $a = 1 \text{m}$ .

Solution

$$\therefore V = \sum_n V_n = \frac{1}{4\pi\epsilon_0} \frac{q_1 + q_2 + q_3 + q_4}{r}$$

The distance  $r$  for each charge from  $P$  is  $0.71 \text{m}$

$$\therefore V = \frac{9 \times 10^9 (1 - 2 + 3 + 2) \times 10^{-8}}{0.71} = 500 \text{V}$$

**Example3 -4:** Two charges of  $2 \mu\text{C}$  and  $-6 \mu\text{C}$  are located at positions

$(0,0) \text{ m}$  and  $(0,3) \text{ m}$ , respectively as shown in figure 5.13. (i) Find the total electric potential due to these charges at point  $(4,0) \text{ m}$ . (ii) How much work is required to bring a  $3 \mu\text{C}$  charge from  $\infty$  to the point  $P$

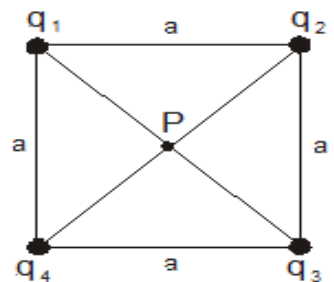

Figure 5.9

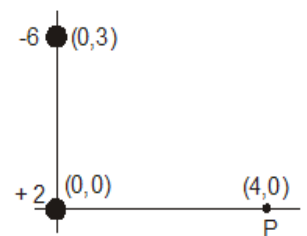

Figure 5.13

Solution

$$V_p = V_1 + V_2$$

$$V = \frac{1}{4\pi\epsilon_0} \left[ \frac{q_1}{r_1} + \frac{q_2}{r_2} \right]$$

$$V = 9 \times 10^9 \left[ \frac{2 \times 10^{-6}}{4} - \frac{6 \times 10^{-6}}{5} \right] = -6.3 \times 10^3 \text{ volt}$$

(ii) the work required is given by

$$W = q_3 V_p = 3 \times 10^{-6} \times -6.3 \times 10^3 = -18.9 \times 10^{-3} \text{ J}$$

The -ve sign means that work is done by the charge for the movement from  $\infty$  to  $P$ .

## Chapter (4)

# Capacitors and Capacitance

### 4 -1 Capacitor

### 4 -2 Definition of capacitance

### 4 – 3 Calculation of capacitance

Parallel plate capacitor

Cylindrical capacitor

Spherical capacitor

### 4 – 4 Combination of capacitors

Capacitors in parallel

Capacitors in series

### 4.5 Energy stored in a charged capacitor (in electric field)

### 4 . 6 Capacitor with dielectric

problems

## 4-1 Capacitor

A capacitor consists of two conductors separated by an insulator Figure (4.1.) The capacitance of the capacitor depends on the geometry of the conductors and on the material separating the charged conductors, called dielectric that is an insulating material. The two conductors carry equal and opposite charge  $+q$  and  $-q$ .

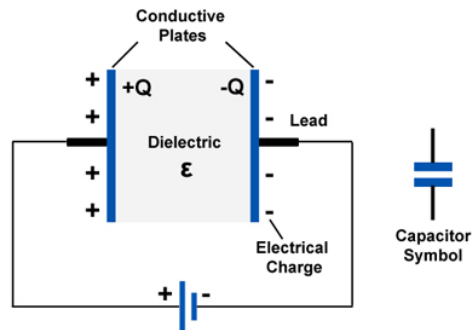

## 4-2 Definition of capacitance

The capacitance  $C$  of a capacitor is defined as the ratio of the magnitude of the charge on either conductor to the magnitude of the potential difference between them as shown in Figure

$$C = \frac{q}{V}$$

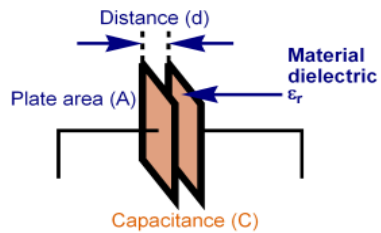

## 4.1

The capacitance  $C$  has a unit of  $C/v$ , which is called farad  
F

$$F = C/v$$

The farad is very big unit and hence we use submultiples of farad

$$1\mu\text{F} = 10^{-6} \text{ F}$$

$$1\text{nF} = 10^{-9} \text{ F}$$

$$1\text{pF} = 10^{-12}\text{F}$$

The capacitor in the circuit is represented by the symbol shown in Figure 4.3.

### 4-3 Calculation of capacitance

The most common type of capacitors are:-

- 1- Parallel-plate capacitor
- 2- Cylindrical capacitor
- 3 - Spherical capacitor

We are going to calculate the capacitance of parallel plate capacitor using the information we learned in the previous chapters and make use of the equation (4.1).

#### 1- Parallel plate capacitor

Two parallel plates of equal area  $A$  are separated by distance  $d$  as shown in figure (4.4 ). One plate charged with  $+q$ , the other  $-q$ . The capacitance is given by  $C = \frac{q}{V}$

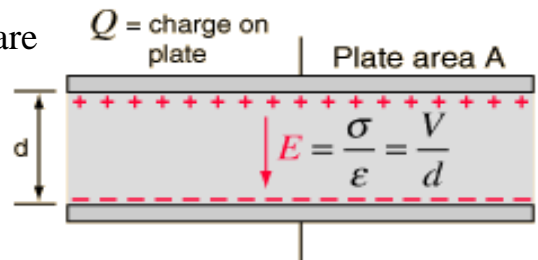

First we need to evaluate the electric field  $E$  to work out the potential  $V$ . Using gaus law to find  $E$ , the charge per unit area on either plate is

$$\sigma = \frac{q}{A} \quad \therefore E = \frac{\sigma}{\epsilon_0}$$

$$E = \frac{q}{\epsilon_0 A}$$



The potential difference between the plates is equal to  $Ed$ , therefore

$$V = Ed = \frac{qd}{\epsilon_0 A}$$

The capacitance is given by  $C = \frac{q}{V} = \frac{q}{qd/\epsilon_0 A}$

$$\therefore C = \frac{\epsilon_0 A}{d} \quad (4.2)$$

Notice that the capacitance of the parallel plates capacitor is depends on the geometrical dimensions of the capacitor. The capacitance is proportional to the area of the plates and inversely proportional to distance between the plates.

### **2- Cylindrical capacitor**

In the same way we can calculate the capacitance of cylindrical capacitor, the result is as follow

$$C = \frac{2\pi\epsilon_0 l}{\text{Ln}(b/a)}$$

( 4.3 )

Where  $l$  is the length of the cylinder,  $a$  is the radius of the inside cylinder, and  $b$  the radius of the outer shell cylinder.

### **3- Spherical Capacitor**

In the same way we can calculate the capacitance of spherical capacitor, the result is as follow

$$C = \frac{4\pi\epsilon_0 ab}{b - a}$$

( 4. 4 )

Where  $a$  is the radius of the inside sphere, and  $b$  is the radius of the outer shell sphere.

**Example 4-1** An air-filled capacitor consists of two plates, each with an area of  $7.6\text{cm}^2$ , separated by a distance of  $1.8\text{mm}$ . If a  $20\text{V}$  potential difference is applied to these plates, calculate, (a) the electric field between the plates,

(b) the surface charge density, (c) the capacitance, and (d) the charge on each plate.

**Solution** (a)  $E = \frac{V}{d} = \frac{20}{1.8 \times 10^{-3}} = 1.11 \times 10^4 \text{ V/m}$

(b)  $\sigma = \epsilon_0 E = (8.85 \times 10^{-12}) (1.11 \times 10^4) = 9.83 \times 10^{-8} \text{ C/m}^2$

(c)  $C = \frac{\epsilon_0 A}{d} = \frac{(8.85 \times 10^{-12})(7.6 \times 10^{-4})}{1.8 \times 10^{-3}} = 3.74 \times 10^{-12} \text{ F}$

(d)  $q = CV = (3.74 \times 10^{-12}) (20) = 7.48 \times 10^{-11} \text{ C}$

**Example 4-2** An air-filled spherical capacitor is constructed with inner and outer shell radii of  $7$  and  $14\text{cm}$ , respectively. Calculate, (a) The capacitance of the device, (b) What potential difference between the spheres will result in a charge of  $4\mu\text{C}$  on each

conductor? **Solution** : ( a )

$$C = \frac{4\pi\epsilon_0 ab}{b-a} = \frac{(4\pi \times 8.85 \times 10^{-12})(0.07)(0.14)}{(0.14-0.07)} = 1.56 \times 10^{-11} F$$

$$(b) V = \frac{q}{C} = \frac{4 \times 10^{-6}}{1.56 \times 10^{-11}} = 2.56 \times 10^5 V$$

#### 4-4 Combination of capacitors

Sometimes the electric circuit consist of more than two capacitors, which are, connected either in parallel or in series the equivalent capacitance is evaluated as follow

##### Capacitors in parallel:

In parallel connection the capacitors are connected as shown in figure 4.5 below where the above plates are connected together with the positive terminal of the battery, and the bottom plates are connected to the negative terminal of the battery.

In this case the potential different across each capacitor is equal to the voltage of the battery  $V$

$$\text{i.e. } V = V_1 = V_2 = V_3$$

The charge on each capacitor is

$$q_1 = C_1 V_1 \quad , \quad q_2 = C_2 V_2 \quad , \quad q_3 = C_3 V_3$$

The total charge is  $q = q_1 + q_2 + q_3$  (4-5)

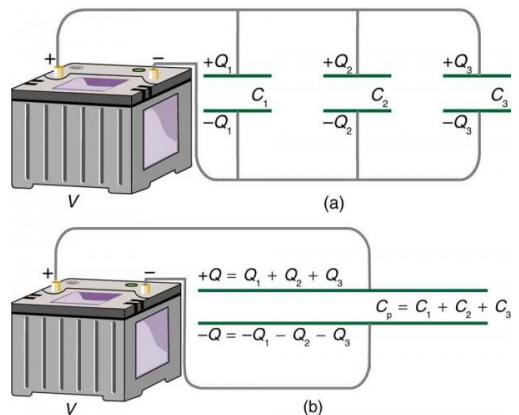

$$CV = (C_1 + C_2 + C_3) V$$

The Equivalent capacitance is

$$C = C_1 + C_2 + C_3$$

(4.6)

### Capacitors in series

In series connection the capacitors are connected as shown in figure 6.6 below where the above plates are connected together with the positive. In this case the magnitude of the charge must be the same on each plate with opposite sign i.e.

$$q = q_1 = q_2 = q_3$$

The potential across each capacitor is

$$V_1 = \frac{q}{C_1}, \quad V_2 = \frac{q}{C_2},$$

$$V_3 = \frac{q}{C_3}$$

The total potential  $V$  is equal the sum of the potential across each capacitor

$$V = V_1 + V_2 + V_3,$$

$$\frac{q}{C} = \frac{q}{C_1} + \frac{q}{C_2} + \frac{q}{C_3}$$

The Equivalent capacitance is

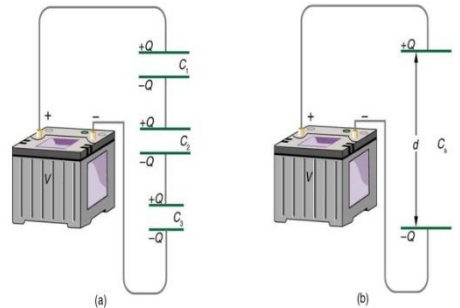
$$\frac{1}{C} = \frac{1}{C_1} + \frac{1}{C_2} + \frac{1}{C_3} \quad (4.7)$$

**Example 4-3** Find the total capacitance for three capacitors connected in series, given their individual capacitances are 1.000, 5.000, and 8.000  $\mu\text{F}$ .

**Solution** : the total capacitance can be found using the equation for capacitance in series  $\frac{1}{C} = \frac{1}{C_1} + \frac{1}{C_2} + \frac{1}{C_3}$   $C = 0.755 \mu\text{F}$

**Example 4-4** if the capacitors in Example (4-3) were connected in parallel, Find the total capacitance for three capacitors

**Solution** :  $C_p = 1.000 \mu\text{F} + 5.000 \mu\text{F} + 8.000 \mu\text{F} = 14.000 \mu\text{F}$ .

#### 4- 5 Energy stored in a charged capacitor (in electric field)

If the capacitor is connected to a power supply such as battery, charge will be transferred from the battery to the plates of the capacitor. This is a charging process of the capacitor which mean that the battery perform a work to store energy between the plates of the capacitor.

Consider uncharged capacitor is connected to a battery as shown in figure 6.8, at start the potential across the plates is zero and the charge is zero as well. If the switch  $S$  is closed then the charging process will start and the potential across the capacitor will rise to reach the value equal the potential of the battery  $V$  in time  $t$  (called charging time). at start the potential across the plates is zero and the charge is zero as well. Suppose that at a time  $t$  a charge  $q(t)$  has been transferred from the

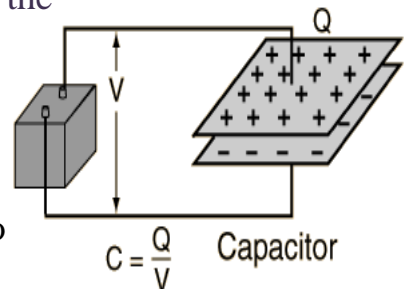

$$dw = Vdq = \frac{q}{C} dq$$

battery to capacitor. The potential difference  $V(t)$  across the capacitor will be  $q(t)/C$ . For the battery to transferred another amount of charge  $dq$  it will perform a work  $dW$

The total work required to put a total charge  $Q$  on the capacitor is

$$W = \int dW = \int_0^Q \frac{q dq}{C} = \frac{Q^2}{2C} \quad (4.9)$$

Using the equation  $q=CV$

$$W = U = \frac{Q^2}{2C} = \frac{1}{2} QV = \frac{1}{2} CV^2$$

**Example 4-4** Three capacitors of  $8\mu\text{F}$ ,  $10\mu\text{F}$  and  $14\mu\text{F}$  are connected to a battery of  $12\text{V}$ . How much energy does the battery supply if the capacitors are connected (a) in series and (b) in parallel?

**Solution :** For series combination  $\frac{1}{C} = \frac{1}{C_1} + \frac{1}{C_2} + \frac{1}{C_3}$  ,

This gives  $C = 3.37 \mu\text{F}$

Then the energy  $U$  is  $\frac{1}{2} CV^2$  ,

$$U = \frac{1}{2} (3.37 \times 10^{-6}) (12)^2 = 2.43 \times 10^{-4} \text{J}$$

For parallel combination  $C = C_1 + C_2 + C_3$

$$C = 8 + 10 + 14 = 32 \mu\text{F}$$

The energy  $U$  is  $U = \frac{1}{2} (32 \times 10^{-6}) (12)^2 = 2.3 \times 10^{-3} \text{J}$

## 4.6-Capacitor with dielectric

A dielectric is a non-conducting material, such as rubber, glass or paper. Experimentally it was found that the capacitance of a capacitor increased when a dielectric material was inserted in the

space between the plates. The ratio of the capacitance with the dielectric to that without it called the dielectric constant  $\kappa$  of the material

$$\mathbf{K} = C / C_0$$

### **Problems**

1 -Two capacitors,  $C_1=2\mu\text{F}$  and  $C_2=16\mu\text{F}$ , are connected in parallel. What is the value of the equivalent capacitance of the combination?

2-Calculate the equivalent capacitance of the two capacitors in the previous exercise if they are connected in series.

3-A  $100\text{pF}$  capacitor is charged to a potential difference of  $50\text{V}$ , the charging battery then being disconnected. The capacitor is then connected in parallel with a second (initially uncharged) capacitor. If the measured potential difference drops to  $35\text{V}$ , What is the capacitance of this second capacitor ?

4-A parallel-plate capacitor has circular plates of  $8.0\text{cm}$  radius and  $1.0\text{mm}$  separation. What charge will appear on the plates if a potential difference of  $100\text{V}$  is applied?

5-A  $6.0\mu\text{F}$  capacitor is connected in series with a  $4.0\mu\text{F}$  capacitor and a potential difference of  $200\text{V}$  is applied across the pair. (a) What is the charge on each capacitor?  
(b) What is the potential difference across each capacitor?

## Chapter ( 5)

# Current and Resistance

**5-1 - Electric Current**

**5-2- Ohm's Law :**

**5- 3 -Resistance and resistivity**

**5- 4 - Definition of the current density**

**5-5 -Definition of current in terms of the drift velocity**

**5- 6 Electric field inside a wire**

**5- 7 - Combination of Resistors**

**5- 7 .1- Resistors in Series**

**5- 7 -2- Resistors in Parallel**

**5- 7-3 - Physical facts for the series and parallel combination of resistors**

**5- 8 Electrical Energy and Power**



## 5 – 1 Electric Current :

**Electric Current** in a wire is defined as( the net amount of charge that passes through the wires full cross section at any point per unit time ) Thus ,the average current **I**

Is defined as  $I = \frac{\Delta Q}{\Delta t}$  where  $\Delta Q$  the amount of charge that passes through the conductor at any location during the time interval .

Current is a scalar quantity and has a unit of C / s , which is called **ampere**.

Thus ,1 ampere = 1 coulomb per second or  $1A = \frac{1C}{s}$

( where 1 coulomb =  $6.24 \times 10^{18}$  electrons )

**Example 1 :** what current must flow if 0.24 coulomb is to be transferred in 15 ms ?

Solution :since  $I = \frac{Q}{s} = \frac{0.24}{15 \times 10^{-3}} = \frac{0.24 \times 10^3}{15} = 16 A$

**Example 2 :** If a current of 10 A flows for four minutes , find the quantity of electricity transferred .

Solution : quantity of electricity ,

$$Q = It = 10 \times 4 \times 60 = 2400 C$$

**Example 3 :** A steady current of 2.5 A exists in a wire for 4.0 min . a – how much total charge passed by a given point in the circuit during those 4.min ? b – how many electrons would this be ?

Solution :  $Q = It = 2.5 \times 240 = 600 C$

b - the charge on one electron  $1.6 \times 10^{-19} C$

$$\frac{600}{1.6 \times 10^{-19}} = 3.8 \times 10^{21} \text{ electrons.}$$

## 4-2 Ohm's Law :

**Ohm's Law** states that the current  $I$  flow in a circuit is directly proportional to the applied voltage  $V$  and inversely proportional to the resistance  $R$ , provided the temperature remains constant. Thus ,

$$I = \frac{V}{R} \quad \text{or} \quad R = \frac{V}{I}$$

The resistance  $R$  of a conductor is defined as the ratio  $V/I$ , where  $V$  is the potential difference ( p.d.) across the conductor and  $I$  is the current flowing in it.

The unit of resistance is the ohm (  $\Omega$  ) 1 ohm is defined as the resistance which will have a current of 1 ampere flowing through it when 1 volt is connected across it ,i.e.

$$\text{resistance } R = \frac{\text{potential difference ( p.d.)}}{\text{current}}$$

$$(\Omega) = (V / A),$$

The resistance in the circuit is drawn using this symbol



**Fixed resistor**

مقاومة ثابتة



**Variable resistor**

مقاومة متغيرة



**Potential divider**

مجري للجهد الكهربائي



**Resistor Color Cods .**

Color	1st Band	2nd Band	3rd Band	4th Band
Black	0	0	1	1
Brown	1	1	10	
Red	2	2	100	
Orange	3	3	1,000	
Yellow	4	4	10,000	
Green	5	5	100,000	
Blue	6	6	1,000,000	
Violet	7	7	10,000,000	
Gray	8	8	100,000,000	
White	9	9	1,000,000,000	
Gold			0.1	5%
Silver			0.01	10%
None				20%

Example 4 : Find the current of an electrical circuit that has resistance of 50 Ohms and voltage supply of 5 Volts.

Solution:  $V = 5V$                        $R = 50\Omega$

$$I = V / R = 5V / 50\Omega = 0.1A = 100mA$$

Example 5 : Find the resistance of an electrical circuit that has voltage supply of 10 Volts and current of 5mA.

Solution:  $V = 10V$                        $I = 5mA = 0.005A$

$$R = V / I = 10V / 0.005A = 2000\Omega = 2k\Omega$$

Example 6 : A small flashlight bulb draws 300mA from its 1.5 V battery a – what is the resistance of the bulb . b – If the battery become weak and the voltage drops to 1.2 V . how would the current change ?

Solution: a -  $R = V / I = 1.5V / 0.3A = 5.0 \Omega$

b -  $I = V / R = 1.2 V / 5.0\Omega = 0.24 A = 240 Ma$

Example 7 : what is the resistance of a coil which draws a current of ( a ) 50 mA

And ( b ) 200  $\mu$  A from a 120 V supply ?

Solution: a  $R = V / I = 120V / 50 \times 10^{-3} A = 120 / 0.050 = 12000 / 5 = 2400 \Omega = 2.4 \text{ k } \Omega$

( b )  $R = \frac{V}{I} = \frac{120}{200 \times 10^{-6}} = 120 / 0.0002 = 600\,000 \Omega = 600 \text{ k } \Omega \text{ or } 0.6 \text{ M } \Omega$

### 4 – 3 Resistivity

It is found experimentally that the resistance  $R$  of an electrical conductor depends on 4 factors, these being :

- ( a ) length of the conductor .
- ( b ) the cross –sectional area of the conductor .
- ( c ) the type of material .
- ( d ) the temperature of the material .

Resistance  $R$ , is directly proportional to its length  $l$  . i.e  $R \propto l$ , and resistance  $R$  is inversely proportional to its cross –sectional area  $A$  of the conductor. i.e  $R \propto 1 / A$

where  $\rho$ , the constant of proportionality, is called the resistivity and depends on the material used .

The resistivity has unit of ohm meter ( $\Omega.m$ )

## Resistivity of various materials at 20°C

	Material	Resistivity ( $\Omega \cdot m$ )
1	Silver	$1.59 \times 10^{-8}$
2	Copper	$1.7 \times 10^{-8}$
3	Gold	$2.44 \times 10^{-8}$
4	Aluminum	$2.82 \times 10^{-8}$
5	Tungesten	$5.6 \times 10^{-8}$
6	Iron	$10 \times 10^{-8}$
7	Platinum	$11 \times 10^{-8}$
8	Lead	$20 \times 10^{-8}$
9	Nichrome	$150 \times 10^{-8}$
10	Carbon	$3.5 \times 10^{-5}$
11	Germanium	0.46
12	Silicon	640
13	Glass	$10^{10}-10^{14}$

Note that good conductor of electricity have a low resistivity and good insulator have a high value of resistivity.

The reciprocal of the resistivity, called the conductivity  $\sigma$

$$\sigma = \frac{1}{\rho} \quad \text{and has units of } (\Omega \cdot m)^{-1}$$

Notice that the resistance of a conductor depends on the geometry of the conductor, and the resistivity of the conductor depends only on the electronic structure of the material.

**Example 8:** A 0.90V potential difference is maintained across a 1.5m length of tungsten wire that has a cross-sectional area of  $0.60 \text{ mm}^2$ . What is the current in the wire?

**Solution:** From Ohm's law

$$I = \frac{V}{R} \quad \text{where } R = \rho \frac{\ell}{A}$$

therefore,

$$I = \frac{VA}{\rho \ell} = \frac{(0.90)(6.0 \times 10^{-7})}{(5.6 \times 10^{-8})(1.5)} = 6.43 A$$

**Example 9:** (a) Calculate the resistance per unit length of a 22 nichrome wire of radius 0.321mm. (b) If a potential difference of 10V is maintained cross a1m length of nichrome wire, what is the current in the wire.  $\rho_{nichromes} = 1.5 \times 10^{-6} \Omega \cdot m$ .

**Solution :**(a) The cross sectional area of the wire is

$$A = \pi r^2 = \pi (0.321 \times 10^{-3})^2 = 3.24 \times 10^{-7} m^2$$

The resistance per unit length is  $R/\ell$

$$\frac{R}{\ell} = \frac{\rho}{A} = \frac{1.5 \times 10^{-6}}{3.24 \times 10^{-7}} = 4.6 \Omega / m$$

(b) The current in the wire is

$$I = \frac{V}{R} = \frac{10}{4.6} = 2.2 A$$

*Nichrome wire is often used for heating elements in electric heater, toaster and irons, since its resistance is 100 times higher than the copper wire*

**Example 10 :** A 2.4m length of wire that is 0.031cm<sup>2</sup> in cross section has a measured resistance of 0.24  $\Omega$ .. Calculate the conductivity of the material

**Solution :**

$$R = \rho \frac{L}{A} \quad \text{and} \quad \rho = \frac{1}{\sigma} \quad \text{therefore}$$

$$\sigma = \frac{L}{RA} = \frac{2.4}{(0.24)(3.1 \times 10^{-6})} = 3.23 \times 10^6 / \Omega.m$$

**Example 11:** A 0.9V potential difference is maintained across a 1.5m length of tungsten wire that has cross-sectional area of  $0.6\text{mm}^2$ . What is the current in the wire?

**Solution:** From Ohm's law,

$$I = \frac{V}{R} \quad \text{where} \quad R = \rho \frac{L}{A} \quad \text{therefore}$$

$$I = \frac{VA}{\rho L} = \frac{0.9 \times 6 \times 10^{-7}}{5.6 \times 10^{-8} \times 1.5} = 6.43A$$

**Example 12 :** Determine the resistance of 1200m of copper cable having a diameter of 12mm if the resistivity of copper is  $1.7 \times 10^{-8} \Omega.m$

**Solution :** The cross sectional area of cable,  $a = \pi r^2 = \pi (12 / 2)^2 = 36 \pi \times 10^{-6} \text{m}^2$

$$R = \rho \frac{\ell}{A} = \frac{(1.7 \times 10^{-8})(1200)}{36\pi \times 10^{-6}} = \frac{1.7 \times 12}{36\pi} = 0.180\Omega$$

#### 4 – 4 -Definition of the current density

The electric current per unit cross-section area at any point in space is called the **current density** J.If the current density J in a wire of

cross-section area  $A$  is uniform over the cross-section, then  $J$  is related to the electric current by

$$\mathbf{J} = \frac{\mathbf{I}}{A} \quad \text{or}$$

$$I = J A$$

The current density is a vector quantity.

#### 4 -5 - Definition of current in terms of the drift velocity

Consider figure shown above. Suppose there are  $n$  positive charge particles per unit volume moves in the direction of the field from the left to the right, all move

with an average velocity called *drift velocity*  $v$ .

In time  $\Delta t$  each particle moves distance  $v\Delta t$  the shaded area in the figure, The volume of the shaded area in the figure is equal  $nAv\Delta t$ , the charge  $\Delta Q$  flowing across the end of the cylinder in time  $\Delta t$  is

$$\Delta Q = nqvA\Delta t \quad (4.1)$$

where  $q$  is the charge of each particle.

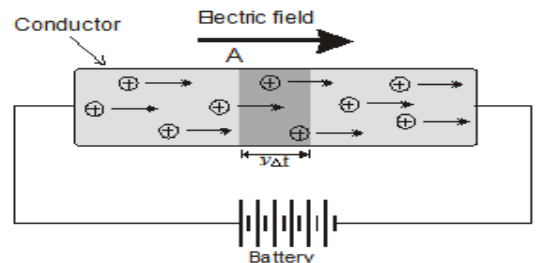



Then the current  $I$  is

$$I = \frac{\Delta Q}{\Delta t} = \frac{nq v A \Delta t}{\Delta t} = nq v A$$

(4. 2)

$$J = \frac{I}{A} = nq v$$

This drift velocity is very small compare with the velocity of propagation of current pulse, which is  $3 \times 10^8$  m/s. The smaller value of the drift velocity is due to the collisions with atoms in the conductor.

**Example 13 :** A copper conductor of square cross section  $1\text{mm}^2$  on a side carries a constant current of 20A. The density of free electrons is  $8 \times 10^{28}$  electron per cubic meter. Find the current density and the drift velocity.

**Solution :** The current density is  $J = \frac{I}{A} = 20 \times 10^6 \text{ A} / \text{m}^2$

The drift velocity is

$$v = \frac{J}{nq} = \frac{20 \times 10^6}{(8 \times 10^{28})(1.6 \times 10^{-19})} = 1.6 \times 10^{-3} \text{ m} \setminus \text{s}$$

#### 4 – 6 Electric field inside a wire

Equation  $V = I R$ , can be written the resistance  $R$  in terms of the resistivity :

$$R = \rho \frac{\ell}{A} \quad \text{and we write } V \text{ and } I \text{ as } I = J A \quad \text{and}$$

$$V = EL$$

We have 
$$El = (JA)\left(\rho \frac{\ell}{A}\right) = J\rho\ell$$

so 
$$J = \frac{1}{\rho} E = \sigma E$$

Where  $\sigma = 1/\rho$  is

### The **conductivity**

For metal conductor ,  $\rho$  and  $\sigma$  do not depend on  $V$  ( and hence not on  $E$  ). Therefore current density  $J$  is proportional to the electrical field  $E$  in the conductor .This is the ( microscopic ) statement of **Ohm's Law**

### 4 – 7 **Combination of Resistors**

Some times the electric circuit consist of more than two resistors, which are, connected either in parallel or in series the equivalent resistance is evaluated as follow:

#### 4- 7-1 Resistors in Series:

The figure shows three resistor in series, carrying a current  $I$ . **For a series connection of resistors, the current is the same in each resistor.** If  $V_{AD}$  is the potential difference across the whole resistors, the electric energy supplied to the system per second is  $IV_{AD}$ . This is equal to the electric energy dissipated per second in all the resistors.

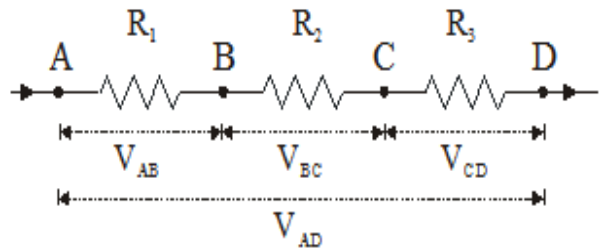

$$IV_{AD} = IV_{AB} + IV_{BC} + IV_{CD} \quad , \quad \text{Hence}$$

$$V_{AD} = V_{AB} + V_{BC} + V_{CD}$$

The individual potential differences are

$$V_{AB} = IR_1, \quad V_{BC} = IR_2 \quad , \quad V_{CD} = IR_3$$

Therefore

$$V_{AD} = IR_1 + IR_2 + IR_3 \quad ,$$

$$V_{AD} = I(R_1 + R_2 + R_3)$$

The equivalent resistor is

$$R = R_1 + R_2 + R_3$$

#### [4-7- 2 Resistors in Parallel:](#)

The figure shows three resistor in parallel, between the points A and B, A current  $I$  enter from point A and leave from point B, setting up a potential difference  $V$ .

For a parallel connection of resistors, the potential difference is equal **across each resistor**. The current branches into  $I_1, I_2, I_3$ , through the three resistors and,

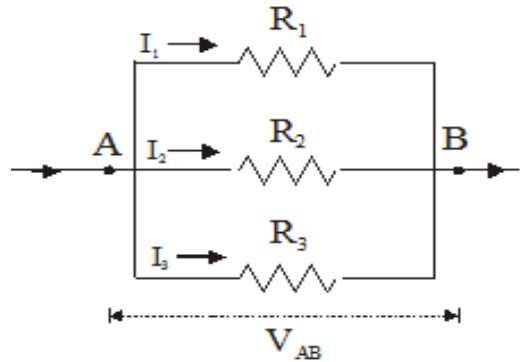

$$I = I_1 + I_2 + I_3$$

The current in each branch is given by

$$I_1 = \frac{V_{AB}}{R_1}, \quad I_2 = \frac{V_{AB}}{R_2}, \quad ,$$

$$I_3 = \frac{V_{AB}}{R_3}$$

$$I = \frac{V_{AB}}{R_1} + \frac{V_{AB}}{R_2} + \frac{V_{AB}}{R_3}$$

The equivalent resistance is

$$\frac{1}{R} = \frac{1}{R_1} + \frac{1}{R_2} + \frac{1}{R_3} \quad (4-4)$$

#### 4- 7-3 -Physical facts for the series and parallel combination of resistors

No.	Series combination	Parallel combination
1	Current is the same through all resistors	Potential difference is the same through all resistors
2	Total potential difference = sum of the individual potential difference	Total Current = sum of the individual current
3	Individual potential difference directly proportional to the individual resistance	Individual current inversely proportional to the individual resistance
4	Total resistance is greater than greatest individual resistance	Total resistance is less than least individual resistance

Notice that parallel resistors combine in the same way that series capacitors combine, and vice versa

**Example 14:** Two wires *A* and *B* of circular cross section are made of the same metal and have equal length, but the resistance of wire *A* is three times greater than that of wire *B*. What is the ratio of their cross-sectional area? How do their radii compare?

**Solution :** Since  $R = \rho L/A$ , the ratio of the resistance  $R_A/R_B = A_A/A_B$ . Hence, the ratio is three times. That is, the area of wire *A* is three times that of *B*. The radius of wire *a* is  $\sqrt{3}$  times the radius of wire *B*.

## 4 -8 Electrical Energy and Power

The current can flow in circuit when a battery is connected to

an electrical device through conducting wire as shown in

figure . If the positive terminal of the battery is connected to  $a$

and the negative terminal of the battery is connected to  $b$

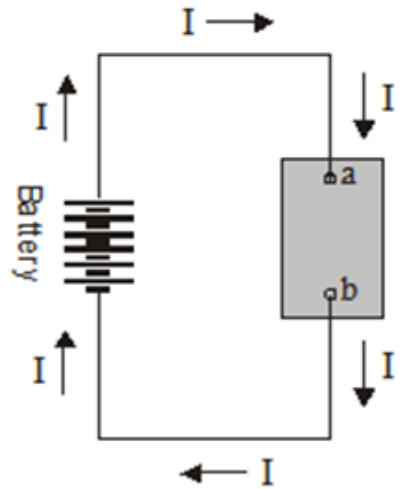

of the device. A charge  $dq$  moves through the device from

$a$  to  $b$ . The battery perform a work  $dW = dq V_{ab}$ .

This work is by the battery is energy  $dU$  transferred to the device in time  $dt$  therefore.

$$dU = dW = dq V_{ab} = I dt V_{ab}$$

The rate of electric energy ( $dU/dt$ ) is an electric power ( $P$ ).

$$P = \frac{dU}{dt} = I V_{ab}$$

Suppose a resistor replaces the electric device, the electric power is

$$P = I^2 R \quad , \quad P = \frac{V^2}{R}$$

The unit of power is (*Joule/sec*) which is known as *watt* ( $W$ ).

**Example 15 :** An electric heater is constructed by applying a potential difference of 110

volt to a nichrome wire of total resistance  $8\Omega$ . Find the current carried by the wire and

the power rating of the heater.

**Solution :** Since  $V = IR$       $I = \frac{V}{R} = \frac{110}{8} = 13.8A$

The power  $P$  is      $P = I^2R = (13.8)^2 \times 8 = 1520W$

**Example 16 :** A light bulb is rated at  $120v/75W$ . The bulb is powered by a  $120v$ . Find the current in the bulb and its resistance.

**Solution:**  $P = IV$       $I = \frac{V}{P} = \frac{75}{120} = .625A$

The resistance is      $R = \frac{V}{I} = \frac{120}{0.625} = 192\Omega$

**Example 16 :** Two conductors of the same length and radius are connected across the same potential difference. One conductor has twice the resistance of the other. Which conductor will dissipate more power?

**Solution :** Since the power dissipated is given by  $P=V^2/R$ , the conductor with the lower resistance will dissipate more power.

**Example 17 :** Two light bulbs both operate from  $110v$ , but one has power rating  $25W$  and the other of  $100W$ . Which bulb has the higher resistance? Which bulb carries the greater current?

**Solution :** Since  $P=V^2/R$ , and  $V$  is the same for each bulb, the  $25W$  bulb would have the higher resistance. Since  $P=IV$ , then the  $100W$  bulb carries the greater current

**Example 18 :** If a  $55\Omega$  resistor is rated at  $125W$ , what is the maximum allowed voltage?

**Solution :**  $P = \frac{V^2}{R}$  ,  $V = \sqrt{PR} = \sqrt{125 \times 55} = 82.9V$











