



اسم المقرر : رياضيات

استاذ المقرر : د. منتصر فكري عبد الظاهر

الفرقة : الاولي

الشعبة : فيزيائية



*South valley University*



*Faculty of science-Qena  
Mathematics Department*

# Statics: Lecture Notes

Prepared by

Department of Mathematics staff

# Contents

**Chapter: 1** Introduction

**Chapter: 2** Vectors Forces

**Chapter: 3** Condition for the Equilibrium of a particle

**Chapter: 4** Friction

**Chapter: 5** Center of Gravity, Center of Mass and Centroids

**Chapter: 6** Virtual Work

# Statics Notes

## Chapter: 1

### Introduction

#### General principles

**Mechanics:** Mechanics is a branch of physical sciences which describes or predicts the conditions of rest or motion of bodies under the action of forces.

**Mechanics:** Mechanics is a branch of physical sciences that is concerned with the state of rest or motion of bodies that are subjected to the action of forces.

Mechanics can be subdivided into three branches: rigid body mechanics- deformable body mechanics- fluid mechanics

1- Rigid bodies: (i) Statics (ii) Dynamics

2- Deformable bodies

3- Fluid Mechanics: (i) Compressible – gas (ii) incompressible - liquids

Here we will study only the rigid body Mechanics. In the first term we will study some subjects in Statics

In Statics we will assume the bodies to be perfectly rigid, no deformation.

This is never true in the real world, everything deforms a little when a load is applied.

These deformations are small and will not significantly affect the conditions of equilibrium or motion, so we will neglect the deformations.

#### Basic Quantities

**Basic Concepts:** There are four basic quantities in Mechanics space, time, mass, force:

(1) - Length: Length is used to locate the position of a point and describe the size of physical systems.

(2) - Time: Time is the measure of the succession of events and it is important in Dynamics

(3) - Mass: Mass is a measure of a quantity of matter that is used to compare the action of one body with that of another. This property manifests itself as a gravitational attraction between two bodies and provides a measure of the resistance of matter to a change in velocity.

(4) - Force: Force is push or pull exerted by one body on another. This interaction can occur when there is direct contact between the bodies, such as a person pushing on a wall, or it can occur through a distance when the bodies are physically separated.

**Idealizations:** Models or idealizations are used in mechanics in order to simplify application of the theory. Here we will consider three important idealizations.

(i) - **Particle:** A particle has a mass, but a size that can be neglected. For example, the size of the earth is insignificant compared to the size of its orbit, and therefore the earth can be modeled as a particle when studying its orbital motion.

(ii) - **Rigid Body:** A rigid body is a combination of a large number of particles in which all the particles remain at a fixed distance from one another, both before and after applying a load

A rigid body is considered rigid when the relative movement between its parts is negligible.

(iii) - **Concentrated Force.** A concentrated force represents the effect of a loading which is assumed to act at a point on a body when the contact area is small compared with the overall size. We can represent a load by a concentrated force, provided the area over which the load is applied is very small compared to the overall size of the body.

An example would be the contact force between a wheel and the ground

### Weight and Mass

Weight is the measure of how heavy an object

The unit of measurement for weight is that of force, which in the International System of Units (SI) is the newton.

Mass is both a property of a physical body and a measure of its resistance to acceleration (a change in its state of motion) when a net force is applied (The mass of an object is the amount of material it contains. ). An object's mass also determines the strength of its gravitational attraction to other bodies.

The unit of measurement for mass in the International System of Units (SI) is the kilogram (kg).

Weight is not the same thing as mass. Mass is a literal representation of the amount of matter in a particle or object, and is independent of external factors such as speed, acceleration, or applied force (as long as relativistic effects are small enough to be neglected). Weight has meaning only when an object having a specific mass is placed in

an acceleration field. At the Earth's surface, a kilogram mass weighs about 2.2 pounds, for example. But on Mars, the same kilogram mass would weigh only about 0.8 pounds

### Newton's Three Laws of motion:

Engineering Mechanics is formulated on the basis of Newton's three Laws of motion:

#### First Law (1<sup>st</sup> Law):

A particle originally at rest, or moving in a straight line with constant velocity, tends to remain in this state provided the particle is not subjected to an unbalanced force.

A particle remains at rest or continues to move in a straight line with a constant speed if there is no unbalanced force acting on it (resultant force = 0).

#### Second Law (2<sup>nd</sup> Law):

A particle acted upon by an unbalanced force ( $F$ ) experiences an acceleration ( $a$ ) that has the same direction as the force and a magnitude that is directly proportional to the force.

If ( $F$ ) is applied to a particle of mass ( $M$ ), this law may be expressed mathematically as

$$F = M a$$

#### Third Law (3<sup>rd</sup> Law):

For every action there is an equal and opposite reaction.

The mutual forces of action and reaction between two particles are equal, opposite, and collinear

The forces of action and reaction between interacting bodies are equal in magnitude, opposite in direction, and act along the same line of action (Collinear).

### Newton's Law of Gravitation Attraction

The gravitational attraction force between any two particles is

$$F = G \frac{M m}{r^2},$$

$F$  = mutual force of attraction between two particles

$G$  = universal constant known as the constant of gravitation

$M, m$  = masses of each of the two particles

$r$  = distance between the two particles

### What am I talking about? Weight.

The weight of a particle is the gravitational force between a particle and earth;

By using the equation  $g = \frac{GM}{r^2}$ , where

$M$  = mass of earth,  $m$  = mass of a particle

$r$  = radius of earth,  $g$  = acceleration of gravity at earth's surface

$$\text{Using } g = \frac{GM}{r^2} \rightarrow G = \frac{g r^2}{M}$$

Substituting into  $F = G \frac{M m}{r^2}$ , we have  $F = \frac{g r^2}{M} \left( \frac{M m}{r^2} \right)$

$$F = m g \Rightarrow \text{weight is } W = m g$$

Or using  $F = m a$  and at the surface of the Earth  $a = g$

$$\therefore F = m g, \text{ then } W = m g$$

$g$  is dependent upon  $r$ . Most cases use  $g = 9.81 \text{ m/s}^2 = 32.2 \text{ ft/s}^2$

## Units of Measurement

A unit of measurement is a definite magnitude of a physical quantity.

There are two main measurement systems:

(1)- Metric system (International system SI):

This system is based on three main units:

Meter – Kilogram – Second ( It is called mks System).

SI is an abbreviation of French expression (**S**ysteme **I**nternational d'Unités) in English (International system)

(2) – English system (British System or Imperial System or US Customary System)

This system is based on three main units:

Foot - Pound - Second (It is also called FPS system). See below Table

Name	Length	Time	Mass	Force
International system of Units (SI)	Meter	Second	Kilogram	Newton
	$m$	$s$	$kg$	$N = \frac{kg \cdot m}{s^2}$
U. S. Customary FPS	Foot	Second	Slug	Pound
	$ft$	$s$	$N = \frac{lb \cdot s^2}{ft}$	$lb$

Pound (lb) , unit of avoirdupois weight, equal to 16 ounces, 7,000 grains, or 0.45359237 kg,

## Newton

The newton is a unit to for measuring force equal to the force needed to move one kilogram of mass at a rate of one meter per second squared.

The newton is the SI derived unit for force in the metric system. Newtons can be abbreviated as  $N$ , for example 1 newton can be written as  $1 N$ .

Newtons can be expressed using the formula:  $(1) N = (1 \text{ kg}) (1 \text{ m/s}^2)$ .

### Pound-Force

Pound-force is a unit of force equal to the force needed to move one pound of mass at a rate of 32.174049. 32 foot per second squared.

The pound-force is a US customary and imperial unit of force. A pound-force is sometimes also referred to as a pound of force. Pound-force can be abbreviated as

$lbF$  or  $lb_F$ . For example, 1 pound-force can be written as  $1 lbF$  or  $1 lb_F$ .

Pound-force can be expressed using the formula:  $1 lb = 32.174049 lb \frac{ft}{s^2}$ .

### How to convert kilograms to pounds

1 kilogram = 2.2046226218488 pounds

1 pound = 0.45359237 kilograms

If the mass  
is 1 kilogram

$$9.8 \text{ newtons} = 1 \text{ kg} \times 9.8 \text{ m/s}^2$$

The weight of 1 kg  
is 9.8 newtons

Weight

Mass    Acceleration  
of gravity

$$9.8N = 2.2 \text{ lbs}$$

$$W = m \times g$$

$$32.2 \text{ pounds} = 1 \text{ slug} \times 32.2 \text{ ft/s}^2$$

The weight of 1 slug  
is 32.2 pounds

If the mass  
is 1 slug

$$32.2 \text{ lb} = 143 \text{ N}$$

### Force: Newton (N)

$$(1) N = (1 \text{ kg}) (1 \text{ m/s}^2)$$

1 Newton is the force required to give a mass of 1 kg an acceleration of  $1 \text{ m/s}^2$ .

Weight is a force. The weight of 1 kg Mass is:

$$W = m g \Rightarrow W = (1 \text{ kg}) (9.81 \text{ m/s}^2) = 9.81 \text{ N}$$



# Chapter: 2

## Vectors Forces

### Part 1: Vectors in 2D and 3D

#### Introduction

**Statics:** The study of bodies when they are at rest and all forces are in equilibrium.

Static equations are often used in truss problems. To solve a static equation, engineers use a free body diagram. If an object is at rest, as it is in statics, the sum of the forces acting upon the object will equal zero. The sum of the moments will also equal zero.

#### Scalars and Vectors

**Scalar:** A scalar is any positive or negative physical quantity that can be completely specified by its magnitude

Examples: Examples of scalar quantities include length, mass, and time.

**Vector:** A vector is any physical quantity that requires both a magnitude and a direction for its complete description.

Examples(For instance): Examples of vectors encountered in statics are force, position, and moment.

**Vector** A vector is shown graphically by an arrow. The length of the arrow represents the magnitude of the vector, and the angle between the vector and a fixed axis defines the direction of its line of action . The head or tip of the arrow indicates the sense of direction of the vector (see below Figure )

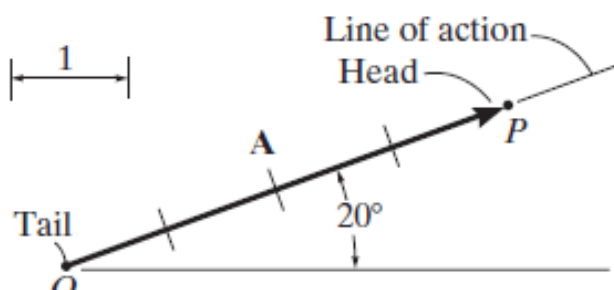

Vector Addition:

All vector quantities obey the parallelogram law of Addition

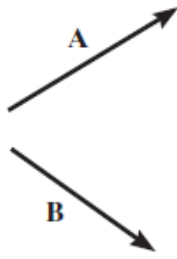

(a)

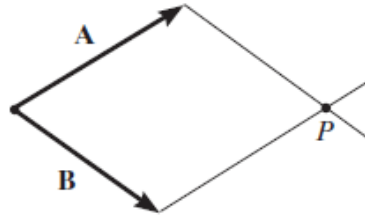

(b)

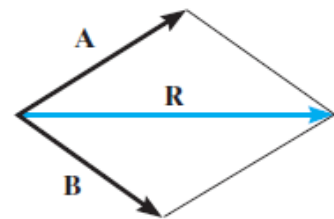

$\mathbf{R} = \mathbf{A} + \mathbf{B}$   
Parallelogram law  
(c)

$$\vec{R} = \vec{A} + \vec{B}$$

**Vector Subtraction.** The resultant of the difference between two vectors A and B of the same type may be expressed as

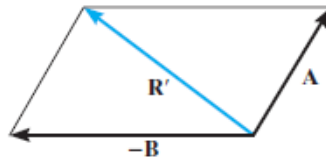
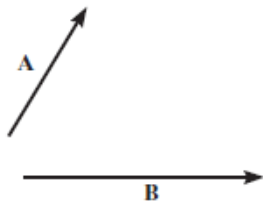

Parallelogram law

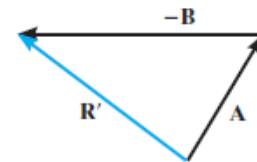

Triangle construction

Vector subtraction

$$\vec{R} = \vec{A} - \vec{B} = +(-\vec{B})$$

## Dot Product

The Dot Product gives a scalar (ordinary number) answer, and is sometimes called the scalar product.

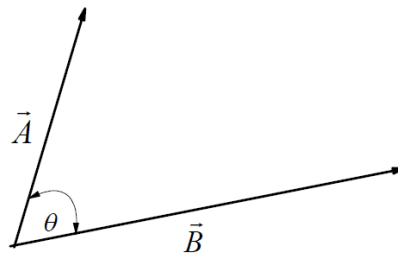

The Dot product define as  $\vec{A} \cdot \vec{B} = AB \cos \theta$

### Laws of Operation

1. Commutative law :

$$\vec{A} \cdot \vec{B} = \vec{B} \cdot \vec{A}$$

2. Multiplication by a scalar  $\lambda (\vec{A} \cdot \vec{B}) = (\lambda \vec{A}) \cdot \vec{B} = \vec{A} \cdot (\lambda \vec{B}) = (\vec{A} \cdot \vec{B}) \lambda$

3. Distribution law :  $\vec{A} \cdot (\vec{B} + \vec{D}) = (\vec{A} \cdot \vec{B}) + (\vec{A} \cdot \vec{D})$

4. Cartesian Vector Formulation

Dot product of two vectors  $\vec{A} = a_x \vec{i} + a_y \vec{j} + a_z \vec{k}$  and  $\vec{B} = b_x \vec{i} + b_y \vec{j} + b_z \vec{k}$  ,

then  $\vec{A} \cdot \vec{B} = a_x b_x + a_y b_y + a_z b_z$

5. Applications: The angle formed between two vectors given by

$$\cos \theta = \frac{\vec{A} \cdot \vec{B}}{|\vec{A}| |\vec{B}|} = \frac{a_x b_x + a_y b_y + a_z b_z}{\sqrt{a_x^2 + a_y^2 + a_z^2} \sqrt{b_x^2 + b_y^2 + b_z^2}}$$

If  $\vec{A} \cdot \vec{B} = 0 \rightarrow \vec{A}$  perpendicular  $\vec{B}$

6- Dot product of Cartesian unit vectors  $\vec{i} \cdot \vec{j} = \vec{j} \cdot \vec{k} = \vec{k} \cdot \vec{i} = 0$  , while

$$\vec{i} \cdot \vec{i} = i^2 = 1, \quad \vec{j} \cdot \vec{j} = j^2 = 1, \quad \vec{k} \cdot \vec{k} = k^2 = 1.$$

**Cross Product**

The Cross Product which gives a vector as an answer, and is sometimes called the vector product. For two vectors define as  $\vec{A} \wedge \vec{B} = AB \sin \theta \vec{e}$  , where  $\vec{e}$  is unite vector in the direction of  $\vec{A} \wedge \vec{B}$

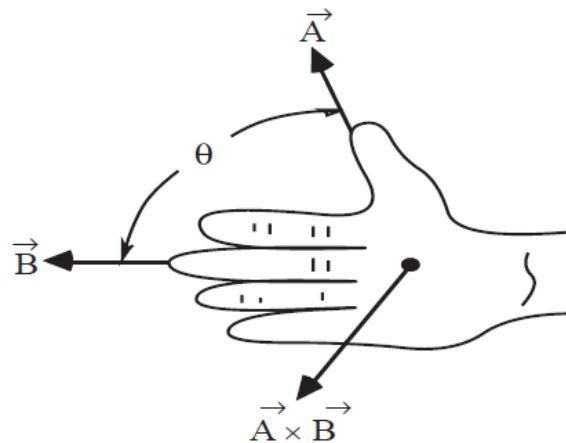

Laws of Operation

1. Commutative law  $\vec{A} \wedge \vec{B} \neq \vec{B} \wedge \vec{A}$  , but  $\vec{A} \wedge \vec{B} = - \vec{A} \wedge \vec{B}$

2. Multiplication by a scalar  $\lambda (\vec{A} \wedge \vec{B}) = (\lambda \vec{A}) \wedge \vec{B} = \vec{A} \wedge (\lambda \vec{B}) = (\vec{A} \wedge \vec{B}) \lambda$

3. Distribution law  $\vec{A} \wedge (\vec{B} + \vec{D}) = (\vec{A} \wedge \vec{B}) + (\vec{A} \wedge \vec{D})$

4. Cartesian Vector Formulation

Cross product of two vectors  $\vec{A} = a_x \vec{i} + a_y \vec{j} + a_z \vec{k}$  and  $\vec{B} = b_x \vec{i} + b_y \vec{j} + b_z \vec{k}$

Then  $\vec{A} \wedge \vec{B} = \begin{vmatrix} \vec{i} & \vec{j} & \vec{k} \\ a_x & a_y & a_z \\ b_x & b_y & b_z \end{vmatrix}$ .

5. Applications :

The angle formed between two vectors given by  $\sin \theta = \frac{|\vec{A} \wedge \vec{B}|}{|\vec{A}| |\vec{B}|}$

6- Cross product of Cartesian unit vectors

$\vec{i} \wedge \vec{j} = \vec{k}$ ,  $\vec{j} \wedge \vec{k} = \vec{i}$ ,  $\vec{k} \wedge \vec{i} = \vec{j}$ , while

$\vec{i} \wedge \vec{i} = 0$ ,  $\vec{j} \cdot \vec{j} = 0$ ,  $\vec{k} \cdot \vec{k} = 0$ , see below figure

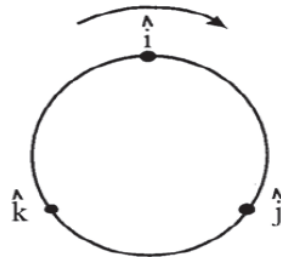

Triple Scalar Product

For three vectors  $\vec{A}, \vec{B}, \vec{C}$  the Triple Scalar Product define as

Note  $\vec{A} \cdot (\vec{B} \wedge \vec{C}) = \begin{vmatrix} a_x & a_y & a_z \\ b_x & b_y & b_z \\ c_x & c_y & c_z \end{vmatrix}$

that  $\vec{A} \cdot (\vec{B} \wedge \vec{C}) = (\vec{B} \wedge \vec{C}) \cdot \vec{A}$ , (1)

$\vec{A} \cdot (\vec{B} \wedge \vec{C}) = (\vec{B} \wedge \vec{C}) \cdot \vec{A}$ , (2)

$\vec{A} \cdot (\vec{B} \wedge \vec{C}) = \vec{C} \cdot (\vec{A} \wedge \vec{B}) = \vec{B} \cdot (\vec{C} \wedge \vec{A})$  (3)

$\vec{A} \cdot (\vec{B} \wedge \vec{C}) = -\vec{A} \cdot (\vec{C} \wedge \vec{B}) = -\vec{B} \cdot (\vec{A} \wedge \vec{C})$ , see below figure

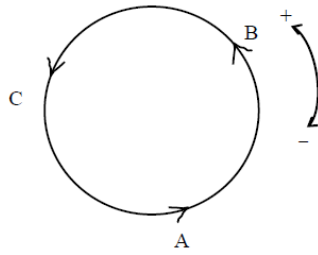

(4)- Triple Scalar Product represents the volume of parallelepiped  
 $\vec{A} \cdot (\vec{B} \wedge \vec{C}) =$  the volume of parallelepiped

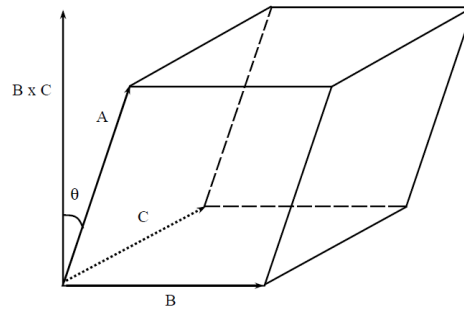

### Triple Vector Product

For three vectors  $\vec{A}, \vec{B}, \vec{C}$  the Triple Vector Product define as  $\vec{A} \wedge (\vec{B} \wedge \vec{C})$

Note that

(1)-  $\vec{A} \wedge (\vec{B} \wedge \vec{C}) \neq \vec{A} \wedge (\vec{C} \wedge \vec{B})$ ,

(2)-  $\vec{A} \wedge (\vec{B} \wedge \vec{C}) = (\vec{A} \cdot \vec{C})\vec{B} - (\vec{A} \cdot \vec{B})\vec{C}$  ,( prove that this property?)

### Unit vector

A unit vector is a vector that has a magnitude of 1

$$\text{Unit vector} = \frac{\text{Vector}}{\text{Magnitude of the vector}}$$

Example 1: Given a vector  $\vec{r} = 4\vec{i} - 3\vec{j}$  , find the unit vector?

### Solution

$$r = |\vec{r}| = \sqrt{(4)^2 + (-3)^2} = \sqrt{16+9} = \sqrt{25} = 5$$

$$\vec{u} = \frac{\vec{r}}{|\vec{r}|} = \frac{4}{5}\vec{i} - \frac{3}{5}\vec{j} = \frac{1}{5}(4, -3)$$

# Cartesian vector

## Introduction

The operations of vector algebra, when applied to solving problems in three dimensions, are greatly simplified if the vectors are first represented in Cartesian vector form. In this section we will present a general method for doing this; then in the next section we will use this method for finding the resultant force of a system of concurrent forces.

## Right-Handed Coordinate System.

We will use a right-handed coordinate system to develop the theory of vector algebra that follows. A rectangular coordinate system is said to be right-handed if the thumb of the right hand points in the direction of the positive  $z$  axis when the right-hand fingers are curled about this axis and directed from the positive  $x$  towards the positive  $y$  axis, as in Figure.

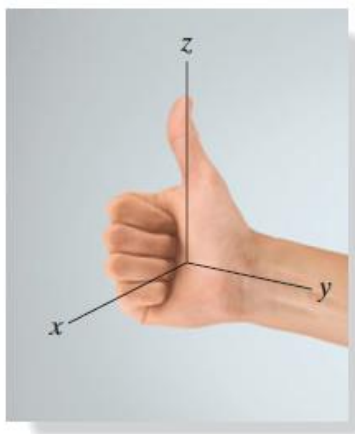

## Position Vectors

Here we will introduce the concept of a position vector. It will be shown that this vector is of importance in formulating a Cartesian force vector directed between two points in space.

A position vector  $\vec{A}$  is defined as a fixed vector which locates a point in space relative to another point. For example, if  $\vec{A}$  extends from the origin of

coordinates,  $O$ , to point  $P(x, y, z)$  (Fig. a), then  $\vec{A}$  can be expressed in Cartesian vector form as

$$\vec{A} = a_x \vec{i} + a_y \vec{j} + a_z \vec{k}$$

Note how the head-to-tail vector addition of the three components yields vector  $r$  (Fig. b). Starting at the origin  $O$ , one “travels”  $x$  in the  $+i$  direction, then  $y$  in the  $+j$  direction, and finally  $z$  in the  $+k$  direction to arrive at point  $P(x, y, z)$

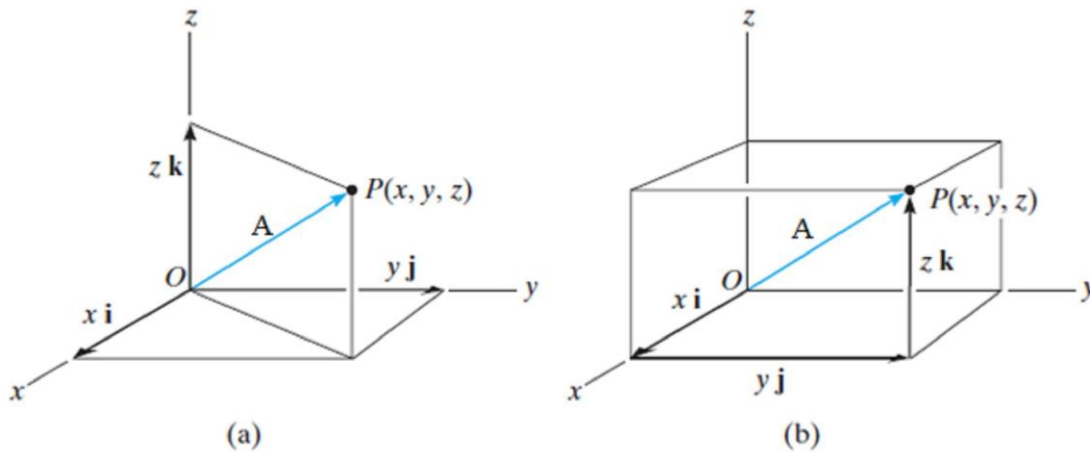

### **Rectangular Components of a Vector.**

A vector  $A$  may have one, two, or three rectangular components along the  $x, y, z$  coordinate axes, depending on how the vector is oriented relative to the axes. In general, though, when  $A$  is directed within an octant of the  $x, y, z$  frame ( see front Figure), then by two successive applications of the parallelogram law, we may resolve the vector into components as  $A = A' + A_z$  and then  $A' = A_x + A_y$ . Combining these equations, to eliminate  $A'$ ,  $A$  is represented by the vector sum of its three rectangular components,

$$A = A_x + A_y + A_z$$

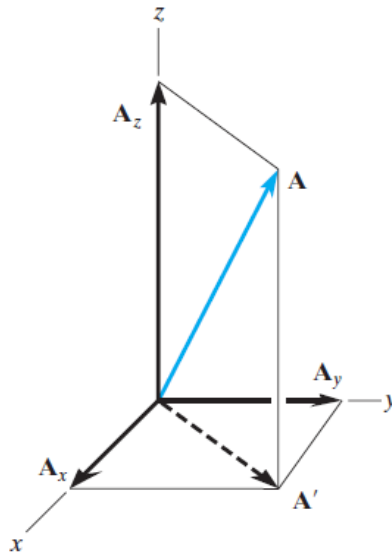

### **Cartesian Unit Vectors.**

In three dimensions, the set of Cartesian unit vectors,  $i, j, k$  is used to designate the directions of the  $x, y, z$  axes, respectively. The sense (or arrowhead) of these vectors will be represented analytically by a plus or minus sign, depending on whether they are directed along the positive or negative  $x, y$  or  $z$  axes. The positive Cartesian unit vectors are shown in Figure.

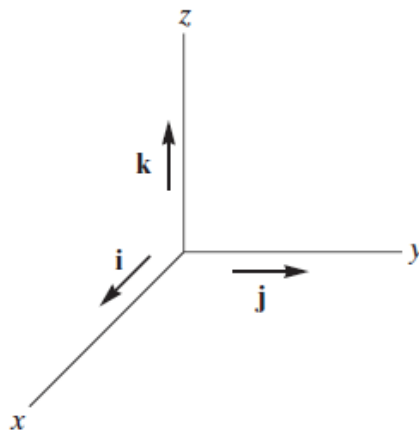

### **Cartesian Vector Representation.**

Since the three components of  $\vec{A}$  in above equation act in the positive  $\vec{i}, \vec{j}$  and  $\vec{k}$  directions (see Figure) , we can write  $\vec{A}$  in Cartesian vector

$$\text{form as } \vec{A} = a_x \vec{i} + a_y \vec{j} + a_z \vec{k}$$



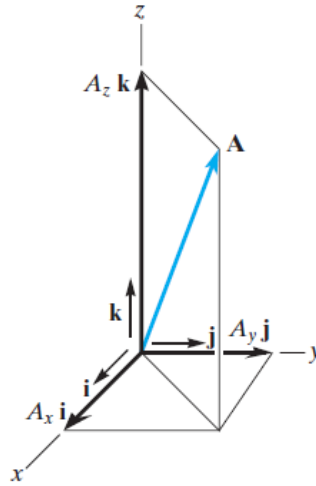

### **Magnitude of a Cartesian Vector.**

The magnitude of a Cartesian vector is  $\vec{A} = \sqrt{(a_x)^2 + (a_y)^2 + (a_z)^2}$ . The

magnitude of  $\vec{A}$  is equal to the positive square root of the sum of the squares of its components.

### **Direction of a Cartesian Vector.**

We will define the direction of  $\vec{A}$  by the coordinate direction angles  $\alpha, \beta, \gamma$ , measured between the tail of  $\vec{A}$  and the positive  $x, y, z$  axes provided they are located at the tail of  $\vec{A}$  (see Figure). Note that regardless of where  $\vec{A}$  is directed, each of these angles will be between  $0^\circ$  and  $180^\circ$ .

The angles  $\alpha, \beta, \gamma$  given by  $\cos \alpha = \frac{a_x}{A}$ ,  $\cos \beta = \frac{a_y}{A}$ ,  $\cos \gamma = \frac{a_z}{A}$

From this Eq. we have  $A^2 \cos \alpha = a_x^2$ ,  $A^2 \cos \beta = a_y^2$ ,  $A^2 \cos \gamma = a_z^2$

$A^2 \left( \cos^2 \alpha + \cos^2 \beta + \cos^2 \gamma \right) = a_x^2 + a_y^2 + a_z^2 = A^2$ . Then

$$\cos^2 \alpha + \cos^2 \beta + \cos^2 \gamma = 1$$

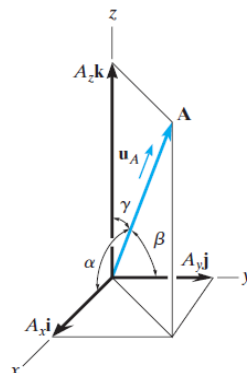

**Note that, the unit vector given by**

$$\vec{A}_u = \frac{a_x}{A} \vec{i} + \frac{a_y}{A} \vec{j} + \frac{a_z}{A} \vec{k}. \text{ Also given by } \vec{A}_u = \cos\alpha \vec{i} + \cos\beta \vec{j} + \cos\gamma \vec{k}.$$

Then the direction of vector  $\vec{A}$  given by

$$\cos\alpha = \frac{a_x}{A}, \quad \cos\beta = \frac{a_y}{A}, \quad \cos\gamma = \frac{a_z}{A}$$

**In the space represent the force as:**

(1) If we know two angles with two axes

In this case  $\cos^2 \alpha + \cos^2 \beta + \cos^2 \gamma = 1$  and the force given by

$$\vec{F} = F \cos\alpha \vec{i} + F \cos\beta \vec{j} + F \cos\gamma \vec{k}$$

(2) If we know an angles with two axes in plane

In this case we resolve the force in the vertical axis and in the other plane

(3) If we know the unite vector in space

In this case  $\vec{A}_u = \frac{a_x}{A} \vec{i} + \frac{a_y}{A} \vec{j} + \frac{a_z}{A} \vec{k}$ ,  $\vec{A}_u = \cos\alpha \vec{i} + \cos\beta \vec{j} + \cos\gamma \vec{k}$ , and

$$\cos\alpha = \frac{a_x}{A}, \quad \cos\beta = \frac{a_y}{A}, \quad \cos\gamma = \frac{a_z}{A}.$$

Example 2: Given a vector  $\vec{r} = 12\vec{i} - 3\vec{j} - 4\vec{k}$ , find the unit vector?

**Solution**

$$r = |\vec{r}| = \sqrt{(12)^2 + (-3)^2 + (-4)^2} = \sqrt{144 + 9 + 16} = \sqrt{169} = 13$$

$$\vec{u} = \frac{\vec{r}}{|\vec{r}|} = \frac{12}{13} \vec{i} - \frac{3}{13} \vec{j} - \frac{4}{13} \vec{k} = \frac{1}{13} (12, -3, 4)$$

Example 3: Determine the length and its direction measured from  $B$  toward  $A$  as shown in Figure?

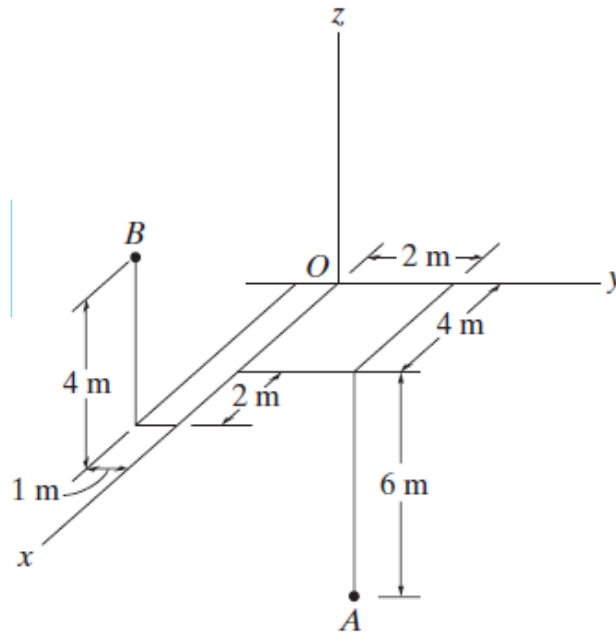

### Solution

The coordinates of A and B are  $B(6, -1, 4)$ ,  $A(4, 2, -6)$

$$\vec{AB} = \vec{r} = (6-4)\vec{i} + (-1-2)\vec{j} + (4-(-6))\vec{k}$$

$$\vec{r} = 2\vec{i} - 3\vec{j} + 10\vec{k}$$

$$r = |\vec{r}| = \sqrt{(2)^2 + (-3)^2 + (10)^2} = \sqrt{4 + 9 + 100} = \sqrt{113}$$

$$\vec{u} = \frac{\vec{AB}}{|\vec{AB}|} = \frac{\vec{r}}{|\vec{r}|} = \frac{2}{\sqrt{113}}\vec{i} - \frac{3}{\sqrt{113}}\vec{j} + \frac{10}{\sqrt{113}}\vec{k}$$

The direction of  $\vec{AB} = \vec{r}$  given by

$$\cos\alpha = \frac{\vec{r}_x}{r}, \quad \cos\beta = \frac{\vec{r}_y}{r}, \quad \cos\gamma = \frac{\vec{r}_z}{r}$$

$$\cos\alpha = \frac{2}{\sqrt{113}}, \quad \cos\beta = -\frac{3}{\sqrt{113}}, \quad \cos\gamma = \frac{10}{\sqrt{113}}$$

$$\alpha = \cos^{-1}\left(\frac{2}{\sqrt{113}}\right) = 79.15545231^\circ,$$

$$\beta = \cos^{-1}\left(-\frac{3}{\sqrt{113}}\right) = 106.3927403^\circ,$$

$$\gamma = \cos^{-1}\left(\frac{10}{\sqrt{113}}\right) = 19.8136573^\circ$$

Example 4: An elastic rubber band is attached to points  $A$  and  $B$  as shown in Figure . Determine its length and its direction measured from  $A$  toward  $B$  ?

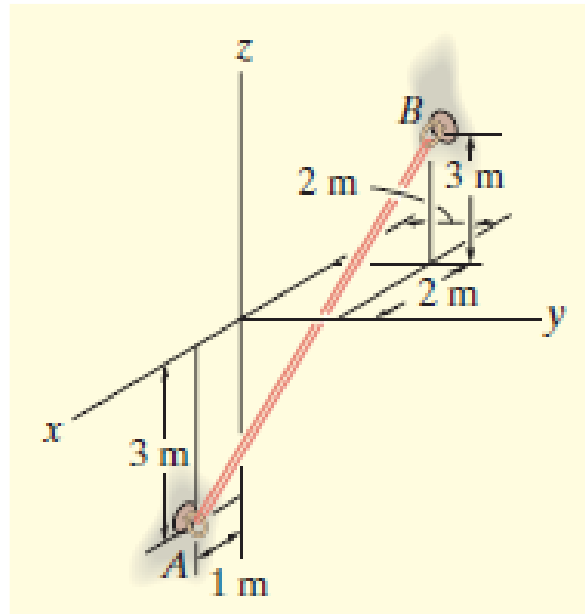

### Solution

The coordinates A and B are  $A(1, 0, -3)$  ,  $B(-2, 2, 3)$

$$\vec{AB} = \vec{r} = (-2 - (-1))\vec{i} + (2 - 0)\vec{j} + (3 - (-3))\vec{k}$$

$$\vec{r} = -3\vec{i} + 2\vec{j} + 6\vec{k}$$

$$r = |\vec{r}| = \sqrt{(-3)^2 + (2)^2 + (6)^2} = \sqrt{9 + 4 + 36} = \sqrt{49} = 7$$

$$\vec{u} = \frac{\vec{AB}}{|\vec{AB}|} = \frac{\vec{r}}{|\vec{r}|} = -\frac{3}{7}\vec{i} + \frac{2}{7}\vec{j} + \frac{6}{7}\vec{k}$$

The direction of  $\vec{AB} = \vec{r}$  given by,  $\cos\alpha = \frac{\vec{r}_x}{r}$ ,  $\cos\beta = \frac{\vec{r}_y}{r}$ ,  $\cos\gamma = \frac{\vec{r}_z}{r}$

Then  $\cos\alpha = -\frac{3}{7}$ ,  $\cos\beta = \frac{2}{7}$ ,  $\cos\gamma = \frac{6}{7}$ . This tends to

$$\alpha = \cos^{-1}\left(-\frac{3}{7}\right) = 115.376^\circ, \quad \beta = \cos^{-1}\left(\frac{2}{7}\right) = 73.398^\circ,$$

$$\gamma = \cos^{-1}\left(\frac{6}{7}\right) = 31^\circ$$

## Part 2: Vectors Forces in 2D and 3D

### Resultant of Concurrent Coplanar Forces

How to calculate the resultant force acting on an object?

Several forces can act on a body or point, each force having different direction and magnitude. In engineering the focus is on the resultant force acting on the body.

The resultant of concurrent forces (acting in the same plane) can be found using the parallelogram law, the triangle rule or the polygon rule..

Two or more forces are concurrent if their direction crosses through a common point. For example, two concurrent forces  $F_1$  and  $F_2$  are acting on the same point P. In order to find their resultant  $F$ , we can apply either the parallelogram law, triangle rule.

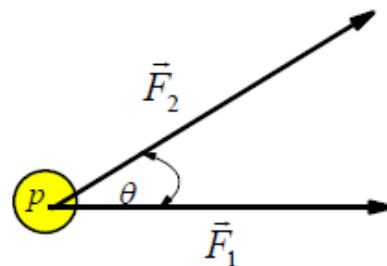

Fig. 1

A force is a vector quantity since it has magnitude and direction. Therefore, the force addition will be according to the Parallelogram law

### Parallelogram in 2D:

Redraw a half portion of the parallelogram to illustrate the triangular head-to-tail addition of the components. From this triangle, the magnitude of the resultant force can be determined using the law of *Cosine*, and its direction is determined from the law of *Sine*. The magnitudes of two force components are determined from the law of *Sine*. The formulas are given in Figure.

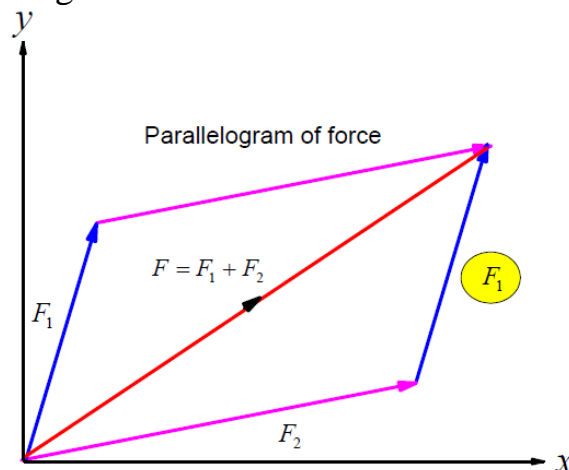

Fig. 2 (a)

From the triangle force, the resultant force is the vector sum between the components:

$$\vec{F} = \vec{F}_1 + \vec{F}_2$$

Cosine law is  $F = \sqrt{F_1^2 + F_2^2 - 2F_1F_2 \cos \alpha}$

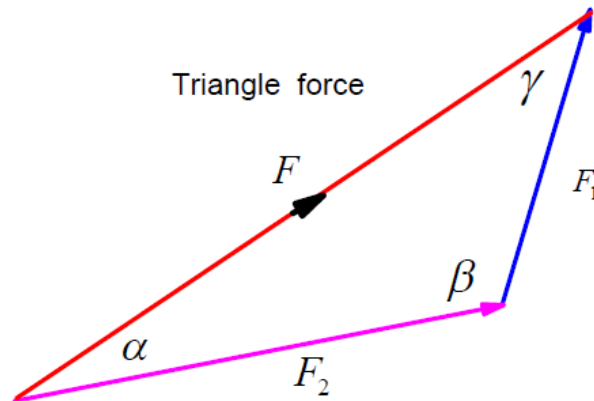

Fig. 2 (b)

Sine law is  $\frac{F_1}{\sin \alpha} = \frac{F_2}{\sin \gamma} = \frac{F}{\sin \beta}$

### Components

Also, we can find the resultant of Concurrent Coplanar Forces as

Step 1: to resolve each force into its  $x - y$  components.

Step 2: to add all the  $x$  components together and add all the  $y$  components together.

These two totals become the resultant vector.

Step 3: find the magnitude and the angle of the resultant vector.

I. e, we calculate both  $\sum F_x$  and  $\sum F_y$ , then the resultant is

$$F = \sqrt{(\sum F_x)^2 + (\sum F_y)^2}$$

The direction is  $\theta = \tan^{-1} \left( \frac{\sum F_y}{\sum F_x} \right)$ .

Final, the results for two forces can calculate by

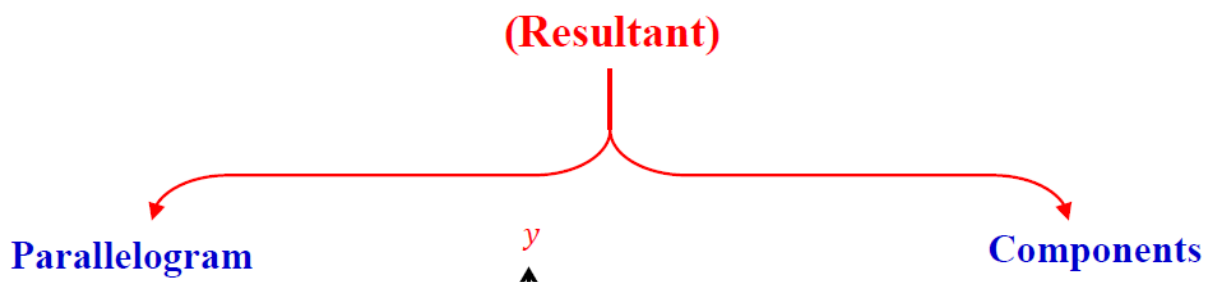

Example 1: If  $\theta=60^\circ$  and  $F=450\text{ N}$ , determine the magnitude of the resultant force and its direction, measured counterclockwise from the positive  $x$  – axis.

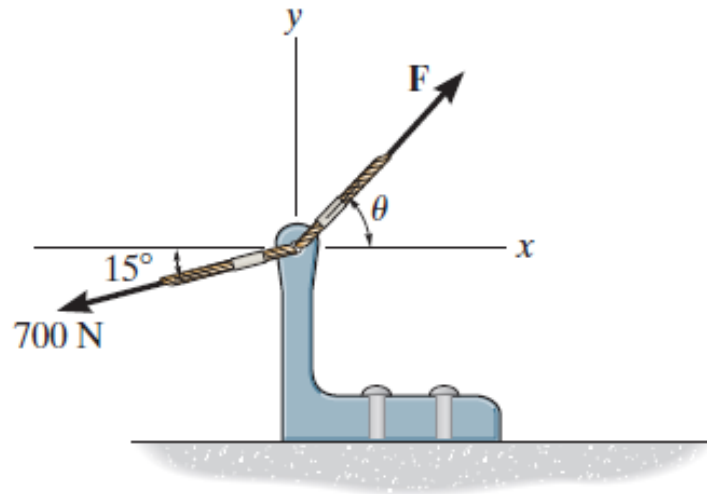

### Solution

We can draw the forces as in below Figure (Free-Body Diagrams)

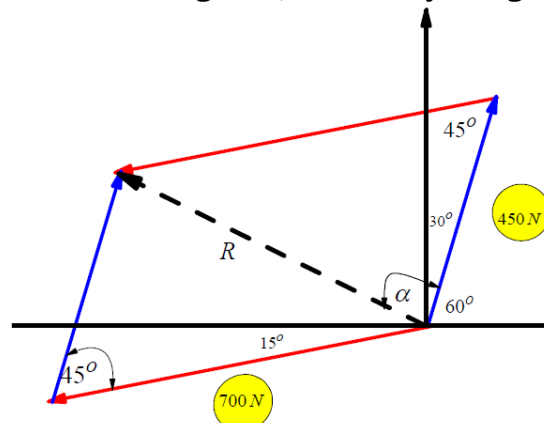

Fig. (1)

Applying the law of Cosine to Fig. (1), This yields

$$F_R = \sqrt{(700)^2 + (450)^2 - 2(700)(450)\cos 45^\circ} = 497\text{ N}$$

Again, applying the law of Sine to Fig. (1), and using this result, yields

$$\frac{\sin(\alpha + 30^\circ)}{700} = \frac{\sin 45^\circ}{497.01} \rightarrow \alpha = 95.19^\circ$$

Thus, the direction of angle of measured counterclockwise from the positive  $x$  – axis is  $\phi = \alpha + 60^\circ = 95.19^\circ + 60^\circ = 155.19^\circ$

Do you can solve the previous problem using the components method?

Example 2: The vertical force  $F$  acts downward at  $A$  on the two membered frame. Determine the magnitudes of the two components of  $F$  directed along the axes of  $BA$  and  $AC$ . Set  $F = 500$ ?

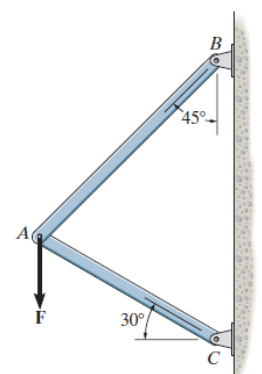

## Solution

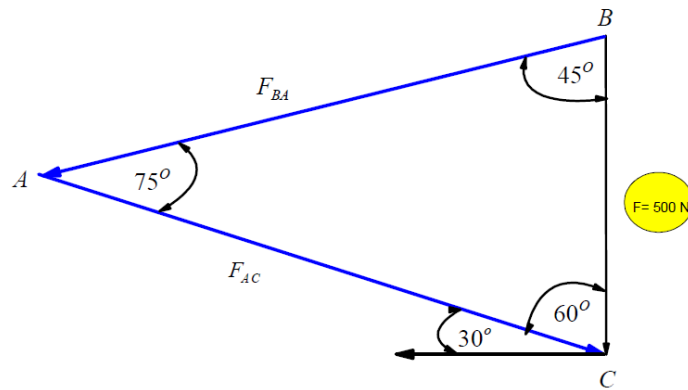

From the Cosine law  $F = \sqrt{F_1^2 + F_2^2 - 2F_1F_2 \cos \alpha}$

$$F = \sqrt{(6)^2 + (4)^2 - 2(6)(4)\cos 105^\circ} = \sqrt{36 + 16 - (48)(-0.2588)}$$

$$= \sqrt{52 + 12.423} = \sqrt{64.423} = 8.03 \text{ N}$$

From the Sine law  $\frac{F}{\sin 105^\circ} = \frac{F_1}{\sin \alpha} \rightarrow \sin \alpha = \frac{F_1}{F} \sin 105^\circ =$

$$\frac{4}{8.03}(0.9659) = \frac{3.8637}{8.03} = 0.4811 \rightarrow \alpha = 28.761$$

Then  $\theta = 28.761 - 25 = 3.761^\circ$

**Example 3:** Determine the magnitude of the resultant force (see below Figure) and its direction, measured counterclockwise from the positive x axis ?

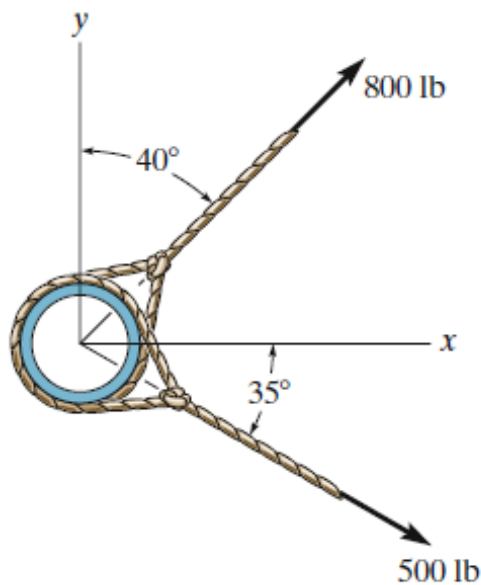

## Solution



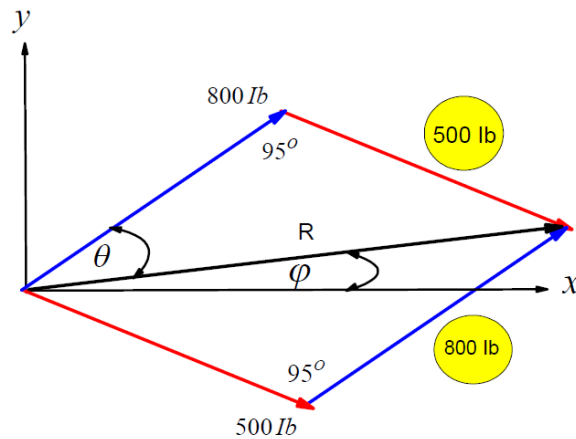

From the Cosine law  $F = \sqrt{F_1^2 + F_2^2 - 2F_1F_2 \cos \alpha}$

$$R = \sqrt{(500)^2 + (800)^2 - 2(500)(800)\cos 95^\circ} = \sqrt{(500)^2 + (800)^2 - 2(500)(800)(-0.08715)}$$

$$= \sqrt{250000 + 640000 + 69724.594} = \sqrt{959724.594} = 979.65539 = 980 \text{ lb}$$

Using this result to apply the sine law

$$\frac{R}{\sin 95^\circ} = \frac{500}{\sin \theta} \rightarrow \frac{980}{\sin 95^\circ} = \frac{500}{\sin \theta} \rightarrow \sin \theta = 500 \frac{980}{\sin 95^\circ} = 500 \left( \frac{0.9961}{980} \right) = 0.5082$$

$$\theta = \sin^{-1}(0.5082) \rightarrow \theta = 30.54495^\circ$$

Thus, the direction of  $R$  measured counterclockwise from the positive  $x$  axis is

$$\theta = 50 - 30.54495^\circ = 19.54^\circ$$

Example 4: The force  $F$  has a magnitude of  $80 \text{ lb}$  and acts within the octant shown. Determine the magnitudes of the  $x$ ,  $y$ ,  $z$  components of  $F$ ?

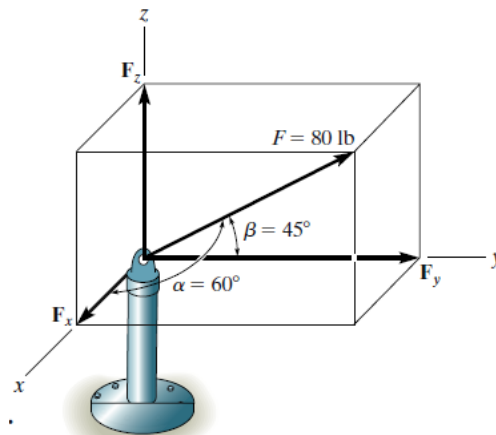

### Solution

From the Figure clears that  $\alpha = 60^\circ$  and  $\beta = 45^\circ$  and using the relation

$$\cos^2 \alpha + \cos^2 \beta + \cos^2 \gamma = 1, \text{ we find that } (\cos(60^\circ))^2 + (\cos(45^\circ))^2 + \cos^2 \gamma = 1$$

$$(0.5)^2 + \left( \frac{1}{\sqrt{2}} \right)^2 + \cos^2 \gamma = 1 \rightarrow 0.25 + 0.5 + \cos^2 \gamma = 1 \rightarrow \cos^2 \gamma = 0.25 \quad \cos^2 \gamma = \pm 0.5 \rightarrow \gamma = 60^\circ$$

Or  $\gamma = 120^\circ$

By inspection it is necessary that  $\gamma = 60^\circ$ , since  $F_x$  must be in the  $+x$

Now using the relation  $\vec{F} = F \cos \alpha \vec{i} + F \cos \beta \vec{j} + F \cos \gamma \vec{k}$ , we have

$$\vec{F} = 80(\cos 60^\circ \vec{i} + \cos 45^\circ \vec{j} + \cos 60^\circ \vec{k})$$

$$\vec{F} = 80\left(0.5\vec{i} + \frac{1}{\sqrt{2}}\vec{j} + 0.5\vec{k}\right) = 80\left(0.5\vec{i} + \frac{\sqrt{2}}{(\sqrt{2})(\sqrt{2})}\vec{j} + 0.5\vec{k}\right)$$

$$\vec{F} = 80(0.5\vec{i} + (0.5)(\sqrt{2})\vec{j} + 0.5\vec{k}) = 40(\vec{i} + \sqrt{2}\vec{j} + \vec{k})$$

$$\text{So, } \vec{F}_x = 40\text{ lb, } \vec{F}_y = 40\sqrt{2}\text{ lb, } \vec{F}_z = 40\text{ lb}$$

$$\text{Not that } F = 40\sqrt{1+2+1} = 40\sqrt{4} = 40(2) = 80\text{ lb}$$

**Example 5:** The bolt is subjected to the force  $F$ , which has components acting along the  $x$ ,  $y$ ,  $z$  axes as shown. If the magnitude of  $F$  is  $80\text{ N}$ ,  $\alpha = 60^\circ$  and  $\gamma = 45^\circ$  determine the magnitudes of its components (see below Figure).

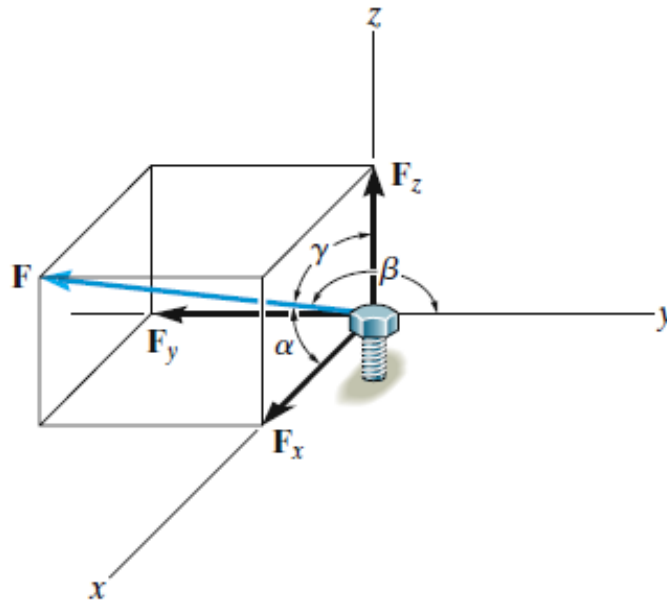

### Solution

From the Figure clears that  $\alpha = 60^\circ$  and  $\gamma = 45^\circ$  and using the relation  $\cos^2 \alpha + \cos^2 \beta + \cos^2 \gamma = 1$ , we find that  $(\cos(60^\circ))^2 + \cos^2 \beta + (\cos(45^\circ))^2 = 1$

$$(0.5)^2 + \cos^2 \beta + \left(\frac{1}{\sqrt{2}}\right)^2 = 1 \rightarrow 0.25 + \cos^2 \beta + 0.5 = 1 \rightarrow \cos^2 \beta = 0.25$$

$$\cos^2 \beta = \pm 0.5 \rightarrow \beta = 60^\circ \text{ Or } \beta = 120^\circ$$

By inspection it is necessary that  $\beta = 120^\circ$ , since  $F_x$  must be in the  $+x$

Now using the relation  $\vec{F} = F \cos \alpha \vec{i} + F \cos \beta \vec{j} + F \cos \gamma \vec{k}$ , we have

$$\vec{F} = 80(\cos 60^\circ \vec{i} + \cos 120^\circ \vec{j} + \cos 45^\circ \vec{k})$$

$$\vec{F} = 80\left(0.5\vec{i} - 0.5\vec{j} + \frac{1}{\sqrt{2}}\vec{k}\right) = 80\left(0.5\vec{i} - 0.5\vec{j} + \frac{\sqrt{2}}{(\sqrt{2})(\sqrt{2})}\vec{k}\right)$$

$$\vec{F} = 80(0.5\vec{i} - (0.5)\vec{j} + 0.5(\sqrt{2})\vec{k}) = 40(\vec{i} - \vec{j} + \sqrt{2}\vec{k})$$

$$\text{So, } \vec{F}_x = 40\text{ N, } \vec{F}_y = 40\text{ N, } \vec{F}_z = 40\sqrt{2}\text{ N}$$

**Example 6:** Express the force  $F$  shown in Figure as a Cartesian vector and its direction?

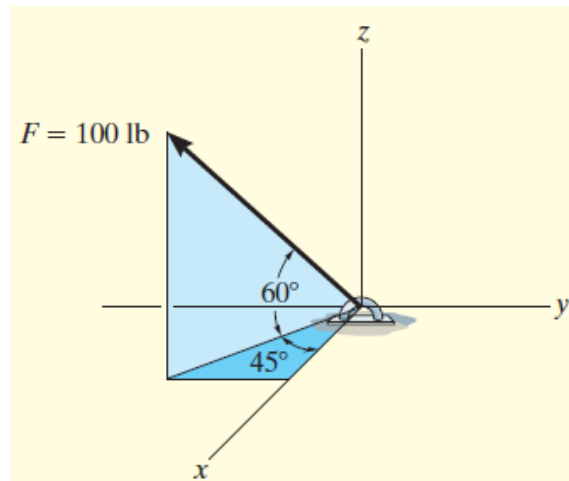

## Solution

If we resolve the force as in Figure

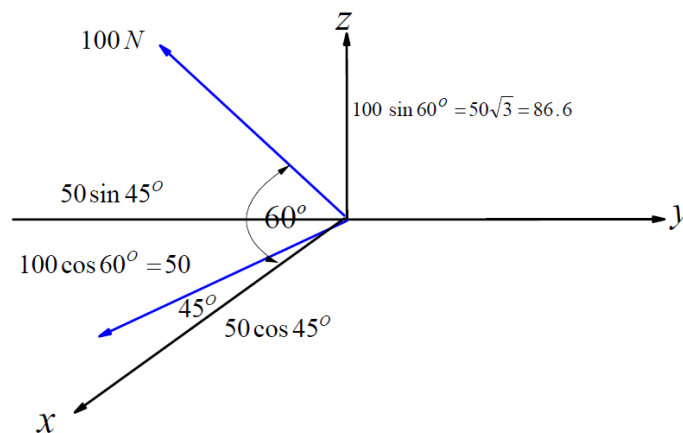

Then  $\vec{F} = (50\cos 45^\circ \vec{i} - 50\sin 45^\circ \vec{j} + 86.6\vec{k})$

$$\vec{F} = \left( \frac{50}{\sqrt{2}} \vec{i} - \frac{50}{\sqrt{2}} \vec{j} + 86.6\vec{k} \right)$$

$$\vec{F} = (35.4 \vec{i} - 35.4 \vec{j} + 86.6\vec{k})$$

Not that  $F = \sqrt{(35.4)^2 + (35.4)^2 + (86.6)^2} = \sqrt{10005} \cong 100 \text{ N}$

The direction of the force given by

$$\cos \alpha = \frac{F_x}{F}, \quad \cos \beta = \frac{F_y}{F}, \quad \cos \gamma = \frac{F_z}{F}$$

$$\cos \alpha = \frac{35.4}{100}, \quad \cos \beta = -\frac{35.4}{100}, \quad \cos \gamma = \frac{86.6}{100}$$

$$\alpha = \cos^{-1}\left(\frac{35.4}{100}\right) = 69.3^\circ, \quad \beta = \cos^{-1}\left(-\frac{35.4}{100}\right) = 110.73^\circ, \quad \gamma = \cos^{-1}\left(\frac{86.6}{100}\right) = 30^\circ$$

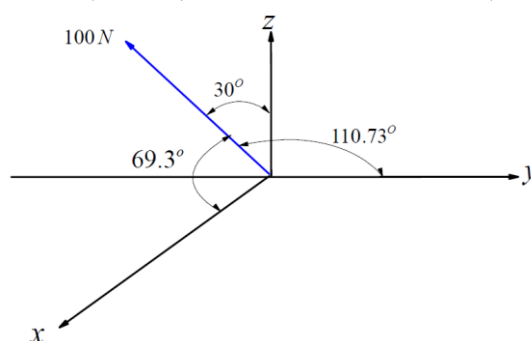

**Example 7:** Two forces act on the hook shown in the Figure. Specify the magnitude of  $F_2$  and its coordinate direction angles so that the resultant force  $F_R$  acts along the positive  $y$  axis and has a magnitude of  $800\text{ N}$ .

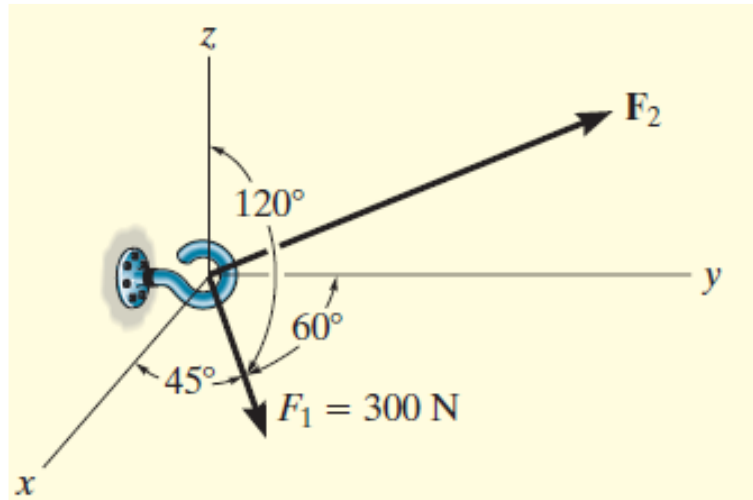

### Solution

Free-Body Diagram. we can plot the Free-Body Diagram as in figure

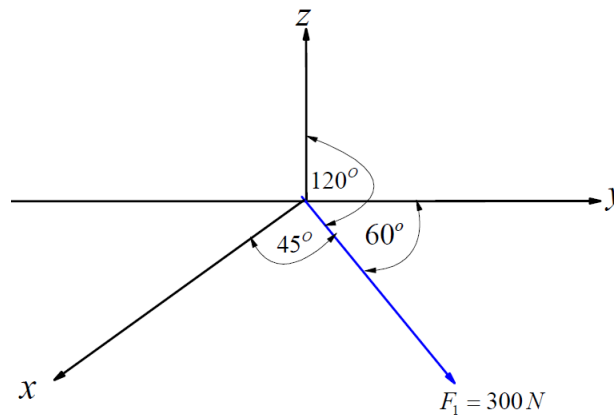

So, we can express  $\vec{F}_1$  as follows:

$$\vec{F}_1 = 300(\cos 45^\circ \vec{i} + \cos 60^\circ \vec{j} + \cos 120^\circ \vec{k}) \quad \vec{F}_1 = 300\left(\frac{1}{\sqrt{2}} \vec{i} + 0.5 \vec{j} - 0.5 \vec{k}\right) = 150(\sqrt{2} \vec{i} + \vec{j} - \vec{k}).$$

Also,  $\vec{F}_R = 800 \vec{j}$

We require  $\vec{F}_R = \vec{F}_1 + \vec{F}_2$  (see below Figure)

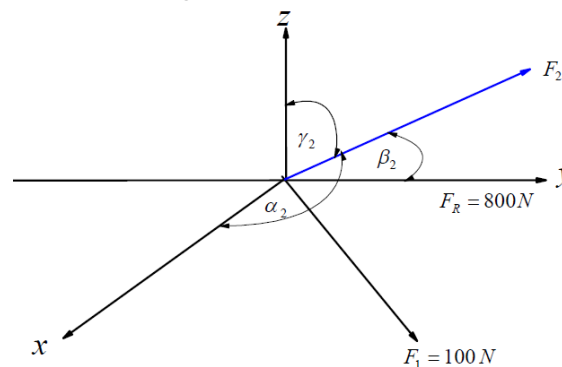

Then

$$800 \vec{j} = 150(\sqrt{2} \vec{i} + \vec{j} - \vec{k}) + F_{2x} \vec{i} + F_{2y} \vec{j} + F_{2z} \vec{k}$$

$$F_{2x} = -150\sqrt{2}, \quad F_{2y} = 650, \quad F_{2z} = 150$$

$$F_2 = \sqrt{(F_{2x})^2 + (F_{2y})^2 + (F_{2z})^2} = \sqrt{45000 + 422500 + 22500} = \sqrt{490000} = 700 \quad \text{The direction of}$$

$$F_2 \text{ given from } \cos\alpha_2 = \frac{F_{x2}}{F_2}, \quad \cos\beta_2 = \frac{F_{y2}}{F_2}, \quad \cos\gamma_2 = \frac{F_{z2}}{F_2}$$

$$\alpha_2 = \cos^{-1}\left(-\frac{150\sqrt{2}}{700}\right) = 107.64^\circ, \quad \beta_2 = \cos^{-1}\left(\frac{650}{700}\right) = 21.8^\circ, \quad \gamma_2 = \cos^{-1}\left(\frac{150}{700}\right) = 77.6^\circ$$

**Example 8:** The screw eye is subjected to the two forces as shown below Figure. Express each force in Cartesian vector form and then determine the resultant force. Find the magnitude and coordinate direction angles of the resultant force.

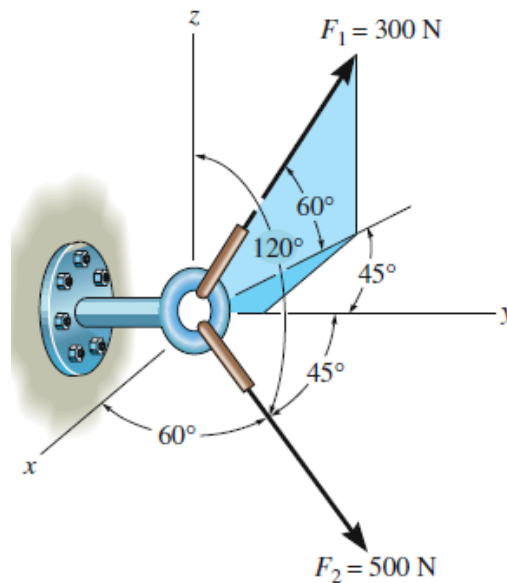

**Solution**

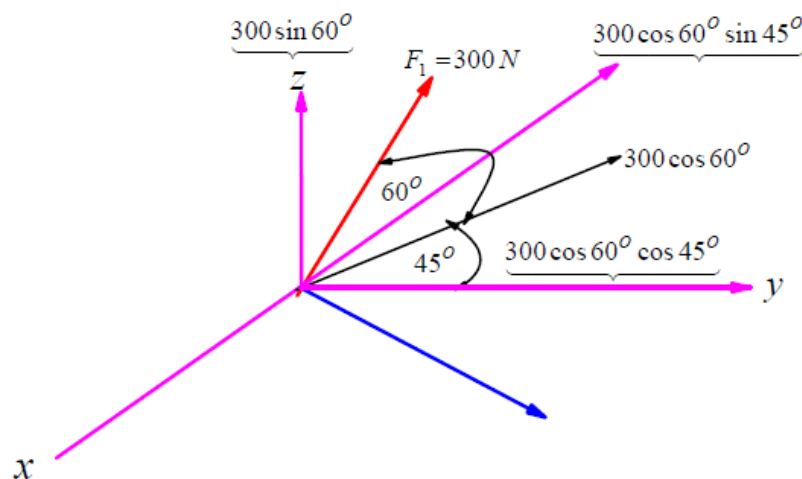

$$\vec{F}_1 = 300(-\cos 60^\circ \sin 45^\circ \vec{i} + \cos 60^\circ \cos 45^\circ \vec{j} + \sin 60^\circ \vec{k})$$

$$\vec{F}_1 = 300\left(-0.5\left(\frac{1}{\sqrt{2}}\right) \vec{i} + 0.5\left(\frac{1}{\sqrt{2}}\right) \vec{j} + \frac{\sqrt{3}}{2} \vec{k}\right)$$

$$\vec{F}_1 = 300(-0.3535 \vec{i} + 0.3535 \vec{j} + 1.732 \vec{k})$$

$$\vec{F}_1 = (-106.07) \vec{i} + 106.07 \vec{j} + 259.81 \vec{k}$$

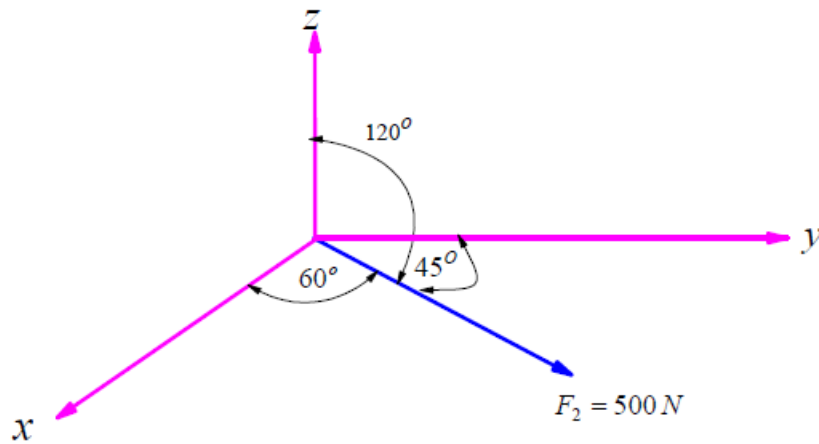

Using the relation  $\vec{F} = F \cos\alpha \vec{i} + F \cos\beta \vec{j} + F \cos\gamma \vec{k}$ , we have

$$\vec{F}_2 = 500(\cos 60^\circ \vec{i} + \cos 45^\circ \vec{j} + \cos 120^\circ \vec{k})$$

$$\vec{F}_2 = 500\left(0.5 \vec{i} + \frac{1}{\sqrt{2}} \vec{j} - 0.5 \vec{k}\right)$$

$$\vec{F}_2 = 500(0.5 \vec{i} + 0.7071 \vec{j} - 0.5 \vec{k})$$

$$\vec{F}_2 = (250 \vec{i} + 353.5542 \vec{j} - 250 \vec{k})$$

So, the resultant is given by

$$\vec{F}_R = \vec{F}_1 + \vec{F}_2 = (-106.07 \vec{i} + 106.07 \vec{j} + 259.81 \vec{k}) + (250 \vec{i} + 353.5542 \vec{j} - 250 \vec{k})$$

$$\vec{F}_R = (143.93 \vec{i} + 459.62 \vec{j} + 9.81 \vec{k})$$

$$F_R = \sqrt{(143.93)^2 + (459.62)^2 + (9.81)^2} = 481.73 \text{ N}$$

$$\cos\alpha = \frac{143.93}{481.73} = 0.298777 \quad \rightarrow \quad \alpha = \cos^{-1}(0.298777) = 72.6158^\circ$$

$$\cos\beta = \frac{459.62}{481.73} = 0.9541 \quad \rightarrow \quad \beta = \cos^{-1}(0.9541) = 17.42^\circ$$

$$\cos\gamma = \frac{9.81}{481.73} = 0.0203 \quad \rightarrow \quad \gamma = \cos^{-1}(0.0203) = 88.833^\circ$$

**Example 9:** Determine the coordinate direction angles of  $F_1$ .

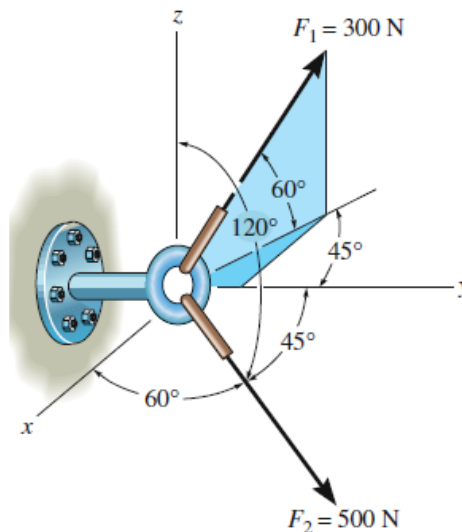

**Solution**

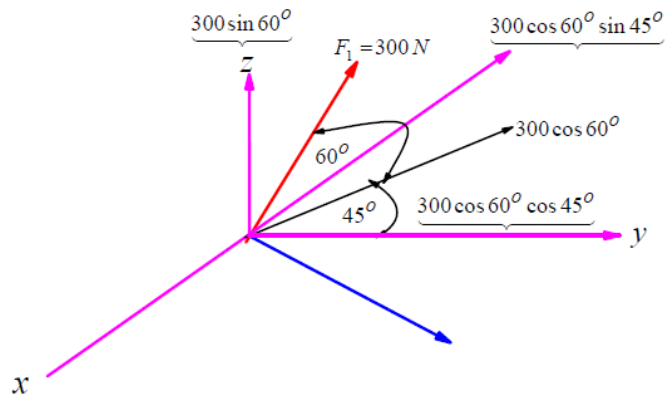

$$\vec{F}_1 = 300(-\cos 60^\circ \sin 45^\circ \vec{i} + \cos 60^\circ \cos 45^\circ \vec{j} + \sin 60^\circ \vec{k})$$

$$\vec{F}_1 = 300\left(-\left(0.5\right)\left(\frac{1}{\sqrt{2}}\right) \vec{i} + \left(0.5\right)\left(\frac{1}{\sqrt{2}}\right) \vec{j} + \frac{\sqrt{3}}{2} \vec{k}\right) \vec{F}_1 = 300\left(-\left(0.3535\right) \vec{i} + \left(0.3535\right) \vec{j} + 1.732 \vec{k}\right)$$

$$\vec{F}_1 = (-106.07) \vec{i} + 106.07 \vec{j} + 259.81 \vec{k}$$

$$\cos \alpha = -\frac{106.07}{300} = -0.3569 \quad \rightarrow \quad \alpha = \cos^{-1}(-0.3569) = 110.7056^\circ$$

$$\cos \beta = \frac{106.07}{300} = 0.3569 \quad \rightarrow \quad \beta = \cos^{-1}(0.3569) = 69.09^\circ$$

$$\cos \gamma = \frac{259.81}{300} = 0.688033 \quad \rightarrow \quad \gamma = \cos^{-1}(0.688033) = 29.99909^\circ = 30^\circ$$

**Example 10:** The chandelier is supported by three chains which are concurrent at point  $O$ . If the resultant force at  $O$  has a magnitude of  $130 \text{ lb}$  and is directed along the negative  $Z$  axis, determine the force in each chain.

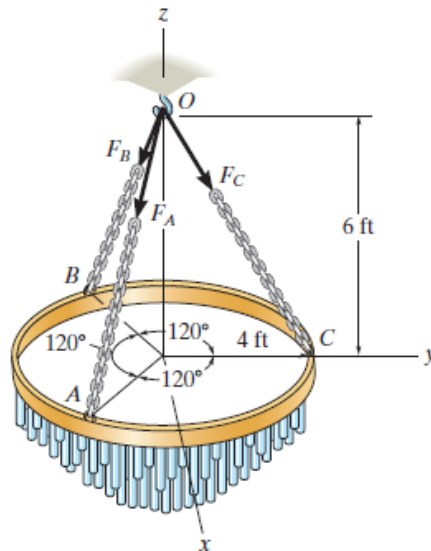

### Solution

**Equations of Equilibrium.** First we will express each force in Cartesian vector form.

Since the coordinates of points  $O$ ,  $A$ ,  $B$  and  $C$  are  $O(0, 0, 6)$ ,

Figure) we have below (see  $A(2\sqrt{3}, -2, 0)$ ,  $B(-2\sqrt{3}, -2, 0)$ ,  $C(0, 4, 0)$ )

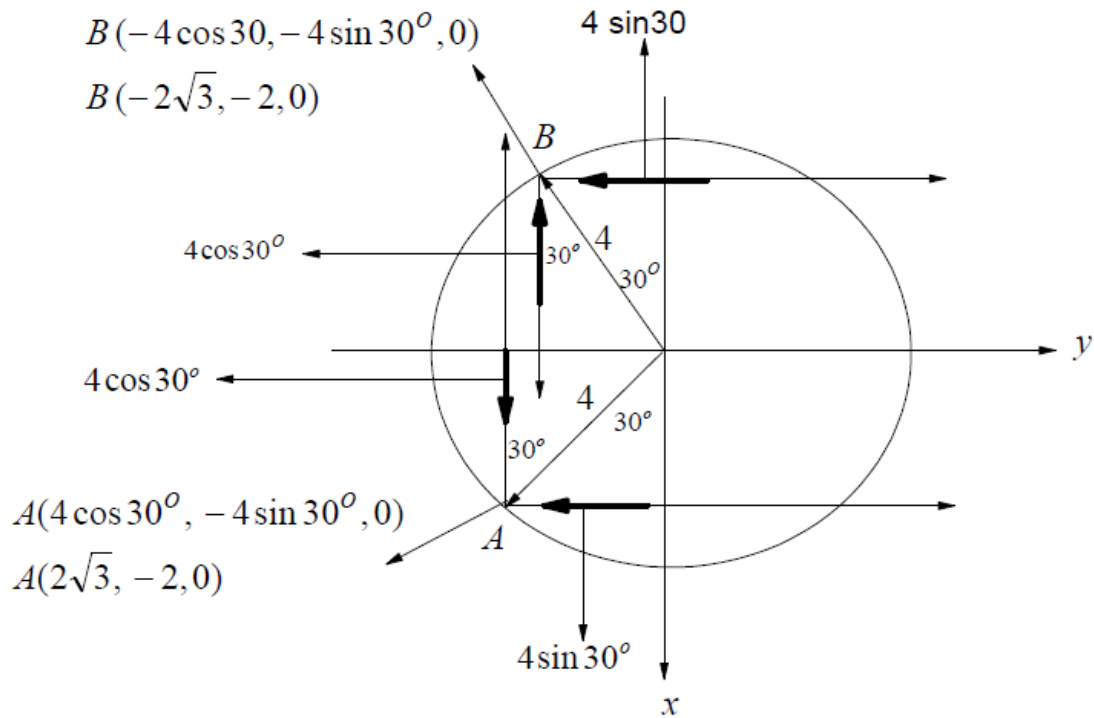

$$\vec{F}_{OA} = \frac{F_{OA}}{\sqrt{52}} (2\sqrt{3}\vec{i} - 2\vec{j} - 6\vec{k})$$

$$\vec{F}_{OB} = \frac{F_{OB}}{\sqrt{52}} (-2\sqrt{3}\vec{i} - 2\vec{j} - 6\vec{k})$$

$$\vec{F}_{OC} = \frac{F_{OC}}{\sqrt{52}} (4\vec{j} - 6\vec{k})$$

The magnitude of resultant force is, i. e.  $\vec{F}_R = \vec{F}_{OA} + \vec{F}_{OB} + \vec{F}_{OC}$

$$\vec{F}_R = 130\vec{k} = \frac{F_{OA}}{\sqrt{52}} (2\sqrt{3}\vec{i} - 2\vec{j} - 6\vec{k}) + \frac{F_{OB}}{\sqrt{52}} (-2\sqrt{3}\vec{i} - 2\vec{j} - 6\vec{k}) + \frac{F_{OC}}{\sqrt{52}} (4\vec{j} - 6\vec{k}) \quad (1)$$

From Eq. (1), we have

$$0 = \frac{F_{OA}}{\sqrt{52}} (2\sqrt{3}) + \frac{F_{OB}}{\sqrt{52}} (-2\sqrt{3}) \rightarrow F_{OA} = F_{OB} \quad (2)$$

Also, from Eq. (1), we have

$$0 = \frac{F_{OA}}{\sqrt{52}} (-2) + \frac{F_{OB}}{\sqrt{52}} (-2) + \frac{F_{OC}}{\sqrt{52}} (4) \rightarrow 0 = -F_{OA} - F_{OB} + 2F_{OC}$$

From Eq. (2), we have  $0 = -F_{OA} - F_{OA} + 2F_{OC} \rightarrow -2F_{OA} + 2F_{OC} = 0$

$$F_{OA} = F_{OC} \quad (3)$$

From Eqs. (2) and (3), we have

$$F_{OA} = F_{OB} = F_{OC} \quad (4)$$

Again, from Eq. (1), we have

$$130 = \frac{F_{OA}}{\sqrt{52}} (-6) + \frac{F_{OB}}{\sqrt{52}} (-6) + \frac{F_{OC}}{\sqrt{52}} (-6), \text{ and from Eq. (4), we have}$$

$$130 = 3 \left( \frac{F_{OA}}{\sqrt{52}} (-6) \right) \rightarrow F_{OA} = -\frac{130\sqrt{52}}{18} = -52.1 \text{ lb}$$

Then the force in each chain are  $F_{OA} = F_{OB} = F_{OC} = 52.1 \text{ lb}$



**Example: 11** Express each of the forces in Cartesian vector form and determine the magnitude and coordinate direction angles of the resultant force for the two forces act in below figure ?

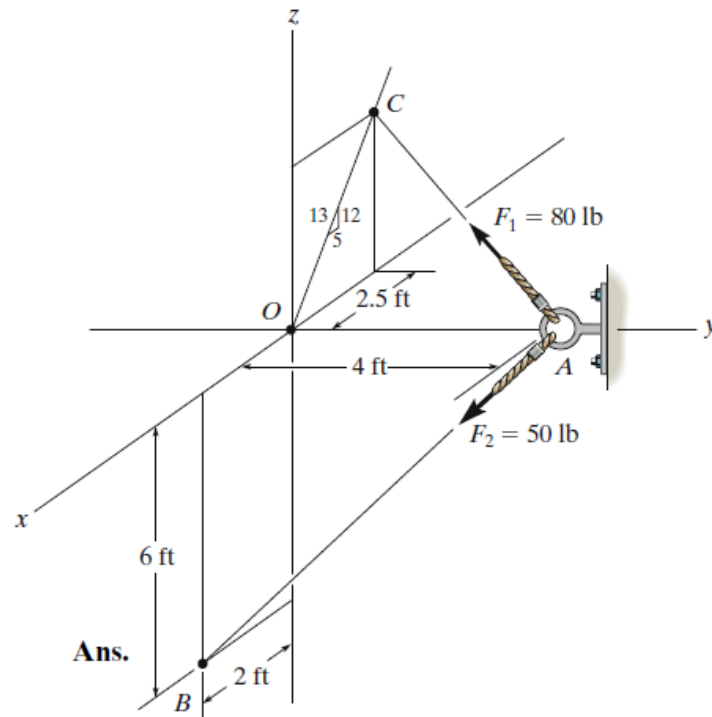

### Solution

**Equations of Equilibrium.** First we will express each force in Cartesian vector form. Since the coordinates of points  $A, B$  are given  $A(0, 4, 0), B(2, 0, -6)$

While,  $C$  is given as (see blow Figure)  $C(-2.5, 0, \frac{12}{5}(2.5)) \rightarrow C(-2.5, 0, 6)$ .

Since the force  $F_{AB}$  acts across the two points  $A(0, 4, 0)$  and  $B(2, 0, -6)$ . So the unit vector in this direction is  $\vec{e}_{AB} = \frac{1}{\sqrt{56}}(2, -4, -6)$ , i. e. Then

$$\vec{F}_{AB} = F_{AB} \vec{e}_{AB} = \frac{F_{AB}}{\sqrt{56}}(2, -4, -6) = \frac{50}{\sqrt{56}}(2, -4, -6).$$

Also, force  $F_{AC}$  acts across the two points  $A(0, 4, 0)$  and  $C(-2.5, 0, 6)$ . So the unit vector in this direction is  $\vec{e}_{AC} = \frac{1}{\sqrt{58.25}}(-2.5, -4, 6)$ , i. e. Then

$$\vec{F}_{AC} = F_{AC} \vec{e}_{AC} = \frac{F_{AC}}{\sqrt{58.25}}(2.5, -4, 6) = \frac{80}{\sqrt{58.25}}(-2.5, -4, 6)$$

$$\vec{F} = \vec{F}_{AB} + \vec{F}_{AC}$$

$$\vec{F} = \frac{50}{\sqrt{56}}(2, -4, -6) + \frac{80}{\sqrt{58.25}}(-2.5, -4, 6)$$

$$\vec{F} = \left( \frac{100}{\sqrt{56}} - \frac{200}{\sqrt{58.25}} \right) \vec{i} - \left( \frac{200}{\sqrt{56}} + \frac{320}{\sqrt{58.25}} \right) \vec{j} + \left( -\frac{300}{\sqrt{56}} + \frac{480}{\sqrt{58.25}} \right) \vec{k}$$

$$\vec{F} = \left( \frac{100}{7.4833} - \frac{200}{7.632} \right) \vec{i} - \left( \frac{200}{7.4833} + \frac{320}{7.632} \right) \vec{j} + \left( -\frac{300}{7.4833} + \frac{480}{7.632} \right) \vec{k}$$

$$\vec{F} = (13.3511 - 26.2054)\vec{i} - (26.7261 + 41.9287)\vec{j} + (-40.0892 + 62.893)\vec{k}$$

$$\vec{F} = (12.8543)\vec{i} - (68.6548)\vec{j} + (22.807)\vec{k}$$

$$\text{Then } F = \sqrt{(-12.8543)^2 + (-68.6548)^2 + (22.807)^2} = 73.5 \text{ lb}$$

$$\text{The direction of } F \text{ given from } \cos\alpha = \frac{F_x}{F}, \cos\beta = \frac{F_y}{F}, \cos\gamma = \frac{F_z}{F}$$

Then

$$\cos\alpha = -\frac{12.8543}{73.5} = -0.174049 \quad \rightarrow \quad \alpha = \cos^{-1}(0.8) = 100.0233^\circ$$

$$\cos\beta = -\frac{68.6548}{73.5} = -0.934078 \quad \rightarrow \quad \beta = \cos^{-1}(-0.934078) = 159.0798^\circ$$

$$\cos\gamma = \frac{22.807}{73.5} = 0.310299 \quad \rightarrow \quad \gamma = \cos^{-1}(0.310299) = 71.9227^\circ$$

Example: 12 The bracket is subjected to the two forces shown in below Figure.

Express each force in Cartesian vector form and then determine the resultant force Find the magnitude and coordinate direction angles of the resultant force

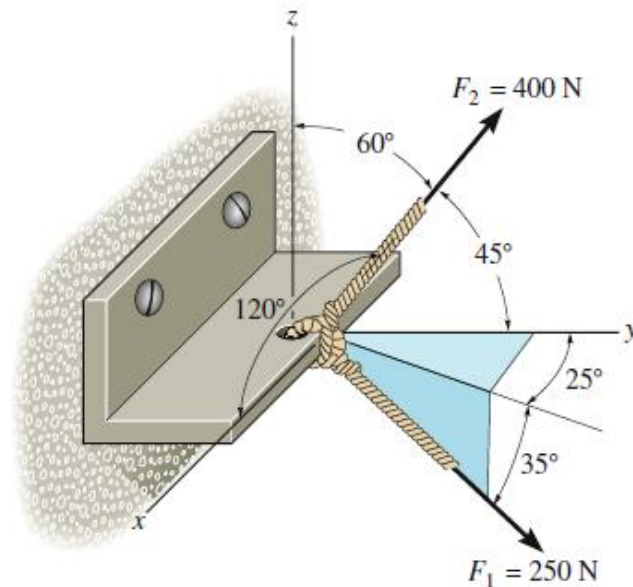

**Solution**

$$\vec{F}_1 = 250(\cos 35^\circ \sin 25^\circ \vec{i} + \cos 35^\circ \cos 25^\circ \vec{j} - \sin 35^\circ \vec{k})$$

$$\vec{F}_1 = 250(0.81915)(0.42261)\vec{i} + (0.81915)(0.9063)\vec{j} - (0.57357)\vec{k}$$

$$\vec{F}_1 = (86.545)\vec{i} + 185.5989\vec{j} - 143.394\vec{k}$$

Using the relation  $\vec{F} = F \cos\alpha \vec{i} + F \cos\beta \vec{j} + F \cos\gamma \vec{k}$ , we have

$$\vec{F}_2 = 400(\cos 120^\circ \vec{i} + \cos 45^\circ \vec{j} + \cos 60^\circ \vec{k})$$

$$\vec{F}_2 = 400\left(-0.5\vec{i} + \frac{1}{\sqrt{2}}\vec{j} + 0.5\vec{k}\right)$$

$$\vec{F}_2 = (-200\vec{i} + 282.8427\vec{j} + 200\vec{k})$$

So, the resultant given by

$$\vec{F}_R = \vec{F}_1 + \vec{F}_2 = (86.545\vec{i} + 185.5989\vec{j} - 143.394\vec{k}) + (-200\vec{i} + 282.8427\vec{j} + 200\vec{k})$$

$$\vec{F}_R = (-113.455\vec{i} + 468.44161\vec{j} + 56.606\vec{k})$$

$$F_R = \sqrt{(-113.455)^2 + (468.44161)^2 + (56.606)^2} = 485.3 \text{ N}$$

$$\cos\alpha = -\frac{113.455}{485.3} = -0.23378 \quad \rightarrow \quad \alpha = \cos^{-1}(-0.23378) = 103.5197^\circ$$

$$\cos\beta = \frac{468.44161}{485.3} = 0.96526 \quad \rightarrow \quad \beta = \cos^{-1}(0.96526) = 15.1462^\circ$$

$$\cos\gamma = \frac{56.606}{485.3} = 0.11664 \quad \rightarrow \quad \gamma = \cos^{-1}(0.11664) = 83.3017^\circ$$

## Problems

(1) Express  $F_1$ ,  $F_2$ , and  $F_3$  as Cartesian vectors.

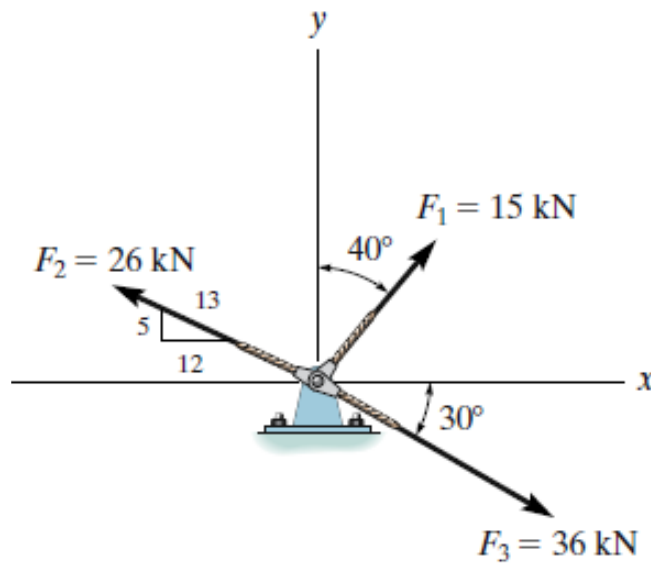

(2) Determine the magnitude of the resultant force and its orientation measured counterclockwise from the positive x axis

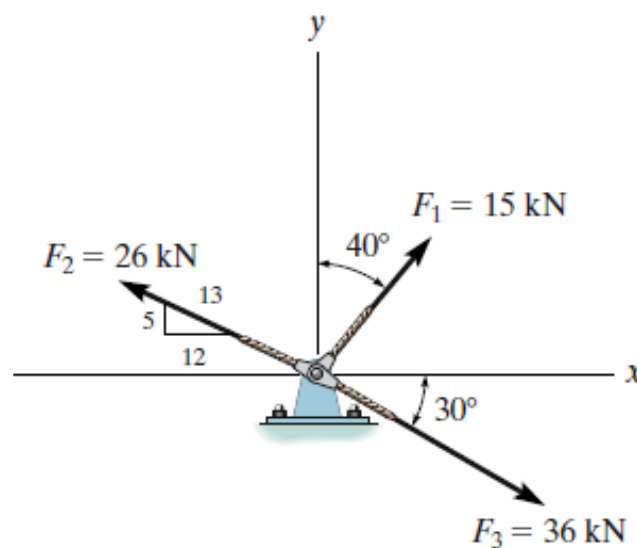

(3) Express  $F_1$  and  $F_2$  as Cartesian vectors.

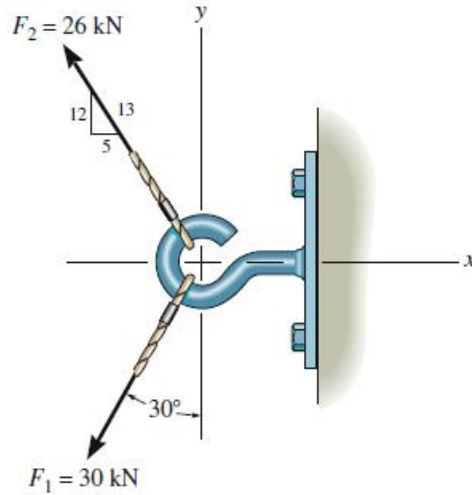

(4) Determine the magnitude of the resultant force and its direction measured counterclockwise from the positive x axis.

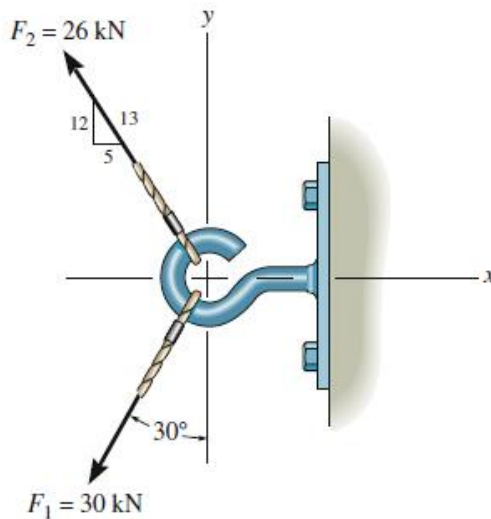

(5) Determine the magnitude and coordinate direction angles of  $F_3$  so that the resultant of the three forces acts along the positive y axis and has a magnitude of 600 lb.

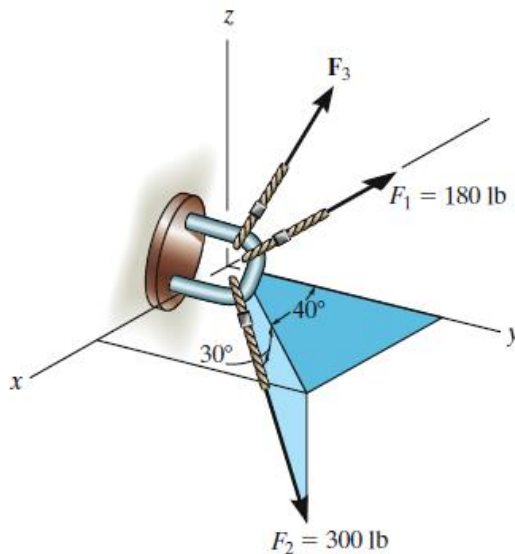

(6) Determine the magnitude and coordinate direction angles of  $F_3$  so that the resultant of the three forces is zero

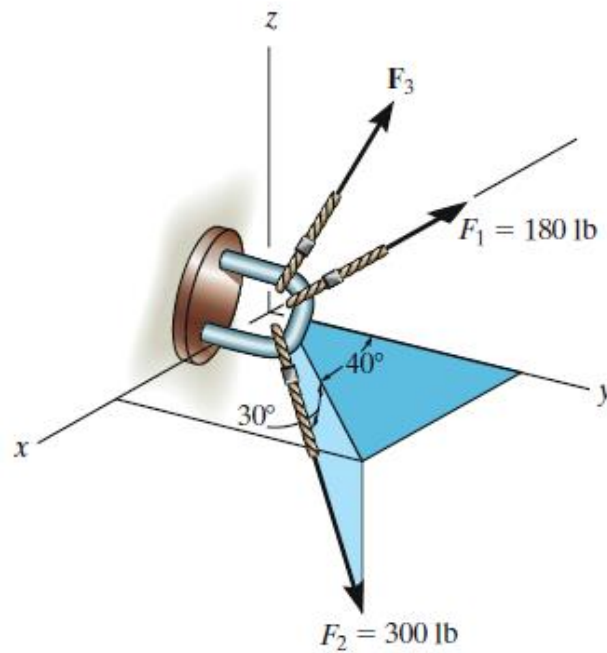

(7) The plate is suspended using the three cables which exert the forces shown. Express each force as a Cartesian vector.

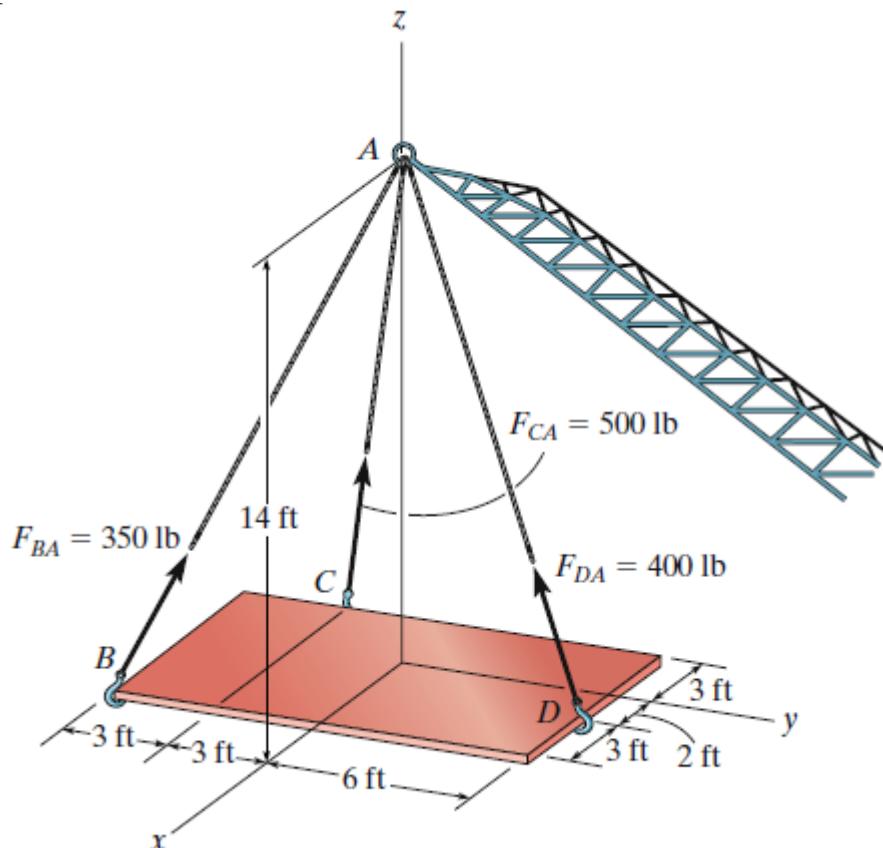

(8) Determine the magnitude and coordinates on angles of the resultant force.

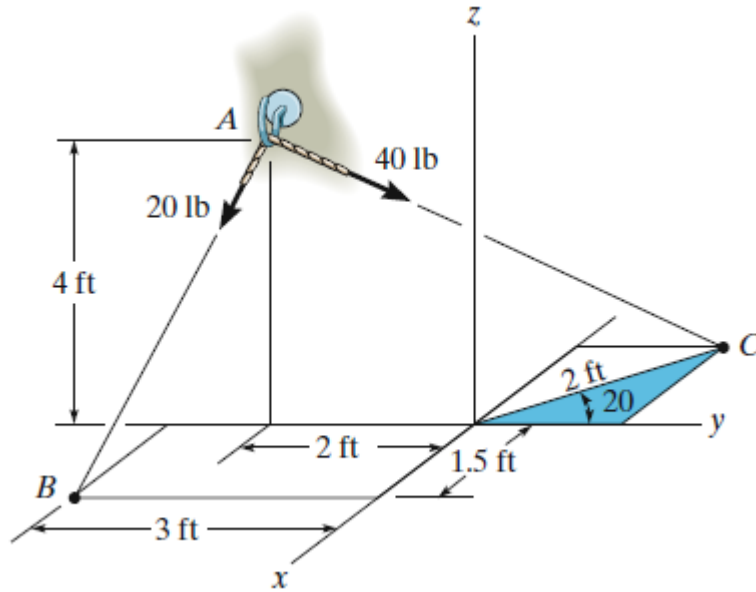

(9) Express force  $F$  in Cartesian vector form if point  $B$  is located 3 m along the rod end  $C$ .

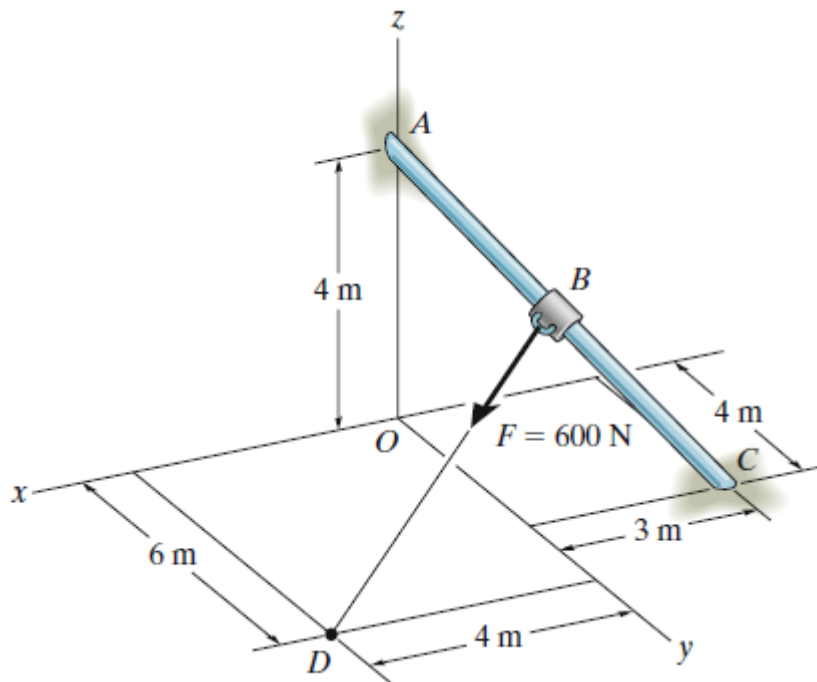

# Chapter: 3

## Condition for the Equilibrium of a particle

A particle is said to be in equilibrium if it remains at rest if originally at rest, or has a constant velocity if originally in motion. Most often, however, the term “equilibrium” or, more specifically, “static equilibrium” is used to describe an object at rest. To maintain equilibrium, it is necessary to satisfy Newton’s first law of motion, which requires the resultant force acting on a particle to be equal to zero . This condition may be stated mathematically as

$$F = 0 \quad (1)$$

where  $F$  is the vector sum of all the forces acting on the particle.

Not only is  $F = 0$  a necessary condition for equilibrium, it is also a sufficient condition.

This follows from Newton’s second law of motion, which can be written as  $F = ma$  .

Since the force system satisfies Eq. (1) , then  $ma = 0$  , and therefore the particle’s

acceleration  $a = 0$  . Consequently, the particle indeed moves with constant velocity or remains at rest.

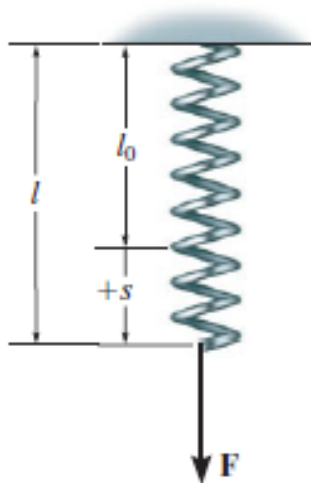

Fig. 1

### 1. Coplanar Force Systems

plane, as in Fig. (2) , then each force can be resolved into its  $\vec{i}$  and  $\vec{j}$  components. For equilibrium, these forces must sum to produce a zero

force resultant, i.e.,  $\sum F = 0 \rightarrow \sum F_x \vec{i} + \sum F_y \vec{j} = 0$

For this vector equation to be satisfied, the resultant force's x and y components must both be equal to zero. Hence,  $\sum F_x = 0$ ,  $\sum F_y = 0$

These two equations can be solved for at most two unknowns, generally represented as angles and magnitudes of forces shown on the particle's free-body diagram.

When applying each of the two equations of equilibrium, we must account for the sense of direction of any component by using an algebraic sign which corresponds to the arrowhead direction of the component along the x or y axis. It is important to note that if a force has an unknown magnitude, then the arrowhead sense of the force on the free-body diagram can be assumed. Then if the solution yields a negative scalar, this indicates that the sense of the force is opposite to that which was assumed.

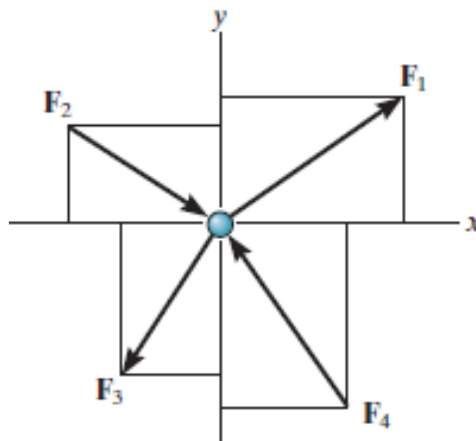
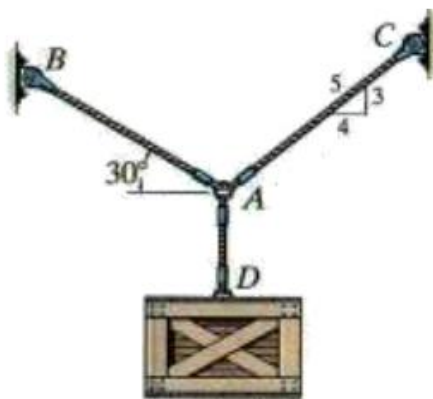

Fig. 2

**Example 1:** The Crate has a weight of  $550\text{N} (\approx 55\text{ kg})$ . Determine the tension in each supporting cable in Figure



### Solution

Applying the equations of equilibrium along the x and y axes, we have



$$\sum F_x = 0 \rightarrow T_{AC}\left(\frac{4}{5}\right) - T_{AB} \cos 30^\circ = 0 \rightarrow T_{AC}\left(\frac{4}{5}\right) - \frac{\sqrt{3}}{2} T_{AB} = 0$$

$$\sum F_y = 0 \rightarrow T_{AC}\left(\frac{3}{5}\right) + T_{AB} \sin 30^\circ - 550 = 0 \rightarrow T_{AC}\left(\frac{3}{5}\right) + \frac{1}{2} T_{AB} = 550$$

$$8 T_{AC} - 5\sqrt{3} T_{AB} = 0, \quad (1), \quad 6 T_{AC} + 5 T_{AB} = 5500 \quad (2)$$

$$T_{AC} = \frac{5500\sqrt{3}}{(8+6\sqrt{3})} = 518 \text{ N} \quad (8+6\sqrt{3})T_{AC} = 5500\sqrt{3} \rightarrow, \quad \text{Then } 6\sqrt{3}T_{AC} + 5\sqrt{3}T_{AB} = 5500\sqrt{3}$$

$$\text{In Eq. (1), we have } 8 \frac{5500\sqrt{3}}{(8+6\sqrt{3})} - 5\sqrt{3}T_{AB} = 0 \rightarrow 8 \frac{1100}{(8+6\sqrt{3})} - T_{AB} = 0,$$

$$T_{AB} = \frac{8800}{(8+6\sqrt{3})} = 478.5 \text{ N}$$

## 2. Three-dimensional force system

The necessary and sufficient condition for particle equilibrium is  $\sum F = 0$

In the case of a three-dimensional force system, as in Figure .

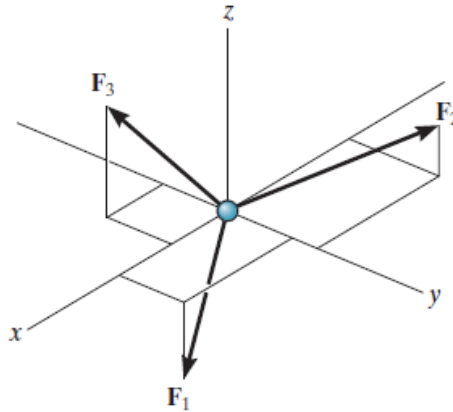

We can resolve the forces into their respective  $\vec{i}$ ,  $\vec{j}$ ,  $\vec{k}$  components, so that

$$\sum F_x \vec{i} + F_y \vec{j} + F_z \vec{k} = 0.$$

To satisfy this equation we require

$$F_x = 0, \quad F_y = 0, \quad F_z = 0$$

These three equations state that the algebraic sum of the components of all the forces acting on the particle along each of the coordinate axes must be zero. Using them we can solve for at most three unknowns, generally represented as coordinate direction angles or magnitudes of forces shown on the particle's free-body diagram.

**Example 2:** If cable  $AD$  is tightened by a turnbuckle and develops a tension of  $1300 \text{ lb}$ . Determine the tension developed in cables  $AB$  and  $AC$  and the force developed along the antenna tower  $AE$  at point  $A$ .

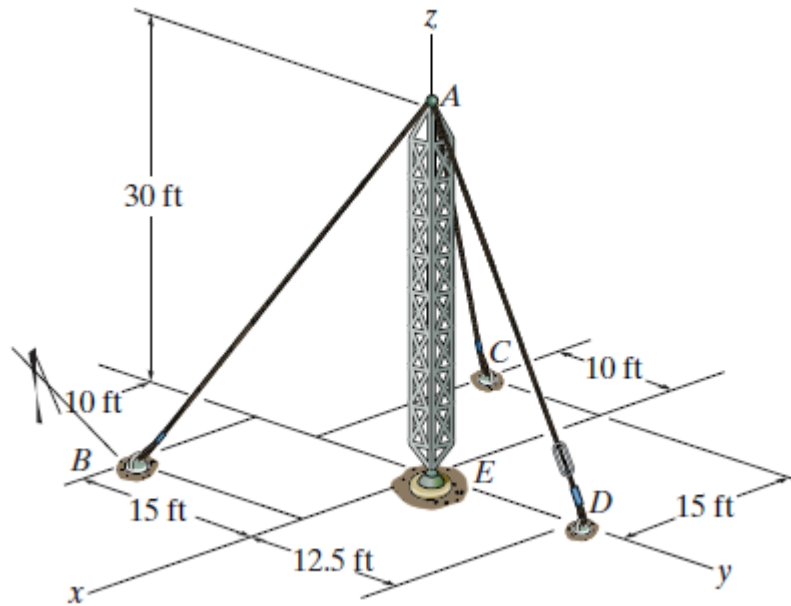

**Free-Body Diagram.** First we will express each force in Cartesian vector form. Since the coordinates of points  $O$ ,  $A$ ,  $B$  and  $C$  are (see below Figure)

$$A(0, 0, 30), \quad B(10, -15, 0), \quad C(-15, -10, 0), \quad D(0, 12.5, 0), \quad E(0, 0, 0),$$

From the Figure we can express  $T_{AB}$ ,  $T_{AC}$ ,  $T_{AD}$  and  $F$  as follows

Since the tension  $\vec{T}_{AB}$  acts across the two points  $A$  and  $B$ . So the unit vector in this

direction is  $\vec{e}_{AB} = B - A = \frac{1}{\sqrt{1225}}(10, -15, -30) = \frac{1}{35}(10, -15, -30) = \frac{1}{7}(2, -3, -6)$ , i. e

$\vec{e}_{AB} = \frac{1}{7}(2, -3, -6)$ . Then

$$\vec{T}_{AB} = T_{AB} \vec{e}_{AB} = \vec{e}_{AB} = \frac{T_{AB}}{7}(2, -3, -6).$$

Also, the tension  $\vec{T}_{AC}$  acts across the two points  $A$  and  $C$ . So the unit vector in this direction is

$$\vec{e}_{AC} = C - A = \frac{1}{\sqrt{1225}}(-15, -10, -30) = \frac{1}{35}(-15, -10, -30) = \frac{1}{7}(-3, -2, -6), \text{ i. e}$$

$\vec{e}_{AC} = \frac{1}{7}(-3, -2, -6)$ . Then

$$\vec{T}_{AC} = T_{AC} \vec{e}_{AC} = \frac{T_{AC}}{7}(-3, -2, -6)$$

A third time, the tension  $T_{AD}$  acts across the two points  $A$  and  $D$ . So the unit vector in this direction is

$$\vec{e}_{AD} = D - A = \frac{1}{\sqrt{1056.5}}(0, 12.5, -30) = \frac{1}{32.5}(0, 12.5, -30) = \frac{1}{325}(0, 125, -300),$$

i. e  $\vec{e}_{AD} = \frac{1}{13}(0, 5, -12)$ . Then

$$\vec{T}_{AD} = T_{AD} \vec{e}_{AD} = \frac{T_{AD}}{13}(0, 5, -12) = \frac{1300}{13}(0, 5, -12) = 100(0, 5, -12)$$

$$\vec{F} = F \vec{k}$$

Equations of Equilibrium: Equilibrium requires

$$\sum F = 0 \rightarrow \vec{T}_{AB} + \vec{T}_{AC} + \vec{T}_{AD} + F = 0, \text{ i. e.}$$

$$\frac{T_{AB}}{7}(2, -3, -6) + \frac{T_{AC}}{7}(-3, -2, -6) + 100(0, 5, -12) + F(0, 0, 1) = 0$$

$$\frac{T_{AB}}{7}(2) + \frac{T_{AC}}{7}(-3) + 100(0) + F(0) = 0 \rightarrow 2T_{AB} - 3T_{AC} = 0 \quad (1)$$

$$\frac{T_{AB}}{7}(-3) + \frac{T_{AC}}{7}(-2) + 100(5) + F(0) = 0 \rightarrow -3T_{AB} - 2T_{AC} + 3500 = 0 \quad (2)$$

$$\frac{T_{AB}}{7}(-6) + \frac{T_{AC}}{7}(-6) + 100(-12) + F(1) = 0 \rightarrow -6T_{AB} - 6T_{AC} - 8400 + 7F = 0 \quad (3)$$

From Eq. (1) and Eq. (2), we have

$$3\left\{2T_{AB} - 3T_{AC}\right\} + 2\left\{-3T_{AB} - 2T_{AC} + 3500\right\} = 0$$

$$3\left\{-3T_{AC}\right\} + 2\left\{-2T_{AC} + 3500\right\} = 0 \rightarrow 13T_{AC} = 7000 \rightarrow T_{AC} = 538.461 \text{ N}$$

In Eq. (1), we have

$$T_{AB} = \frac{3}{2}T_{AC} = \left(\frac{3}{2}\right)538.461 = 807.692 \text{ N} \rightarrow T_{AB} = 807.692 \text{ N}$$

While in Eq. (3), we have

$$-6(807.692) - 6(538.461) - 8400 + 7F = 0 \rightarrow 7F = 6(807.692 + 538.461) + 8400$$

$$F = 2353.845 \text{ N}$$

Final

$$T_{AB} = 807.692 \text{ N}, \quad T_{AC} = 538.461 \text{ N}, \quad F = 2353.845 \text{ N}.$$

**Example 3:** The crate has a mass of 130 kg. Determine the tension developed in each cable for equilibrium.

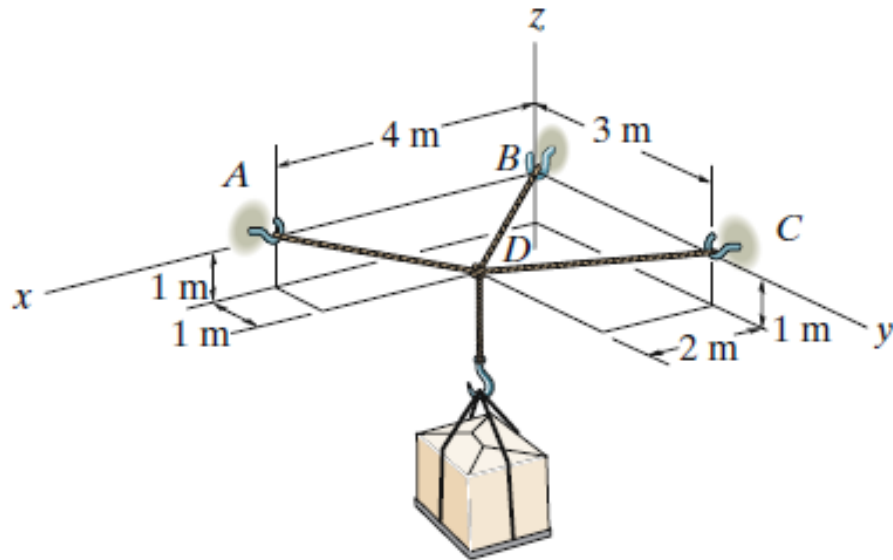

### Solution

**Free-Body Diagram.** First we will express each force in Cartesian vector form. Since

$$A(4, 0, 1), \quad B(0, 0, 1), \quad C(0, 3, 1), \quad D(2, 1, 0)$$

From the Figure we can express  $T_{AD}$ ,  $T_{BD}$ ,  $T_{CD}$  and  $F$  as follows

Since the tension  $\vec{T}_{AD}$  acts across the two points  $A$  and  $D$ . So the unit vector in this

direction is  $\vec{e}_{AD} = D - A = \frac{1}{\sqrt{6}}(-2, 1, -1)$ . Then

$$\vec{T}_{AD} = T_{AD} \vec{e}_{AD} = \vec{e}_{AD} = \frac{T_{AD}}{\sqrt{6}}(-2, 1, -1).$$

Since the tension  $\vec{T}_{BD}$  acts across the two points  $B$  and  $D$ . So the unit vector in this

direction is  $\vec{e}_{BD} = D - B = \frac{1}{\sqrt{6}}(2, 1, -1)$ . Then

$$\vec{T}_{BD} = T_{BD} \vec{e}_{BD} = \vec{e}_{BD} = \frac{T_{BD}}{\sqrt{6}}(2, 1, -1)$$

Since the tension  $\vec{T}_{CD}$  acts across the two points  $C$  and  $D$ . So the unit vector in this

direction is  $\vec{e}_{CD} = D - C = \frac{1}{\sqrt{5}}(2, 0, -1)$ . Then

$$\vec{T}_{CD} = T_{CD} \vec{e}_{CD} = \vec{e}_{CD} = \frac{T_{CD}}{\sqrt{5}}(2, 0, -1).$$

Equations of Equilibrium: Equilibrium requires

$$\sum F = 0 \rightarrow \vec{T}_{AB} + \vec{T}_{AC} + \vec{T}_{AD} + F = 0, \text{ i. e.}$$

$$\frac{T_{AB}}{7}(2, -3, -6) + \frac{T_{AC}}{7}(-3, -2, -6) + 100(0, 5, -12) + F(0, 0, 1) = 0$$

$$\frac{T_{AB}}{7}(2) + \frac{T_{AC}}{7}(-3) + 100(0) + F(0) = 0 \quad \rightarrow \quad 2T_{AB} - 3T_{AC} = 0 \quad (1)$$

$$\frac{T_{AB}}{7}(-3) + \frac{T_{AC}}{7}(-2) + 100(5) + F(0) = 0 \quad \rightarrow \quad -3T_{AB} - 2T_{AC} + 3500 = 0 \quad (2)$$

$$\frac{T_{AB}}{7}(-6) + \frac{T_{AC}}{7}(-6) + 100(-12) + F(1) = 0 \quad \rightarrow \quad -6T_{AB} - 6T_{AC} - 8400 + 7F = 0 \quad (3)$$

From Eq. (1) and Eq. (2), we have

$$3\left\{2T_{AB} - 3T_{AC}\right\} + 2\left\{-3T_{AB} - 2T_{AC} + 3500\right\} = 0$$

$$3\left\{-3T_{AC}\right\} + 2\left\{-2T_{AC} + 3500\right\} = 0 \quad \rightarrow \quad 13T_{AC} = 7000 \quad \rightarrow \quad T_{AC} = 538.461 \text{ N}$$

In Eq. (1), we have

$$T_{AB} = \frac{3}{2} T_{AC} = \left(\frac{3}{2}\right) 538.461 = 807.692 \text{ N} \quad \rightarrow \quad T_{AB} = 807.692 \text{ N}$$

While in Eq. (3), we have

$$-6(807.692) - 6(538.461) - 8400 + 7F = 0 \quad \rightarrow \quad 7F = 6(807.692 + 538.461) + 8400$$

$$F = 2353.845 \text{ N}$$

Final

$$T_{AB} = 807.692 \text{ N}, \quad T_{AC} = 538.461 \text{ N}, \quad F = 2353.845 \text{ N}.$$

**Example 4:** The 80 lb chandelier is supported by three wires as shown. Determine the force in each wire for equilibrium.

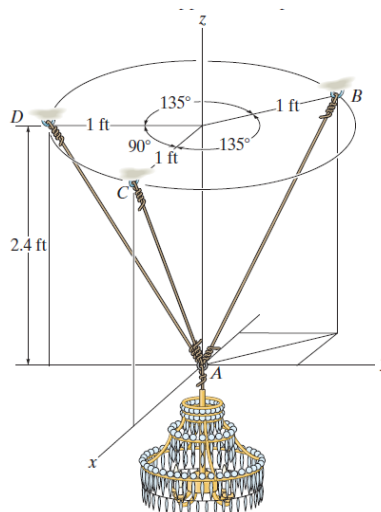

**Solution**

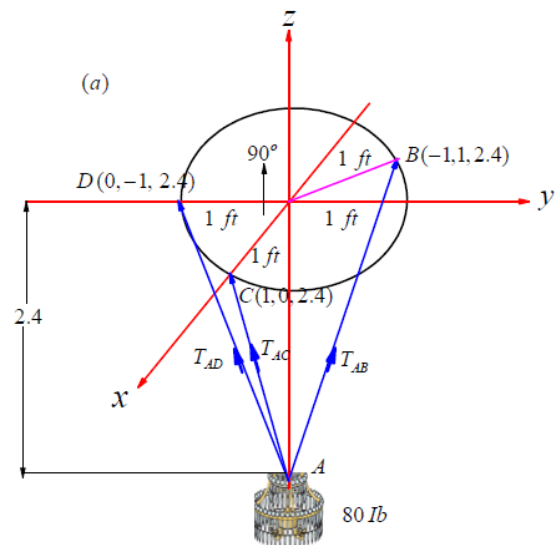

From this Figure we can organize the next three Figures (b-d)

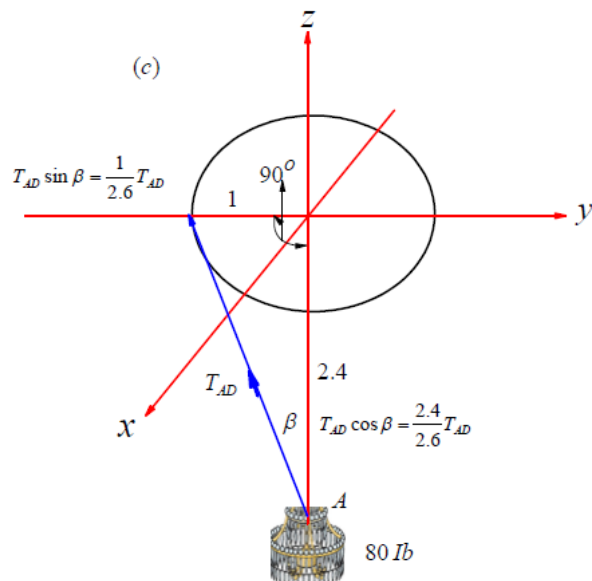
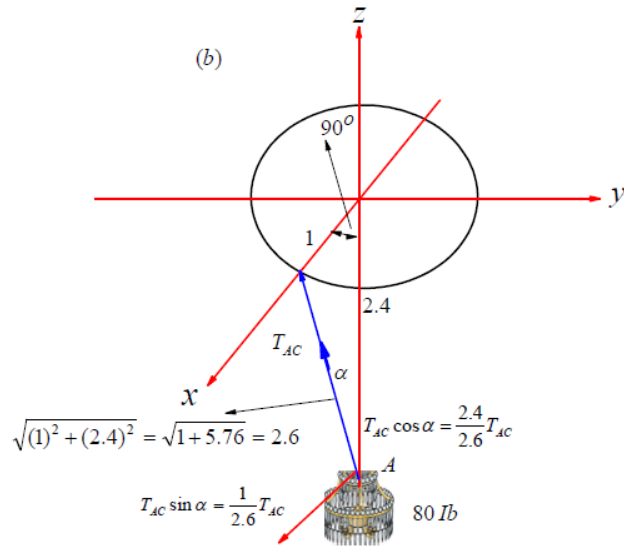

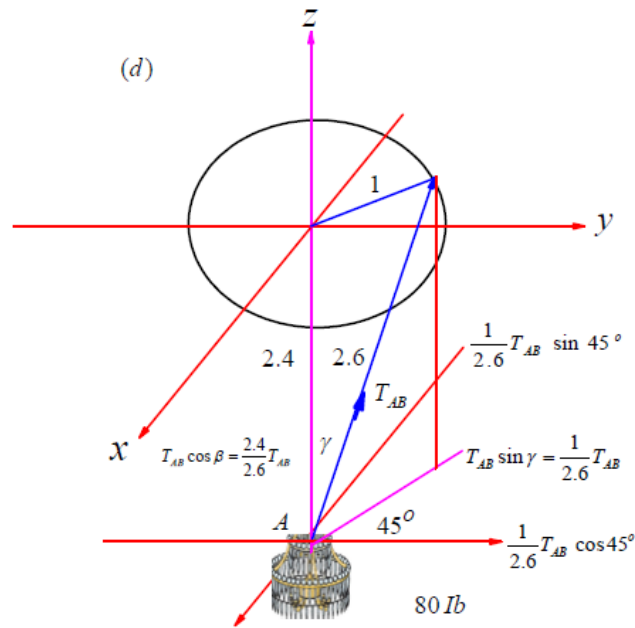

From Figure (b-d) we can find that

$$\frac{1}{2.6}T_{AC} - \frac{1}{2.6}T_{AB} \sin 45^\circ = 0 \quad \rightarrow \quad T_{AC} - 0.7071 T_{AB} = 0 \quad (1)$$

$$-\frac{1}{2.6}T_{AD} + \frac{1}{2.6}T_{AB} \sin 45^\circ = 0 \quad \rightarrow \quad T_{AD} - 0.7071 T_{AB} = 0 \quad (2)$$

$$\frac{2.4}{2.6}T_{AC} + \frac{2.4}{2.6}T_{AD} + \frac{2.4}{2.6}T_{AB} - 80 = 0 \quad \rightarrow \quad T_{AC} + T_{AD} + T_{AB} = 86.666 \quad (3)$$

Solving Eqs. (1)- (3)

Subtracting Eq. (1) and (2), we have  $T_{AC} = T_{AD}$

Then substituting into Eq. (3)

$$T_{AC} + T_{AC} + T_{AB} = 86.666 \quad \rightarrow \quad T_{AC} + \frac{1}{2}T_{AB} = 43.333 \quad (4)$$

Again substituting into Eq. (3)

$$0.7071 T_{AB} + 0.5T_{AB} = 43.333 \quad \rightarrow \quad T_{AB} = 35.9 \text{ lb}$$

Then in Eq. (4), we have  $T_{AC} + \frac{1}{2}(35.9) = 43.333 \rightarrow T_{AC} = 25.4 \text{ lb}$

Final  $T_{AB} = 35.9$ ,  $T_{AC} = T_{AD} = 25.4 \text{ lb}$  (Ans.)

**Example 5:** If each wire can sustain a maximum tension of 120 lb before it fails, determine the greatest weight of the chandelier the wires will support in the position shown.

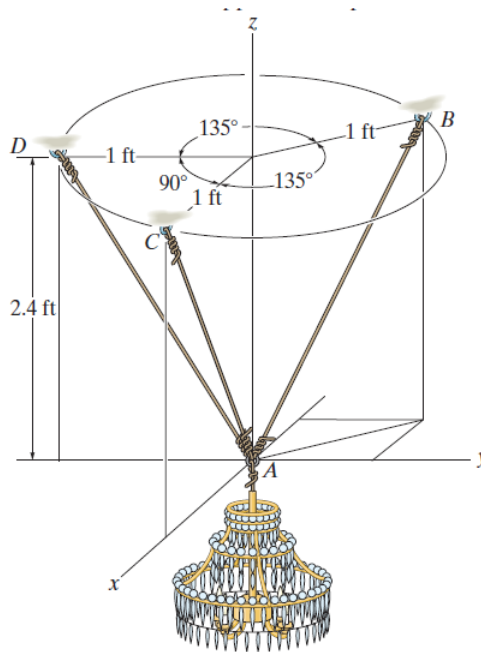

## Solution

From the above example

$$\frac{1}{2.6}T_{AC} - \frac{1}{2.6}T_{AB} \sin 45^\circ = 0 \quad \rightarrow \quad T_{AC} - 0.7071 T_{AB} = 0 \quad (1)$$

$$-\frac{1}{2.6}T_{AD} + \frac{1}{2.6}T_{AB} \sin 45^\circ = 0 \quad \rightarrow \quad T_{AD} - 0.7071 T_{AB} = 0 \quad (2)$$

$$\frac{2.4}{2.6}T_{AC} + \frac{2.4}{2.6}T_{AD} + \frac{2.4}{2.6}T_{AB} - W = 0 \quad \rightarrow \quad T_{AC} + T_{AD} + T_{AB} = 1.08 W \quad (3)$$

Now if we put  $T_{AC} = 120$  in Eq. (1), we get

$$120 - 0.7071 T_{AB} = 0 \quad \rightarrow \quad T_{AB} = \frac{120}{0.7071} = 169.7072 > 120 \quad \text{rejected solution}$$

Again, if we put  $T_{AB} = 120$  in Eq. (1), we get

$$T_{AC} - 0.7071 T_{AB} = 0 \quad \rightarrow \quad T_{AC} = 120(0.7071) = 84.85 < 120 \quad \text{A reasonable solution}$$

Then in Eq. (2), we have

$$T_{AD} - 0.7071 T_{AB} = 0 \quad \rightarrow \quad T_{AD} = (120)(0.7071) = 84.85 < 120 \quad \text{A reasonable solution}$$

In Eq. (3)

$$84.85 + 84.85 + 120 = 1.08 W \quad \rightarrow \quad 1.08 W = 289.7 \quad \rightarrow \quad W = 268.24$$

**Example 6:** The 80 lb ball is suspended from the horizontal ring using three springs each having an unstretched length of 1.5 ft and stiffness of 50 lb/ft. Determine the vertical distance  $h$  from the ring to point A for equilibrium.



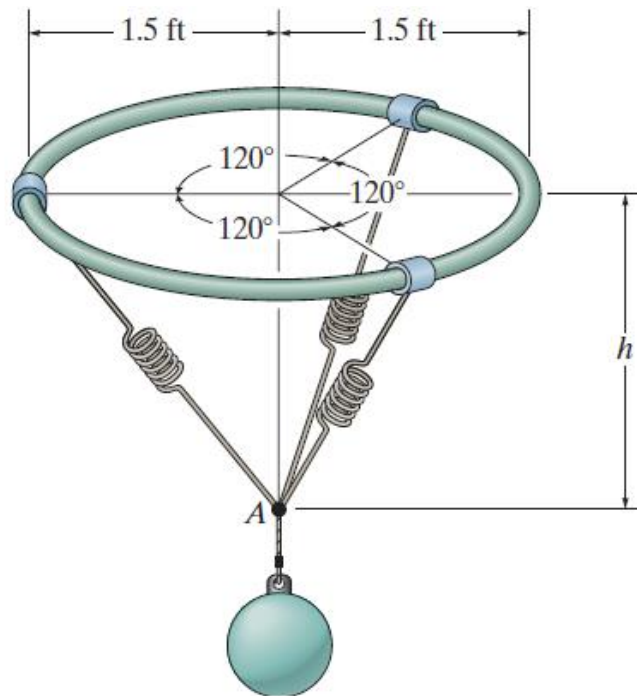

### Solution

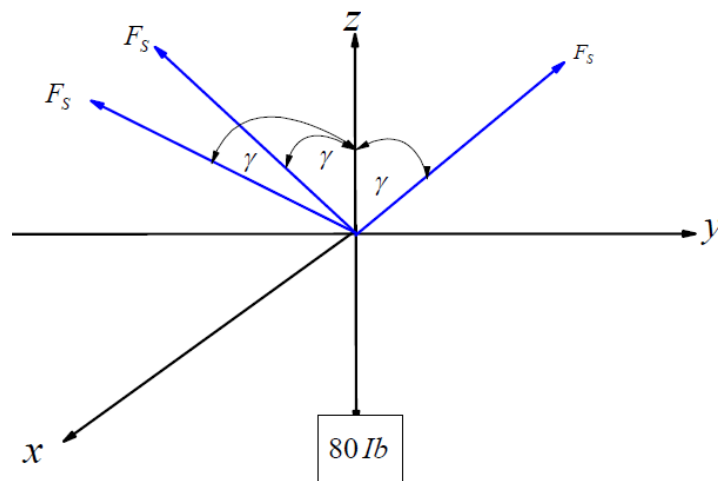

It clears that, the three springs are symmetric and subjected to a same tensile force. If one realizes this forces to the  $z$ -axis, we have

$$F_s \cos \gamma + F_s \cos \gamma + F_s \cos \gamma - 80 = 0 \quad \rightarrow \quad 3F_s \cos \gamma = 80 \quad (1)$$

But we know that , the relation between spring force and stiffness ( $k$ ) given by

$$F_s = sk = k(L - L_0) = 50 \left( \frac{1.5}{\sin \gamma} - 1.5 \right) = 75 \left( \frac{1}{\sin \gamma} - 1 \right) \quad (2)$$

Substituting from Eq. (1) into Eq. (2)

$$\frac{80}{3 \cos \gamma} = 75 \left( \frac{1}{\sin \gamma} - 1 \right) \rightarrow \frac{\sin \gamma}{\cos \gamma} \frac{80}{225} = 1 - \sin \gamma \rightarrow 0.3555 \tan \gamma + \sin \gamma = 1 \quad (3)$$

$\gamma$	$0.3555 \tan \gamma$	$\sin \gamma$	$0.3555 \tan \gamma + \sin \gamma = 1$
30	$(0.3555)(0.5773) = 0.20524$	0.5	0.70524
40	$(0.3555)(0.839) = 0.29829$	0.6427	0.9299
42	$(0.3555)(0.9) = 0.32$	0.6691	0.9891
42.5	$(0.3555)(0.916) = 0.32575$	0.67559	1.0013

Then  $\gamma = 42.5^\circ$

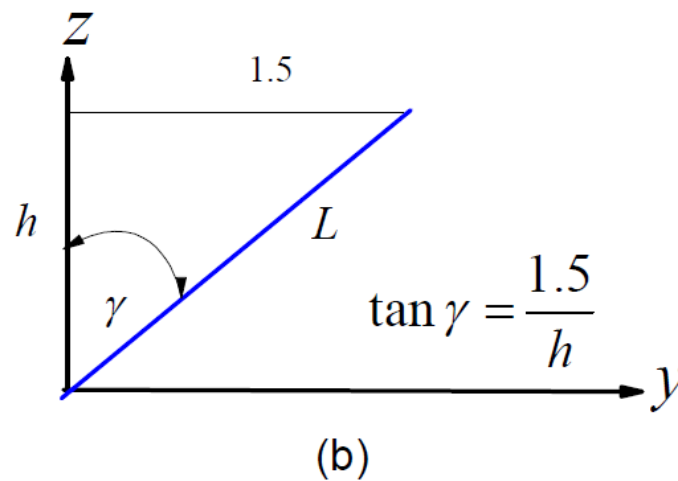

From Fig. (b) we note that

$$\tan \gamma = \frac{1.5}{h} \rightarrow h = \frac{1.5}{\tan(42.5^\circ)} = \frac{1.5}{0.916} = 1.64 \text{ ft}$$

Then, the vertical distance  $h$  from the ring to point  $A$  for equilibrium is 1.64 ft

## Problems

(1) The three cables are used to support the 40-kg flowerpot. Determine the force developed in each cable for equilibrium ?

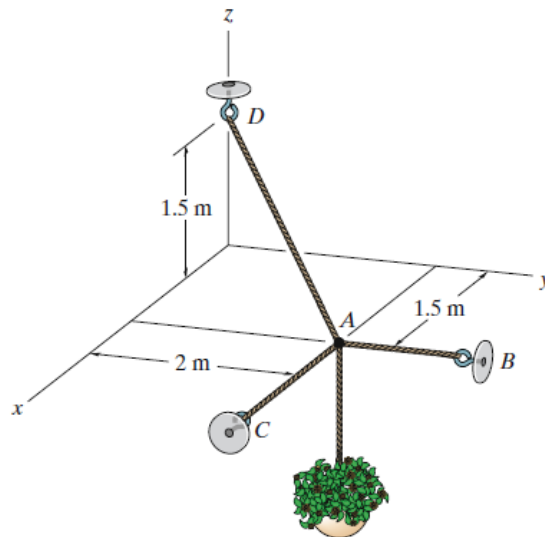

(2) The 25-kg flowerpot is supported at A by the three cords. Determine the force acting in each cord for equilibrium ?

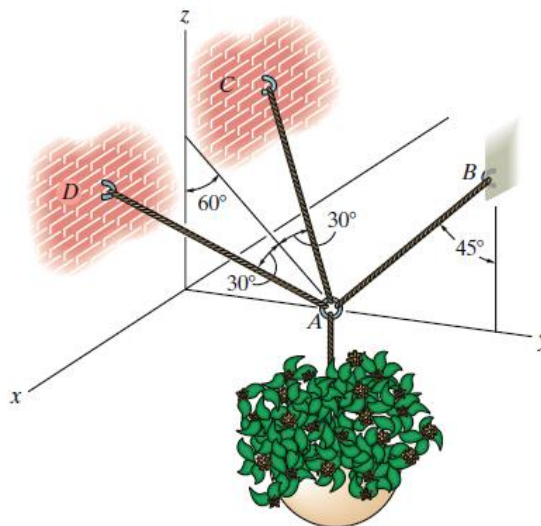

(3) If each cord can sustain a maximum tension of 50 N before it fails, determine the greatest weight of the flowerpot the cords can support ?

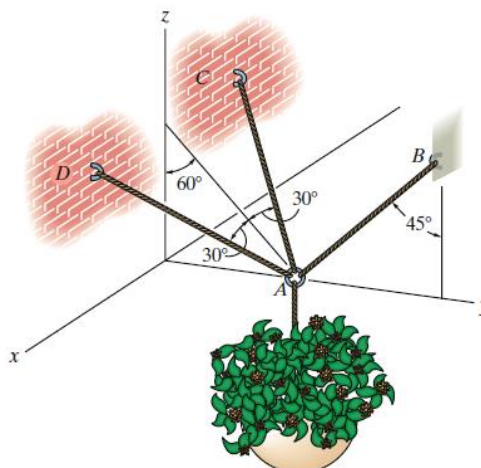

(4) If the maximum force in each rod can not exceed 1500 N, determine the greatest mass of the crate that can be supported.

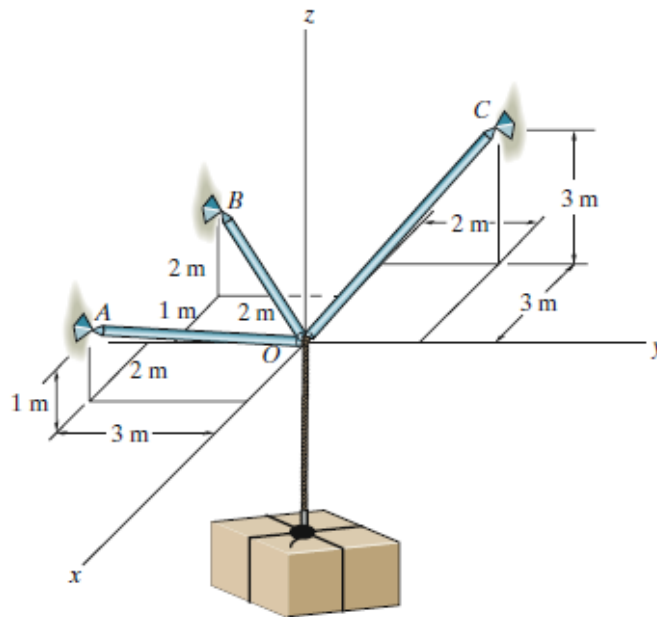

(5) If the tension developed in either cable AB or AC cannot exceed 1000 lb, determine the maximum tension that can be developed in cable AD when it is tightened by the turnbuckle. Also, what is the force developed along the antenna tower at point A ?

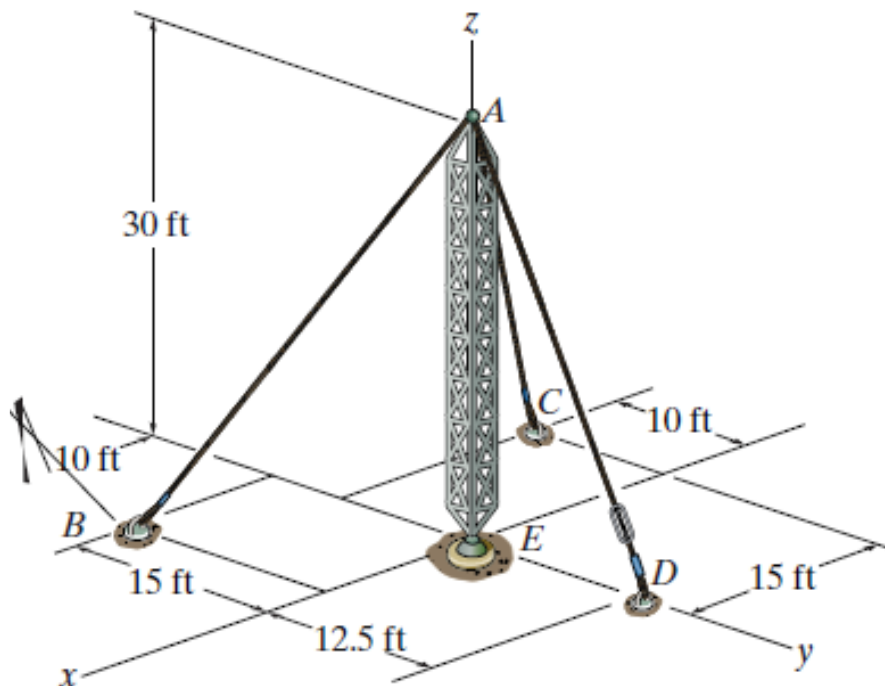

(6) Determine the tension developed in cables AB, AC and AD required for equilibrium of the 300-lb crate.

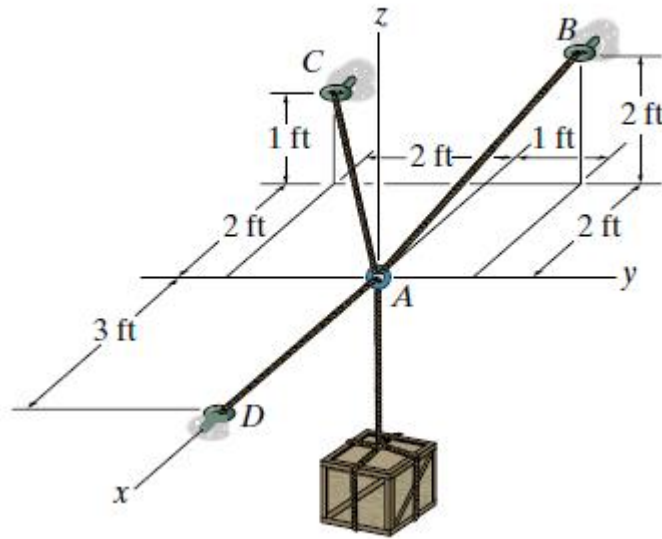

(7) Determine the maximum weight of the crate so that the tension developed in any cable does not exceed 450 lb.

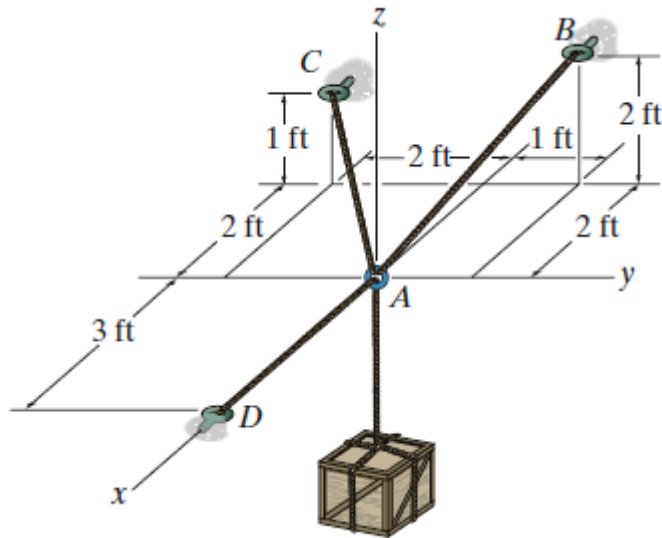

# Chapter 4

## Friction

### Introduction

If a body lies on the rough horizontal plane and is pushed by force, the plane (floor) opposes the possible motion by providing a distributed reaction force. The component of this reaction force parallel to the floor is the distributed friction force  $F_f$ , and the component normal to the floor is the distributed normal force  $N_f = R$ .

Friction is the contact resistance exerted by one body when the second body moves or tends to move past the first body. Friction is a retarding force that always acts opposite to the motion or to the tendency to move.

### Types of Friction

#### Dry Friction

Dry friction, also called Coulomb friction, occurs when un-lubricated surfaces of two solids are in contact and slide or tend to slide from each other. If lubricant separates these two surfaces, the friction created is called lubricated friction. This section will deal only with dry friction.

#### Fluid Friction

Fluid friction occurs when layers of two viscous fluids moves at different velocities. The relative velocity between layers causes frictional forces between fluid elements, thus, no fluid friction occurs when there is no relative velocity.

#### Skin friction

Skin friction also called friction drag is a component of the force resisting the motion of a solid body through a fluid.

#### Internal Friction

Internal friction is associated with shear deformation of the solid materials subjected to cyclical loading. As deformation undergo during loading, internal friction may accompany this deformation.

#### Angle of Friction

Angle of friction is defined as the angle made by the resultant of frictional force and the normal reaction with the normal reaction.

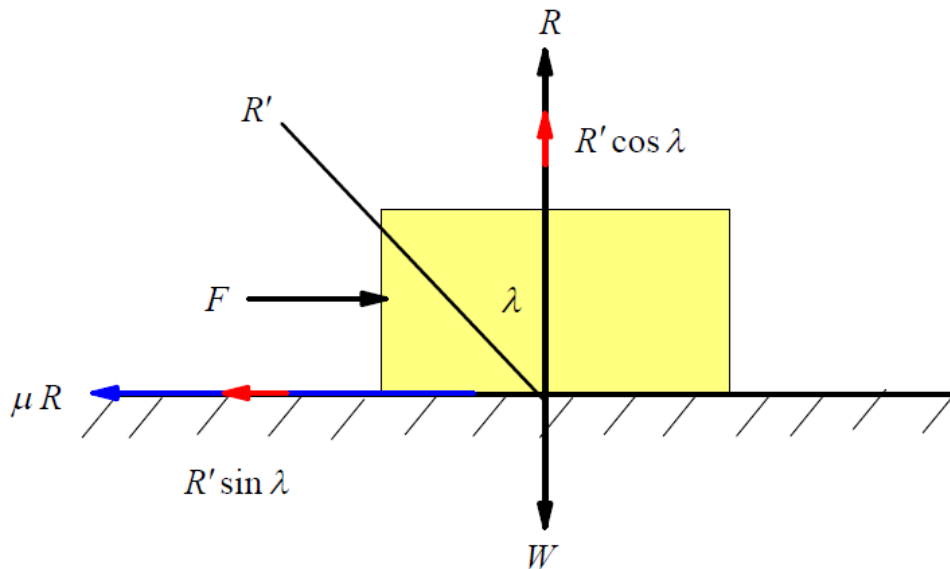

From the Figure

$$R = R' \cos \lambda, \quad \mu R = R' \sin \lambda \quad \rightarrow \quad \frac{\mu R}{R} = \frac{R' \sin \lambda}{R' \cos \lambda} \quad \rightarrow \quad \mu = \tan \lambda$$

*Example:1 Determine the minimum force required to move a block on a rough horizontal plane?*

### Solution

We draw free body diagram as shown

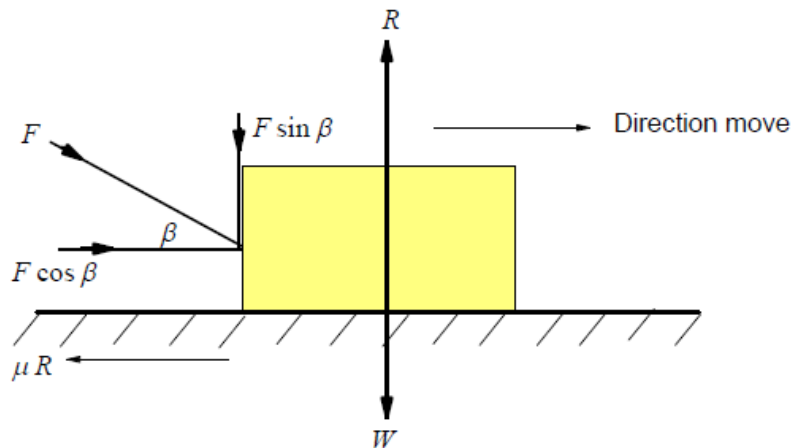

When the body is impending move, we get

$$\sum F_x = 0 \quad \rightarrow \quad R = W + F \sin \beta \quad (1)$$

$$\sum F_y = 0 \quad \rightarrow \quad \mu R = F \cos \beta \quad (2)$$

From Eq. (1) into Eq. (2), we have

$$\mu(W + F \sin \beta) = F \cos \beta \quad \rightarrow \quad \mu W = F(\cos \beta - \mu \sin \beta) \quad \rightarrow \quad F = \frac{\mu W}{\cos \beta - \mu \sin \beta} \quad (3) \text{ But}$$

$\mu = \tan \lambda$ , then Eq. (3)

$$F = \frac{\mu W}{\cos \beta - \mu \sin \beta} = \frac{W \tan \lambda}{\cos \beta - \sin \beta \tan \lambda} = \frac{W \frac{\sin \lambda}{\cos \lambda}}{\cos \beta - \sin \beta \frac{\sin \lambda}{\cos \lambda}} = \frac{W \sin \lambda}{\cos \lambda \cos \beta - \sin \beta \sin \lambda}$$

$F = \frac{W \sin \lambda}{\cos(\lambda + \beta)}$ . The value of  $F$  is minimum if the denominator is maximum. The

denominator is maximum, if  $\cos(\lambda + \beta) = 1$ .

So the minimum force required to move block on a rough horizontal plane is

$$F_{\min} = W \sin \lambda$$

*Example:2 Determining the minimum force required to move a block upward on a rough inclined plane ?*

### Solution

We draw free body diagram as shown

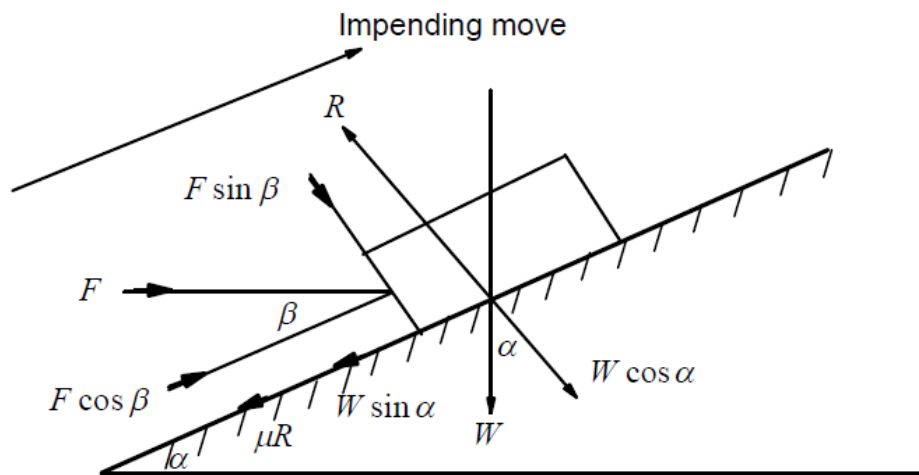

When the body is impending move, we get

$$\sum F_x = 0 \rightarrow R = W \cos \alpha + F \sin \beta \quad (1)$$

$$\sum F_y = 0 \rightarrow F \cos \beta = \mu R + W \sin \alpha \quad (2)$$

From Eq. (1) into Eq. (2), we have

$$F \cos \beta = \mu(W \cos \alpha + F \sin \beta) + W \sin \alpha$$

$$F(\cos \beta - \mu \sin \beta) = \mu W \cos \alpha + W \sin \alpha \rightarrow F = \frac{\mu W \cos \alpha + W \sin \alpha}{\cos \beta - \mu \sin \beta} \quad (3)$$

But  $\mu = \tan \lambda$ , then Eq. (3)

$$F = \frac{W \cos \alpha \tan \lambda + W \sin \alpha}{\cos \beta - \sin \beta \tan \lambda} = \frac{W \cos \alpha \frac{\sin \lambda}{\cos \lambda} + W \sin \alpha}{\cos \beta - \sin \beta \frac{\sin \lambda}{\cos \lambda}} = \frac{W(\cos \alpha \sin \lambda + \sin \alpha \cos \lambda)}{\cos \beta \cos \lambda - \sin \beta \sin \lambda}$$

$F = \frac{W \sin(\alpha + \lambda)}{\cos(\beta + \lambda)}$ . The value of  $F$  is minimum if the denominator is maximum. The

denominator is maximum, if  $\cos(\beta + \lambda) = 1$ .

So the minimum force required to move block on a rough horizontal plane is

$$F_{\min} = W \sin(\alpha + \lambda)$$



Example:3 A uniform ladder has a  $800\text{ N}$  and length  $7\text{ m}$  rests on a horizontal ground and leans against a smooth vertical wall. The angle made by ladder with the horizontal is  $60^\circ$ . When a man of weight  $600\text{ N}$  stands on the ladder  $4\text{ m}$  from the top of the ladder, the ladder is at the point of slipping. Determine the coefficient of friction between the ladder and floor?

### Solution

We draw free body diagram as shown and apply equilibrium conditions

*Motion impending:*

$$\sum F_y = 0 \rightarrow R_1 = 600 + 800 = 1400 \quad (1)$$

$$R_2 = \mu_1 R_1 = 1400\mu_1 \quad \sum F_x = 0 \rightarrow \quad (2)$$

$$\sum M_C = 0 \rightarrow R_1(AB) - \mu_1 R_1(CA) - 600(A'E' = AE) - 800(A'D' = AD) = 0$$

$$R_1(AB) - \mu_1 R_1(CA) - 600(AB - EB) - 800(AB - DB) = 0 \quad (3)$$

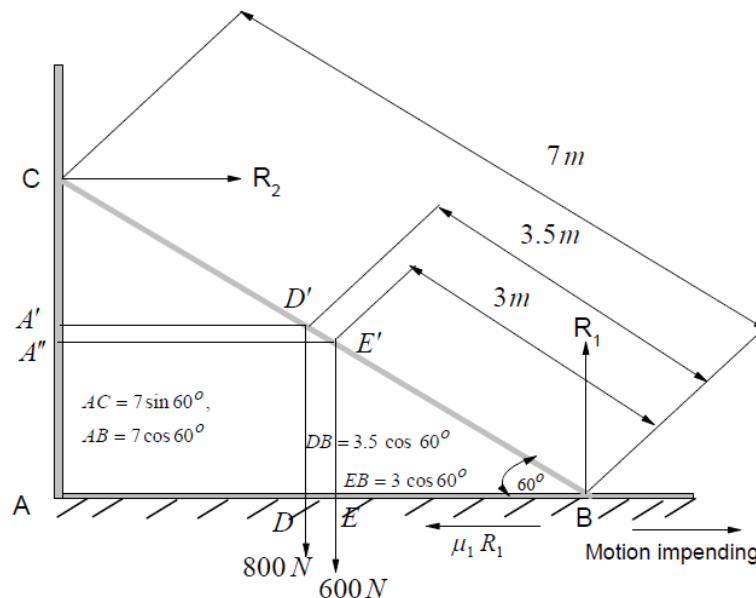

$$R_1(7 \cos 60^\circ) - \mu_1 R_1(7 \sin 60^\circ) - 600(7 \cos 60^\circ - 3 \cos 60^\circ) - 800(7 \cos 60^\circ - 3.5 \cos 60^\circ) = 0$$

$$(1400)(7 \cos 60^\circ) - (1400)\mu_1(7 \sin 60^\circ) - 600(4 \cos 60^\circ) - 800(3.5 \cos 60^\circ) = 0$$

$$(1400)(7) - (1400)\mu_1(7 \tan 60^\circ) - 600(4) - 800(3.5) = 0$$

$$\mu_1 = \frac{(1400)(7) - 600(4) - 800(3.5)}{(1400)(7 \tan 60^\circ)} = \frac{9200 - 2400 - 2800}{(9200)(1.732)} = \frac{4000}{15934.987} = 0.251$$

Other Solution  $\sum M_B = 0 \rightarrow R_2(CA) - 800(DB) - 600(EB) = 0$

$$1400\mu_1(7)(\sin 60^\circ) - 800(3.5)(\cos 60^\circ) - 600(3)(\cos 60^\circ) = 0$$

$$1400(6.063)\mu_1 - 400(3.5) - 300(3) = 0 \quad 1400(6.063)\mu_1 - 800(3.5)(0.5) - 600(3)(0.5) = 0 \rightarrow$$

$$14(6.063)\mu_1 - 4(3.5) - 3(3) = 0 \rightarrow 14(6.063)\mu_1 = 14 + 9 \rightarrow \mu_1 = \frac{23}{14(6.063)} = 0.27$$

Example:4 A uniform ladder whose weight is  $400\text{ N}$  and whose length is  $5\text{ m}$  rests on a horizontal ground and leans against a smooth (frictionless) vertical wall. If the coefficient of friction between the ladder and floor is  $0.46$ . What is the greatest distance can be placed from the base of the wall without the ladder immediately slipping?

### Solution

We draw free body diagram as shown and apply equilibrium conditions

Motion impending:

$$\sum F_x = 0 \rightarrow R_2 = \mu_1 R_1 \quad (1)$$

$$\sum F_y = 0 \rightarrow (2)$$

$$W = R_1$$

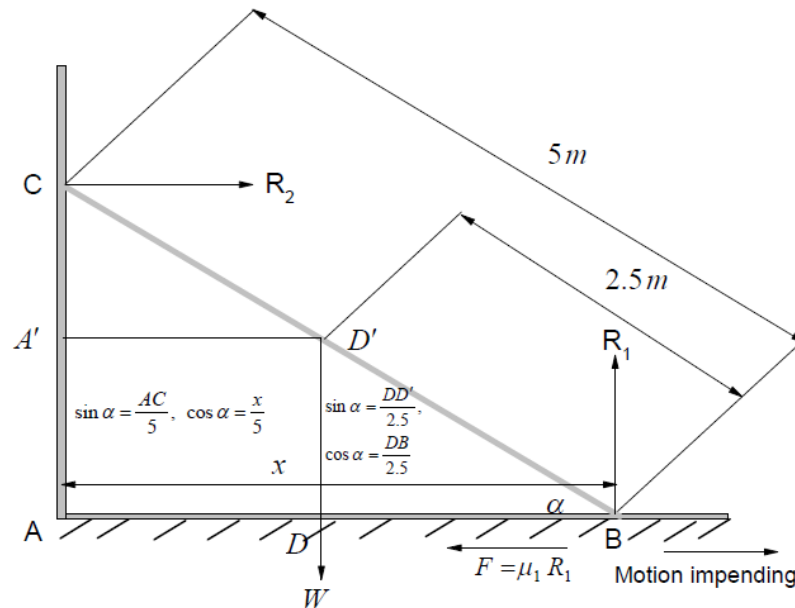

From Eqs. (1) and (2), we get

$$R_2 = \mu_1 W \rightarrow \mu_1 = \frac{R_2}{W} \quad (3)$$

$$\sum M_B = 0 \rightarrow R_2(CA) - W(DB) = 0$$

$$R_2(5\sin\alpha) - W(2.5\cos\alpha) = 0$$

$$\frac{R_2}{W} = \frac{2.5 \cos\alpha}{5 \sin\alpha} \quad (4)$$

Substitution from Eq. (4) into Eq. (3), we get

$$\mu_1 = \frac{2.5}{5} \cot\alpha \rightarrow 0.46 = \frac{2.5}{5} \frac{x}{Ac} \rightarrow 0.46 = \frac{2.5}{5} \frac{x}{\sqrt{(5)^2 - x^2}}$$

$$(0.46)(5)\sqrt{25 - x^2} = 2.5x \rightarrow (25)(0.2116)(25 - x^2) = 6.25x^2$$

$$25 - x^2 = 1.1815x^2 \rightarrow 2.1815x^2 = 25 \rightarrow x^2 = 11.46, \text{ then } x = 3.4\text{ m}$$

## Exercises

Exercise:1 A uniform ladder whose weight is  $W$  and whose length is  $L$  rests on a horizontal ground and leans against a smooth vertical wall. If the coefficient of friction between the ladder and floor is 0.46. What is the greatest distance can be placed from the base of the wall without the ladder immediately slipping?

Exercise:2 A ladder 6 m long has a mass of 18 kg and its center of gravity is 2.4 m from the bottom. The ladder is placed against a vertical wall so that it makes an angle of  $60^\circ$  with the ground. How far up the ladder can a 72-kg man climb before the ladder is on the verge of slipping? The angle of friction at all contact surfaces is  $15^\circ$

Exercise:3 The 180-lb man climbs up the ladder and stops at the position shown after he senses that the ladder is on the verge of slipping. Determine the inclination of the ladder if the coefficient of static friction between the friction pad A and the ground is . Assume the wall at B is smooth. The center of gravity for the man is at G. Neglect the weight of the ladder.

Exercise:4 The uniform 20-lb ladder rests on the rough floor or which the coefficient of static friction is and against the smooth wall at B. Determine the horizontal force  $P$  the man must exert on the ladder in order to cause it to move.

## Slipping and Tipping

Imagine a box sitting on a rough surface as shown in the figure below. Now imagine that we start pushing on the side of the box. Initially the friction force will resist the pushing force and box will sit still. As we increase the force pushing the box however, one of two things will occur.

The pushing force will exceed the maximum static friction force and the box will begin to slide across the surface (slipping).

Or, the pushing force and the friction force will create a strong enough couple that the box will rotate and fall on it's side (tipping).

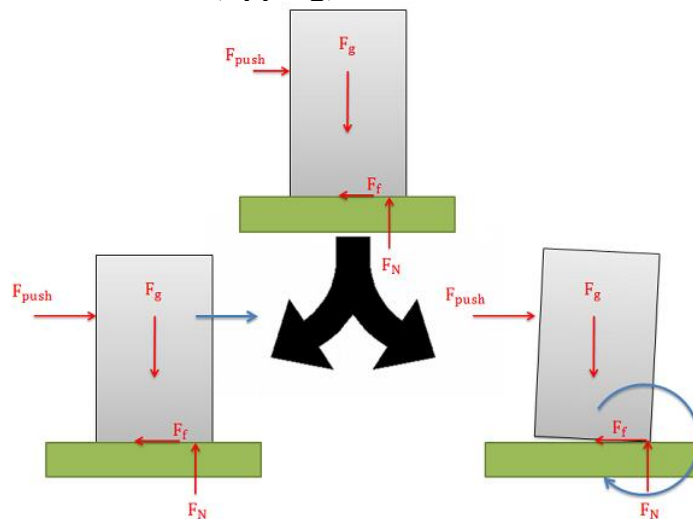

When we look at cases where either slipping or tipping may occur, we are usually interested in finding which of the two options will occur first. To determine this, we usually determine both the pushing force necessary to make the body slide and the pushing force necessary to make the body tip over. Whichever option requires less force is the option that will occur first.

### Determining the Force Required to Make an Object "Slip":

A body will slide across a surface if the pushing force exceeds the maximum static friction force that can exist between the two surfaces in contact. As is all dry friction problems, this limit to the friction force is equal to the static coefficient of friction times the normal force between the body. If the pushing force exceeds this value then the body will slip.

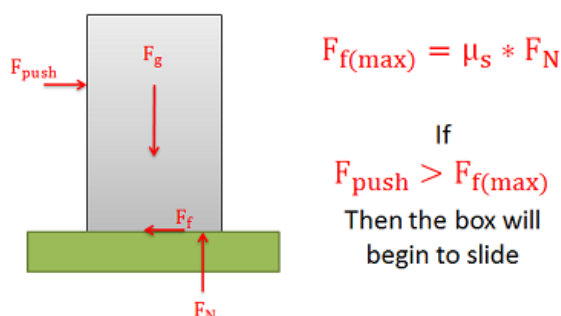

## Determining the Force Required to Make an Object "Tip":

The normal forces supporting bodies are distributed forces. These forces will not only prevent the body from accelerating into the ground due to gravitational forces, but they can also redistribute themselves to prevent a body rotating when forces cause a moment to act on the body. This redistribution will result in the equivalent point load for the normal force shifting to one side or the other. A body will tip over when the normal force can no longer redistribute itself to any further to resist the moment exerted by other forces (such as the pushing force and the friction force).

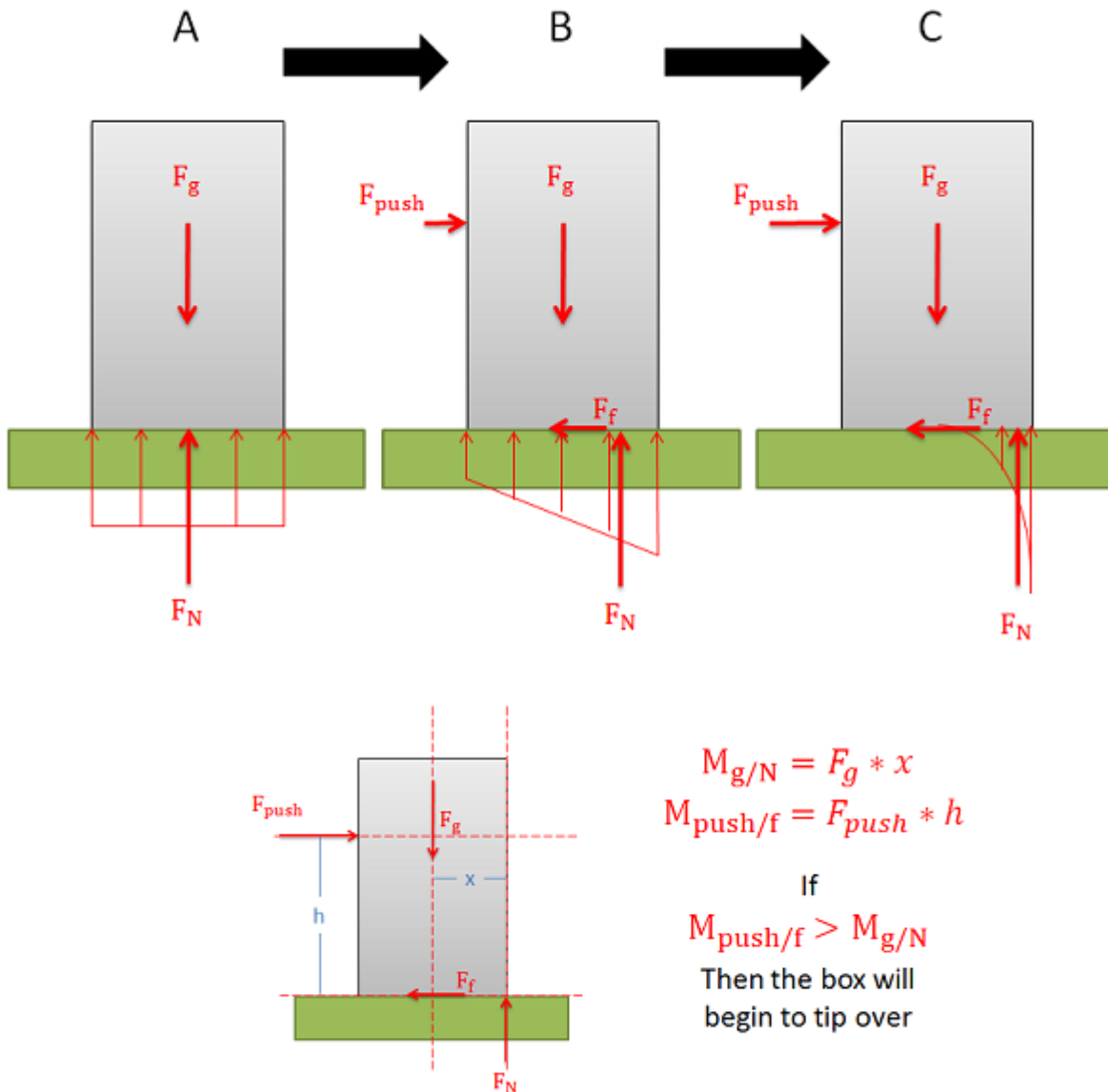

The easiest way to think about the shifting normal force and tipping is to imagine the equivalent point load of the distributed normal force. As we push or pull on the body, the normal force will shift to the left or right. This normal force and the gravitational force create a couple that exerts a moment. This moment will be countering the moment exerted by the couple formed by the pushing force and the friction force.

Because the normal force is the direct result of physical contact, we cannot shift the normal force beyond the surfaces in contact (aka the edge of the box). If countering the moment exerted by the pushing force and the friction force requires shifting the normal

force beyond the edge of the box, then the normal force and the gravity force will not be able to counter the moment and as a result the box will begin to rotate (aka tip over).

### Example:1:

The box shown below is pushed as shown. If we keep increasing the pushing force, will the box first begin to slip or will it tip over?

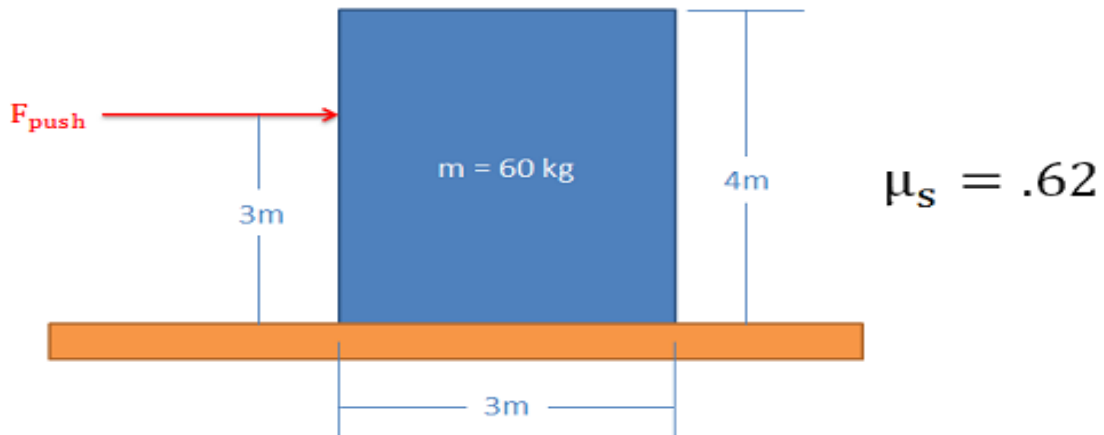

### Solution

We draw free body diagram as shown and apply equilibrium conditions

#### Slipping Case

Slipping case

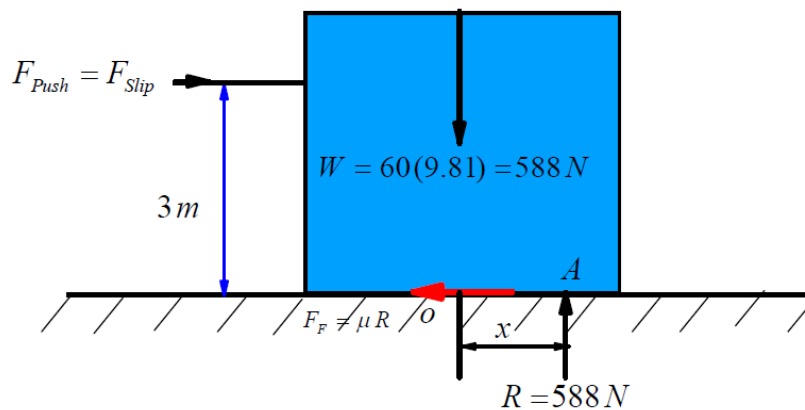

$$F_{Push} = F_{Slip} = F_F = \mu R = (0.66)(588) \rightarrow F_{Push} = F_{Slip} = 364.56 \text{ N} \quad (1)$$

#### Tipping Case

The moment at pint A

$$F_{Push}(3) = (588)(1.5) \rightarrow F_{Push} = F_{Tip} = \frac{588(1.5)}{3} = 294.56 \text{ N} \quad (2)$$

From Eqs. (1) and (2), we note that  $F_{Tip} = 294.56\text{ N} < F_{Slip} = 364.56\text{ N}$ .  
 So the box will tipping first.

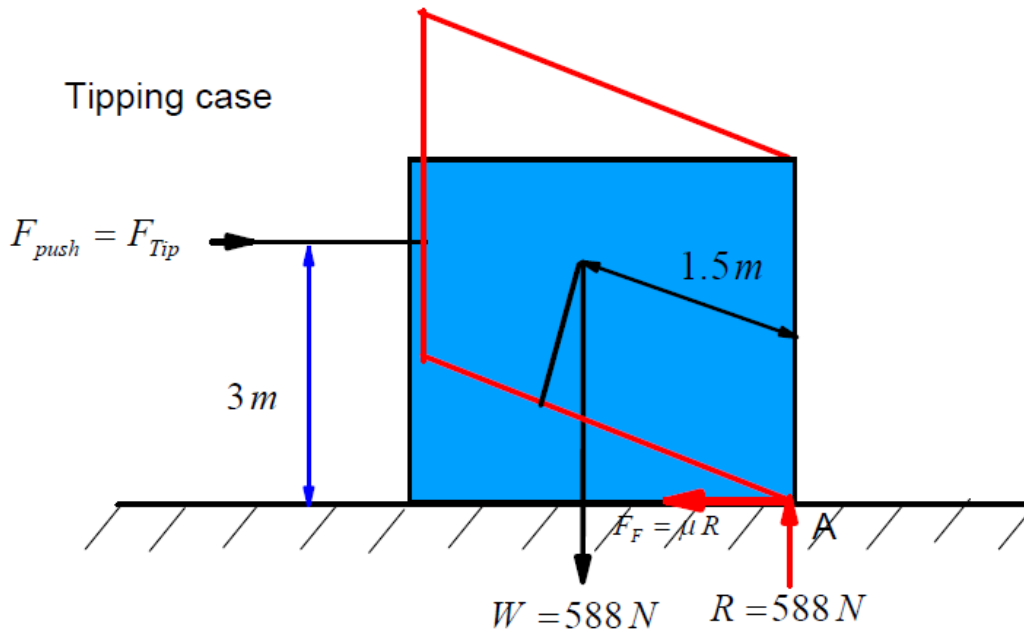

Check  $\sum M_A = 0 \rightarrow 364.56(3) - 588(x) = 0 \rightarrow x = 1.86 > 1.5$

Not Slipping

Example: 2: What is the maximum value of  $d$  that will allow the box to slipping along the surface before tipping over?

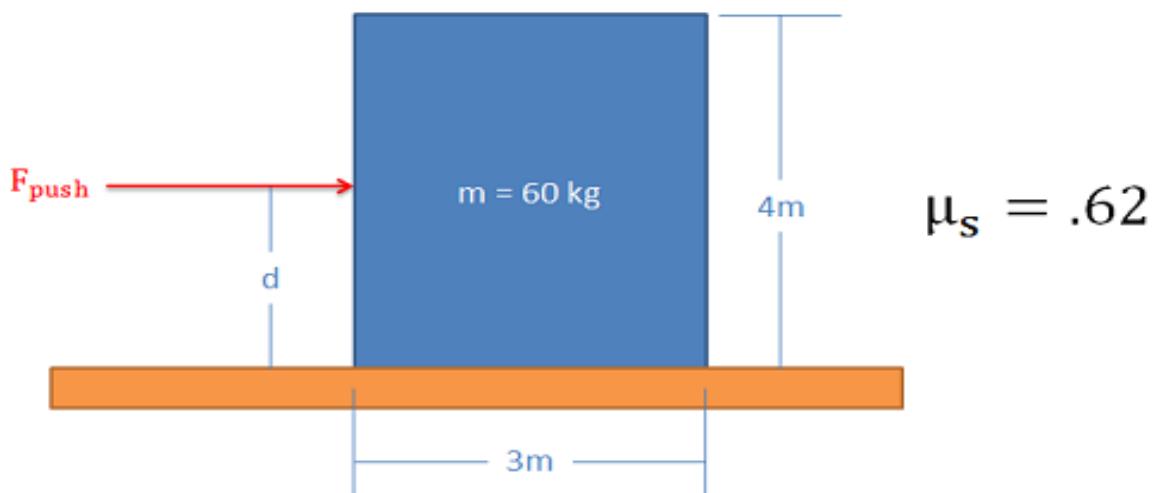

### Solution

We draw free body diagram (FBD) as shown and apply equilibrium conditions  
Slipping Case  $F_{push} = F_{Slip} = F_f = \mu R = (0.66)(588) \rightarrow F_{Slip} = 364.56\text{ N}$  (1)

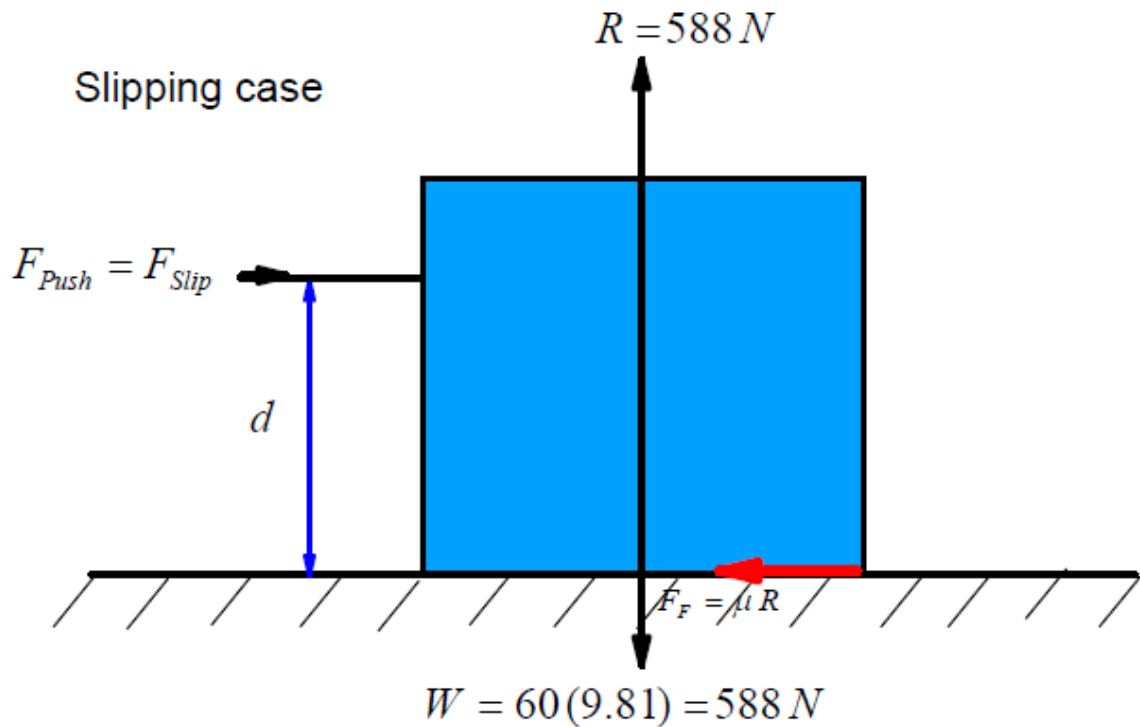

Tipping Case

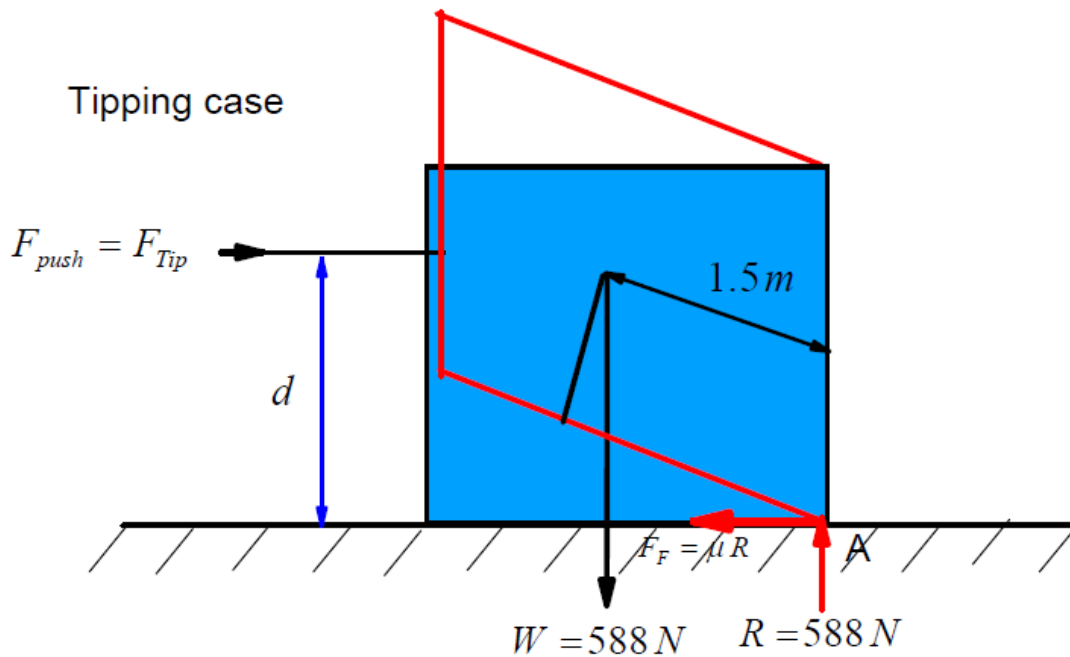

$$F_{Push}(d) = (588)(1.5) \rightarrow F_{Push} = F_{Tip} = \frac{588(1.5)}{d} = \frac{882}{d}\text{ N} \quad (2)$$

The box slipping along the surface before tipping over, if  $F_{Slip} < F_{Tip}$ .

From Eqs. (1) and (2), we find that

$$364 < \frac{882}{d} \rightarrow d < \frac{882}{364} \rightarrow d < \frac{882}{364} = 2.423\text{ m}.$$

So the box will Slipping first if  $d = 2.42\text{ m}$ .



Example 3: The refrigerator has a weight of  $180\text{ lb}$  and rests on a tile floor for which  $\mu = 0.25$ . Also, the man has a weight of  $150\text{ lb}$  and the coefficient of static friction between the floor and his shoes is  $\mu = 0.6$ . If he pushes horizontally on the refrigerator, determine if he can move it. If so, does the refrigerator slip or tip?

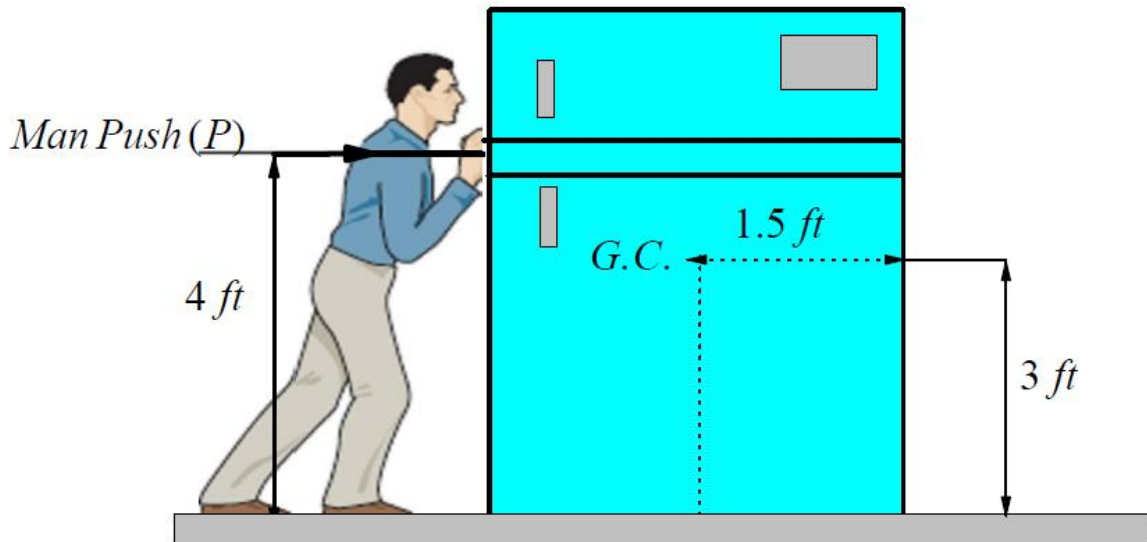

### Solution

We consider the man can be able to move the refrigerator (slipping or tipping case) and we study the case of refrigerator and man everyone alone

The case of refrigerator

(a) The slipping case

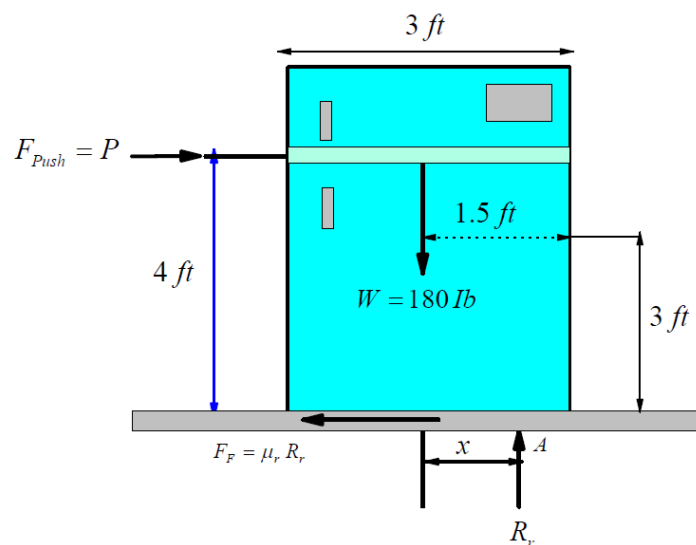

Assuming that the refrigerator is on the verge of slipping, so

$$\sum F_y = 0 \rightarrow R_r = W = 180\text{ lb} \quad (1)$$

$$\sum F_x = 0 \rightarrow$$

$$F_{Push} = F_{Slipping} = F_F = \mu_r R_r = (0.25)(180) \rightarrow F_{Push} = F_{Slipping} = 45 Ib \quad (2)$$

(b) The tipping case

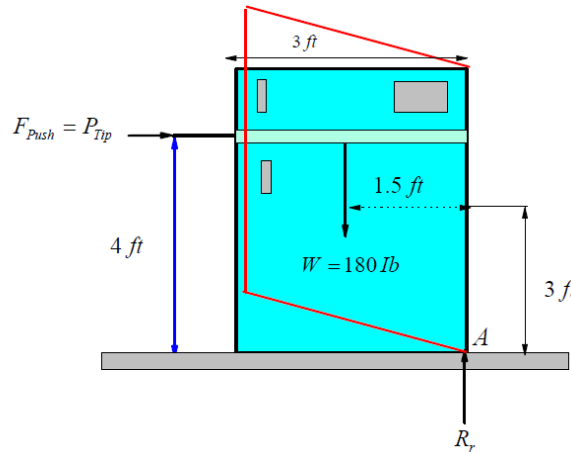

Assuming that the refrigerator is on the verge of tipping, so

$$\sum F_y = 0 \rightarrow R_r = W = 180 Ib \quad (3)$$

$$\sum M_A = 0 \rightarrow P(4) - 180(1.5) = 0 \rightarrow P_{push} = P_{tipping} = 67.5 \quad (4)$$

From Eqs. (2) and (4), we note that  $F_{Slipping} = 45 < P_{Tipping} = 67.5$ .

So the refrigerator does not tipping, but it slipping.

Check  $x$ :  $\sum M_A = 0 \rightarrow 45(4) - 180(x) = 0 \rightarrow x = 1 ft < 1.5$

Since  $x < 1.5$ . Again this confirms that the refrigerator does not tipping, but it slipping.

Therefore, the correct assumption is that, the refrigerator slipping.

So  $F_{Push} = F_{Slipping} = 45 Ib$

The case of man

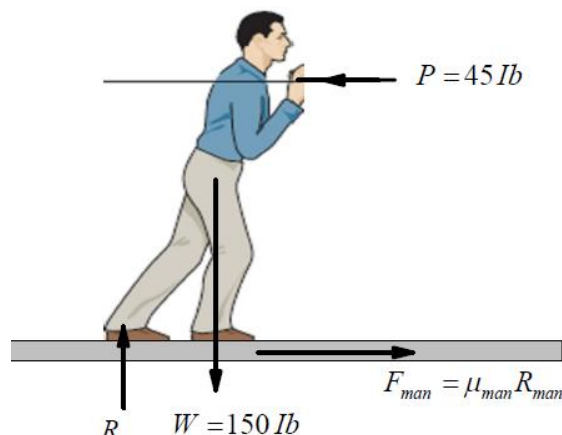

$$\sum F_y = 0 \rightarrow R_{man} = W = 150 \text{ lb} \quad (3)$$

$$\sum F_x = 0 \rightarrow F_{man} = 45 \text{ lb} \quad (4)$$

$$\text{But } (F_{man})_{\max} = (F_{man})_{\text{friction}} = \mu_{man} R_{man} = (0.6)(150) = 90 \text{ lb} \quad (5)$$

Since  $(F_{man})_{\text{friction}} = 90 > F_{man} = 45$ , so the man does not slip. Thus the man is capable of moving refrigerator.

**Example:4** A regular square plate rest with one of its sides on a rough inclined plane of inclination  $\frac{\pi}{6}$ . A gradually increased force acts upwards at higher point of the plate. Prove that the plate will tipping before slipping if the coefficient of friction is greater than  $\frac{3-\sqrt{3}}{7+\sqrt{3}}$ .

### Solution

We draw free body diagram (FBD) as shown and apply equilibrium conditions

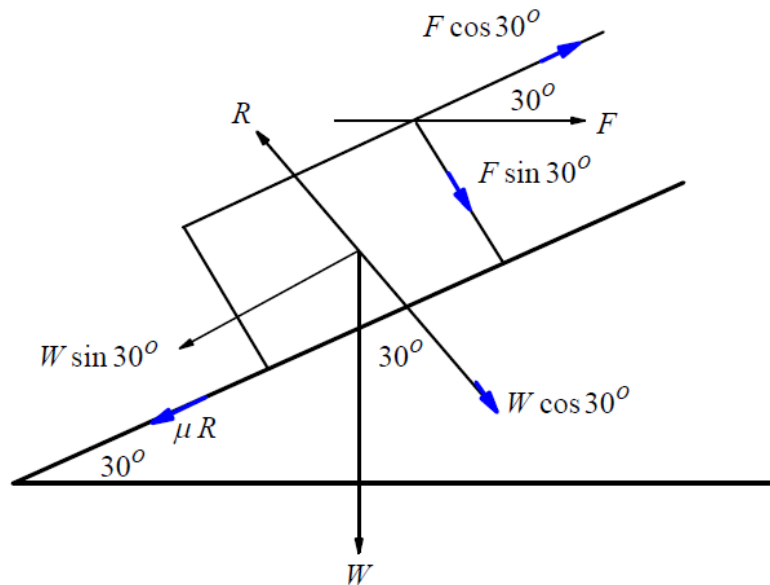

### Slipping Case

$$\sum F_x = 0 \rightarrow F_{\text{slip}} \cos 30^\circ = \mu R + W \sin 30^\circ \rightarrow \frac{\sqrt{3}}{2} F_{\text{slip}} = \mu R + \frac{1}{2} W \quad (1)$$

$$\sum F_y = 0 \rightarrow R = F_{\text{slip}} \sin 30^\circ + W \cos 30^\circ \rightarrow R = \frac{1}{2} F_{\text{slip}} + \frac{\sqrt{3}}{2} W \quad (2)$$

From Eq. (2) into Eq. (1)

$$\frac{\sqrt{3}}{2} F_{slip} = \mu \left\{ \frac{1}{2} F_{slip} + \frac{\sqrt{3}}{2} W \right\} + \frac{1}{2} W \rightarrow \frac{\sqrt{3}}{2} F_{slip} - \frac{1}{2} \mu F_{slip} = \frac{\sqrt{3}}{2} W \mu + \frac{1}{2} W$$

$$(\sqrt{3} - \mu) F_{slip} = (\mu\sqrt{3} + 1) W \rightarrow F_{slip} = \left( \frac{\mu\sqrt{3} + 1}{\sqrt{3} - \mu} \right) W \quad (3)$$

### Tipping Case

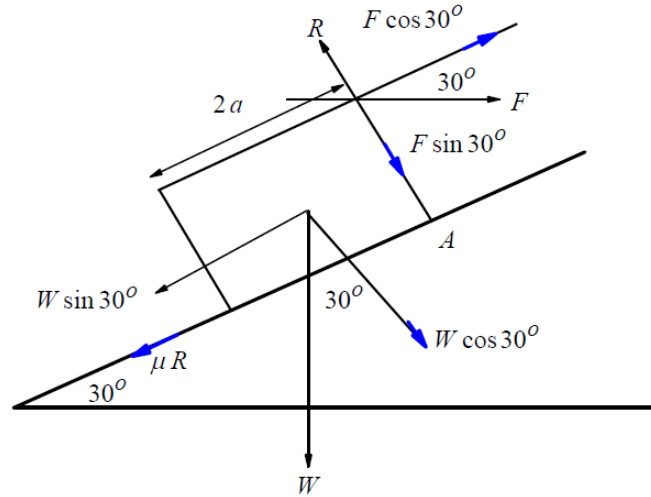

$$\sum F_y = 0 \rightarrow R = F_{tip} \sin 30^\circ + W \cos 30^\circ \rightarrow R = \frac{1}{2} F_{tip} + \frac{\sqrt{3}}{2} W \quad (4)$$

The moment at pint A

$$\sum M_A = 0 \rightarrow W \sin 30^\circ (a) + W \cos 30^\circ (a) = F_{Tip} \cos 30^\circ (2a)$$

$$\frac{1}{2} W (a) + \frac{\sqrt{3}}{2} (a) W = F_{Tip} \frac{\sqrt{3}}{2} (2a) \rightarrow (1 + \sqrt{3}) W = 2\sqrt{3} F_{Tip}$$

$$F_{Tip} = \frac{1 + \sqrt{3}}{2\sqrt{3}} W \quad (5)$$

The plate tipping over before slipping if .  $F_{Tip} < F_{slip}$  , then

$$\frac{1 + \sqrt{3}}{2\sqrt{3}} W < \left( \frac{\mu\sqrt{3} + 1}{\sqrt{3} - \mu} \right) W \rightarrow (\sqrt{3} - \mu)(1 + \sqrt{3}) < 2\sqrt{3}(\mu\sqrt{3} + 1)$$

$$\rightarrow \sqrt{3} + 3 - \mu - \sqrt{3}\mu < 6\mu + 2\sqrt{3} \rightarrow \sqrt{3} + 3 - \sqrt{3}\mu < 7\mu + 2\sqrt{3}$$

$$\rightarrow 3 - \sqrt{3} < (7 + \sqrt{3})\mu \rightarrow \mu > \frac{3 - \sqrt{3}}{7 + \sqrt{3}}$$

Problem: The drum has a weight of  $100lb$  and rests on the floor for which the coefficient of static friction is  $\mu_s = 0.5$  as shown in Figure. If  $a = 3\text{ ft}$  and  $b = 4\text{ ft}$ , determine the smallest magnitude of the force  $P$  that will cause impending motion of the Drum?

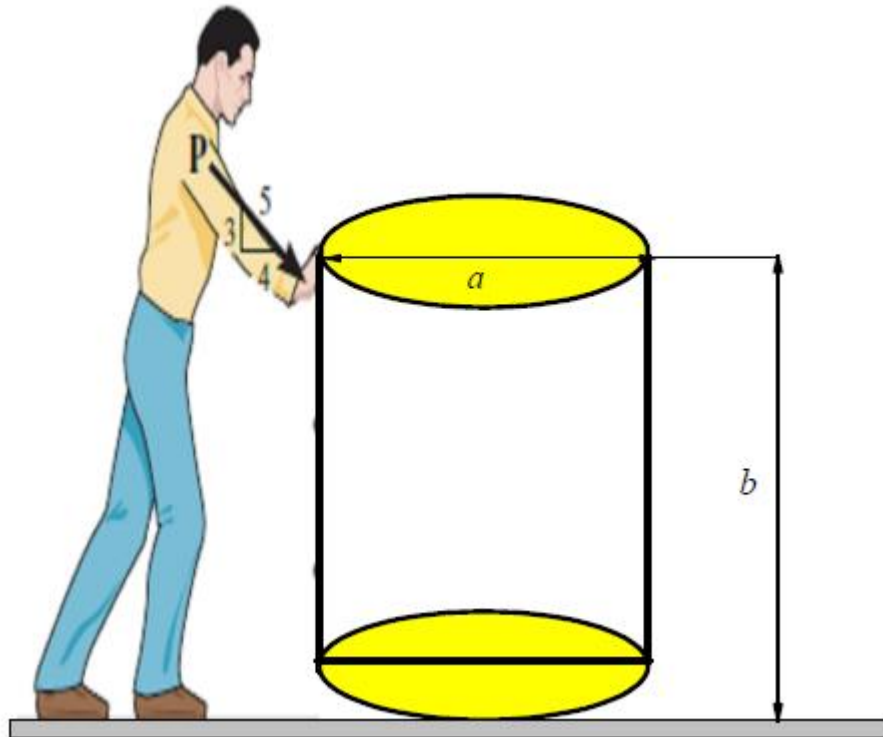

## Chapter 5

### Center of Gravity, Center of Mass and Centroids

#### Introduction

Center of Gravity. A body is composed of an infinite number of particles of differential size, and so if the body is located within a gravitational field, then each of these particles will have a weight  $dW$ , Fig. 1(a). These weights will form an approximately parallel force system, and the resultant of this system is the total weight of the body, which passes through a single point called the center of gravity,  $G$ , Fig. 1(b).

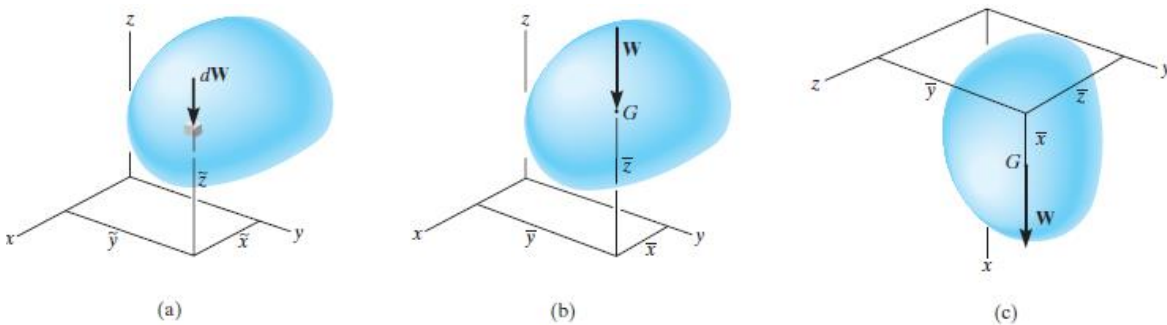

It well known that, the weight of the body is the sum of the weights of all of its particles, that is

$$F_R = \sum F_z \quad \text{Or} \quad W = \int dW$$

The location of the center of gravity, measured from the  $y$  axis, is determined by equating the moment of  $W$  about the  $y$  axis, Fig.1(b), to the sum of the moments of the weights of the particles about this same axis. If  $dW$  is located at point  $(x, y, z)$ , Fig.1(a), then

$$(M_R)_x = \sum M_x \quad \text{Or} \quad \bar{x}W = \int \bar{x} dW$$

Similarly, if moments are summed about the  $y$  axis,

$$(M_R)_y = \sum M_y \quad \text{Or} \quad \bar{y}W = \int \bar{y} dW$$

Also:

$$(M_R)_z = \sum M_z \quad \text{Or} \quad \bar{z}W = \int \bar{z} dW$$

Therefore, the location of the center of gravity  $G$  with respect to the  $x, y, z$  axes becomes

$$\bar{x} = \frac{\int \tilde{x} dW}{\int dW}, \quad \bar{y} = \frac{\int \tilde{y} dW}{\int dW}, \quad \bar{z} = \frac{\int \tilde{z} dW}{\int dW}.$$

$\tilde{x}, \tilde{y}, \tilde{z}$  are the coordinates of each particle in the body .  
 $\bar{x}, \bar{y}, \bar{z}$  are the coordinates of the center of gravity  $G$ .

In

### The Center of mass

order to study the dynamic response or accelerated motion of a body, it becomes important to locate the body's center of mass (Cm) .

This location can be determined by substituting  $dW = g dm$  . Since  $g$  is constant, it cancels out, and so

$$\bar{x} = \frac{\int \tilde{x} dm}{\int dm}, \quad \bar{y} = \frac{\int \tilde{y} dm}{\int dm}, \quad \bar{z} = \frac{\int \tilde{z} dm}{\int dm}.$$

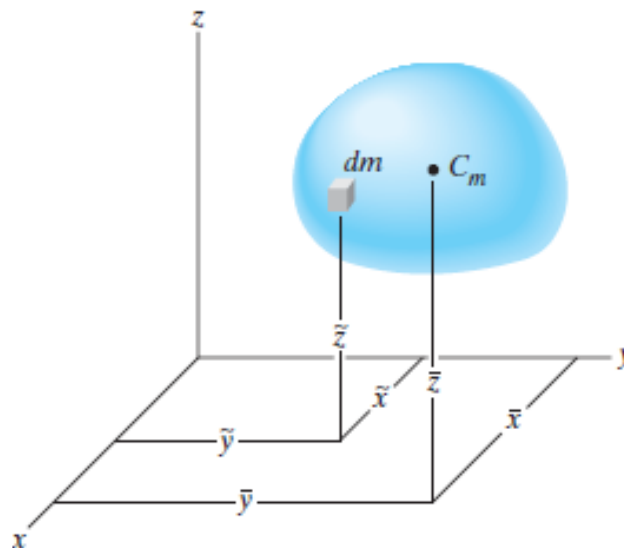

### Definition: The Center of gravity

The Center of gravity, that point in a body (or system) around which its mass or weight is evenly distributed (or balanced) and through which the force of gravity acts

The definition of center of gravity is the place in a system or body where the weight is evenly dispersed and all sides are in balance.

Center of Gravity: point locates the resultant weight

## Centroid:

point defines the geometric center

If the material composing a body is uniform or homogeneous, the density or specific weight will be constant throughout the body, then the centroid is the same as the center of gravity or center of mass.

## Line Centroid:

The coordinates of the Centroid of Line given by

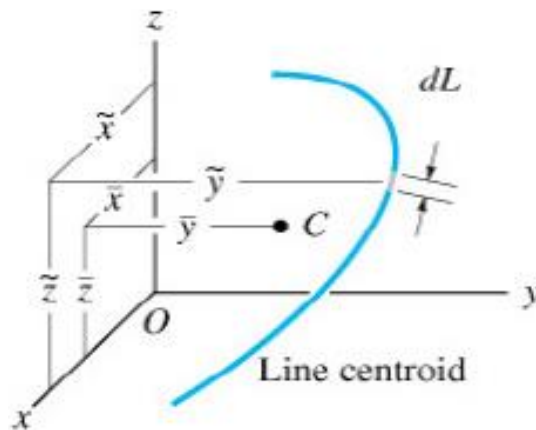

$$\bar{x} = \frac{\int \tilde{x} dL}{\int dL}, \quad \bar{y} = \frac{\int \tilde{y} dL}{\int dL}$$

## Area Centroid

The coordinates of the Centroid of Area given by

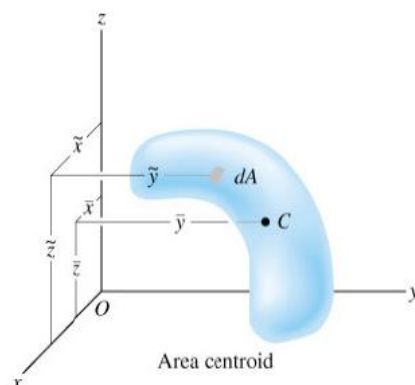



$$\bar{x} = \frac{\int \tilde{x} dA}{\int_A dA}, \quad \bar{y} = \frac{\int \tilde{y} dA}{\int_A dA}$$

**Volume Centroid:**

The coordinates of the Centroid of Volume of a body with volume  $V$  are given by

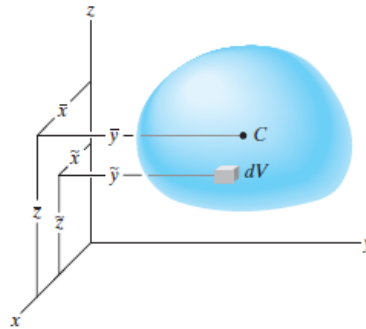

$$\bar{x} = \frac{\int x dV}{\int_V dV}, \quad \bar{y} = \frac{\int y dV}{\int_V dV}, \quad \bar{z} = \frac{\int z dV}{\int_V dV}$$

**Remark:**

For a homogeneous body ( $\rho = \text{const}$ ), the center of mass and the centroid of the volume coincide.

## Examples

**Example 1:** Determine the Center of Mass of a thin uniform Rod?

### Solution

Let  $AB = L$  be the length of a uniform rod or a uniform strip with its middle point  $G$ . The mass per unit length of this rod or strip is uniform at all points. For any elemental mass ( $dm$ ) at any point located at distance ( $x$ ) from the end (beginning) of Rod as shown in Figure.

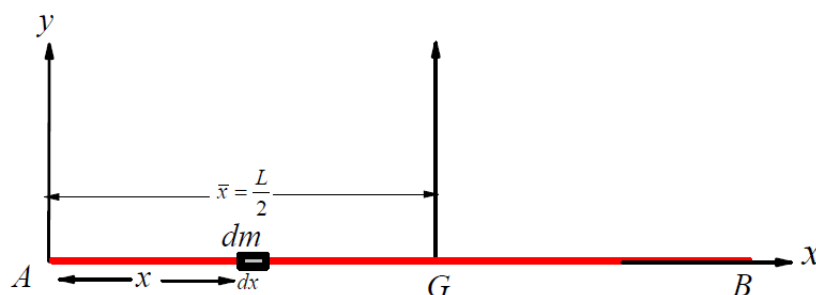

The Centre of Mass of a thin uniform Rod is given by

$$\bar{x} = \frac{\int \tilde{x} dm}{\int dm},$$

where  $dm = \rho dx$ ,

Then

$$\bar{x} = \frac{\int_0^L \tilde{x} dm}{\int_0^L dm} = \frac{\int_0^L x \rho dx}{\int_0^L \rho dx} = \frac{\int_0^L x dx}{\int_0^L dx} = \frac{\frac{1}{2} x^2 \Big|_0^L}{x \Big|_0^L} = \frac{\frac{1}{2}(L^2 - 0)}{L - 0} = \frac{\frac{1}{2}L^2}{L} = \frac{1}{2}L$$

Then  $\bar{x} = \frac{1}{2}L, \quad \bar{y} = 0, \quad \bar{z} = 0.$

Example:2 Determine the center of mass for Rod of non-uniform density, where the density varies from one end to the other?

### Solution

Let  $AB = L$  be the length of a uniform rod or a uniform strip with its middle point  $G$ . The mass per unit length of this rod or strip is uniform at all points. For any elemental mass ( $dm$ ) at any point located at distance ( $x$ ) from the end (beginning) of Rod as shown in Figure.

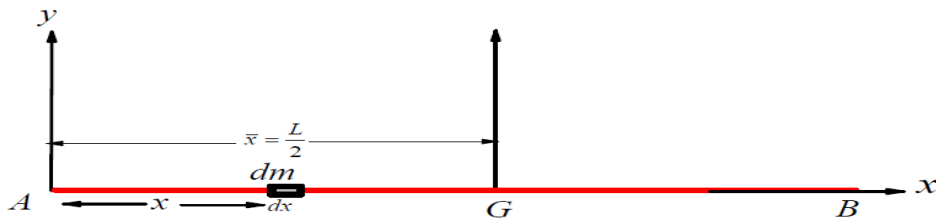

The Centre of Mass of a thin uniform Rod is given by

$$\bar{x} = \frac{\int \tilde{x} dm}{\int dm}$$

If the density varies as a function of distance from end (beginning) of the Rod  $\rho = \lambda x$  and  $dm = \rho dx \rightarrow dm = \lambda x dx$  then

$$\bar{x} = \frac{\int_0^L x \, dm}{\int_0^L dm} = \frac{\int_0^L x (\lambda x) \, dx}{\int_0^L \lambda x \, dx} = \frac{\int_0^L x^2 \, dx}{\int_0^L x \, dx} = \frac{\frac{1}{2} x^3 \Big|_0^L}{\frac{1}{2} x^2 \Big|_0^L}$$

$$\bar{x} = \frac{\frac{1}{3}(L^3 - 0)}{\frac{1}{2}(L^2 - 0)} = \frac{\frac{1}{3}L^3}{\frac{1}{2}L^2} = \frac{2}{3}L$$

Then  $\bar{x} = \frac{2}{3}L$

**Example 3:** Determine the center of mass of a uniform square Plate (one of the Uniform (regular- symmetric) Shapes) ?

**Solution**

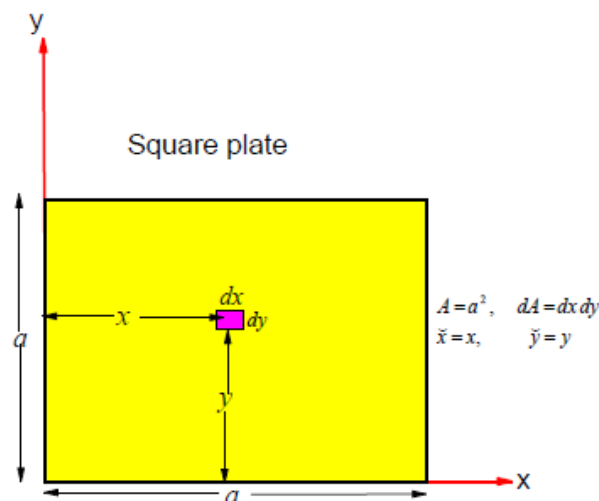

We consider the square Plate as in upper Figure and we select an small strip at distance  $y$  from the  $y$ -axis, and it has  $dx$  length and  $dy$  wide.

Where the shape is homogenous (uniform), then Centre of Mass maybe given by

$$\bar{x} = \frac{\int \bar{x} \, dA}{A}, \quad \bar{y} = \frac{\int \bar{y} \, dA}{A}.$$

Then 
$$\bar{x} = \frac{\int \bar{x} \, dA}{A} = \frac{\int_0^a \int_0^a x \, dx \, dy}{a^2} = \frac{\left[ \frac{x^2}{2} \right]_0^a \left[ y \right]_0^a}{a^2} = \frac{1}{2} \frac{a^3}{a^2} = \frac{1}{2} a.$$

Also

$$\bar{y} = \frac{\int \tilde{y} dA}{A} = \frac{\int_0^a \int_0^a y \, dx dy}{a^2} = \frac{\left[ x \right]_0^a \left[ \frac{y^2}{2} \right]_0^a}{a^2} = \frac{1}{2} \frac{a^3}{a^2} = \frac{1}{2} a$$

Then  $(\bar{x}, \bar{y}) = \left(\frac{a}{2}, \frac{a}{2}\right)$

Exercise: : Determine the Centre of Mass of a uniform Rectangular Plate?

Example 4: Determine the Center of Gravity of a uniform (is uniform thickness and constant density) right Triangular Plate ?

### Solution

We consider the right Triangular Plate as in Figure and we select an small element at any point located at distance  $(x, y)$  from the  $x$  – axis and  $y$  – axis, respectively.

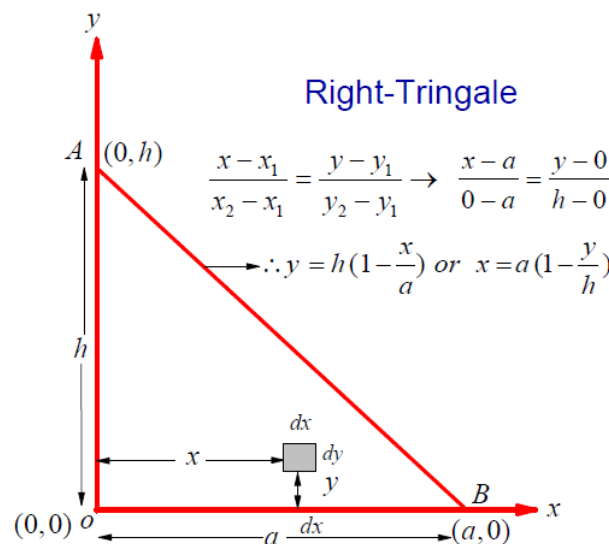

The Centre of Mass is given by

$$\bar{x} = \frac{\int \tilde{x} \, dm}{\int dm}, \quad \bar{y} = \frac{\int \tilde{y} \, dm}{\int dm}, \quad \bar{z} = 0.$$

Note that, for the triangle  $\frac{x}{a} + \frac{y}{h} = 1$

$$\bar{x} = \frac{\int_A x \, dm}{\int_A dm} = \frac{\int_0^h \int_0^{a(1-\frac{y}{h})} x \rho \, dx dy}{\int_0^h \int_0^{a(1-\frac{y}{h})} \rho \, dx dy} = \frac{\int_0^h \left[ \frac{x^2}{2} \right]_0^{a(1-\frac{y}{h})} dy}{\int_0^h \left[ x \right]_0^{a(1-\frac{y}{h})} dy} = \frac{\frac{1}{2} \int_0^h \left[ a^2 \left(1 - \frac{y}{h}\right)^2 - 0 \right] dy}{\int_0^h \left[ a \left(1 - \frac{y}{h}\right) - 0 \right] dy}$$

$$= \frac{\frac{a^2}{2} \int_0^h \left[ 1 - 2\frac{y}{h} + \frac{y^2}{h^2} \right] dy}{a \int_0^h \left[ 1 - \frac{y}{h} \right] dy} = \frac{a}{2} \frac{\left[ y - \frac{2y^2}{2h} + \frac{y^3}{3h^2} \right]_0^h}{\left[ y - \frac{y^2}{2h} \right]_0^h} = \frac{a}{2} \frac{\left[ h - \frac{2h^2}{2h} + \frac{h^3}{3h^2} - 0 \right]}{\left[ h - \frac{h^2}{2h} - 0 \right]}$$

$$\bar{x} = \frac{a}{2} \frac{\left[ h - h + \frac{h}{3} \right]}{\left[ h - \frac{h}{2} \right]} = \frac{a}{2} \frac{\frac{h}{3}}{\frac{h}{2}} = \frac{a}{3}.$$

Similarly, we can prove that  $\bar{y} = \frac{h}{3}$

Then

$$(\bar{x}, \bar{y}) = \left( \frac{a}{3}, \frac{h}{3} \right)$$

**Example 5:** Determine the center of mass of right Triangular Plate (uniform thickness and constant density) as is in the below Figure ?

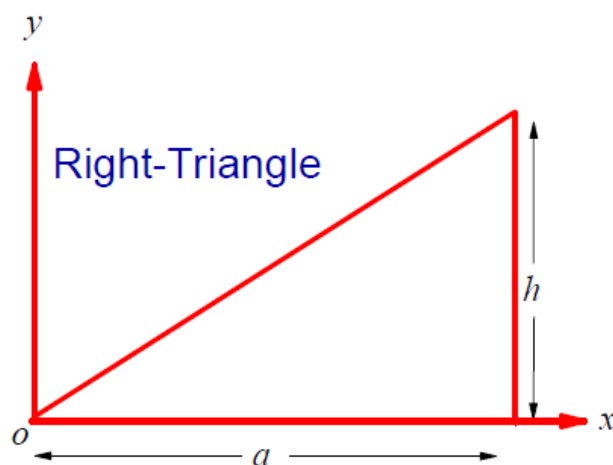

**Solution**

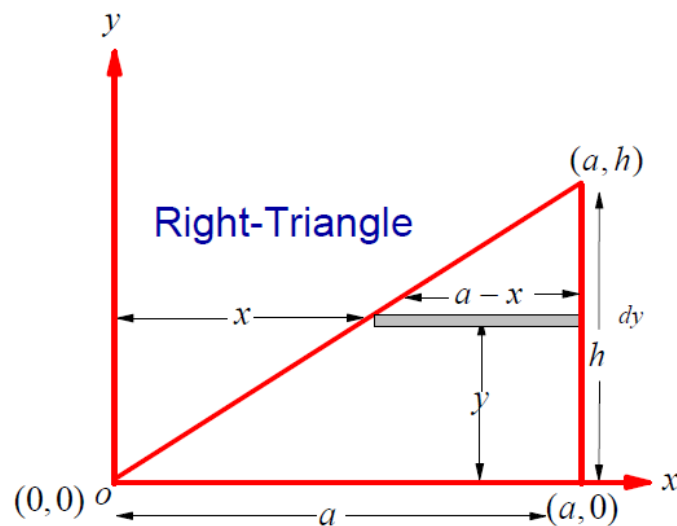

The Centre of Mass is given by  $\bar{x} = \frac{\int \tilde{x} dA}{\int_A dA}$ ,  $\bar{y} = \frac{\int \tilde{y} dA}{\int_A dA}$ ,

$$\begin{aligned} \bar{x} &= \frac{\int \tilde{x} dA}{\int_A dA} = \frac{\int_0^a x y dx}{\frac{1}{2} a h} = \frac{1}{\frac{1}{2} a h} \int_0^a x h \left(1 - \frac{x}{a}\right) dx = \frac{2}{a} \int_0^a \left(x - \frac{x^2}{a}\right) dx \\ &= \frac{2}{a} \left(\frac{x^2}{2} - \frac{x^3}{3a}\right)_0^a = \frac{2}{a} \left(\frac{a^2}{2} - \frac{a^2}{3}\right) = \frac{2a^2}{6a} (3-2) = \frac{2}{3} a \end{aligned}$$

Also,

$$\begin{aligned} \bar{y} &= \frac{\int \tilde{y} dA}{\int_A dA} = \frac{\int_0^a \frac{1}{2} y (y dx)}{\frac{1}{2} a h} = \frac{1}{a h} \int_0^a y^2 dx = \frac{1}{a h} \int_0^a h^2 \left(1 - \frac{x}{a}\right)^2 dx \\ &= \frac{h}{a} \left(\frac{1}{3} \left(1 - \frac{x}{a}\right)^3\right)_0^a = \frac{h}{3} \left(-\left(1 - \frac{a}{a}\right)^3 + (1-0)^3\right) = \frac{1}{3} h \end{aligned}$$

Then  $(\bar{x}, \bar{y}) = \left(\frac{2}{3} a, \frac{1}{3} h\right)$

**Example 6:** Determine the Center of Mass of arc of Circular arc ?

### Solution

We consider the Circular arc as in Figure and we select an small element at any point located at distance  $(x, y)$  from the origin point or  $(r, \theta)$ . From the figure one can see that, the center of gravity will be point on  $x$ -axis. So the center of gravity will be given as

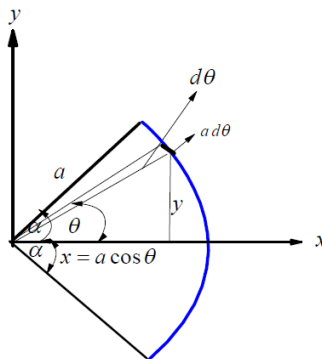

$$\bar{x} = \frac{\int \tilde{x} dL}{\int dL} = \frac{\int x (a d\theta)}{\int a d\theta} = \frac{\int_{-\alpha}^{\alpha} (a \cos\theta) a d\theta}{\int_{-\alpha}^{\alpha} a d\theta} = a \frac{\int_{-\alpha}^{\alpha} \cos\theta d\theta}{\int_{-\alpha}^{\alpha} d\theta} =$$

$$\bar{x} = a \frac{\sin\theta \Big|_{-\alpha}^{\alpha}}{\theta \Big|_{-\alpha}^{\alpha}} = a \frac{\sin\alpha - \sin(-\alpha)}{\alpha - (-\alpha)} = a \frac{\sin\alpha + \sin(\alpha)}{\alpha + \alpha} = a \frac{2 \sin\alpha}{2\alpha} = a \frac{\sin\alpha}{\alpha}$$

Then, the Center of Mass of a Circular arc is  $\bar{x} = a \frac{\sin\alpha}{\alpha}$

**Example 7:** Determine the Center of Mass of a uniform Quarter-circular arc (Wire segment as Quarter-circular) ?

### Solution

We consider the uniform Quarter arc of circle (wire) as in Figure and we select an small element at any point located at distance  $(x, y)$  from the origin point or  $(r, \theta)$ . The Center of Mass will be given as

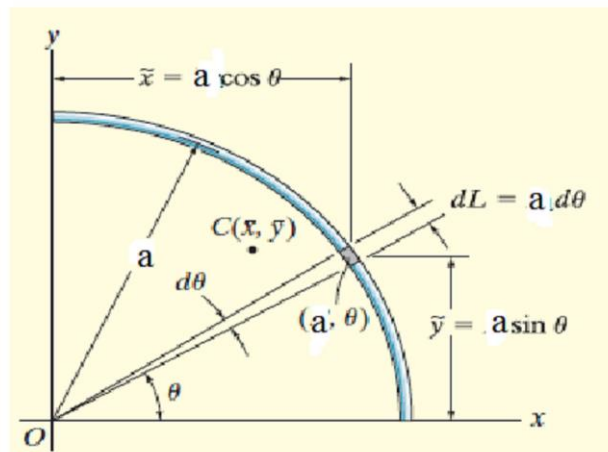

$$\bar{x} = \frac{\int \tilde{x} dm}{\int dm} = \frac{\int x (\rho a d\theta)}{\int \rho a d\theta} = \frac{\int_0^{\frac{\pi}{2}} (a \cos\theta) d\theta}{\int_0^{\frac{\pi}{2}} d\theta} = a \frac{\int_0^{\frac{\pi}{2}} \cos\theta d\theta}{\int_0^{\frac{\pi}{2}} d\theta}$$

$$\bar{x} = a \frac{\sin\theta \Big|_0^{\frac{\pi}{2}}}{\theta \Big|_0^{\frac{\pi}{2}}} = a \frac{\sin(\frac{\pi}{2}) - \sin(0)}{\frac{\pi}{2} - (0)} = a \frac{1+0}{\frac{\pi}{2}} = \frac{2}{\pi} a$$

Similarly,

$$\bar{y} = \frac{\int \tilde{y} dm}{m} = \frac{\int y (\rho a d\theta)}{\frac{1}{4}(2\pi a\rho)} = \frac{\int_0^{\frac{\pi}{2}} (a \sin \theta) a d\theta}{\frac{1}{2}\pi} = a \frac{\int_0^{\frac{\pi}{2}} \sin \theta d\theta}{\frac{1}{2}\pi}$$

$$\bar{y} = -a \frac{\cos \theta \Big|_0^{\frac{\pi}{2}}}{\frac{\pi}{2}} = -a \frac{\cos(\frac{\pi}{2}) - \cos(0)}{\frac{\pi}{2}} = -a \frac{0 - 1}{\frac{\pi}{2}} = \frac{2}{\pi} a$$

Then, the Center of Mass of a uniform Quarter arc of circle is  $(\bar{x}, \bar{y}) = (\frac{2}{\pi} a, \frac{2}{\pi} a)$

Exercise: Determine the center of Mass of a uniform semi-circular arc (uniform Semicircle wire)? .....

The center of Mass of a uniform Semicircle wire is e Exercis . Prove that?  $[0, \pi]$ , where the integral will be in the interval  $(\bar{x}, \bar{y}) = (0, \frac{4}{\pi} a)$

:Determine the center of gravity of a uniform circular arc?

Example 8: Determine the Center of Mass of a Circular sector?

### Solution

We consider the uniform a Circular sector as in Figure and select an small element .

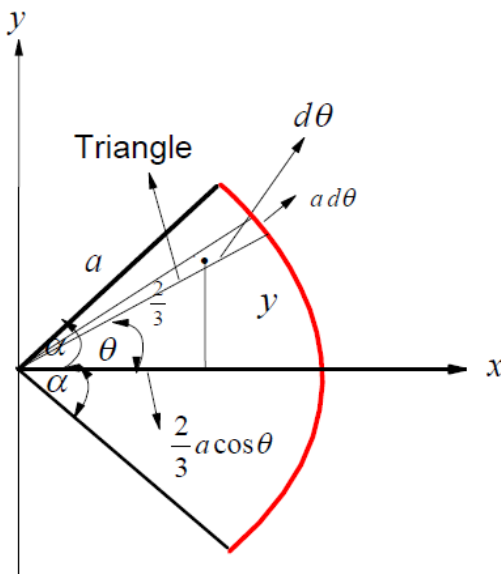

The Centroid of Area (Center of Mass) for this element will be given as



$$\bar{x} = \frac{\int \tilde{x} dA}{\int dA} = \frac{\int \frac{2}{3} a \cos \theta (\frac{1}{2} a (a d\theta))}{\int (\frac{1}{2} a (a d\theta))} = \frac{\frac{1}{3} a \int_{-\alpha}^{\alpha} \cos \theta d\theta}{\int d\theta} = \frac{2a}{3} \frac{\int_{-\alpha}^{\alpha} \cos \theta d\theta}{\int_{-\alpha}^{\alpha} d\theta}$$

$$\bar{x} = \frac{2a}{3} \frac{\sin \theta \Big|_{-\alpha}^{\alpha}}{\theta \Big|_{-\alpha}^{\alpha}} = \frac{2a}{3} \frac{\sin \alpha - \sin(-\alpha)}{\alpha - (-\alpha)} = \frac{2a}{3} \frac{\sin \alpha + \sin(\alpha)}{\alpha + \alpha} = \frac{2a}{3} \frac{2 \sin \alpha}{2\alpha}$$

$$\bar{x} = \frac{2a}{3} \frac{\sin \alpha}{\alpha}$$

Then the Centroid of Area (Center of Mass) of a uniform Circular sector given by

$$\left( \bar{x}, \bar{y} \right) = \left( \frac{2a}{3} \frac{\sin \alpha}{\alpha}, 0 \right)$$

**Example 9: Determine the Center of Mass of a Semicircle area?**

### Solution

We consider the uniform Semicircle area as in Figure and we select an small element at any point

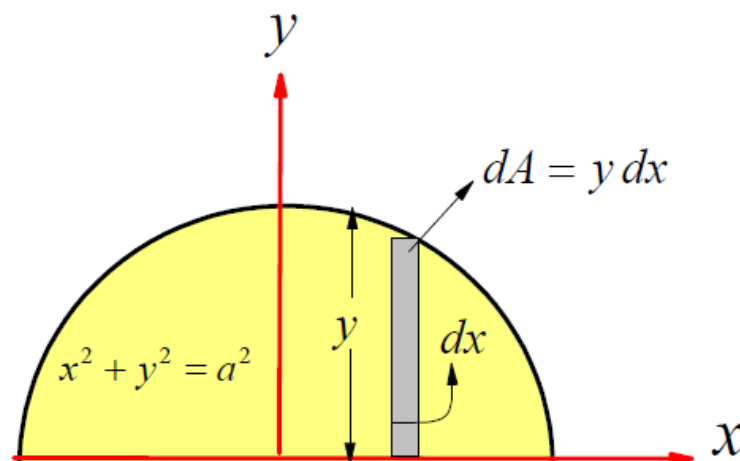

The Centroid of Area (Center of Mass) will give as

$$\bar{x} = \frac{\int \tilde{x} dA}{\int_A dA}, \quad \bar{y} = \frac{\int \tilde{y} dA}{\int_A dA}$$

Form the Figure one can see that,,  $\bar{x} = 0$

$$\bar{y} = \frac{\int_A \bar{y} dA}{\int_A dA} = \frac{\int_{-a}^a \frac{y}{2} (y dx)}{A} = \frac{\frac{1}{2} \int_{-a}^a y^2 dx}{\frac{1}{2} (\pi a^2)} = \frac{\int_{-a}^a (a^2 - x^2) dx}{\pi a^2} = \frac{\left( a^2 x - \frac{x^3}{3} \right) \Big|_{-a}^a}{\pi a^2}$$

$$\bar{y} = \frac{\left( a^3 - \frac{a^3}{3} \right) - \left( -a^3 + \frac{a^3}{3} \right)}{\pi a^2} = \frac{\left( \frac{2a^3}{3} \right) - \left( -\frac{2a^3}{3} \right)}{\pi a^2} = \frac{\left( \frac{4a^3}{3} \right)}{\pi a^2} = \frac{4a}{3\pi}$$

Then  $(\bar{x}, \bar{y}) = \left( 0, \frac{4a}{3\pi} \right)$

**Example 10: Determine the Center of Mass of a Quarter Circle area?**

### Solution

We consider the uniform Quarter Circle area as in Figure and we select an small element at any point

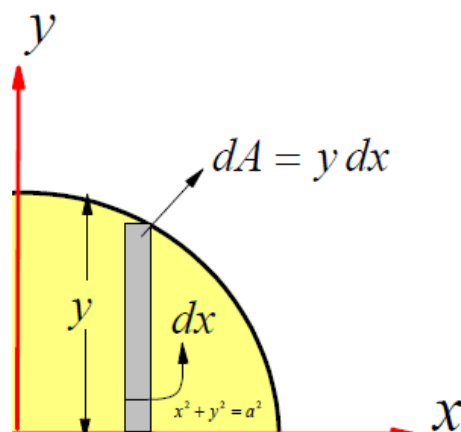

We known that, the Centroid of area (Center of Mass ) of a body with area A are given by be given as

$$\bar{x} = \frac{\int_A \bar{x} dA}{\int_A dA}, \quad \bar{y} = \frac{\int_A \bar{y} dA}{\int_A dA}$$

$$\bar{y} = \frac{\int_A y dA}{\int_A dA} = \frac{\int_0^a \frac{y}{2} (y dx)}{A} = \frac{\frac{1}{2} \int_0^a y^2 dx}{\frac{1}{4} (\pi a^2)} = \frac{\int_0^a (a^2 - x^2) dx}{\pi a^2} = \frac{\left( a^2 x - \frac{x^3}{3} \right) \Big|_0^a}{\pi a^2}$$

$$\bar{y} = 2 \frac{\left( a^3 - \frac{a^3}{3} \right)}{\pi a^2} = 2 \frac{\left( \frac{2a^3}{3} \right)}{\pi a^2} = \frac{\left( \frac{4a^3}{3} \right)}{\pi a^2} = \frac{4a}{3\pi}$$

Similarly, we can prove that  $\bar{x} = \frac{4a}{3\pi}$

$$\text{Then } (\bar{x}, \bar{y}) = \left( \frac{4a}{3\pi}, \frac{4a}{3\pi} \right)$$

**Example 11:** Determine the Center of Mass of a uniform Hollow hemisphere?

### Solution

The Center of Mass is given by

$$\bar{x} = \frac{\int \tilde{x} dm}{\int dm}, \quad \bar{y} = \frac{\int \tilde{y} dm}{\int dm}, \quad \bar{z} = \frac{\int \tilde{z} dm}{\int dm}$$

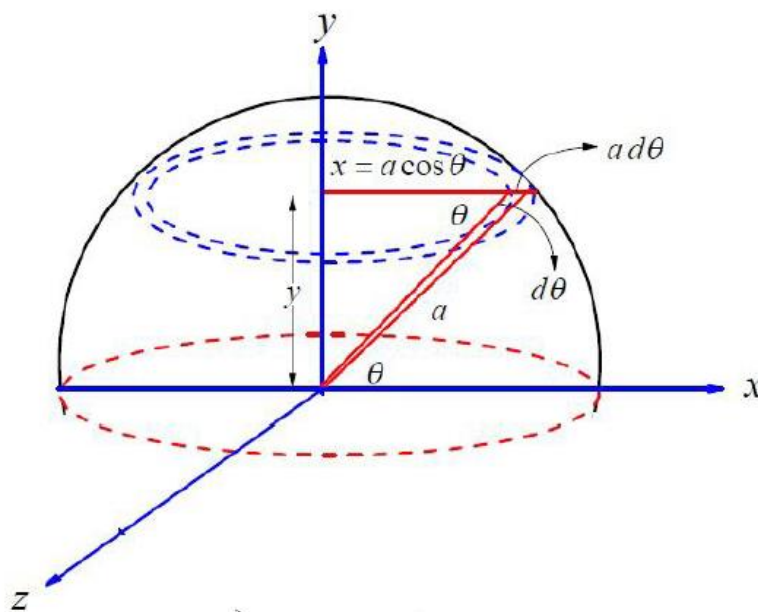

It is well-known that,

$$dm = 2\pi x (a d\theta) \rho = 2\pi a \cos\theta (a d\theta) \rho$$

$$\bar{y} = \frac{\int \tilde{y} dm}{\int dm} = \frac{\int \tilde{y} dm}{m} = \frac{\int_0^{\pi/2} y (2\pi a \cos\theta (a d\theta) \rho)}{\frac{1}{2}(4\pi a^2 \rho)} = \frac{\int_0^{\pi/2} y \cos\theta d\theta}{1} = \int_0^{\pi/2} a \sin\theta \cos\theta d\theta$$

$$\bar{y} = a \int_0^{\frac{\pi}{2}} \sin \theta \, d(\sin \theta) = a \frac{(\sin \theta)^2}{2} \Big|_0^{\frac{\pi}{2}} = a \frac{\left(\sin \frac{\pi}{2}\right)^2 - (\sin 0)^2}{2} = a \frac{(1)^2 - (0)^2}{2} = \frac{a}{2}$$

Then  $(\bar{x}, \bar{y}, \bar{z}) = (0, \frac{a}{2}, 0)$

**Example 12: Determine the Center of Mass of a uniform Solid hemisphere?**

**Solution**

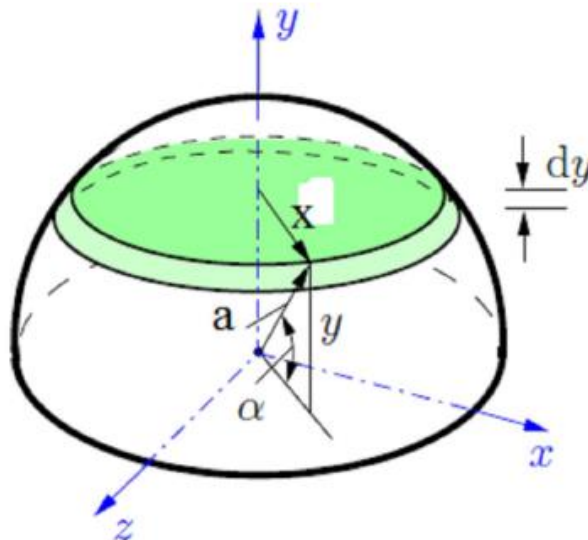

We know that, the Centroid of Volume of a body with volume  $V$  are given by

$$\bar{x} = \frac{\int \tilde{x} dV}{\int_V dV}, \quad \bar{y} = \frac{\int \tilde{y} dV}{\int_V dV}, \quad \bar{z} = \frac{\int \tilde{z} dV}{\int_V dV}.$$

Due to the axisymmetric geometry, we find that

$$\bar{x} = \frac{\int \tilde{x} dV}{\int_V dV} = \bar{z} = \frac{\int \tilde{z} dV}{\int_V dV} = 0$$

Also, we can put  $dV = \pi x^2 dy$  and  $x = a \cos \alpha$ ,  $y = a \sin \alpha$ ,  $dy = a \cos \alpha d\alpha$

Then

$$\bar{y} = \frac{\int \tilde{y} dV}{\int_V dV} = \frac{\int \tilde{y} (\pi x^2 dy)}{V} = \frac{\int (a \sin \alpha) (\pi a^2 \cos^2 \alpha a \cos \alpha d\alpha)}{\frac{1}{2} \left(\frac{4}{3} \pi a^3\right)} = \frac{\int_0^{\frac{\pi}{2}} a^4 \cos^3 \alpha \sin \alpha d\alpha}{\left(\frac{2}{3} a^3\right)}$$

$$\begin{aligned}
&= \frac{3}{2} a \int_0^{\frac{\pi}{2}} \cos^3 \alpha \, d(-\cos \alpha) = -\frac{3}{2} a \int_0^{\frac{\pi}{2}} \cos^3 \alpha \, d(\cos \alpha) = -\frac{3}{2} a \frac{\cos^4 \alpha \Big|_0^{\frac{\pi}{2}}}{4} \\
&= -\frac{3}{8} a \left\{ (\cos(\frac{\pi}{2}))^4 - (\cos(0))^4 \right\} = -\frac{3}{8} a \left\{ (0)^4 - (1)^4 \right\} = \frac{3}{8} a \rightarrow \bar{y} = \frac{3}{8} a
\end{aligned}$$

Then  $(\bar{x}, \bar{y}, \bar{z}) = (0, \frac{3}{8} a, 0)$

**Example 13:** Determine the Center of Mass of a solid and right circular cone of height  $h$  and the base radius  $a$ ?

## Solution

It is clear that the Centroid of Volume (Center of Mass) is given by

$$\bar{x} = \frac{\int \tilde{x} dV}{\int dV}, \quad \bar{y} = \frac{\int \tilde{y} dV}{\int dV}, \quad \bar{z} = \frac{\int \tilde{z} dV}{\int dV}.$$

We consider the circular cone as in Figure and we select an small element at any point located at distance  $x$  from the origin point and its thickness is  $dx$ .

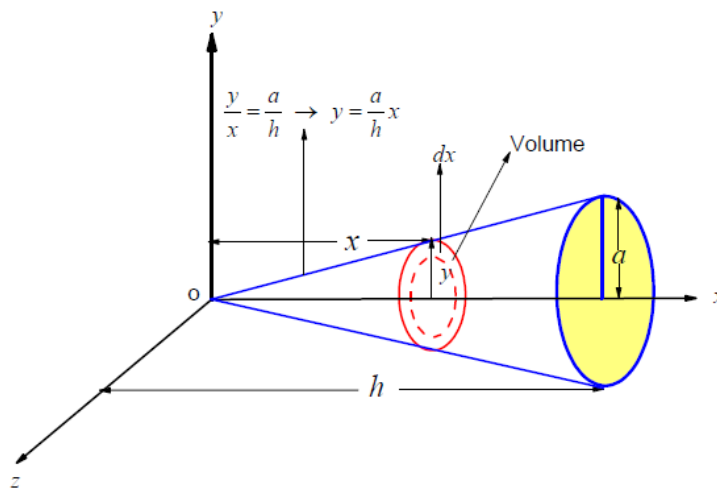

$$\bar{x} = \frac{\int \tilde{x} dV}{\int dV} = \frac{\int_0^h x(\pi y^2 dx)}{\int_0^h (\pi y^2 dx)} = \frac{\int_0^h x(\frac{a}{h}x)^2 dx}{\int_0^h (\frac{a}{h}x)^2 dx} = \frac{\int_0^h x^3 dx}{\int_0^h x^2 dx} = \frac{\frac{1}{4}x^4 \Big|_0^h}{\frac{1}{3}x^3 \Big|_0^h} = \frac{\frac{1}{4}(h^4 - 0)}{\frac{1}{3}(h^3 - 0)} = \frac{3}{4}h$$

Then, the center of gravity of a solid is  $\bar{x} = \frac{3}{4}h$  referenced from the origin point or the center of gravity of a solid is  $\bar{x} = \frac{1}{4}h$  referenced from the base .

Exercise: Determine the Center of Mass of a Hollow and right circular cone of height  $h$  and the base radius  $a$  ?

Example 14: Determine the Centroid of the area shown in below Figure ?

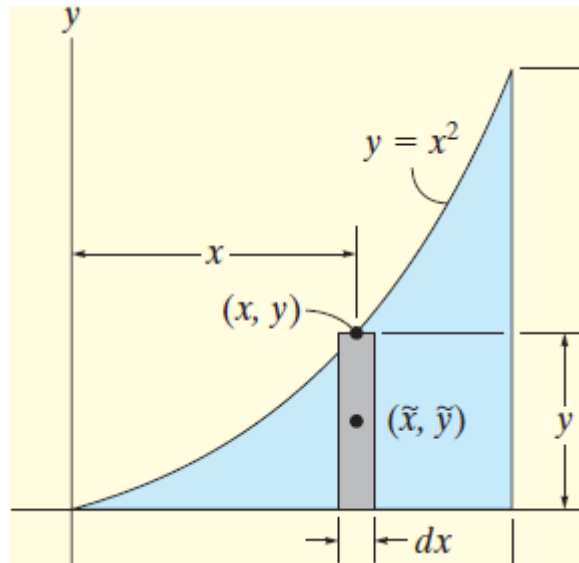

### Solution

The centroid of area (Center of Mass) is given by

$$\bar{x} = \frac{\int \tilde{x} dA}{\int dA}, \quad \bar{y} = \frac{\int \tilde{y} dA}{\int dA}$$

Where  $dA = y dx$ ,  $\tilde{x} = x$ ,  $\tilde{y} = \frac{1}{2}y$ . Then

$$\bar{x} = \frac{\int \tilde{x} dA}{\int dA} = \frac{\int_0^x x y dx}{\int_0^x y dx} = \frac{\int_0^x x x^2 dx}{\int_0^x x^2 dx} = \frac{\int_0^x x^3 dx}{\int_0^x x^2 dx} = \frac{\frac{1}{4}x^4 \Big|_0^x}{\frac{1}{3}x^3 \Big|_0^x} = \frac{3}{4}x,$$

$$\bar{y} = \frac{\int \bar{y} dA}{\int dA} = \frac{\int_0^x \frac{1}{2} y \cdot y dx}{\int_0^x y dx} = \frac{\frac{1}{2} \int_0^x x^2 \cdot x^2 dx}{\int_0^x x^2 dx} = \frac{\frac{1}{2} \int_0^x x^4 dx}{\int_0^x x^2 dx} = \frac{\frac{1}{2} \int_0^x x^4 dx}{\frac{1}{3} x^3 \Big|_0^x} = \frac{\frac{1}{2} \frac{1}{5} x^5 \Big|_0^x}{\frac{1}{3} x^3} = \frac{3}{10} x^2$$

Then  $(\bar{x}, \bar{y}) = (\frac{3}{4}x, \frac{3}{10}x^2) = (\frac{3}{4}y^{\frac{1}{2}}, \frac{3}{10}y^2)$

**Example 15:** Determine the Centroid of the area shown in below Figure ?

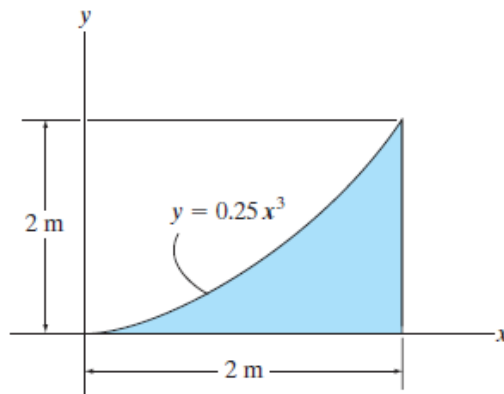

### Solution

We select the small strip as in below Figure

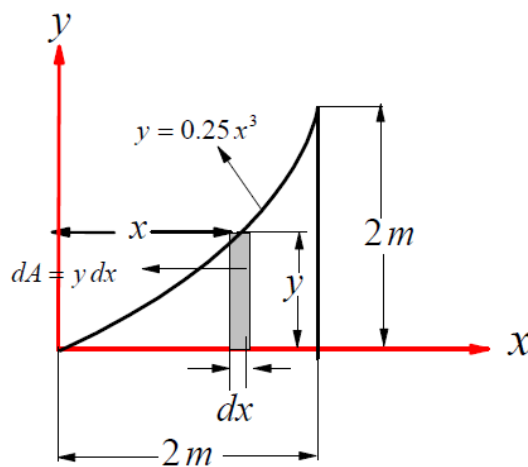

The centroid of area given by  $\bar{x} = \frac{\int \bar{x} dA}{\int dA}$ ,  $\bar{y} = \frac{\int \bar{y} dA}{\int dA}$

Where  $dA = y dx$ ,  $\bar{x} = x$ ,  $\bar{y} = \frac{1}{2}y$ . Then

$$\bar{x} = \frac{\int \bar{x} dA}{\int dA} = \frac{\int_0^x x \cdot y dx}{\int_0^x y dx} = \frac{\int_0^2 x(0.25x^3) dx}{\int_0^2 (0.25x^3) dx} = \frac{\int_0^2 x^4 dx}{\int_0^2 x^3 dx} = \frac{\frac{1}{5}x^5 \Big|_0^2}{\frac{1}{4}x^4 \Big|_0^2} = \frac{4(2)^5}{5(2)^4} = \frac{8}{5} = 1.6\text{ m}$$

$$\bar{y} = \frac{\int \tilde{y} dA}{\int dA} = \frac{\int_0^x (\frac{1}{2}y) y dx}{\int_0^x y dx} = \frac{\frac{1}{2} \int_0^2 (y)^2 dx}{\int_0^2 y dx} = \frac{\frac{1}{2} \int_0^2 (0.25x^3)^2 dx}{\int_0^2 (0.25x^3) dx} = \frac{0.25}{2} \frac{\int_0^2 x^6 dx}{\int_0^2 x^3 dx} = \frac{0.25}{2} \frac{4}{7} \frac{(2)^7}{(2)^4}$$

$$\bar{y} = \frac{0.25}{2} \frac{4}{7} \frac{(2)^7}{(2)^4} = \frac{0.25}{1} \frac{4}{7} \frac{(2)^2}{1} = \frac{25}{100} \frac{8}{7} = \frac{25}{25} \frac{2}{7} = 0.2857m$$

Example 16: Determine the Centroid of the area shown in below Figure?

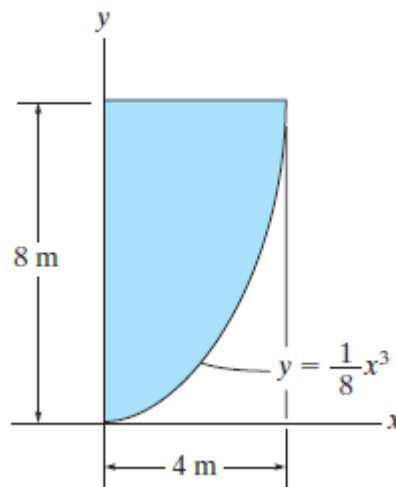

### Solution

We select the small strip as in below Figure

The centroid of area given by  $\bar{x} = \frac{\int \tilde{x} dA}{\int dA}$ ,  $\bar{y} = \frac{\int \tilde{y} dA}{\int dA}$

Where  $dA = x dy$ ,  $\tilde{x} = \frac{1}{2}x$ ,  $\tilde{y} = y$ . Then

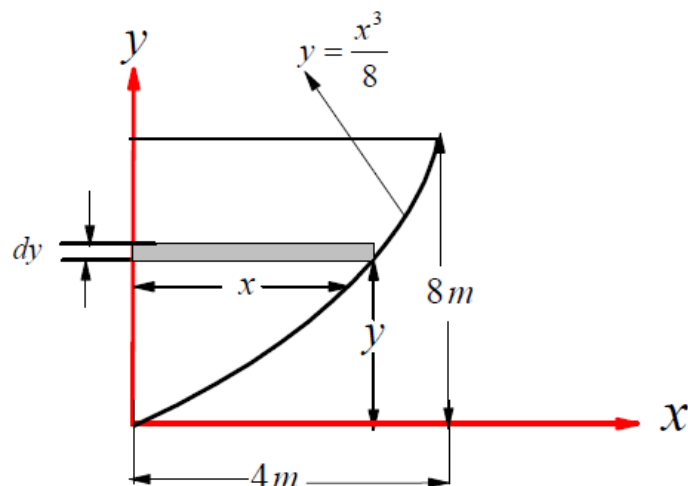



$$\bar{x} = \frac{\int \tilde{x} dA}{\int dA} = \frac{\int_0^y \left(\frac{1}{2}x\right) x dy}{\int_0^y x dy} = \frac{\int_0^4 \left(\frac{1}{2}x\right) x \left(\frac{3}{8}x^2 dx\right)}{\int_0^4 x \left(\frac{3}{8}x^2 dx\right)} = \frac{1}{2} \frac{\int_0^4 x^4 dx}{\int_0^4 x^3 dx} = \frac{1}{2} \frac{\left[\frac{1}{5}x^5\right]_0^4}{\left[\frac{1}{4}x^4\right]_0^4} = \frac{1}{2} \frac{\left[\frac{1}{5}4^5\right]}{\left[\frac{1}{4}4^4\right]}$$

$$\bar{x} = \frac{1}{2} \frac{\frac{4}{5}}{\frac{1}{4}} = \frac{8}{5} = 1.6 \text{ m}$$

$$\bar{y} = \frac{\int \tilde{y} dA}{\int dA} = \frac{\int_0^x y x dy}{\int_0^x x dy} = \frac{\int_0^8 y \left(2y^{\frac{1}{3}}\right) dy}{\int_0^8 \left(2y^{\frac{1}{3}}\right) dy} = \frac{\int_0^8 y^{\frac{4}{3}} dy}{\int_0^8 y^{\frac{1}{3}} dy} = \frac{\left[\frac{3}{7}y^{\frac{7}{3}}\right]_0^8}{\left[\frac{3}{4}y^{\frac{4}{3}}\right]_0^8} = \frac{4}{7} \frac{8^{\frac{7}{3}}}{8^{\frac{4}{3}}} = \frac{4}{7} 8^{\frac{7}{3}-\frac{4}{3}}$$

$$\bar{y} = \frac{4}{7} (8) = \frac{32}{7} = 4.5714$$

Example 17: Determine the Centroid of the area shown in below Figure?

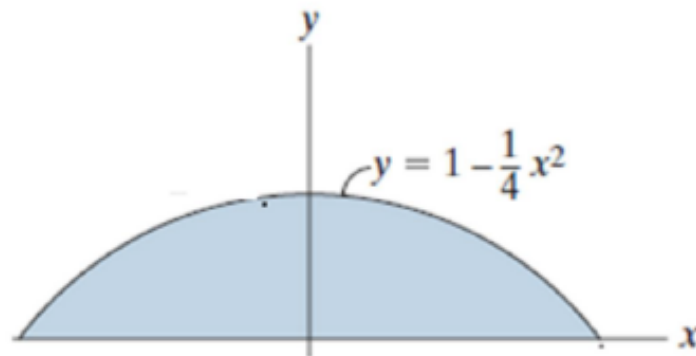

### Solution

We select an small strip as in below Figure

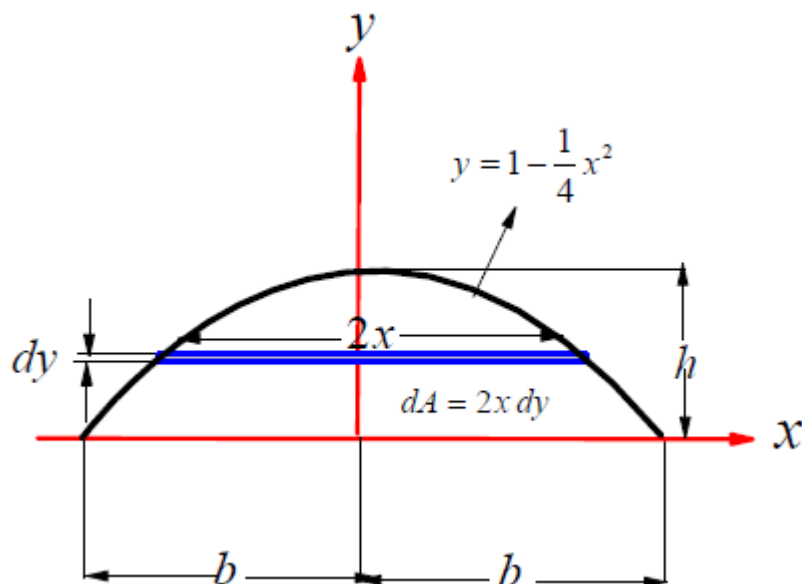

The centroid of area given by  $\bar{x} = \frac{\int \tilde{x} dA}{\int dA}$ ,  $\bar{y} = \frac{\int \tilde{y} dA}{\int dA}$ .

Where  $dA = 2x dy$ ,  $\tilde{x} = x$ ,  $\tilde{y} = y$ . Then

$$\bar{x} = \frac{\int \tilde{x} dA}{\int dA} = \frac{\int_0^x x(2x) dy}{\int_0^x 2x dy} = \frac{\int_{-b}^b 2x^2 \left(-\frac{1}{2} x dx\right)}{\int_{-b}^b 2x \left(-\frac{1}{2} x dx\right)} = \frac{\int_{-b}^b x^3 dx}{\int_{-b}^b x^2 dx}$$

$$\bar{x} = \frac{\left. \frac{1}{4} x^4 \right|_{-b}^b}{\left. \frac{1}{3} x^3 \right|_{-b}^b} = \frac{3}{4} \frac{b^4 - b^4}{b^3 - (-b)^3} = \frac{3}{4} \frac{0}{2} = 0 \quad (\text{Due to symmetry})$$

$$\bar{y} = \frac{\int \tilde{y} dA}{\int dA} = \frac{\int_0^y y(2x dy)}{\int_0^x 2x dy} = \frac{\int_{-b}^b \left(1 - \frac{1}{4} x^2\right) x \left(-\frac{1}{2} x dx\right)}{\int_{-b}^b x \left(-\frac{1}{2} x dx\right)} = \frac{\int_{-b}^b \left(x^2 - \frac{1}{4} x^4\right) dx}{\int_{-b}^b x^2 dx}$$

$$\bar{y} = \frac{\left(\frac{1}{3} x^3 - \frac{1}{20} x^5\right)_{-b}^b}{\left(\frac{1}{3} x^3\right)_{-b}^b} = \frac{\left(\frac{1}{3}(b^3 + b^3) - \frac{1}{20}(b^5 + b^5)\right)}{\left(\frac{1}{3}(b^3 + b^3)\right)} = \frac{\left(\frac{1}{3} - \frac{b^2}{20}\right)}{\left(\frac{1}{3}\right)} = 1 - \frac{3}{20} b^2 \quad \bar{y} = 1 - \frac{3}{20} b^2$$

Then  $(\bar{x}, \bar{y}) = \left(0, 1 - \frac{3}{20} b^2\right)$

If  $b = 2 \text{ cm} \rightarrow (\bar{x}, \bar{y}) = \left(0, 1 - \frac{3}{20}(4)\right) = \left(0, 1 - \frac{12}{20}\right) = \left(0, \frac{20-12}{20}\right) = \left(0, \frac{8}{20}\right) = \left(0, \frac{2}{5}\right)$ .

**Example 18: Determine the Centroid of the area shown in below Figure ?**

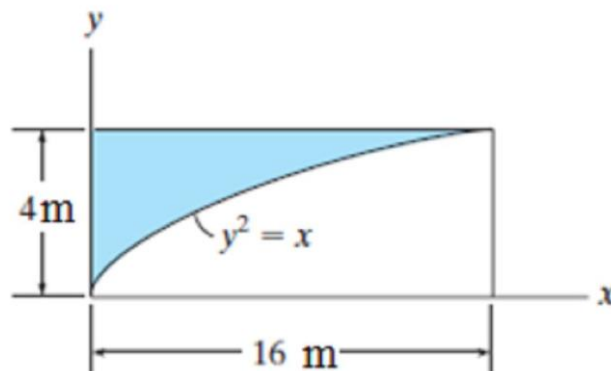

## Solution

We select a small strip as in below Figure

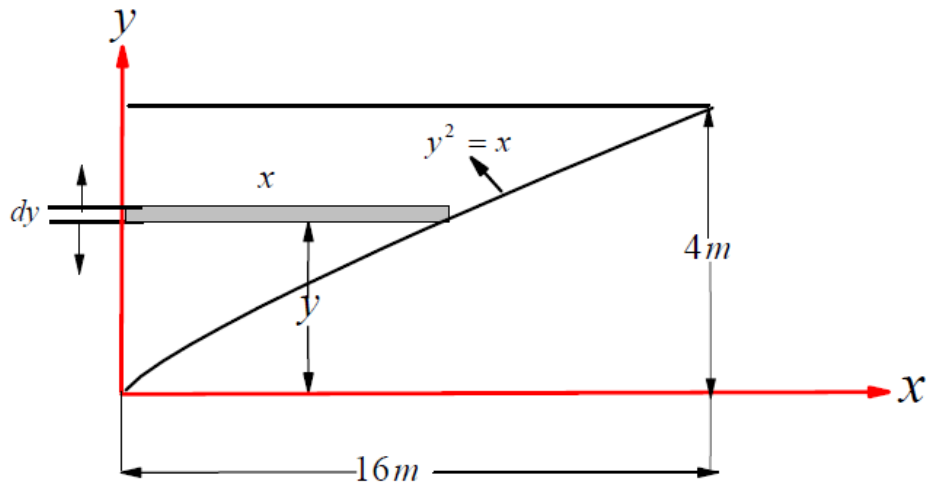

The centroid of area given by  $\bar{x} = \frac{\int \tilde{x} dA}{\int dA}$ ,  $\bar{y} = \frac{\int \tilde{y} dA}{\int dA}$

Where  $dA = x dy$ ,  $\tilde{x} = \frac{1}{2}x$ ,  $\tilde{y} = y$ ,  $x = y^2$ . Then

$$\bar{x} = \frac{\int \tilde{x} dA}{\int dA} = \frac{\int_0^y \left(\frac{1}{2}x\right) x dy}{\int_0^y x dy} = \frac{\frac{1}{2} \int_0^4 (y^2)y^2 dy}{\int_0^4 y^2 dy} = \frac{\frac{1}{2} \int_0^4 y^4 dy}{\int_0^4 y^2 dy} = \frac{\frac{1}{2} \frac{y^5}{5} \Big|_0^4}{\frac{y^3}{3} \Big|_0^4} = \frac{3}{10} \frac{4^5}{4^3}$$

$$\bar{x} = \frac{3}{10} \frac{16}{1} = \frac{24}{5} = 4.8\text{m}$$

$$\bar{y} = \frac{\int \tilde{y} dA}{\int dA} = \frac{\int_0^y y x dy}{\int_0^y x dy} = \frac{\int_0^4 y y^2 dy}{\int_0^4 y^2 dy} = \frac{\int_0^4 y^3 dy}{\int_0^4 y^2 dy} = \frac{\frac{y^4}{4} \Big|_0^4}{\frac{y^3}{3} \Big|_0^4} = \frac{3}{4} \frac{4^4}{4^3} = 3\text{m}$$

Then  $(\bar{x}, \bar{y}) = (4.8\text{m}, 3\text{m})$

## Chapter 6 Virtual Work

### Work by Force

If we consider  $\delta U = \text{work}$ ,  $F = \text{Force that done the work}$ ,  $dr = \text{displacement}$

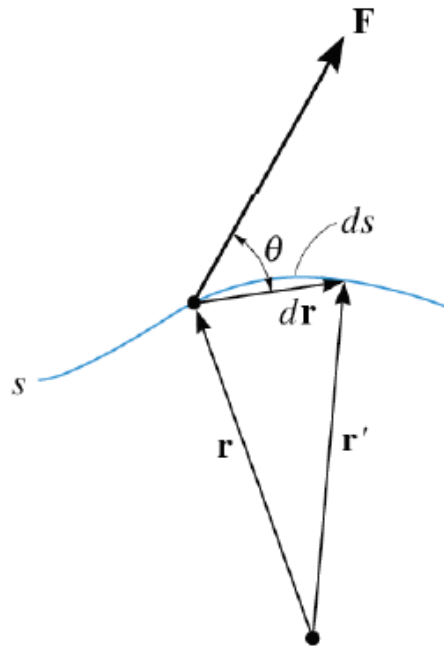

The work define by  $\delta U = F \cdot dr = Fdr \cos \theta$

### What is Virtual Work?

Virtual Work ( $\delta U = 0$ ) is imaginary work done when a particle subject to a number of forces is move a small imaginary distance( $du$ ).

### Virtual Work Utilization

#### Virtual Work

- 1- Utilize the principle of virtual work
- 2- To determine active forces that maintain the system in equilibrium,
- 3- To determine the equilibrium positions,
- 4-To relate the work done by conservative forces with potential energy.

**Example:1** The ladder has a weight  $W$  and rests against the floor and a smooth vertical wall. Using the principle of virtual work to determine the friction force acting on the ladder at the point of contact between the ladder and floor?

## Solution

Draw free body diagram as shown Apply the principle of virtual work, where

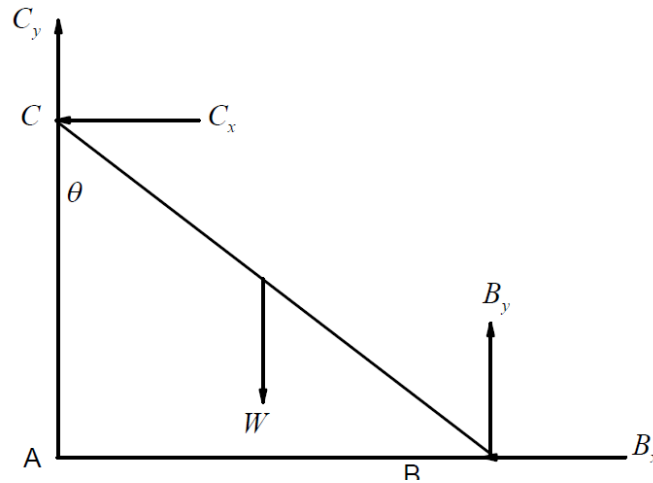

The normal forces  $B_y$  and  $C_x$  do no work because they are perpendicular to the displacement of point B and C. Thus  $B_y$  and  $C_x$  are not an active force.

The force  $W$  does work because the point  $D'$  moves up, so  $W$  is an active force. The force  $B_x$  does work as point B moves to the left, so  $B_x$  is an active force.

*The principle of virtual work says that the total work done by all forces acting on a system in static equilibrium is zero for any possible virtual displacement..  $\delta U = 0$*

$$W \delta y_D + B_x \delta x_A = 0 \quad (1)$$

From the Figure, we note that

$$y_C = L \cos \theta, \quad y_D = y_C - \frac{L}{2} \cos \theta = \frac{L}{2} \cos \theta, \quad x_A = L \sin \theta \quad (2)$$

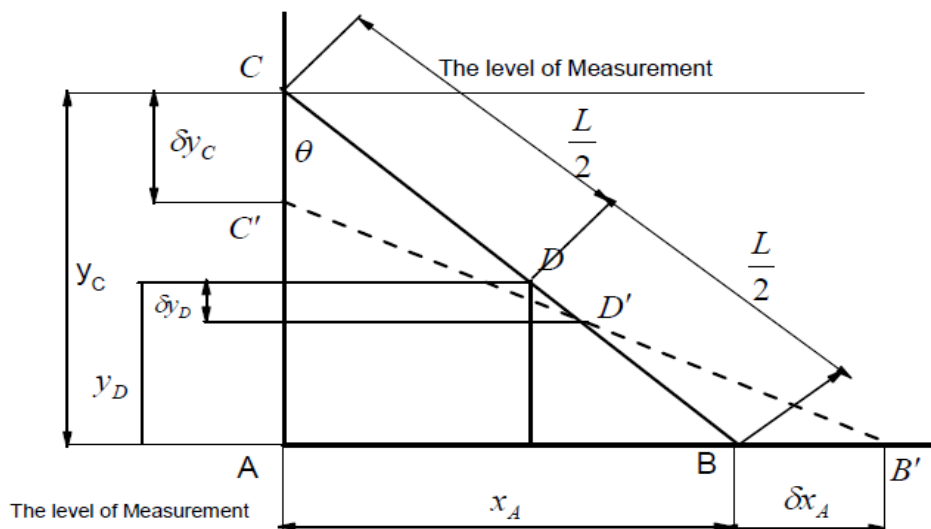

From Figs. (1) and (2)

$$W \delta \left( \frac{L}{2} \cos \theta \right) + B_x \delta (L \sin \theta) = 0$$

$$-\frac{W}{2} \sin \theta \delta \theta + B_x \cos \theta \delta \theta = 0 \quad \rightarrow \quad \left\{ -\frac{W}{2} \sin \theta + B_x \cos \theta \right\} \delta \theta = 0$$

$$\delta\theta \neq 0. \text{ Then } B_x = \frac{W}{2} \frac{\sin\theta}{\cos\theta} \quad \rightarrow \quad B_x = \frac{W}{2} \tan\theta.$$

**Example:2** Use the principle of virtual work to determine the force  $P$  required to keep the two rods in equilibrium when the angle  $= 30^\circ$  and weight  $W = 30\text{ lb}$ . The rods are each of length  $L$  and of negligible weight.

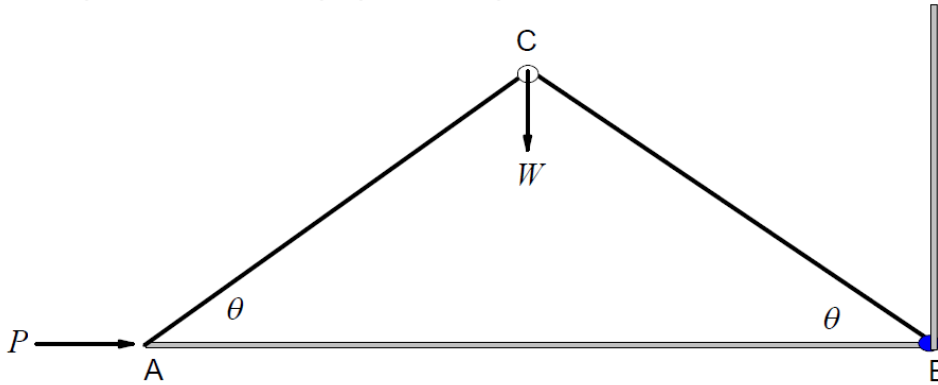

### Solution

Draw free body diagram as shown

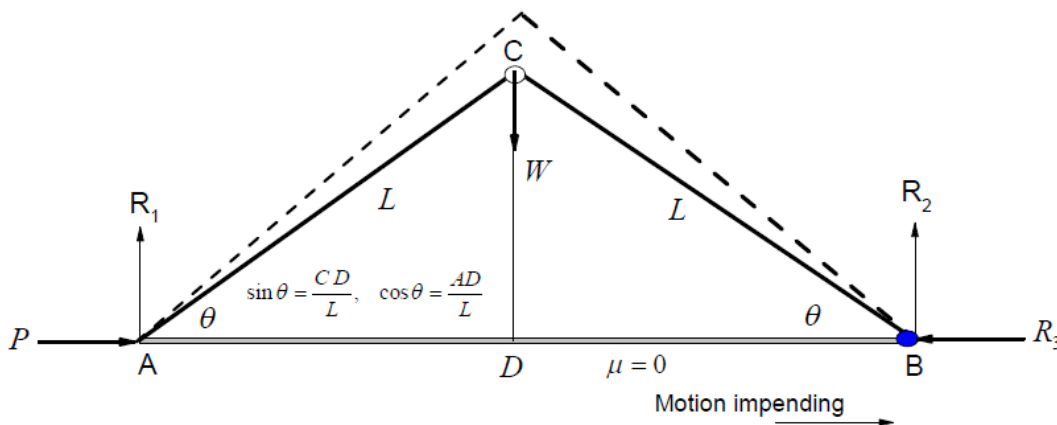

Apply the principle of virtual work, where

The normal force  $R_1$  does no work because it is perpendicular to the displacement of point A. Thus  $R_1$  is not an active force.

The forces  $R_2$  and  $R_3$  do no work because the point B does not move. Thus  $R_2$  and  $R_3$  are not an active force.

The force  $W$  does work because the point C moves up, so  $W$  is an active force.

*The principle of virtual work says that the total work done by all forces acting on a system in static equilibrium is zero for any possible virtual displacement..  $\delta U = 0$*

$$W \delta(DC) + P \delta(AB) = 0 \quad (1)$$

From the Figure as shown

$$AB = 2L \cos\theta, \quad DC = L \sin\theta, \quad (2)$$

From Eqs. (1) and (2)

$$W \delta(L \sin\theta) + P \delta(2L \cos\theta) = 0$$

$$W \cos\theta \delta\theta - 2P \sin\theta \delta\theta = 0 \quad \rightarrow \quad \left\{ W \cos\theta - 2P \sin\theta \right\} \delta\theta = 0$$

$$W \cos\theta - 2P \sin\theta = 0, \quad \delta\theta \neq 0,$$

$$P = \frac{W}{2} \frac{\cos\theta}{\sin\theta} \quad \rightarrow \quad P = \frac{W}{2} \cot\theta$$

$$\text{Then, } P = \frac{W}{2} \cot 30^\circ = \frac{50}{2} (1.732) \quad \rightarrow \quad P = 43.3 \text{ lb.}$$

**Example:3** Use the principle of virtual work to determine the value of the weight  $W$  required to maintain the mechanism in the position shown, if  $P = 50 \text{ N}$ .

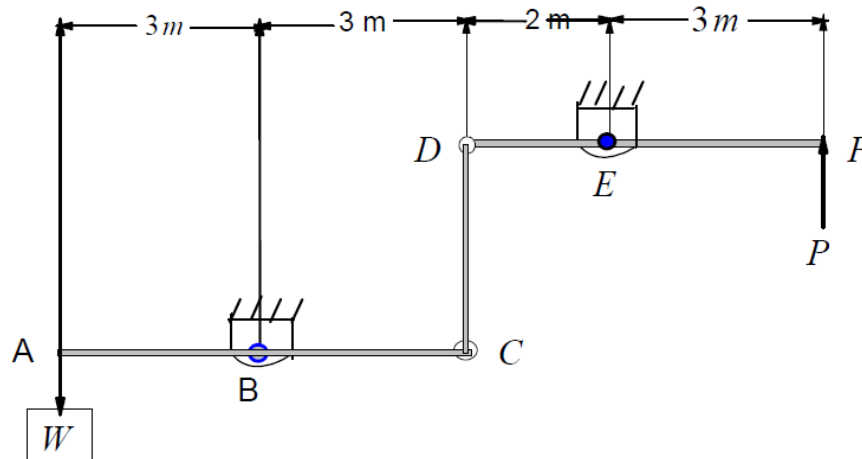

### Solution

Draw free body diagram as shown

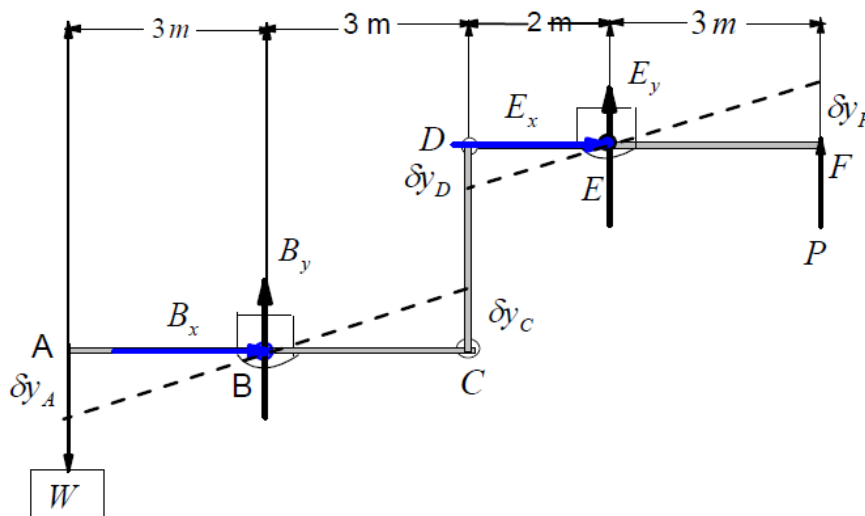

Apply the principle of virtual work, where

The force  $W$  does work if  $A$  moves vertically, so  $W$  is an active force.

The reaction forces at  $B$  and  $E$  do no work because  $B$  and  $E$  do not move; thus the reactions are not active forces.

The force  $P$  does work as point  $F$  moves vertically, so  $P$  is an active force.

*The principle of virtual work says that the total work done by all forces acting on a system in static equilibrium is zero for any possible virtual displacement.  $\delta U = 0$*

$$-W \delta y_A + P \delta y_F = 0 \quad (1) \text{ From the}$$

Figure as shown

$$\tan \alpha = \frac{\delta y_A}{3} = \frac{\delta y_C}{3} \quad \rightarrow \quad \delta y_A = \delta y_C \quad (2)$$

$$\tan \beta = \frac{\delta y_D}{2} = \frac{\delta y_F}{3} \quad \rightarrow \quad \delta y_D = \frac{2}{3} \delta y_F \quad (3)$$

Also,

$$\delta y_C = \delta y_D \quad (4)$$

From Eqs. (2) -(4)

$$\delta y_A = \frac{2}{3} \delta y_F \quad (5)$$

Substitution from Eq. (5) into Eq. (1), we get

$$-W \left( \frac{2}{3} \delta y_F \right) + P \delta y_F = 0 \quad \rightarrow \quad \left( -\frac{2}{3} W + P \right) \delta y_F = 0$$

$$-\frac{2}{3} W + P = 0, \quad \delta y_F \neq 0,$$

$$-\frac{2}{3} W + P = 0 \quad \rightarrow \quad W = \frac{3}{2} P = \frac{3}{2} (50).$$

Then  $W = 75 \text{ N}$

## Examples

**Example:1** Rotating the threaded rod  $AC$  of the automobile jack causes joints  $A$  and  $C$  to move closer together, thus raising the weight  $W$ . Determine the axial force in the rod, if  $\theta = 30^\circ$  and  $W = 2 \text{ kN}$ .

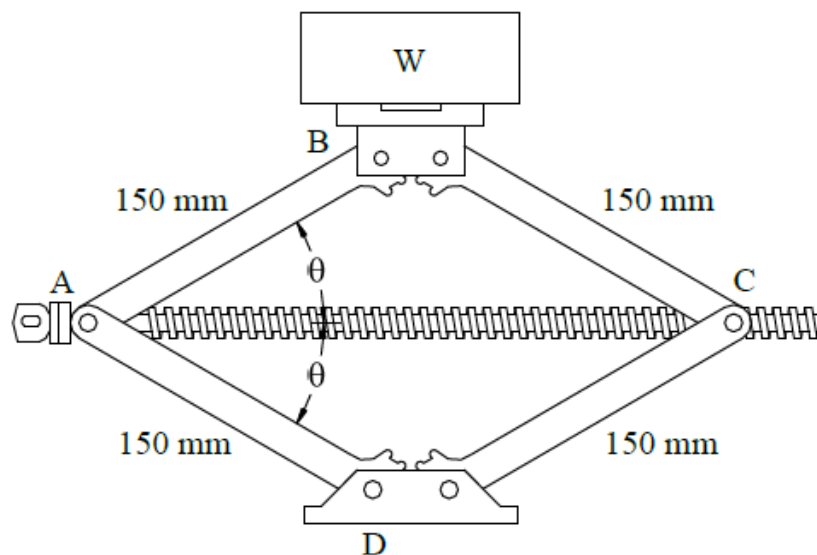

### Solution

Draw free body diagram as shown

The effect of the rod is then represented by the two forces  $F_r$ . One can see that,  $W$  and the two  $F_r$  forces are the active forces.



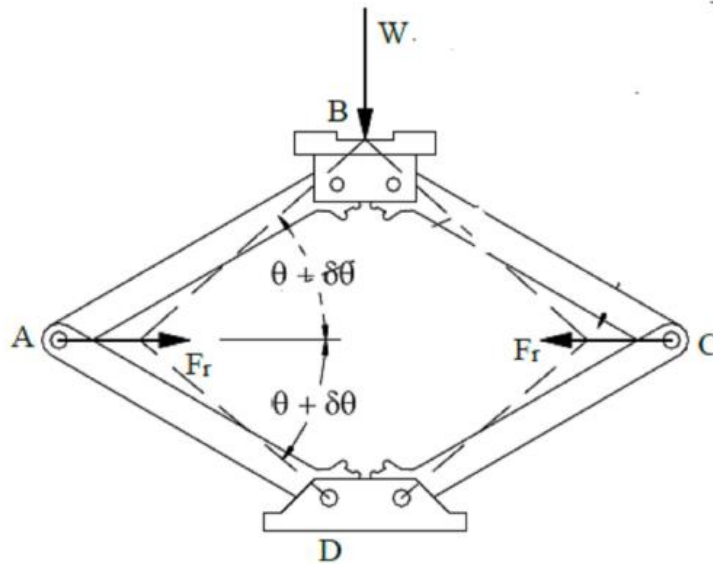

Introduce coordinates measured from fixed points to the points of application of the active forces

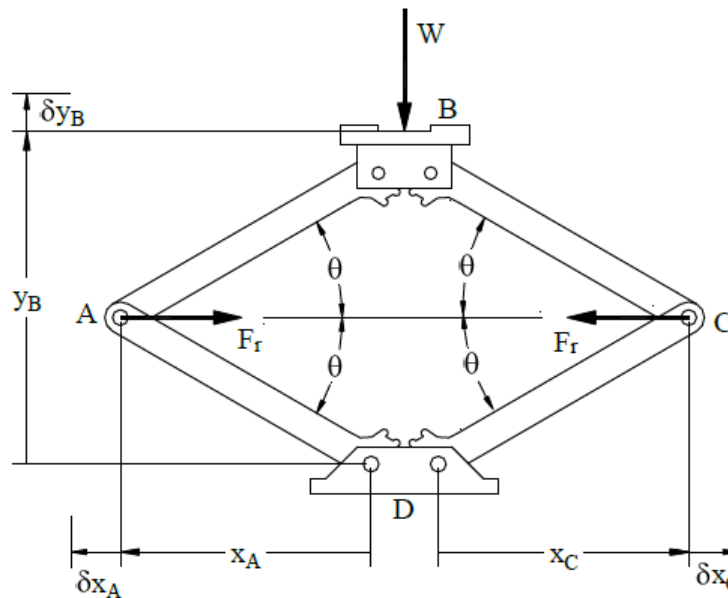

*The principle of virtual work says that the total work done by all forces acting on a system in static equilibrium is zero for any possible virtual displacement.  $\delta U = 0$*

$$-W \delta y_B - F_r \delta y_A - F_r \delta y_C = 0 \quad (1)$$

From the Figure as shown

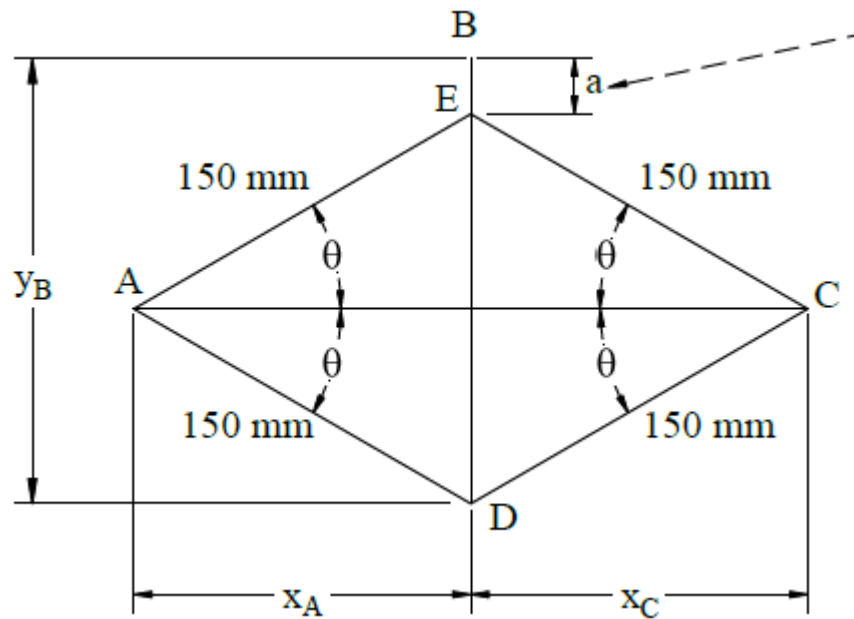

$$x_A = x_C = 150 \cos \theta, \quad y_B = DE + EB = 2(150 \sin \theta) + a \quad (2)$$

$$-W \delta(2(150 \sin \theta) + a) - F_r \delta(150 \cos \theta) - F_r \delta(150 \cos \theta) = 0$$

$$-W(300 \cos \theta) \delta \theta + F_r(150 \sin \theta) \delta \theta + F_r(150 \sin \theta) \delta \theta = 0$$

$$\left\{ -W(300 \cos \theta) + F_r(300 \sin \theta) \right\} \delta \theta = 0$$

$$F_r = W \frac{\cos \theta}{\sin \theta} = W \cot \theta = W \cot 30^\circ = 2(1.732) = 3.464. \quad \text{Then } F_r = 3.464 \text{ KN}$$

**Example2:** Determine the vertical reaction at support C, if  $P = 2 \text{ KN}$

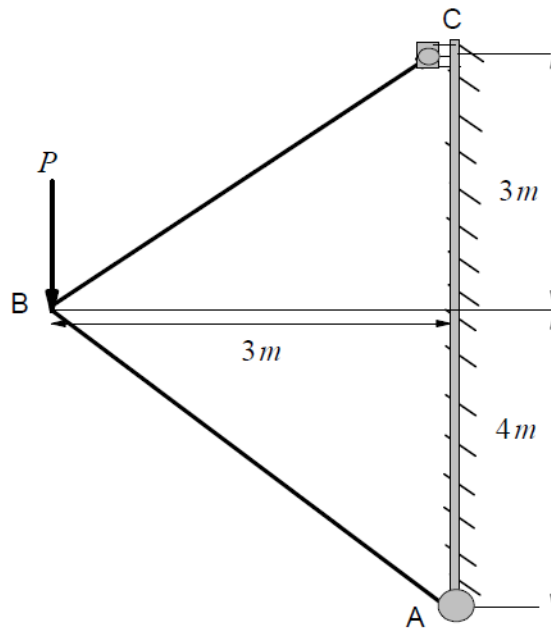

## Solution

Draw free body diagram as shown

One can see that,  $C_y$  and  $P$  are the active forces  $C_y$  and  $P$  are active forces for the displacements

The normal force  $C_x$  does no work because it is perpendicular to the displacement of point  $C$ . Thus  $C_x$  is not an active force.

The forces  $A_x$  and  $A_y$  do no work because the point  $A$  does not move. Thus  $A_x$  and  $A_y$  are not an active force.

The force  $P$  does work because the point  $B$  moves up, so  $B$  is an active force.

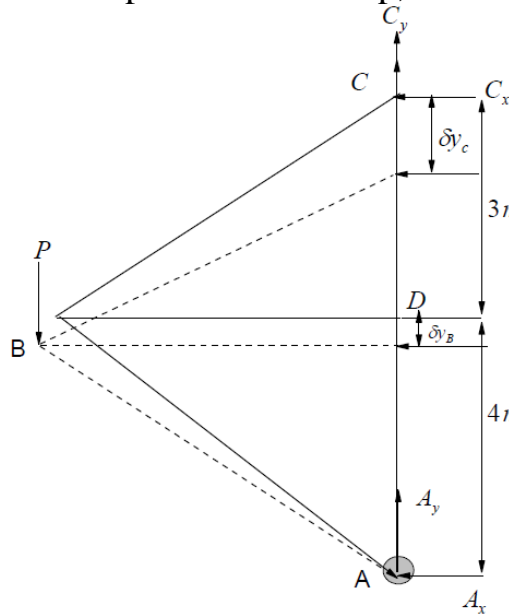

*The principle of virtual work says that the total work done by all forces acting on a system in static equilibrium is zero for any possible virtual displacement..  $\delta U = 0$*

$$-P \delta y_B + C_y \delta y_C = 0 \quad (1)$$

From the Figure as shown, we find that

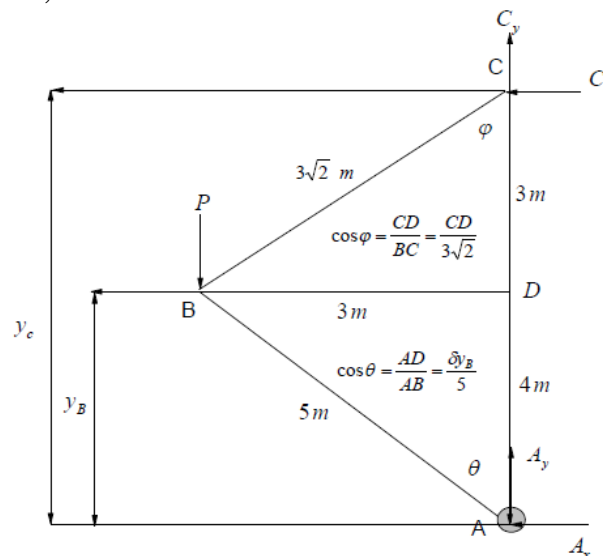

$$y_B = 5 \cos \theta \rightarrow \delta y_B = -5 \sin \theta d\theta \quad (2)$$

$$y_C = y_B + CD = 5 \cos \theta + 3\sqrt{2} \cos \phi \rightarrow \delta y_C = -5 \sin \theta d\theta - 3\sqrt{2} \sin \phi d\phi \quad (3)$$

From Eqs. (1)-(3)

$$-P(-5 \sin \theta d\theta) + C_y(-5 \sin \theta d\theta) - 3\sqrt{2} \sin \phi d\phi = 0 \quad (4)$$

Again, From the third Figure we find that,

$$\sin \theta = \frac{BD}{5}, \quad \sin \phi = \frac{BD}{3\sqrt{2}} \rightarrow 5 \sin \theta = 3\sqrt{2} \sin \phi$$

$$5 \cos \theta d\theta = 3\sqrt{2} \cos \phi d\phi \rightarrow d\theta = \frac{3\sqrt{2}}{5} \frac{\cos \phi}{\cos \theta} d\phi \quad (5)$$

From Eq. (5) into Eq. (4), we get

$$-P(-5 \sin \theta) \left( \frac{3\sqrt{2}}{5} \frac{\cos \phi}{\cos \theta} d\phi \right) + C_y \left[ (-5 \sin \theta) \left( \frac{3\sqrt{2}}{5} \frac{\cos \phi}{\cos \theta} d\phi \right) - 3\sqrt{2} \sin \phi d\phi \right] = 0$$

$$\left\{ P \tan \theta - C_y \left( \tan \theta + \tan \phi \right) \right\} d\phi = 0 \rightarrow P \tan \theta - C_y \left( \tan \theta + \tan \phi \right) = 0$$

$$C_y = P \frac{\tan \theta}{\tan \theta + \tan \phi} = (2) \frac{\frac{3}{4}}{\frac{3}{4} + 1} = (2) \frac{3}{7} = \frac{6}{7} = 0.857 \text{ KN}$$

Then  $C_y = 0.857 \text{ KN}$

**Example:3** Two symmetric rods  $AB$  and  $BC$  are smoothly joined at  $B$  and placed in a vertical plane such that  $A$  and  $C$  touch a smooth horizontal plane. If the group is kept in equilibrium by an elastic string joining the points of the two rods. Using the principle of virtual work, find the tension in the string and show that the coefficient of elasticity in the string is  $\frac{4}{5}W$  if the equilibrium takes place when the inclination of the two rods on the horizontal is  $\cos^{-1} \frac{3}{5}$ .

**Solution**

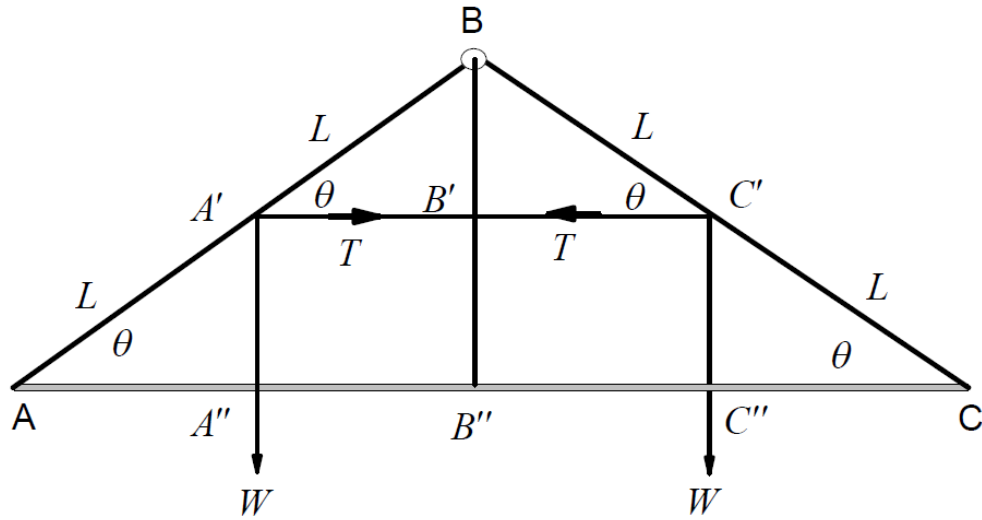

The principle of virtual work says that the total work done by all forces acting on a system in static equilibrium is zero for any possible virtual displacement..  $\delta U = 0$

$$W \delta(A'A'') + W \delta(C'C'') + T \delta(B'C') + T \delta(A'B') = 0 \quad (1)$$

Form the Figure, we note that

$$A'A'' = C'C'' = L \sin \theta, \quad B'C' = A'B' = L \cos \theta \quad (2)$$

From Figs. (1) and (2)

$$2W \delta(L \sin \theta) + 2T \delta(L \cos \theta) = 0$$

$$W \cos \theta \delta \theta - T \sin \theta \delta \theta = 0 \quad \rightarrow \quad \left\{ W \cos \theta - T \sin \theta \right\} \delta \theta = 0$$

$$W \cos \theta - T \sin \theta = 0, \quad \delta \theta \neq 0,$$

$$\text{Then } T = W \frac{\cos \theta}{\sin \theta} \quad \rightarrow \quad T = \frac{3}{5} \frac{5}{4} W \quad \rightarrow \quad T = \frac{3}{4} W .$$

From Hawke's law we note that

$$T = \frac{L - L_0}{L_0} \lambda = \frac{2L \cos \theta - \frac{3}{4} L}{\frac{3}{4} L} \lambda = \frac{2L(\frac{3}{5}) - \frac{3}{4} L}{\frac{3}{4} L} \lambda = \left(\frac{8}{5} - 1\right) \lambda = \frac{3}{4} W \quad \rightarrow \quad \left(\frac{3}{5}\right) \lambda = \frac{3}{4} W$$

$$\lambda = \frac{5}{4} W$$

## Exercises

**Exercise1:** A ladder of mass  $m$  has its ends on a smooth wall and floor. The foot of the ladder is tied by an inextensible rope of negligible mass to the base of the wall so the ladder makes an angle  $\alpha$  with the floor. Using the principle of virtual work, find the magnitude of the tension in the rope?

**Exercise2:** Determine the force exerted by the vice on the block when a given force  $p$  is applied at  $C$  . Assume that there is no friction

